

Instruction Manual

10" Compound Slide Miter Saw

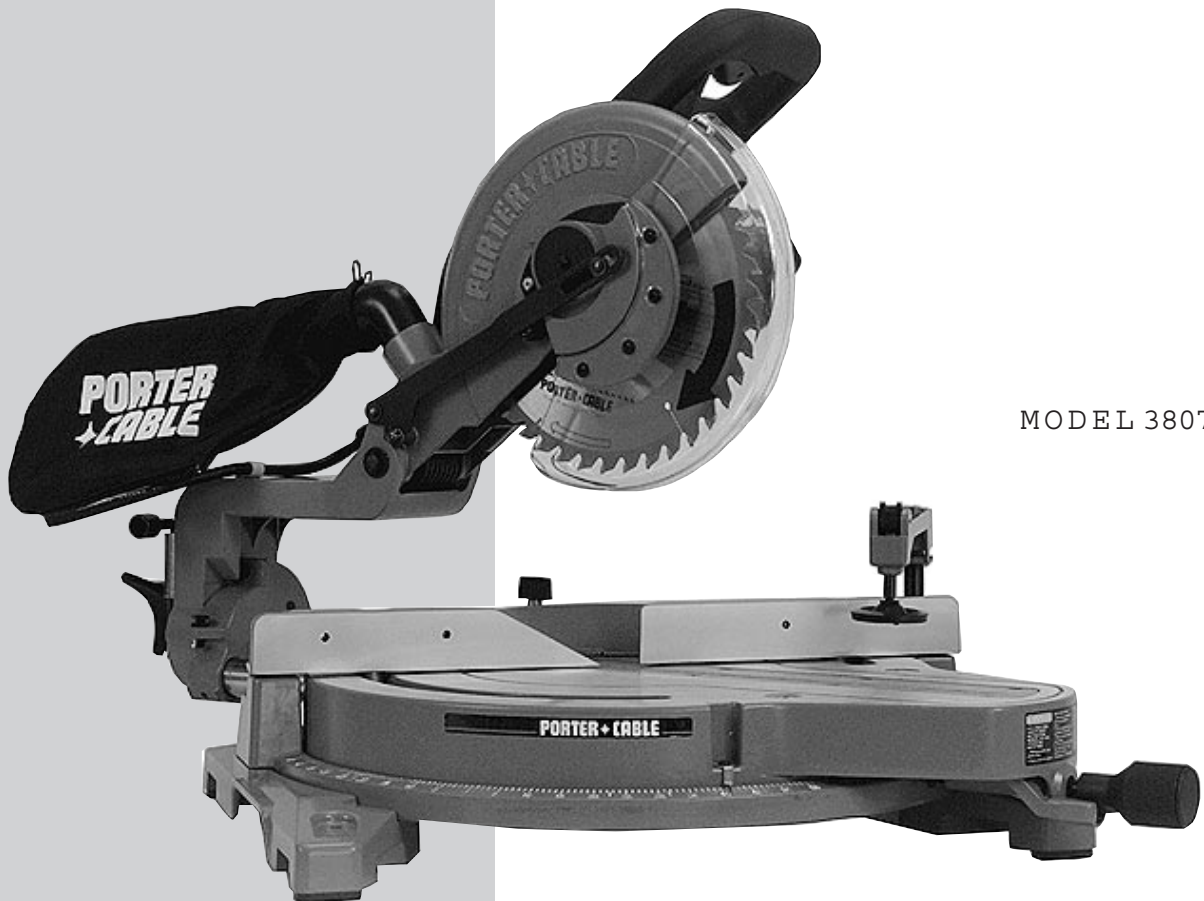

MODEL 3807

To learn more about Porter-Cable
visit our website at:

<http://www.porter-cable.com>

PORTER-CABLE
PROFESSIONAL POWER TOOLS

IMPORTANT

Please make certain that the person who is to use this equipment carefully reads and understands these instructions before starting operations.

The Model and Serial No. plate is located on the main housing of the tool. Record these numbers in the spaces below and retain for future reference.

Model No. _____

Type _____

Serial No. _____

Part No. 897462-001

IMPORTANT SAFETY INSTRUCTIONS

WARNING: When using electric tools, basic safety precautions should always be followed to reduce the risk of fire, electric shock and personal injury, including the following:

READ AND FOLLOW ALL INSTRUCTIONS.

There are certain applications for which this tool was designed. Porter-Cable strongly recommends that this tool NOT be modified and/or used for any application other than for which it was designed. If you have any questions relative to its application DO NOT use the tool until you have written Porter-Cable and we have advised you.

Technical Service Manager
Porter-Cable Corporation
4825 Highway 45 North, P. O. Box 2468
Jackson, TN 38302-2468

POLARIZED PLUGS: To reduce the risk of electric shock, this equipment has a polarized plug (one blade is wider than the other). This plug will fit in a polarized outlet only one way. If the plug does not fit fully in the outlet, reverse the plug. If it still does not fit, contact a qualified electrician to install the proper outlet. Do not change the plug in any way.

1. **KEEP WORK AREA CLEAN.** Cluttered areas and benches invite injuries.
2. **AVOID DANGEROUS ENVIRONMENT.** Don't expose power tools to rain. Don't use power tools in damp or wet locations. Keep area well lit. Avoid chemical or corrosive environment. Do not use tool in presence of flammable liquids or gases.
3. **KEEP CHILDREN AWAY.** Do not let visitors contact tool or extension cord. All visitors should be kept away from work area.
4. **STORE IDLE TOOLS.** When not in use, tools should be stored in dry, and high or locked-up place out of reach of children.
5. **DON'T FORCE TOOL.** It will do the job better and safer at the rate for which it was intended.
6. **USE RIGHT TOOL.** Do not force tool or attachment to do a job for which it was not designed.
7. **DRESS PROPERLY.** Do not wear loose clothing or jewelry. Loose clothing, draw strings and jewelry can be caught in moving parts. Rubber gloves and non-skid footwear are recommended when working outdoors. Wear protective hair covering to contain long hair.
8. **USE SAFETY GLASSES.** Wear safety glasses or goggles while operating power tools. Also face or dust mask if operation creates dust. All persons in the area where power tools are being operated should also wear safety glasses and face or dust mask. Refer to ANSI Z87.1 standard for appropriate recommendations.
9. **SECURE WORK.** Use clamps or a vise to hold work. It's safer than using your hand and it frees both hands to operate tool.
10. **DON'T OVERREACH.** Keep proper footing and balance at all times.
11. **MAINTAIN TOOLS WITH CARE.** Keep tools sharp and clean for better and safer performance. Follow instructions for lubricating and changing accessories. Inspect tool cords periodically and if damaged, have repaired by authorized service facility. Inspect extension cords periodically and replace if damaged. Have all worn, broken or lost parts replaced immediately. Keep handles dry, clean and free from oil and grease.
12. **DISCONNECT TOOLS** when not in use, before servicing, and when changing accessories such as blades, bits, cutters, etc.
13. **REMOVE ADJUSTING KEYS AND WRENCHES.** Form habit of checking to see that keys and adjusting wrenches are removed from the tool before turning it on.
14. **AVOID UNINTENTIONAL STARTING.** Do not carry a plugged-in tool with finger on switch. Be sure switch is off when plugging in. Keep hands, body and clothing clear of blades, bits, cutters, etc. when plugging in the tool.
15. **OUTDOOR USE EXTENSION CORDS.** When tool is used outdoors, use only extension cords marked Suitable for use with outdoor appliances store indoors when not in use.
16. **STAY ALERT.** Watch what you are doing. Use common sense. Do not operate tool when you are tired or while under the influence of medication, alcohol or drugs.
17. **CHECK DAMAGED PARTS.** Before further use of the tool, a guard or other part that is damaged should be carefully checked to determine that it will operate properly and perform its intended function. Check for alignment of moving parts, binding of moving parts, breakage of parts, mounting, and any other conditions that may affect its operation. A guard or other part that is damaged should be properly repaired or replaced by an authorized service center unless otherwise indicated elsewhere in this instruction manual. Have defective switches replaced by authorized service center. Do not use tool if switch does not turn it on and off.
18. **KEEP GUARDS IN PLACE AND IN WORKING ORDER.** Never wedge or tie lower guard open. Check operation of lower guard before each use. Do not use if lower guard does not close briskly over saw blade.

CAUTION: If saw is dropped, lower guard may be bent, restricting full return.

19. **KEEP BLADES CLEAN AND SHARP.** Sharp blades minimize stalling and kickback.

20. DANGER: KEEP HANDS AWAY FROM CUTTING AREA. Keep hands away from blades. Do not reach underneath work while blade is rotating. Do not attempt to remove cut material when blade is moving.

CAUTION: Blades coast after being turned off

21. MAKE WORKSHOP CHILDPROOF with padlocks, master switches, or by removing starter keys.
22. USE RECOMMENDED ACCESSORIES. The use of accessories and attachments not recommended by Porter-Cable may cause hazards or risk of injury to persons.
23. NEVER STAND ON TOOL. Serious injury could occur if the tool is tipped or if the cutting tool is accidentally contacted.
24. DIRECTION OF FEED. Feed work into a blade or cutter against the direction of rotation of the blade or cutter only.
25. NEVER LEAVE TOOL RUNNING UNATTENDED. TURN POWER OFF. Don't leave tool until it comes to a complete stop.
26. ALWAYS HOLD THE WORK FIRMLY against the fence and table. DO NOT perform any operation freehand.
27. WARNING: ALWAYS keep hands out of path of saw blade. If the workpiece you are cutting would cause your hand to be inside the table hazard area (see section TABLE HAZARD AREA), the workpiece should be clamped in place before making cut.
28. NEVER use blades larger or smaller in diameter than recommended. Recommended size of blade is 10" in diameter.
29. NEVER use blades recommended for operation at less than 6000 RPM.
30. USE the blade guard at all times.
31. NEVER reach around or behind saw blade.
32. TURN OFF SAW and MAKE SURE blade has come to a complete stop before removing or securing workpiece, changing workpiece angle or changing the angle of the blade.
33. USE PROPER EXTENSION CORD. Make sure your extension is in good condition. When using an extension cord, be sure to use one heavy enough to carry the current your product will draw. An undersized cord will cause a drop in line voltage resulting in loss of power and overheating. The table in EXTENSION CORD SELECTION shows the correct size to use depending on cord length and nameplate ampere rating of the tool. If in doubt, use the next heavier gage. The smaller the gage number, the heavier the cord.

SAVE THESE INSTRUCTIONS

ADDITIONAL SAFETY RULES FOR COMPOUND SLIDE MITER SAWS

1. WARNING: USE ONLY CROSS-CUTTING SAW BLADES. WHEN USING CARBIDE TIPPED BLADES BE SURE THE HOOK ANGLE IS 5 DEGREES OR LESS. DO NOT USE BLADES WITH DEEP GULLETS AS THEY CAN DEFLECT AND CONTACT GUARD.
2. WARNING: Do not operate the miter saw until it is completely assembled and installed according to the instructions.
3. IF YOU ARE NOT thoroughly familiar with the operation of compound slide miter saws, obtain advice from your supervisor, instructor or other qualified person.
4. BE SURE blade is sharp, runs freely and is free of vibration.
5. ALLOW the motor to come up to full speed before starting cut.
6. KEEP motor air slots clean and free of chips
7. ALWAYS MAKE SURE rotating table is tight before cutting, even if the table is positioned in one of the positive stops
8. BE SURE blade and flanges are clean and that arbor screw is tightened securely.
9. USE ONLY blade flanges specified for your saw.
10. NEVER apply lubricants to the blade when it is running.
11. ALWAYS CHECK the blade for cracks or damage before operation. Replace cracked or damaged blade immediately.
12. ALWAYS KEEP the lower blade guard in place and operating properly.
13. MAKE SURE blade is not contacting workpiece before switch is turned on.
14. NEVER LOCK the switch in the ON position.
15. IMPORTANT: After completing cut, release power switch and wait for coasting blade to stop before returning saw to raised position.
16. DO NOT remove jammed or cut-off pieces until blade has stopped.
17. NEVER cut ferrous metals or masonry.

18. NEVER recut small pieces.
19. PROVIDE ADEQUATE SUPPORT to the sides of the saw table for long workpieces.
20. NEVER use the miter saw in an area with flammable liquids or gases.
21. NEVER USE SOLVENTS TO CLEAN PLASTIC PARTS. Solvents could possibly dissolve or otherwise damage the material. Only a soft, damp cloth should be used to clean plastic parts
22. DISCONNECT SAW from power source and clean the machine before leaving it.
23. MAKE SURE the work area is cleaned before leaving the machine.
24. ADDITIONAL INFORMATION regarding the safe and proper operation of this product is available from the National Safety Council, 1121 Spring Lake Drive, Itasca, IL 60143-3201, in the Accident Prevention Manual for Industrial Operation and also in the Safety Data Sheets provided by the NSC. Please also refer to the American National Standard Institute ANSI 01.1 Safety Requirements for the Woodworking Machinery and the U.S. Department of Labor OSHA 1910.213 Regulations.
25. SOME WOOD CONTAINS PRESERVATIVES WHICH CAN BE TOXIC. Take extra care to prevent inhalation and skin contact when working with these materials. Request, and follow, any safety information available from your material supplier.
26. DON'T ABUSE CORD. Never carry tool by cord or yank it to disconnect from receptacle. Keep cord from heat, oil, and sharp edges. Have damaged or worn power cord and strain reliever replaced immediately. DO NOT ATTEMPT TO REPAIR POWER CORD.
27. WEAR EAR PROTECTION to safeguard against possible hearing loss.
28. AVOID CUTTING NAILS AND KNOTS. Inspect for and remove all nails from lumber before cutting. Try to do layout cuts between knots
29. NEVER USE LIQUID COOLANT. To do so could present electrical shock hazard.
30. KEEP CLEAR OF SAWDUST EJECTION CHUTE. Sawdust and chips are expelled out the ejection chute at rear of saw. Do not allow anyone in this area while saw is in operation.
31. WARNING: Slide cutting by PULLING the saw towards the operator can be dangerous, causing the saw to kick upwards and towards the operator. Always PUSH the saw forward, away from the operator, and towards the fence when slide cutting.
32. WHEN USING THE SAW AS A MITER AND MAKING CHOP CUTS, MAKE SURE the saw sliding mechanism is locked in place to prevent the saw from kicking towards the operator.
33. WHEN THE MITER SAW IS NOT IN USE, the switch should be locked in the OFF position to prevent unauthorized use of the saw.

REPLACEMENT PARTS

When servicing use only identical replacement parts

MOTOR

Many Porter-Cable tools will operate on either D.C., or single phase 25 to 60 cycle A.C. current and voltage within plus or minus 5 percent of that shown on the specification plate of the tool. Several models, however, are designed for A.C. current only. Refer to the specification plate on your tool for proper voltage and current rating.

CAUTION: Do not operate your tool on a current on which the voltage is not within correct limits. Do not operate tools rated A.C. only on D.C. current. To do so may seriously damage the tool.

EXTENSION CORD SELECTION

If an extension cord is used, make sure the conductor size is large enough to prevent excessive voltage drop which will cause loss of power and possible motor damage. A table of recommended extension cord sizes will be found in this section. This table is based on limiting line voltage drop to 5 volts (10 volts for 230 volts) at 150% of rated amperes.

If an extension cord is to be used outdoors it must be marked with the suffix W-A following the cord type designation. For example SJTW-A to indicate it is acceptable for outdoor use.

RECOMMENDED EXTENSION CORD SIZES FOR USE WITH PORTABLE ELECTRIC TOOLS

		Length of Cord in Feet									
		115V 230V	25 Ft. 50 Ft.	50 Ft. 100 Ft.	100 Ft. 200 Ft.	150 Ft. 300 Ft.	200 Ft. 400 Ft.	250 Ft. 500 Ft.	300 Ft. 600 Ft.	400 Ft. 800 Ft.	500 Ft. 1000 Ft.
Nameplate Ampere Rating	0-2		18	18	18	16	16	14	14	12	12
	2-3		18	18	16	14	14	12	12	10	10
	3-4		18	18	16	14	12	12	10	10	8
	4-5		18	18	14	12	12	10	10	8	8
	5-6		18	16	14	12	10	10	8	8	6
	6-8		18	16	12	10	10	8	6	6	6
	8-10		18	14	12	10	8	8	6	6	4
	10-12		16	14	10	8	8	6	6	4	4
	12-14		16	12	10	8	6	6	6	4	2
	14-16		16	12	10	8	6	6	4	4	2
	16-18		14	12	8	8	6	4	4	2	2
18-20		14	12	8	6	6	4	4	2	2	

OPERATING INSTRUCTIONS

FOREWORD

Porter-Cable Model 3807 is a high capacity 10" compound miter saw designed to cut wood and non-ferrous metals. It can crosscut $11\frac{1}{2} \times 3\frac{3}{16}$ " and $9 \times 3\frac{7}{8}$ ", miter at 45 both left and right $8\frac{1}{8} \times 3\frac{3}{16}$ ", and $6\frac{3}{8} \times 3\frac{7}{8}$ ", bevel at 45 left $11\frac{1}{2} \times 2\frac{3}{16}$ " and $8\frac{1}{2} \times 2\frac{5}{8}$ ", compound 45 left miter and 45 bevel $8\frac{1}{8} \times 2\frac{3}{16}$ " and $6\frac{1}{2} \times 2\frac{5}{8}$ " and compound 45 right miter and bevel $8\frac{1}{8} \times 1\frac{7}{8}$ " and $3\frac{1}{2} \times 2\frac{5}{8}$ "

POWER CONNECTIONS

A separate electrical circuit should be used for your tools. If an extension cord is used, make sure the conductor size is large enough to prevent excessive voltage drop which will cause loss of power and possible motor damage. For distances up to 100 feet use #12 wire. For distances up to 150 feet use #10 wire. If an extension cord is to be used outdoors it must be marked with the suffix W-A following the cord type designation. For example SJTW-A to indicate it is acceptable for outdoor use. Replace damaged or worn cord immediately. Before connecting the motor to the power line, make sure the switch is in the OFF position and be sure that the electric current is of the same characteristics as stamped on motor nameplate.

CAUTION: Keep the extension cord away from the cutting area and position the cord so that it will not be a tripping hazard or contact material being placed into or removed from the machine.

UNPACKING

1. Carefully remove the machine from the carton. We recommend you retain all packing materials until after you have inspected and satisfactorily operated the machine.

WARNING: Do not connect the machine to the power source until you have read and understood this entire instruction manual.

2. Place the machine on a firm, level surface where there is plenty of room for handling and properly supporting the workpiece.

3. Familiarize yourself with all features and controls as explained in this manual.

4. The machine is shipped with the cuttinghead locked in the down position and the table rotated to the 45 degree right miter position, Fig. 2. To release the head and move it to the operating position see

MOVING CUTTINGHEAD TO THE UP POSITION and MOVING THE TABLE TO THE 90 DEGREE CUT-OFF POSITION in this section.

5. Unassembled items are shown in Fig. 3 for identification and use in assembling the saw.

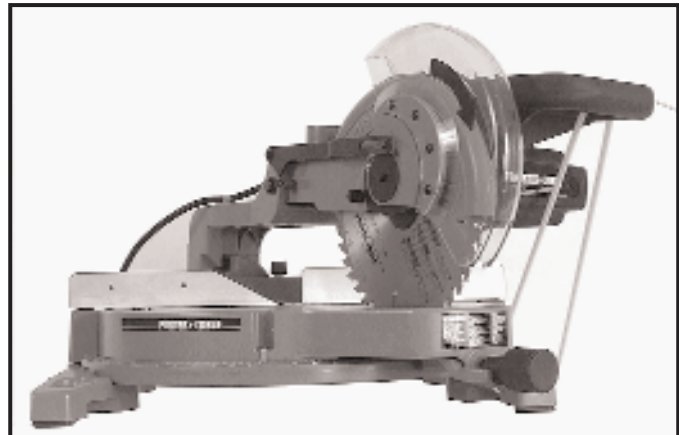

Fig. 2

MOVING CUTTINGHEAD TO THE UP POSITION and MOVING THE TABLE TO THE 90 DEGREE CUT-OFF POSITION in this section.

5. Unassembled items are shown in Fig. 3 for identification and use in assembling the saw.

- 1 Dust Elbow
- 2 Work Clamp
- 3 Dust Bag
- 4 Open End Wrench

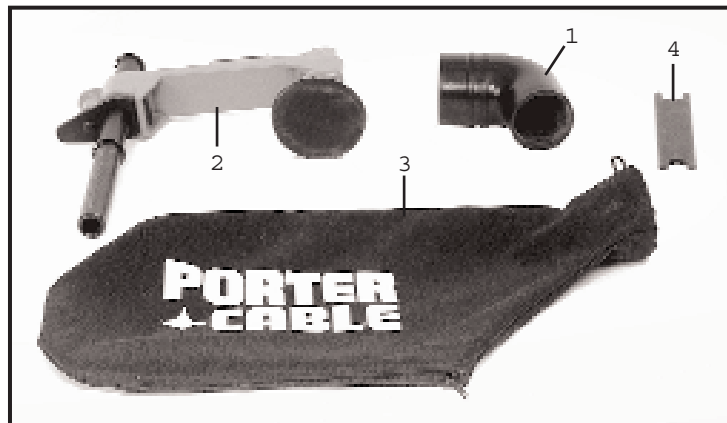

Fig. 3

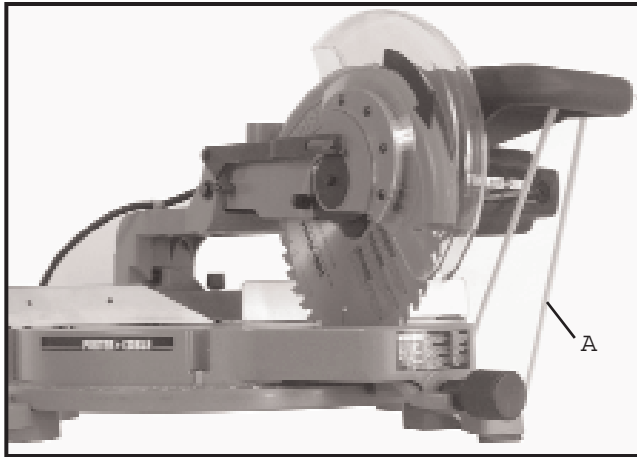

Fig. 4

MOVING CUTTINGHEAD TO THE REAR POSITION

1. MAKE CERTAIN THE MACHINE IS DISCONNECTED FROM THE POWER SOURCE.
2. Carefully remove cable tie (A) Fig. 4, which is holding the cuttinghead in the down position.
3. To move the cuttinghead (D) Fig. 5, to the rear position, loosen lock knob (E) and push cuttinghead (D) to the rear position. Then tighten lock knob (E) Fig. 6.
4. Fig. 6, illustrates the cuttinghead locked in the rear position.

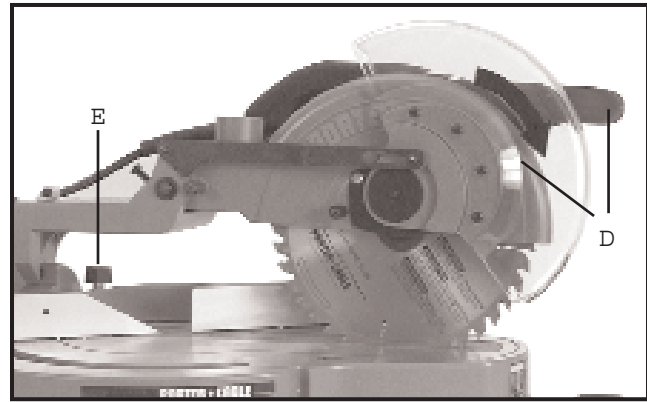

Fig. 5

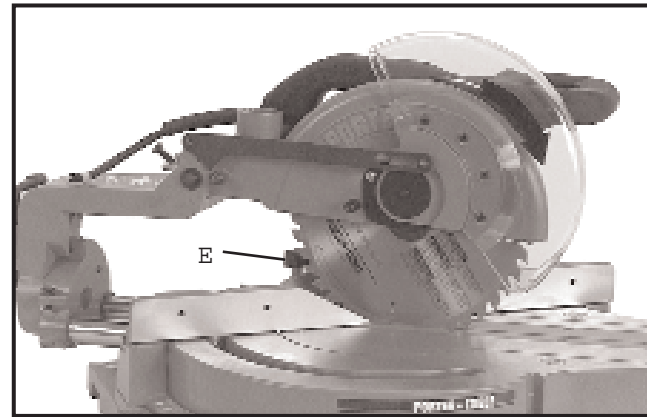

Fig. 6

RAISING THE CUTTINGHEAD

1. While holding the cuttinghead (A) Fig. 7, down, pull out and rotate cuttinghead lock knob (B) 90 degrees until pin (C) Fig. 8, is in the horizontal position as shown. The cuttinghead can then be raised.
2. Fig. 9 illustrates the cuttinghead (A) in the raised position.
3. **WARNING:** Cutterhead lock knob (B) Fig. 7, is designed to lock the cutterhead in the down position for only storage or carrying. Never operate saw with the cutterhead in the lock down position.

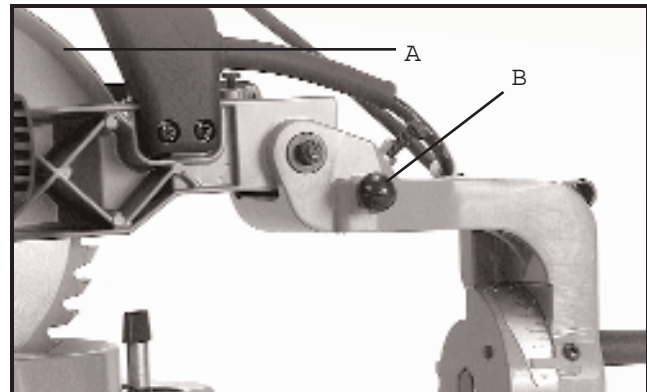

Fig. 7

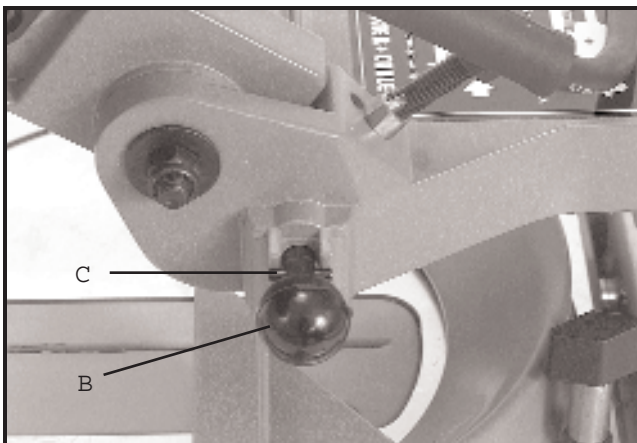

Fig. 8

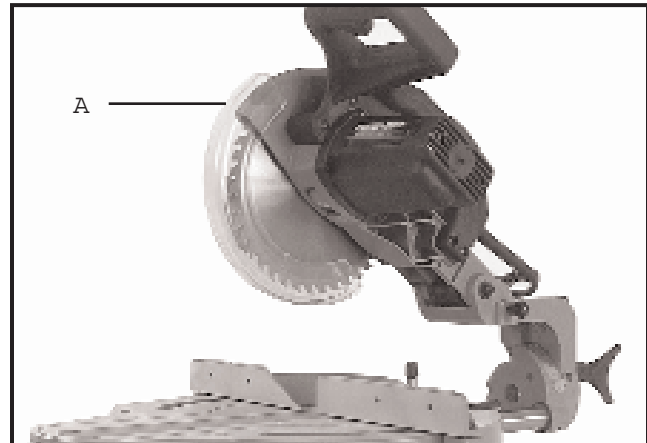

Fig. 9

ASSEMBLY

WARNING: FOR YOUR OWN SAFETY, DO NOT CONNECT THE MITER SAW TO THE POWER SOURCE UNTIL THE MACHINE IS COMPLETELY ASSEMBLED AND YOU HAVE READ AND UNDERSTOOD THE ENTIRE OWNER S MANUAL.

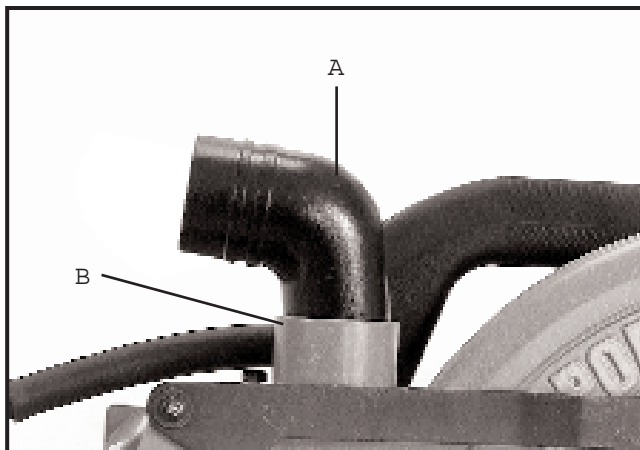

Fig. 10

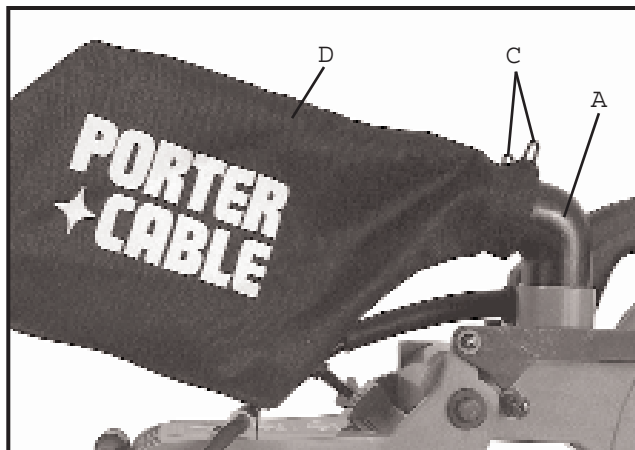

Fig. 11

ASSEMBLING DUST ELBOW AND DUST BAG

1. Insert smooth end of dust elbow (A) Fig. 10, into opening (B). The dust elbow (A) can be rotated as desired.
2. Compress spring clips (C) Fig. 11, on dust bag (D) and clip dust bag onto end of elbow (A) as shown.

MOVING TABLE TO THE 0 DEGREE CUT-OFF POSITION

1. Rotate locking knob (A) Fig. 12, counterclockwise to unlock. Depress lever (B) and rotate table (C) to the 0 degree straight out-off position, release lever (B) and tighten locking knob (A).
2. Fig. 13, illustrates the table (C) in the 0 degree straight out-off position.
3. For proper operation and adjustment of the table, refer to sections, ROTATING TABLE FOR MITER CUTTING, ADJUSTING CLAMPING ACTION OF TABLE LOCKING MECHANISM and ADJUSTING SLIDING FIT BETWEEN MOVABLE TABLE AND BASE.

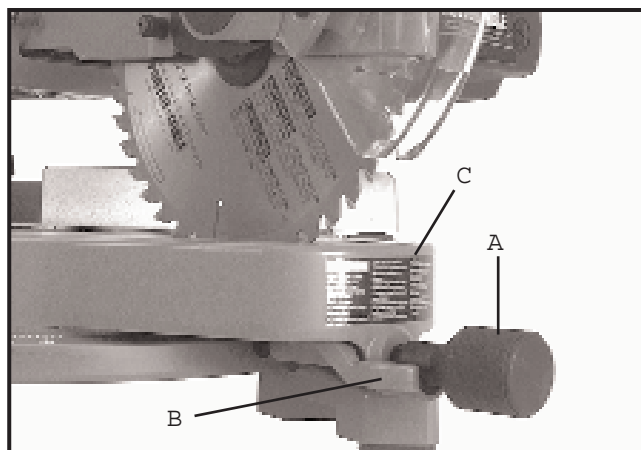

Fig. 12

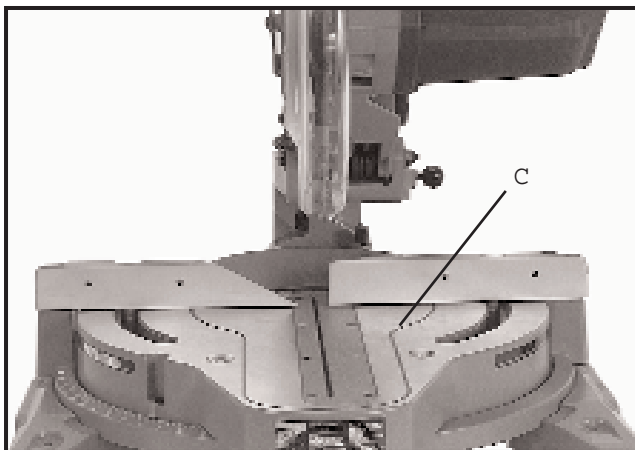

Fig. 13

ASSEMBLING WORK CLAMP

1. Insert post (A) Fig. 14, of work clamp assembly (B) down through hole in the base of the machine as shown and lock in place by tightening lock knob (C). The work clamp (B) Fig. 14, can be used on the right or left side of the cutting head.

2. For proper operation of the work clamp, refer to section WORK CLAMP OPERATION.

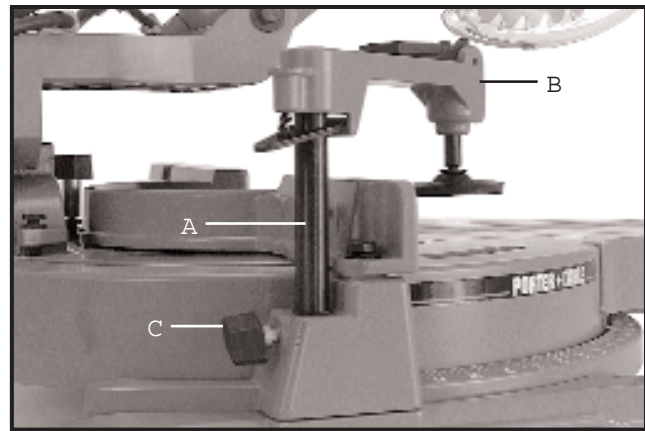

Fig. 14

STARTING AND STOPPING MACHINE

To start the machine, depress switch trigger (A) Fig. 15. To stop the machine, release the switch trigger.

This saw is equipped with an automatic electric blade brake. As soon as the switch trigger (A) Fig. 15, is released, the electric brake is activated and stops the blade in seconds.

DANGER: A TURNING SAW BLADE CAN BE DANGEROUS. AFTER COMPLETING CUT, RELEASE SWITCH TRIGGER (A) FIG. 15, TO ACTIVATE BLADE BRAKE. KEEP CUTTING-HEAD DOWN UNTIL BLADE HAS COME TO A COMPLETE STOP.

WARNING: THE TORQUE DEVELOPED DURING BRAKING MAY LOOSEN THE ARBOR SCREW. THE ARBOR SCREW SHOULD BE CHECKED PERIODICALLY AND TIGHTENED IF NECESSARY.

LOCKING SWITCH IN THE OFF POSITION

IMPORTANT: When the miter saw is not in use, the switch should be locked in the OFF position using a padlock (B) Fig. 16, with a $\frac{3}{16}$ " diameter shackle to prevent unauthorized use of the saw.

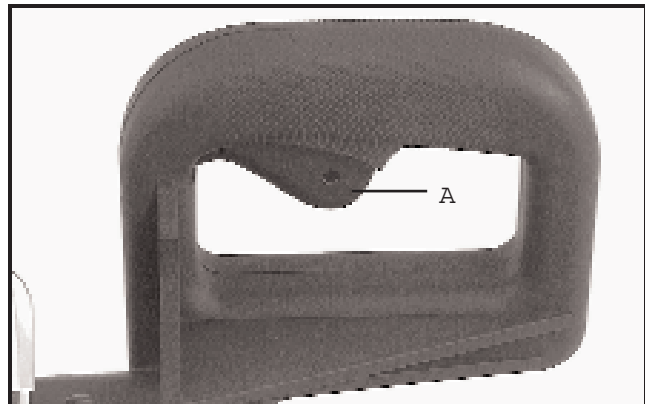

Fig. 15

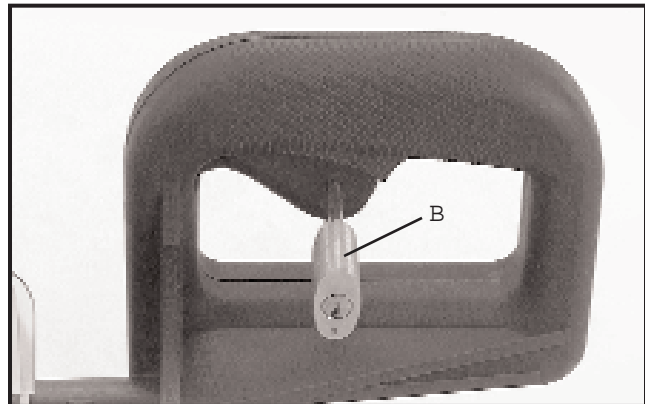

Fig. 16

ROTATING TABLE FOR MITER CUTTING

1. Your compound slide saw will cut any angle from a straight 0 degree cut to 57 degrees right and 47 degrees left. Rotate locking knob (A) Fig. 17, counterclockwise, depress lock lever (B), and move table to desired position.

2. The compound miter saw is equipped with positive stops at the 0 degree cut-off position and at the 15, 22.5, 31.62, and 45 degrees left and right positions.

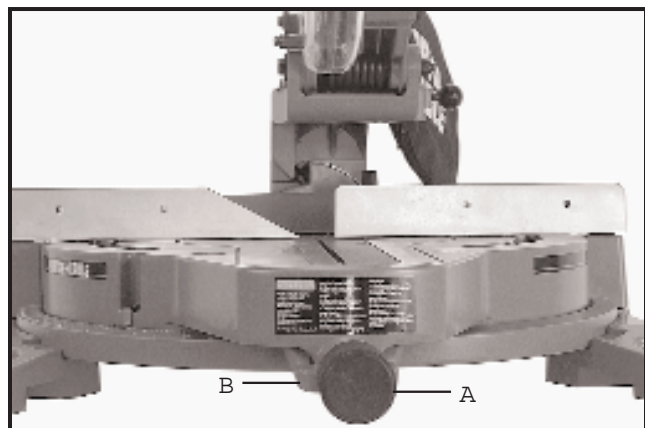

Fig. 17

ADJUSTING SLIDING FIT BETWEEN MOVABLE TABLE AND BASE

CAUTION: DISCONNECT THE MACHINE FROM THE POWER SOURCE.

If it ever becomes necessary to adjust the sliding fit between the movable table and the base, turn nut (A) Fig. 18, clockwise to increase or counterclockwise to decrease the sliding fit. This adjustment should not be too tight that it restricts the rotating movement of the table or too loose that it affects the accuracy of the saw.

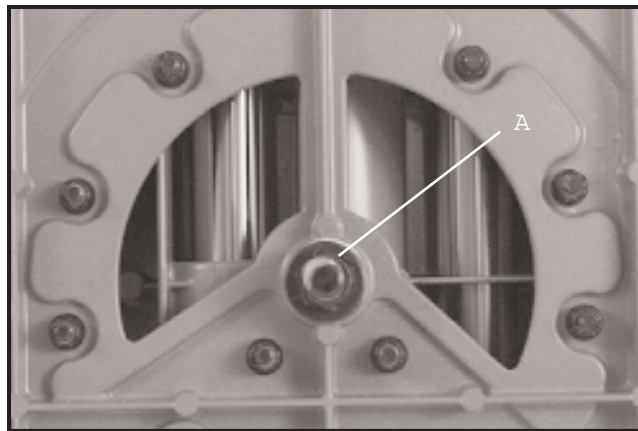

Fig. 18

ADJUSTING FENCE 90 DEGREES TO BLADE

CAUTION: DISCONNECT THE MACHINE FROM THE POWER SOURCE.

IMPORTANT: BEFORE MAKING THIS ADJUSTMENT MAKE CERTAIN THE BLADE IS SET AT 0 DEGREES TO THE TABLE. SEE SECTION ADJUSTING 0 AND 45 DEGREE BEVEL POSITIVE STOPS.

1. DISCONNECT THE SAW FROM THE POWER SOURCE.

2. Rotate the movable table so that the blade is 90 degrees to the fence and the positive stop for the 0 degree mark on the scale is engaged.

3. Using a square (A) Fig. 19, place one end of the square against the front of the fence (B) and the other end against the blade (C), with the blade in the down position, as shown. Check to see if the fence is 90 degrees to the blade.

4. If an adjustment is necessary, the fence (B) Fig. 19, can be adjusted by loosening the two screws, shown at (D), that attach the fence to the base, using wrench supplied. Adjust the fence (B) as required and tighten the two screws (D).

5. After you are sure the fence is 90 degrees to the blade, adjust the cursor (F) Fig. 20, so the pointer is aligned with the 0 degree mark on the scale by loosening screw (G), adjusting cursor (F) and tightening screw (G).

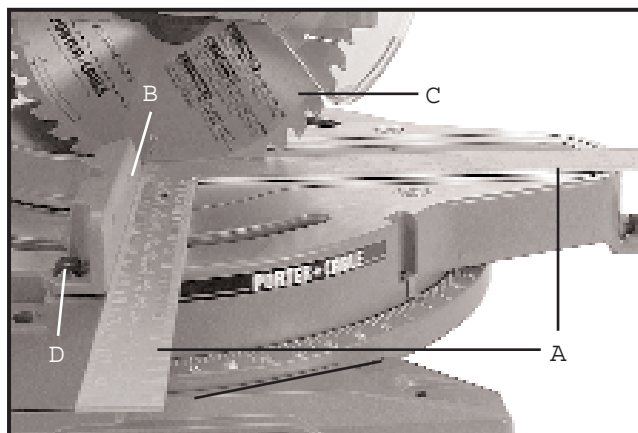

Fig. 19

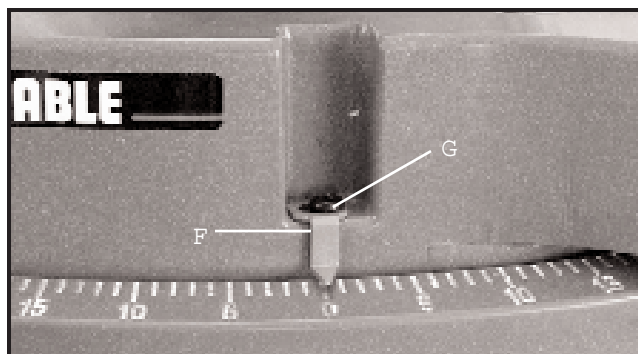

Fig. 20

TABLE HAZARD AREA

WARNING: THE AREA INSIDE THE TWO RED LINES (A) FIG. 21, ON THE TABLE IS DESIGNATED AS A HAZARD ZONE. NEVER PLACE YOUR HANDS INSIDE THIS AREA WHILE THE TOOL IS BEING OPERATED.

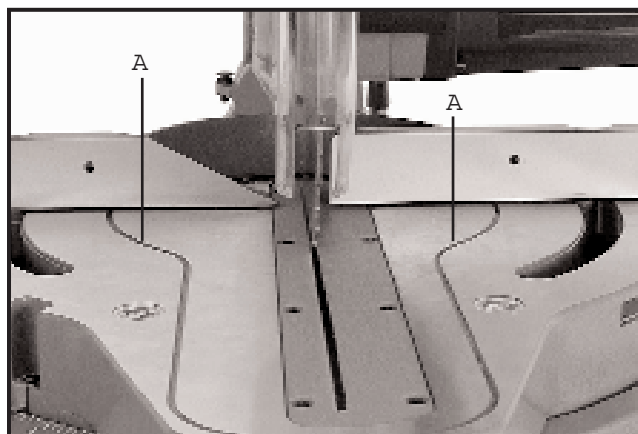

Fig. 21

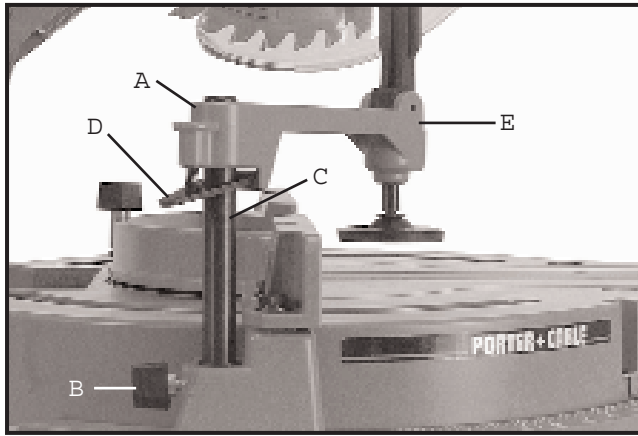

Fig. 22

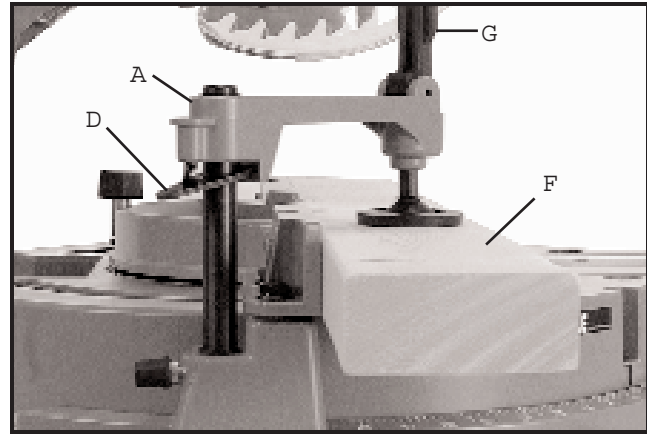

Fig. 23

WORK CLAMP OPERATION

1. The height of the work clamp (A) Fig. 22, can be adjusted by loosening lock knob (B) and moving post (C) up or down, or depressing lock lever (D) and sliding clamp body (E) up or down. After height of clamp (A) is adjusted, tighten lock knob (B) and/or release lock lever (D).

2. During operation, lower clamp (A) Fig. 23, by depressing lock lever (D), until the bottom of the clamp (A) lightly contacts top of workpiece (F). **IMPORTANT:** When lowering clamp (A) make certain cam lever (G) is in the up position as shown.

3. For final clamping of the workpiece (F) Fig. 24, against the table, lower cam lever (G) as shown. After cut is completed, lift lever (G). This will raise clamp (A) slightly, allowing you to slide or remove workpiece (F).

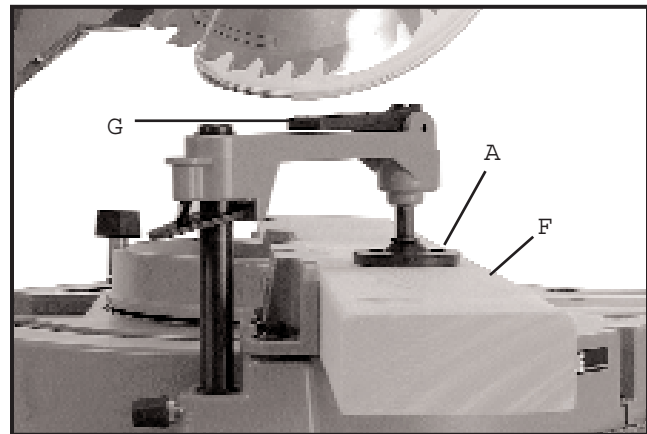

Fig. 24

TILTING CUTTINGHEAD FOR BEVEL CUTTING

CAUTION: DISCONNECT THE MACHINE FROM THE POWER SOURCE.

1. The cuttinghead of your compound miter saw can be tilted to cut any bevel angle from a 90 degree straight cut-off to a 45 degree left bevel angle by loosening bevel lock handle (A) Fig. 25, tilting cuttinghead (B) to the desired angle, and tightening lock handle (A).

2. Positive stops are provided to rapidly position the saw blade at 90 and 45 degrees to the table. Refer to the section of this manual titled Adjusting 90 and 45 degree bevel positive stops. The bevel angle of the cutting arm is determined by the position of the pointer (C) Fig. 26, on scale (D).

3. In addition, an indicator (E) Fig. 26, is provided on the bevel scale at the 33.9 degree bevel angle for cutting crown moulding. Refer to the CUTTING CROWN MOULDING section of this manual.

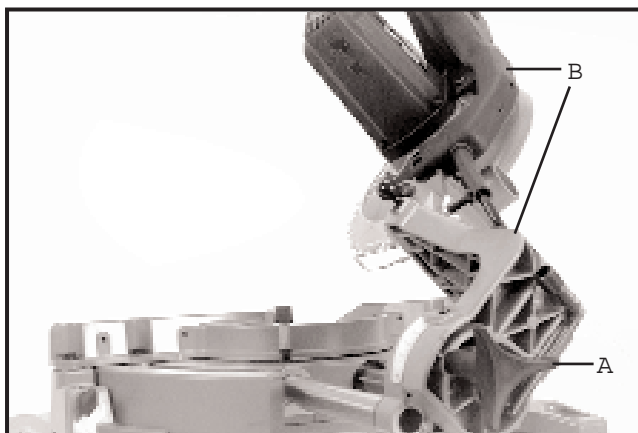

Fig. 25

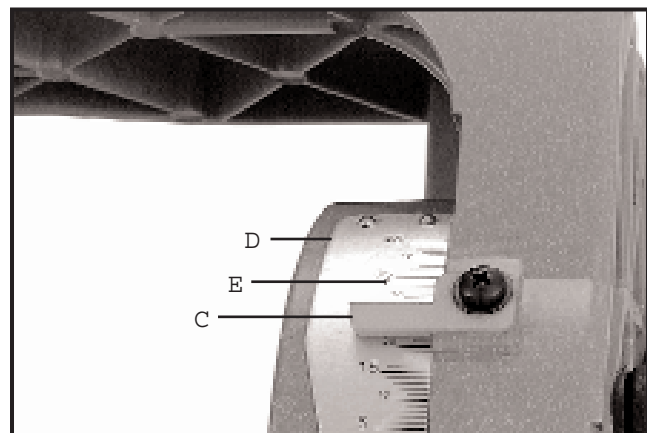

Fig. 26

ADJUSTING SLIDING FIT BETWEEN TRUNNION AND BEVEL BRACKET

After a long period of time it may become necessary to adjust the sliding fit between the trunnion (A) Fig. 27, and the bevel bracket (B) by tightening adjusting nut (C). NOTE: This adjustment must be made with the bevel lock handle (D) loose. Correct adjustment is when a good snug sliding fit is obtained between these two parts. This adjustment should not be too tight that it restricts the sliding movement or too loose that it affects the accuracy of the saw cut.

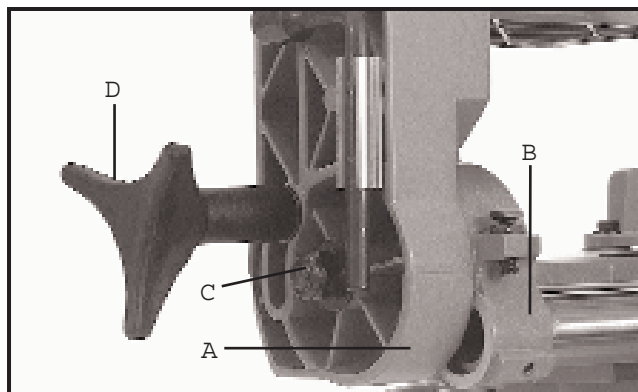

Fig. 27

ADJUSTING 90 AND 45 DEGREE BEVEL POSITIVE STOPS

1. DISCONNECT THE SAW FROM THE POWER SOURCE.

2. Loosen bevel lock handle and move the cuttinghead all the way to the right. Then tighten bevel lock handle.

3. Using a square (A) Fig. 28, place one end of the square on the table and the other end against the blade, as shown. Check to see if the blade is at 90 degrees to the table.

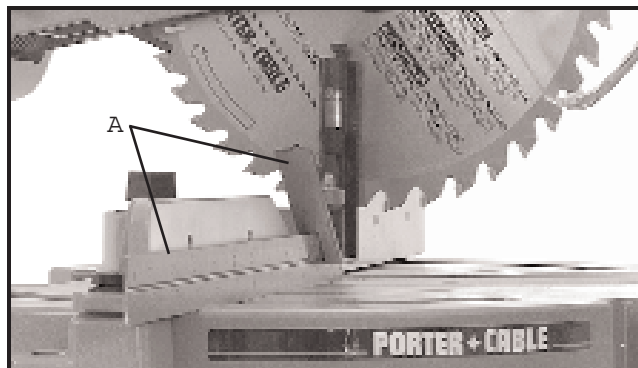

Fig. 28

4. If an adjustment is necessary, loosen bevel lock handle. Then loosen locknut (B) Fig. 29, and turn adjusting screw (C) until head of screw (C) contacts inside of casting (D) when blade is 90 degrees to the table. Then tighten locknut (B).

5. When you are certain blade is 90 degrees to table, loosen screw (J) Fig. 30, and adjust pointer (H) to line up with the 0 degree mark on bevel scale (K).

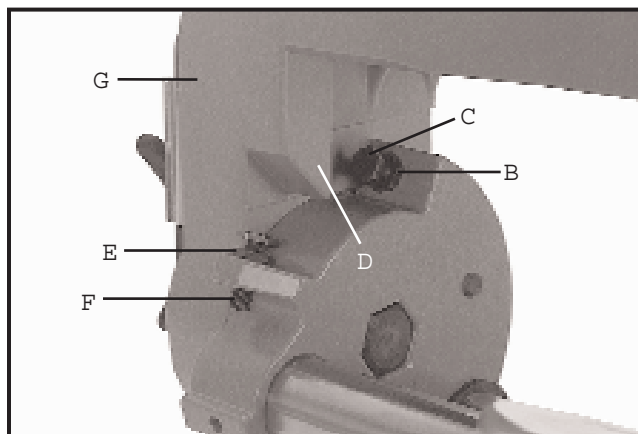

Fig. 29

6. Loosen bevel lock handle and move cuttinghead all the way to the left bevel position and tighten bevel lock handle.

7. Using a square (A) Fig. 31, check to see if the blade is at 45 degrees to the table, as shown.

8. If an adjustment is necessary, loosen bevel lock handle. Then loosen locknut (E) Fig. 29, and turn adjusting screw (F) until head of screw (F) contacts surface (G) when blade is 45 degrees to the table. Then tighten locknut (E).

9. These positive stops enable you to rapidly position the blade at the most common bevel angles to the table, 90 and 45 degrees.

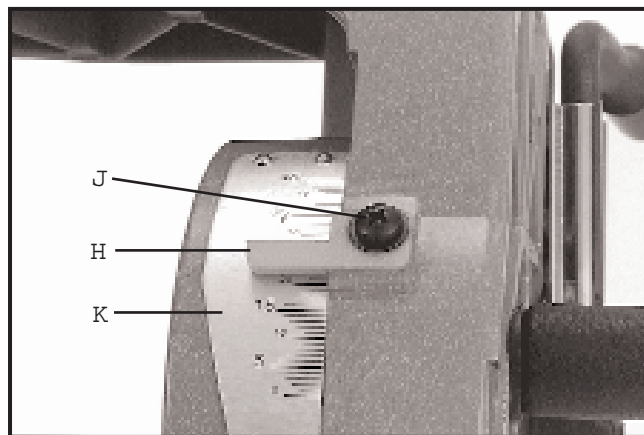

Fig. 30

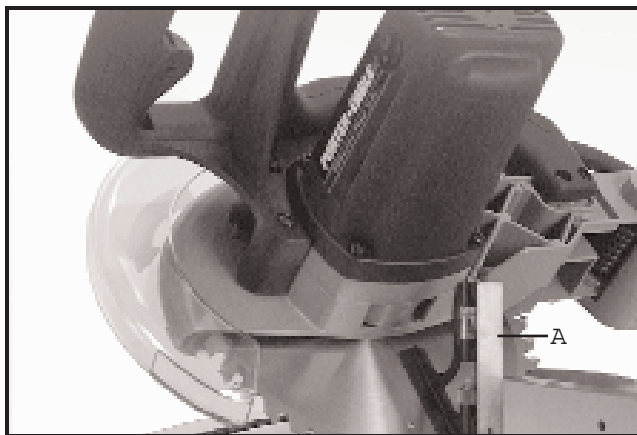

Fig. 31

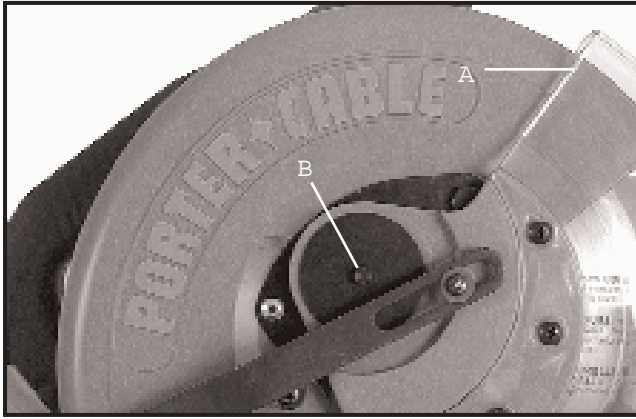

Fig. 32

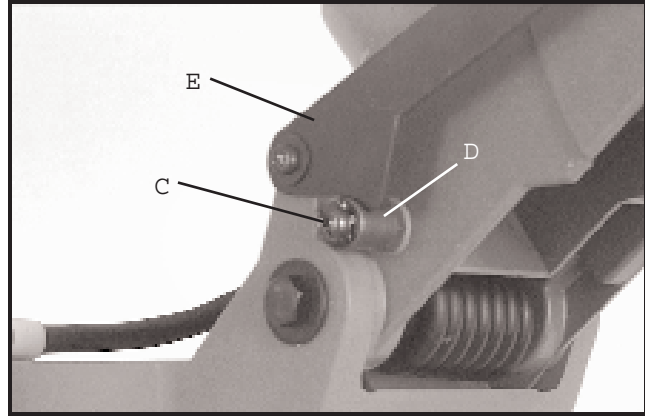

Fig. 33

ADJUSTING BLADE GUARD

1. After an extended period of time, the movable blade guard (A) Fig. 32, might become sloppy and move erratically when the cuttinghead is lowered. This can be easily corrected by slightly tightening nut (B) until the lower blade guard (A) moves smoothly.

2. As soon as the cuttinghead begins to lower, the lower blade guard (A) Fig. 32, should begin to move. If it does not, simply loosen screw (C) Fig. 33, and rotate eccentric (D) so that the eccentric (D) is contacting the actuating arm (E) when the cuttinghead is in the top position. Then tighten screw (C).

ADJUSTING THE TENSION OF CUTTINGHEAD RETURN SPRING

The tension of the cuttinghead return spring has been adjusted at the factory in order that the cuttinghead returns to the up position after a cut has been made. If it ever becomes necessary to re-adjust the spring tension, proceed as follows: Turn adjusting screw (A) Fig. 34, clockwise to increase or counterclockwise to decrease the spring tension.

ADJUSTING SLIDING FIT BETWEEN CUTTINGHEAD ARM AND TRUNNION

After a long period of time it may become necessary to adjust the sliding fit between the cuttinghead arm (B) Fig. 34, and the trunnion (C) by tightening nut (D). Correct adjustment is when a good snug sliding fit is obtained between these two parts. This adjustment should not be too tight that it restricts the sliding movement of the cuttinghead arm (B) or too loose that it affects the accuracy of the saw cut.

ADJUSTING DOWNWARD TRAVEL OF SAW BLADE

The downward travel of the saw blade was adjusted at the factory to prevent the saw blade from contacting any metal surfaces of the machine. If an adjustment is ever necessary to limit the downward travel of the saw blade for operations such as dado cutting (see section of manual on DADO CUTTING), loosen wing nut (E) Fig. 34, and make adjustment by turning adjusting screw (F). Tighten wing nut (E) after adjustment is completed.

LOCKING CUTTINGHEAD GUIDE RODS

The cuttinghead guide rods (G) Fig. 34, can be locked in place in order to use the saw as a conventional miter saw (using the saw as a chop saw instead of a sliding saw) by tightening lock knob (H). When using the saw as a chop saw, the cuttinghead should be all the way to the rear position before locking in place.

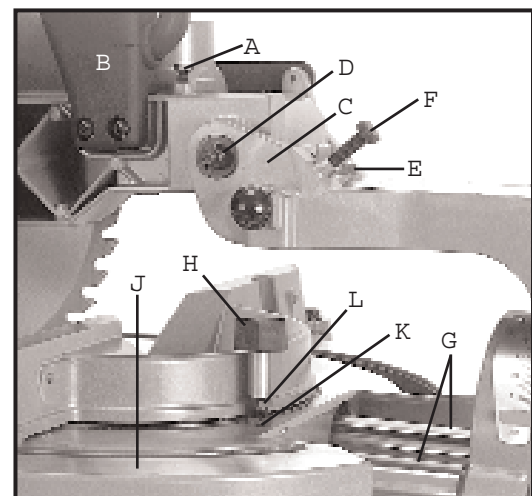

Fig. 34

ADJUSTING SLIDING FIT BETWEEN GUIDE RODS AND TABLE ASSEMBLY

To adjust the sliding fit between guide rods (G) Fig. 34, and table assembly (J), remove lock knob (H) and loosen locknut (K). With wrenches provided, hold locknut (K) while turning adjusting nut (L) clockwise to increase or counterclockwise to decrease the sliding action of the guide rods (G). This adjustment should not be too tight that it restricts the sliding movement of the rods or too loose that it affects the accuracy of the saw cut. When correct adjustment is made, hold adjusting nut (L) and tighten locknut (K) with wrenches provided. Replace lock knob (H). Periodically lubricate guide rods (G) using a light oil or spray lubricant to keep the guide rods (G) sliding smoothly.

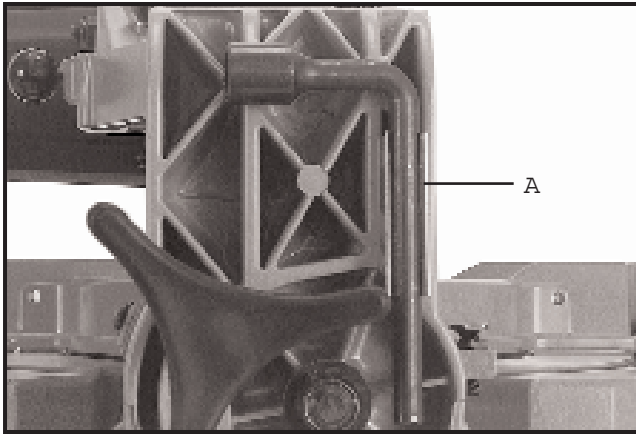

Fig. 35

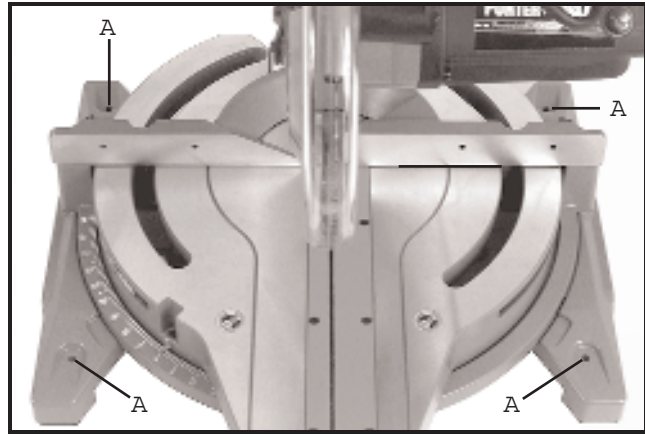

Fig. 36

TOOL STORAGE

A clip is provided on the rear of the saw and provides a convenient storage area for wrench (A) Fig. 35, as shown.

FASTENING THE SAW TO A WORKBENCH

Before operating the saw, make sure it is firmly mounted to a workbench or other supporting surface. Four holes (A) Fig. 36, are provided for fastening the saw to a supporting surface.

USING THE SAW ON SAW HORSES

Fig. 37 illustrates the saw placed for use on saw horses. Notches in the front and rear of the mounting feet are designed to fit conveniently on saw horses.

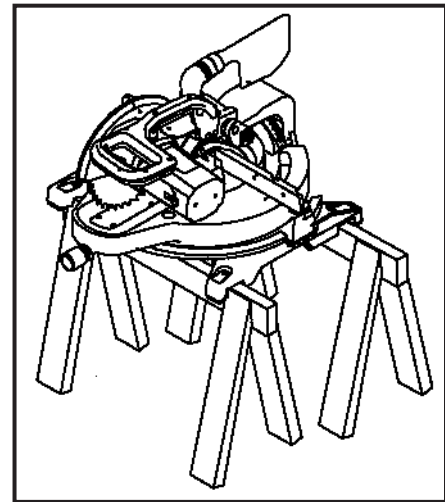

Fig. 37

USING SAW WITH 2 X 4 EXTENSIONS

Fig. 38 illustrates the saw being used with 2 x 4 extensions. Note that notches in the front and rear of the mounting feet (K) are designed to fit and fasten to the top of the two 2 x 4 s (P). The length of the two 2 x 4 s (P) can vary depending on your preference. The distance from the top of the 2 x 4 s (P) to the saw table is 3¹/₂".. 2". This enables you to nail or fasten standard 2 x 4 s (R) to the 2 x 4 s (P), as shown. The top of the 2 x 4 s (R) will then be in alignment with the saw table, providing support for long workpieces. If desired, fence extensions (S) made of 2 x 2 s can be aligned with fence (T) and bolted to 2 x 4 s (R).

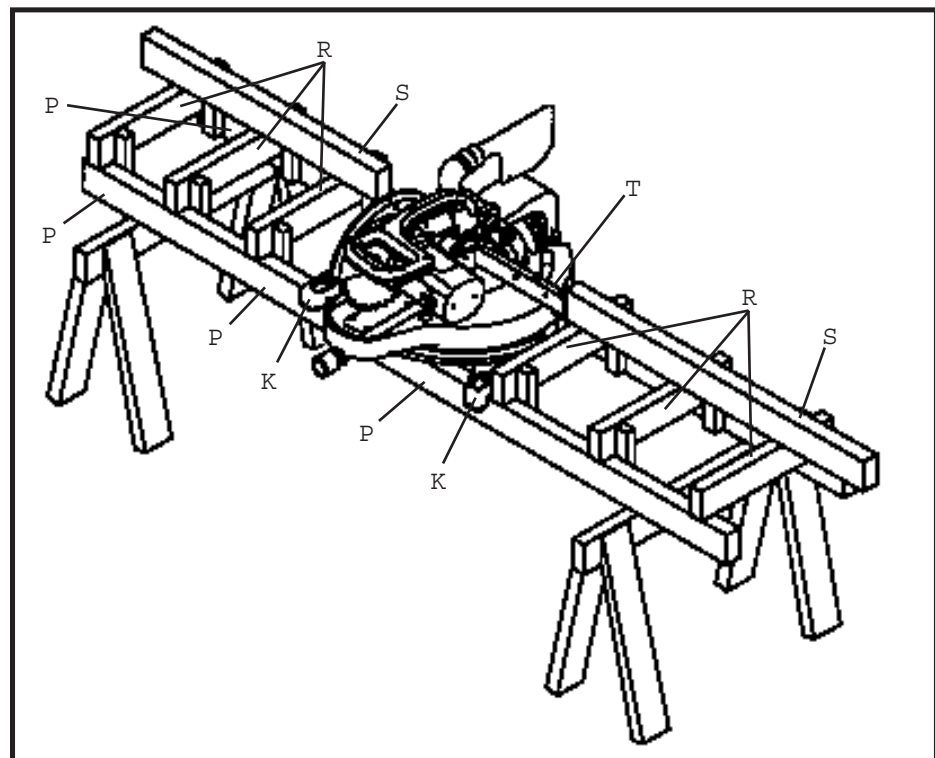

Fig. 38

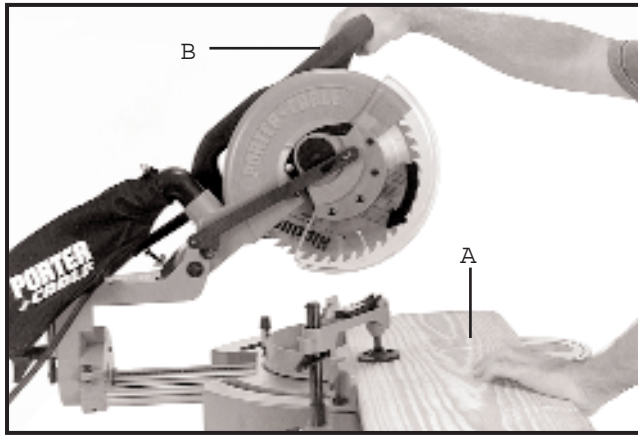

Fig. 39

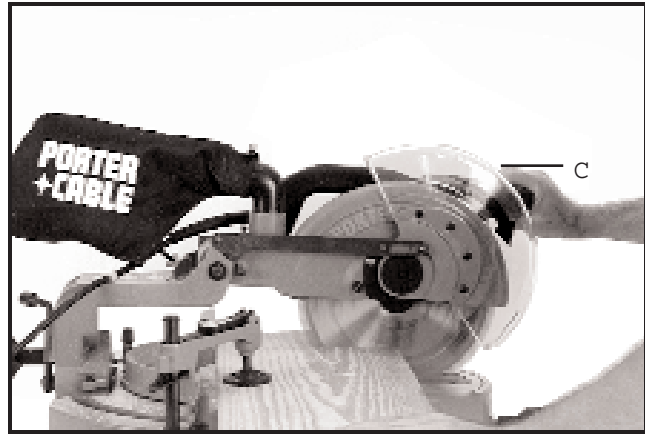

Fig. 40

OPERATION

CORRECT OPERATING PROCEDURE FOR SLIDE CUTTING

WARNING: SLIDE CUTTING BY PULLING THE SAW TO WARDS THE OPERATOR CAN BE DANGEROUS, CAUSING THE SAW TO KICK UPWARDS AND TO WARDS THE OPERATOR. ALWAYS PUSH THE SAW FORWARD, AWAY FROM THE OPERATOR, AND TO WARDS THE FENCE WHEN SLIDE CUTTING. The following steps illustrate the proper operating procedure to follow when slide cutting with your compound slide saw.

1. Place the workpiece (A) on the table and against the fence, as shown in Fig. 39. Grasp the cuttinghead handle (B) but do not turn the saw on at this time.
2. Pull the cuttinghead (C) Fig. 40, toward you, with the cuttinghead in the up position. After the cuttinghead is pulled toward you, compress switch trigger to turn the saw on, as shown.
3. Push down on the cuttinghead (C) Fig. 41, with the blade running, as shown.
4. Push the cuttinghead (C) Fig. 42, forward toward the fence, making the cut as shown.

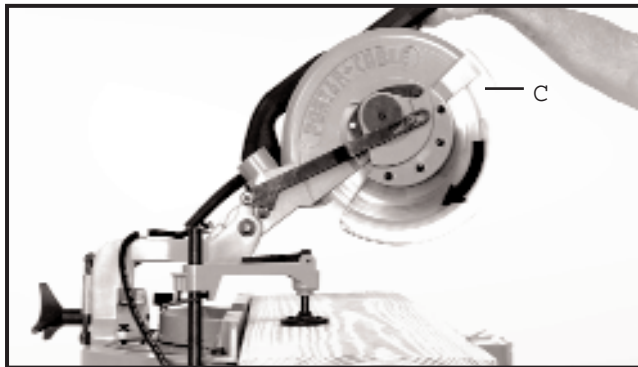

Fig. 41

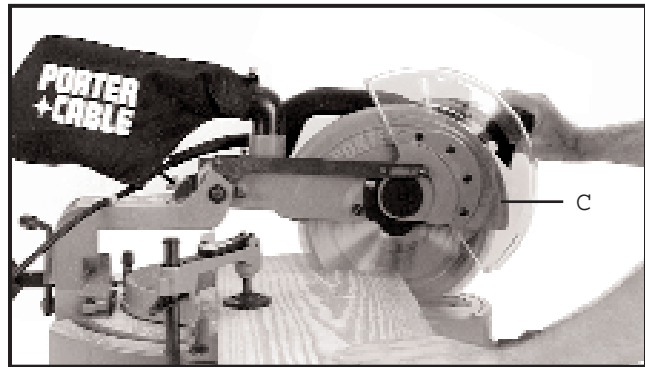

Fig. 42

5. Fig. 43 illustrates the completed cut. Release the switch trigger and keep the cuttinghead in the down position until the blade (D) comes to a complete stop.

6. After the blade has stopped, raise the cuttinghead (C) to the up position, as shown in Fig. 44.

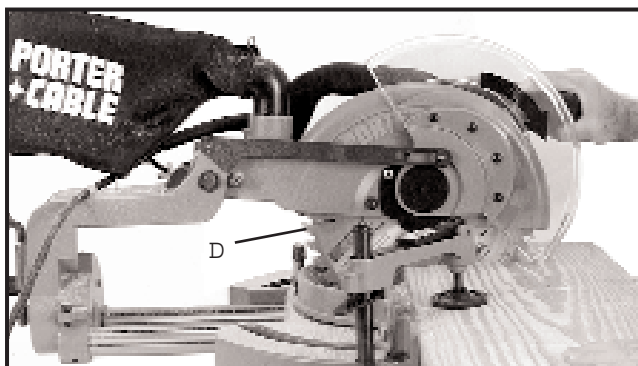

Fig. 43

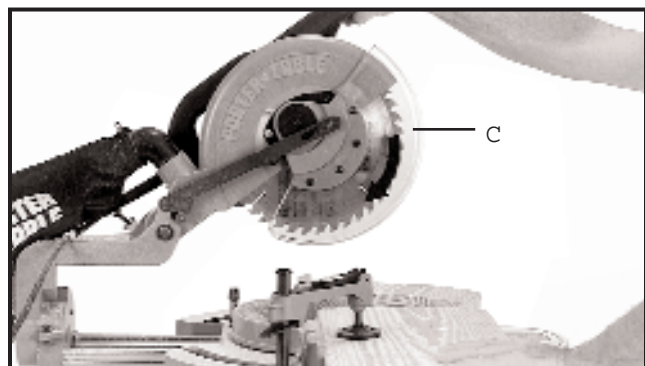

Fig. 44

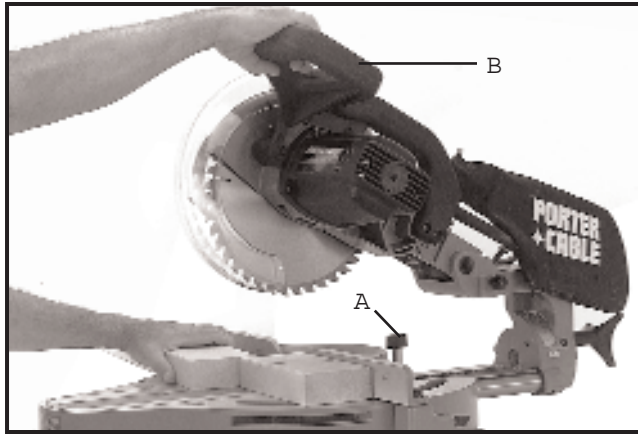

Fig. 45

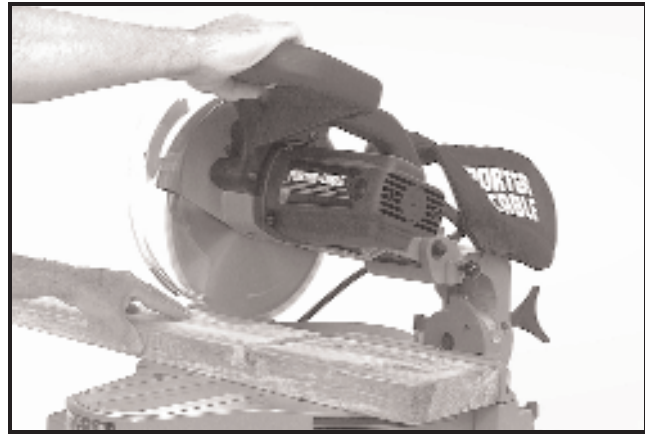

Fig. 46

USING SAW AS A CHOP SAW

When cutting material that is narrow enough to allow the saw blade to cut through in a chopping motion (similar to a conventional miter saw) instead of sliding the saw blade through the workpiece, the sliding action of the saw must be locked in the rear position, as shown in Fig. 45, by tightening lock knob (A). The cuttinghead (B) is pushed straight down to make the cut. After the cut is completed, release the switch trigger and let the blade come to a complete stop before returning the cuttinghead to the up position.

DADO CUTTING

Dado cutting can easily be accomplished with your compound slide saw, as shown in Fig. 46, using a single saw blade and moving the workpiece sideways the width of the saw blade after each cut. The cut is made in the conventional way as explained in the section CORRECT OPERATING PROCEDURE and the downward travel of the saw blade is adjusted for the depth of the dado as explained in the section ADJUSTING DOWNWARD TRAVEL OF SAW BLADE.

CUTTING CROWN MOULDING

One of the many features of your saw is the ease of cutting crown moulding. The following is an example of cutting both inside and outside corners on 52° ... 38° degree wall angle crown moulding.

NOTE: When cutting 45 degree wall angle crown moulding, the following procedure for inside and outside corners is the same with the exception that the bevel position will always be at 30 degrees and the miter position will be 35° ... 4° degrees to the right or left

1. Move the table to the 31° ... 8° degree right miter position and lock the table in position.

NOTE: A positive stop is provided to find this angle quickly.

2. Tilt the saw blade to the 33° ... 8° degree left bevel position and tighten bevel lock handle.

NOTE: A triangle indicator is provided on the bevel scale to find this angle quickly.

3. Place the crown moulding on the table with the CEILING EDGE of the moulding against the fence, and make the cut, as shown in Fig. 47.

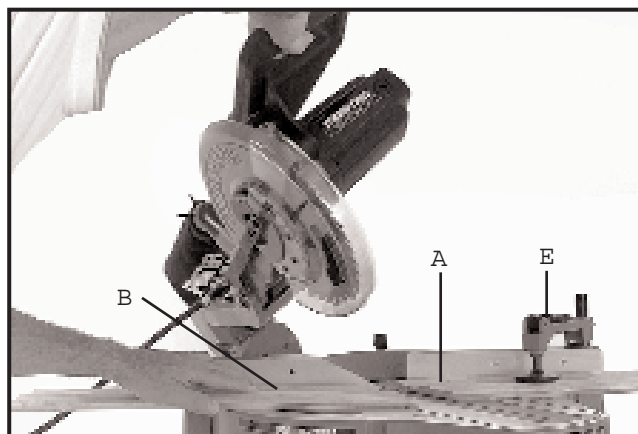

Fig. 47

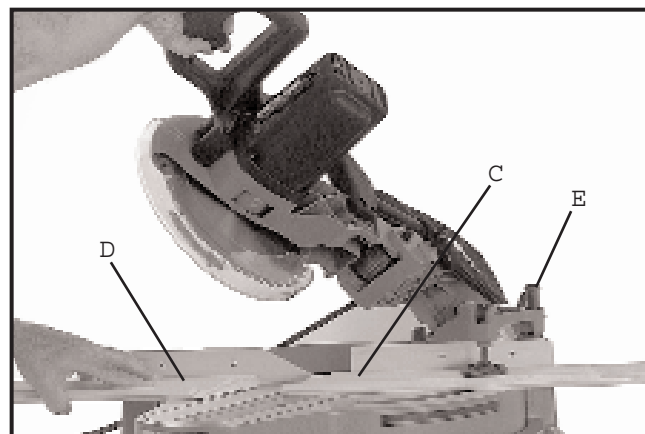

Fig. 48

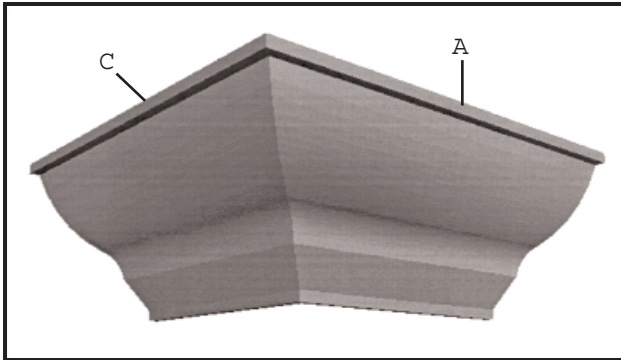

Fig. 49

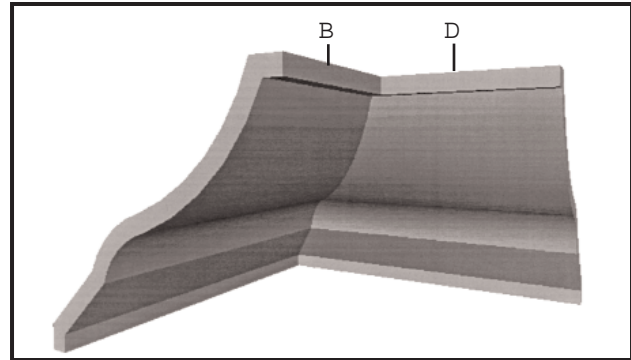

Fig. 50

NOTE: The piece of crown moulding used for the outside corner will always be on the right hand side of the blade, as shown at (A) Fig. 47. The piece of crown moulding used for the inside corner will always be on the left hand side of the blade, as shown at (B) Fig. 47. Note that the standard equipment work clamp (E) is being used to hold the workpiece in position.

- To make the matching halves of the inside and outside corners, simply rotate the table to the 31.5 degree left miter position.

NOTE: A positive stop is provided to find this angle quickly. The saw blade is already tilted to the 33.5 degree bevel position from the previous cut.

- Place the crown moulding on the table with the WALL EDGE of the crown moulding against the fence and make the cut. Again, the piece of crown moulding used for the outside corner will always be on the right side of the blade, as shown at (C) Fig. 48. The piece of crown moulding used for the inside corner will always be on the left side of the blade, as shown at (D) Fig. 48. Again, the standard equipment work clamp (E) is being used to hold the workpiece in position.

- Fig. 49 illustrates the two outside corner pieces; (A) being the piece cut at (A) Fig. 47, and (C) being the piece cut at (C) Fig. 48.

- Fig. 50 illustrates the two inside corner pieces; (B) being the piece cut at (B) Fig. 47, and (D) being the piece cut at (D) Fig. 48.

MAINTENANCE

CHANGING THE BLADE

WARNING: USE ONLY CROSS-CUTTING SAW BLADES. WHEN USING CARBIDE TIPPED BLADES BE SURE THE HOOK ANGLE IS 5 DEGREES OR LESS. DO NOT USE BLADES WITH DEEP GULLETS AS THEY CAN DEFLECT AND CONTACT GUARD. USE ONLY BLADES RATED FOR OPERATION OF AT LEAST 6000 RPM WITH 5/8" ARBOR HOLES.

- DISCONNECT THE SAW FROM THE POWER SOURCE.
- Using the special wrench (A) Fig. 51, supplied, loosen screw (B) to free arbor cover (C).
- Rotate arbor cover (C) Fig. 52, and lower guard (D) to the up position, as shown.

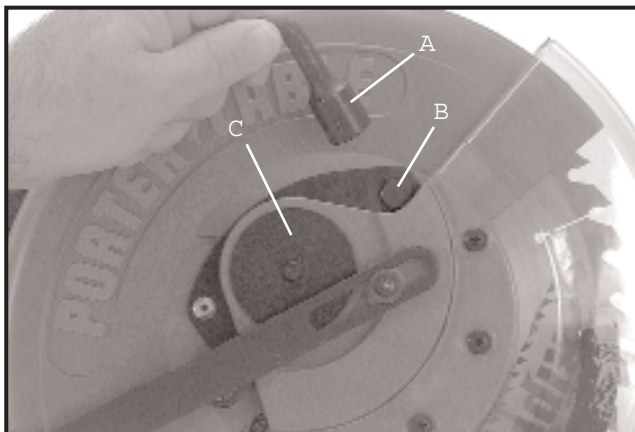

Fig. 51

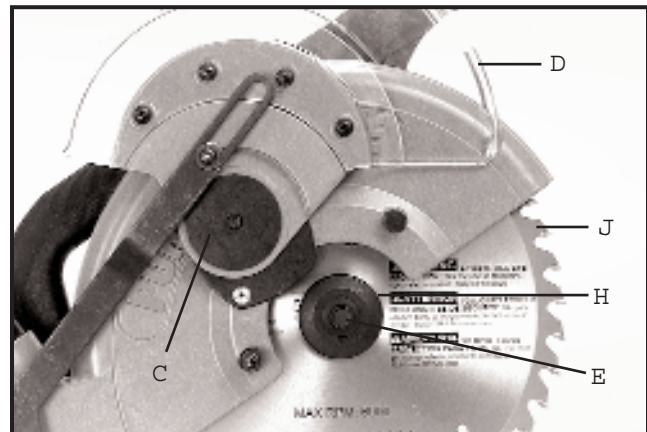

Fig. 52

4. Remove arbor screw (E) Fig. 52, by turning screw (E) clockwise while at the same time pressing in on arbor lock (F) Fig. 53, to keep arbor from turning. Remove screw (E) Fig. 52, outside blade flange (H) and blade (J). DO NOT REMOVE INSIDE BLADE FLANGE.

5. Make sure the inside surfaces of both the inside and outside blade flanges are clean and free from any foreign substance.

6. Make sure the inside blade flange is completely on the arbor with the flats in the flange engaged with the flats on the arbor.

7. Install new blade (J) Fig. 52, outside blade flange (H) and arbor screw (E). Turn arbor screw (E) counterclockwise to tighten while pressing in on arbor lock (F) Fig. 53, to keep arbor from turning. IMPORTANT: Make sure flats in outside blade flange (H) Fig. 52, are engaged with flats on arbor shaft and that teeth of saw blade (J) are pointing down at the front, as shown in Fig. 52.

8. Rotate arbor cover (C) Fig. 51, until hook in cover is engaged under screw (B) and tighten screw (B) which was loosened in STEP 2.

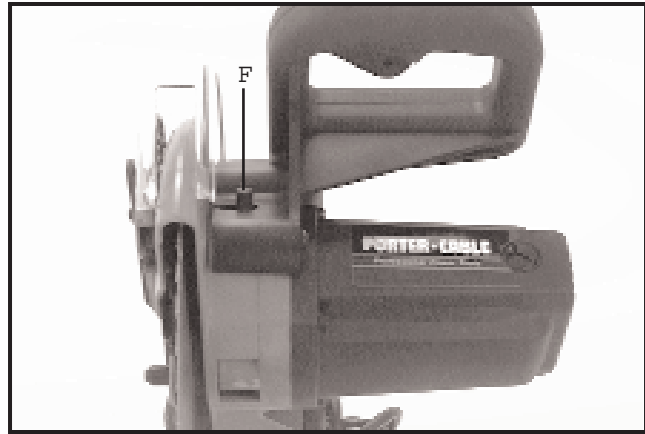

Fig. 53

BRUSH INSPECTION AND REPLACEMENT

CAUTION: BEFORE INSPECTING BRUSHES, DISCONNECT THE MACHINE FROM THE POWER SOURCE.

Brush life varies. It depends on the load on the motor. Check the brushes after the first 100 hours of use for a new machine, or after a new set of brushes has been installed.

After the first check, examine them after about 10 hours of use until such time that replacement is necessary.

The brush holders (A) Fig. 54, are located on the motor housing opposite each other. Fig. 55, illustrates one of the brushes removed for inspection. When the carbon on either brush (B) is worn to $\frac{3}{16}$ " in length or if either spring or shunt wire (C) is burned or damaged in any way, replace both brushes. If the brushes are found serviceable after removing, reinstall them in the same position as removed.

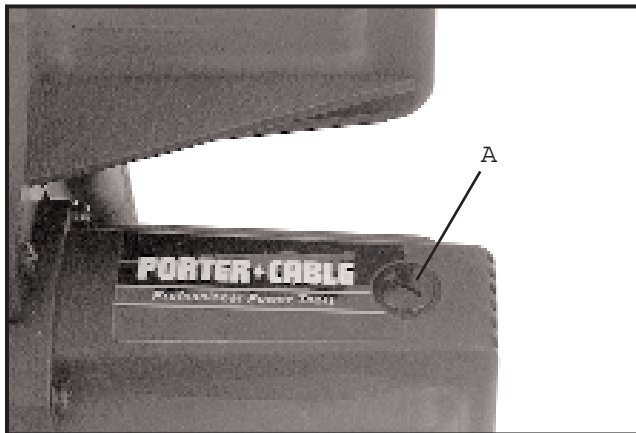

Fig. 54

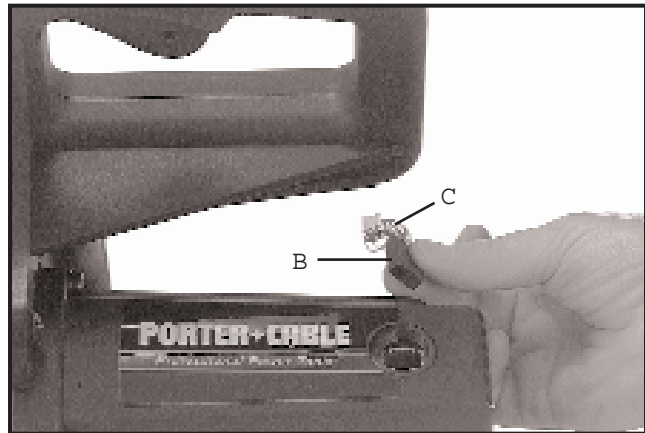

Fig. 55

KEEP TOOL CLEAN

Periodically blow out all air passages with dry compressed air. Clean all plastic parts with a soft damp cloth. NEVER use solvents to clean plastic parts. They could possibly dissolve or otherwise damage the material.

CAUTION: WEAR SAFETY GLASSES WHILE USING COMPRESSED AIR.

FAILURE TO START

Should your tool fail to start, check to make sure the prongs on the cord plug are making good contact in the outlet. Also, check for blown fuses or open circuit breakers in the line.

SERVICE AND REPAIRS

All quality tools will eventually require servicing or replacement of parts due to wear from normal use. These operations should ONLY be performed by either an AUTHORIZED PORTER-CABLE SERVICE STATION or a PORTER-CABLE SERVICE CENTER. All repairs made by these agencies are fully guaranteed against defective material and workmanship. We cannot guarantee repairs made or attempted by anyone other than these agencies.

Should you have any questions about your tool, feel free to write us at any time. In any communications, please give all information shown on the nameplate of your tool (model number, type, serial number, etc.).

PORTER-CABLE LIMITED ONE YEAR WARRANTY

Porter-Cable warrants its Professional Power Tools for a period of one year from the date of original purchase. We will repair or replace, at our option, any part or parts of the product and accessories covered under this warranty which, after examination, proves to be defective in workmanship or material during the warranty period. For repair or replacement, return the complete tool or accessory, transportation prepaid, to your nearest Porter-Cable Service Center or Authorized Service Station. Proof of purchase may be required. This warranty does not apply to repair or replacement required due to misuse, abuse, normal wear and tear or repairs attempted or made by other than our Service Centers or Authorized Service Stations.

ANY IMPLIED WARRANTY, INCLUDING THE IMPLIED WARRANTIES OF MERCHANTABILITY AND FITNESS FOR A PARTICULAR PURPOSE, WILL LAST ONLY FOR ONE (1) YEAR FROM THE DATE OF PURCHASE.

To obtain information on warranty performance please write to: PORTER-CABLE CORPORATION, 4825 Highway 45 North, P.O. Box 2468, Jackson, Tennessee 38302-2468; Attention: Product Service. THE FOREGOING OBLIGATION IS PORTER-CABLE'S SOLE LIABILITY UNDER THIS OR ANY IMPLIED WARRANTY AND UNDER NO CIRCUMSTANCES SHALL PORTER-CABLE BE LIABLE FOR ANY INCIDENTAL OR CONSEQUENTIAL DAMAGES. Some states do not allow limitations on how long an implied warranty lasts or the exclusion or limitation of incidental or consequential damages, so the above limitation or exclusion may not apply to you.

This warranty gives you specific legal rights and you may also have other legal rights which vary from state to state.

PORTER-CABLE SERVICE CENTERS
(CENTROS DE SERVICIO DE PORTER-CABLE)
(CENTRE DE SERVICE PORTER-CABLE)

Parts and Repair Service for Porter-Cable Power Tools are Available at These Locations
 (Obtenga Refaccion de Partes o Servicio para su Herramienta en los Siguietes Centros de Porter-Cable)
 (Locations où vous trouverez les pièces de rechange nécessaires ainsi qu'un service d'entretien)

ARIZONA Tempe 85282 (Phoenix) 2400 West Southern Avenue Suite 105 Phone: (602) 437-1200 Fax: (602) 437-2200	GEORGIA Forest Park 30297 (Atlanta) 5442 Frontage Road, Suite 112 Phone: (404) 608-0006 Fax: (404) 608-1123	MINNESOTA Minneapolis 55429 4315 68th Avenue North Phone: (612) 561-9080 Fax: (612) 561-0653	Cleveland 44125 8001 Sweet Valley Drive Unit #19 Phone: (216) 447-9030 Fax: (216) 447-3097
CALIFORNIA Ontario 91761 (Los Angeles) 3949A East Guasti Road Phone: (909) 390-5555 Fax: (909) 390-5554	ILLINOIS Addison 60101 (Chicago) 311 Laura Drive Phone: (630) 628-6100 Fax: (630) 628-0023	MISSOURI North Kansas City 64116 1141 Swift Avenue P.O. Box 12393 Phone: (816) 221-2070 Fax: (816) 221-2897	PENNSYLVANIA Willow Grove 19090 520 North York Road Phone: (215) 658-1430 Fax: (215) 658-1433
San Leandro 94577 (Oakland) 3039 Teagarden Street Phone: (510) 357-9762 Fax: (510) 357-7939	MARYLAND Elkridge 21075 (Baltimore) 7397-102 Washington Blvd. Phone: (410) 799-9394 Fax: (410) 799-9398	St. Louis 63119 7574 Watson Road Phone: (314) 968-8950 Fax: (314) 968-2790	TENNESSEE Nashville 37214 2262 Lebanon Pike Phone: (615) 882-0320 Fax: (615) 882-0051
COLORADO Denver 80216 5855 Stapleton Drive North Suite A-140 Phone: (303) 370-6909 Fax: (303) 370-6969	MASSACHUSETTS Braintree 02185 (Boston) 719 Granite Street Phone: (781) 848-9810 Fax: (781) 848-6759	NEW YORK Flushing 11365-1595 (N.Y.C.) 175-25 Horace Harding Expwy. Phone: (718) 225-2040 Fax: (718) 423-9619	TEXAS Dallas 75220 10720 N. Stemmons Freeway Phone: (214) 353-2996 Fax: (214) 350-3943
FLORIDA Davie 33314 (Miami) 4343 South State Rd. 7 (441) Unit #107 Phone: (954) 321-6635 Fax: (954) 321-6638	MICHIGAN Troy 48083 (Detroit) 1355 Combermere Phone: (248) 597-5000 Fax: (248) 597-5004	NORTH CAROLINA Charlotte 28209 4303-B South Boulevard Phone: (704) 525-4410 Fax: (704) 525-0618	Houston 77055 West 10 Business Center 1008 Wirt Road, Suite 120 Phone: (713) 682-0334 Fax: (713) 682-4867
Tampa 33609 4538 W. Kennedy Boulevard Phone: (813) 877-9585 Fax: (813) 289-7948		OHIO Columbus 43214 4560 Indianola Avenue Phone: (614) 263-0929 Fax: (614) 263-1238	WASHINGTON Renton 98055 (Seattle) 268 Southwest 43rd Street Phone: (425) 251-6680 Fax: (425) 251-9337

Authorized Service Stations are located in many large cities. Telephone 800-487-8665 or 901-541-6042 for assistance locating one. Parts and accessories for Porter-Cable products should be obtained by contacting any Porter-Cable Distributor, Authorized Service Center, or Porter-Cable Factory Service Center. If you do not have access to any of these, call 888-848-5175 and you will be directed to the nearest Porter-Cable Factory Service Center. Las Estaciones de Servicio Autorizadas están ubicadas en muchas grandes ciudades. Llame al 800-487-8665 al 901-541-6042 para obtener asistencia a fin de localizar una. Las piezas y los accesorios para los productos Porter-Cable deben obtenerse poniéndose en contacto con cualquier distribuidor Porter-Cable, Centro de Servicio Autorizado o Centro de Servicio de Fábrica Porter-Cable. Si no tiene acceso a ninguna de estas opciones, llame al 888-848-5175 y le dirigiremos al Centro de Servicio de Fábrica Porter-Cable más cercano. Des centres de service agréés sont situés dans beaucoup de grandes villes. Appelez au 800-487-8665 ou au 901-541-6042 pour obtenir de l'aide pour en repérer un. Pour obtenir des pièces et accessoires pour les produits Porter-Cable, s'adresser tout distributeur Porter-Cable, centre de service agréé ou centre de service d'usine Porter-Cable. Si vous n'avez accès à aucun de ces centres, appelez le 888-848-5175 et on vous dirigera vers le centre de service d'usine Porter-Cable le plus proche.

DELTA SERVICE CENTERS

ALBERTA Bay 6, 2520-23rd St. N.E. Calgary, Alberta T2E 8L2 Phone: (403) 735-6166 Fax: (403) 735-6144	MANITOBA 1699 Dublin Avenue Winnipeg, Manitoba R3H 0H2 Phone: (204) 633-9259 Fax: (204) 632-1976	QUÉBEC 1515 Ave. St-Jean Baptiste, Québec, Québec G2E 5E2 Phone: (418) 877-7112 Fax: (418) 877-7123
BRITISH COLUMBIA 8520 Baxter Place Burnaby, B.C. V5A 4T8 Phone: (604) 420-0102 Fax: (604) 420-3522	ONTARIO 505 Southgate Drive Guelph, Ontario N1H 6M7 Phone: (519) 836-2840 Fax: (519) 767-4131	1447, Begin St-Laurent, (Montréal), Québec H4R 1V8 Phone: (514) 336-8772 Fax: (514) 336-3505

The following are trademarks of PORTER-CABLE Corporation (Las siguientes son marcas registradas de PORTER-CABLE S.A.) (Les marques suivantes sont des marques de fabricant de la PORTER-CABLE Corporation): BANNER[®], LASERLOC[®], OMNIGIG[®], POCKET CUTTER[®], PORTA-BAND[®], PORTA-PLANE[®], PORTER-CABLE[®], QUICKSAND[®], SANDTRAP[®], SAW BOSS[®], SPEED-BLOC[®], SPEEDMATIC[®], SPEEDTRONIC[®], STAIR-EASE[®], THE PROFESSIONAL EDGE[®], THE PROFESSIONAL SELECT[®], TIGER CUB[®], TIGER SAW[®], TORQ-BUSTER[®], VERSA-PLANE[®], WHISPER SERIES[®], DURATRONIC[®], FRAME SAW[®], INNOVATION THAT WORKS[®], JETSTREAM[®], MICRO-SET[®], MORTEN[®], NETWORK[®], RIPTIDE[®], TRU-MATCH[®], WOODWORKER S CHOICE[®].

Trademarks noted with ® are registered in the United States Patent and Trademark Office and may also be registered in other countries. Las Marcas Registradas con el signo de ® son registradas por la Oficina de Registros y Patentes de los Estados Unidos y también pueden estar registradas en otros países. Marques déposées, indiquées par la lettre ®, sont déposées au Bureau des brevets d'invention et marques déposées aux États-Unis et pourraient être déposées aux autres pays.

Free Manuals Download Website

<http://myh66.com>

<http://usermanuals.us>

<http://www.somanuals.com>

<http://www.4manuals.cc>

<http://www.manual-lib.com>

<http://www.404manual.com>

<http://www.luxmanual.com>

<http://aubethermostatmanual.com>

Golf course search by state

<http://golfingnear.com>

Email search by domain

<http://emailbydomain.com>

Auto manuals search

<http://auto.somanuals.com>

TV manuals search

<http://tv.somanuals.com>