

Do NOT REMOVE

OWNER'S MANUAL

MODEL NUMBER X1844A

**18.0 HORSEPOWER
44" MOWER
6 SPEED
YARD TRACTOR**

- **Assembly**
 - **Operation**
 - **Customer Responsibilities**
 - **Service and Adjustments**
 - **Repair Parts**

For Parts and Service, contact our authorized distributor: in the U. S., call 1-800-849-YARD; in Canada, call 1-800-263-0660

Poulan

FILE COPY

139700 Rev. 1 5.18.93
Printed in the U.S.A.



SAFETY RULES

Safe Operation Practices for Ride-On Mowers



IMPORTANT: THIS CUTTING MACHINE IS CAPABLE OF AMPUTATING HANDS AND FEET AND THROWING OBJECTS. FAILURE TO OBSERVE THE FOLLOWING SAFETY INSTRUCTIONS COULD RESULT IN SERIOUS INJURY OR DEATH.

I. GENERAL OPERATION

- Read, understand, and follow all instructions in the manual and on the machine before starting.
- Only allow responsible adults, who are familiar with the instructions, to operate the machine.
- Clear the area of objects such as rocks, toys, wire, etc., which could be picked up and thrown by the blade.
- Be sure the area is clear of other people before mowing. Stop machine if anyone enters the area.
- Never carry passengers.
- Do not mow in reverse unless absolutely necessary. Always look down and behind before and while backing.
- Be aware of the mower discharge direction and do not point it at anyone. Do not operate the mower without either the entire grass catcher or the guard in place.
- Slow down before turning.
- Never leave a running machine unattended. Always turn off blades, set parking brake, stop engine, and remove keys before dismounting.
- Turn off blades when not mowing.
- Stop engine before removing grass catcher or unclogging chute.
- Mow only in daylight or good artificial light.
- Do not operate the machine while under the influence of alcohol or drugs.
- Watch for traffic when operating near or crossing roadways.
- Use extra care when loading or unloading the machine into a trailer or truck.

II. SLOPE OPERATION

Slopes are a major factor related to loss-of-control and tipover accidents, which can result in severe injury or death. All slopes require extra caution. If you cannot back up the slope or if you feel uneasy on it, do not mow it.

DO:

- Mow up and down slopes, not across.
- Remove obstacles such as rocks, tree limbs, etc.
- Watch for holes, ruts, or bumps. Uneven terrain could overturn the machine. *Tall grass can hide obstacles.*
- Use slow speed. Choose a low gear so that you will not have to stop or shift while on the slope.
- Follow the manufacturer's recommendations for wheel weights or counterweights to improve stability.
- Use extra care with grass catchers or other attachments. These can change the stability of the machine.
- Keep all movement on the slopes *slow* and *gradual*. Do not make sudden changes in speed or direction.
- Avoid starting or stopping on a slope. If tires lose traction, disengage the blades and proceed slowly *straight* down the slope.

DO NOT:

- Do not turn on slopes unless necessary, and then, turn slowly and gradually downhill, if possible.
- Do not mow near drop-offs, ditches, or embankments. The mower could suddenly turn over if a wheel is over the edge of a cliff or ditch, or if an edge caves in.
- Do not mow on wet grass. Reduced traction could cause sliding.
- Do not try to stabilize the machine by putting your foot on the ground.
- Do not use grass catcher on steep slopes.

III. CHILDREN

Tragic accidents can occur if the operator is not alert to the presence of children. Children are often attracted to the machine and the mowing activity. *Never* assume that children will remain where you last saw them.

- Keep children out of the mowing area and under the watchful care of another responsible adult.
- Be alert and turn machine off if children enter the area.
- Before and when backing, look behind and *down* for small children.
- Never carry children. They may fall off and be seriously injured or interfere with safe machine operation.
- Never allow children to operate the machine.
- Use extra care when approaching blind corners, shrubs, trees, or other objects that may obscure vision.

IV. SERVICE

- Use extra care in handling gasoline and other fuels. They are flammable and vapors are explosive.
 - Use only an approved container.
 - Never remove gas cap or add fuel with the engine running. Allow engine to cool before refueling. Do not smoke.
 - Never refuel the machine indoors.
 - Never store the machine or fuel container inside where there is an open flame, such as a water heater.
- Never run a machine inside a closed area.
- Keep nuts and bolts, especially blade attachment bolts, tight and keep equipment in good condition.
- Never tamper with safety devices. Check their proper operation regularly.
- Keep machine free of grass, leaves, or other debris build-up. Clean oil or fuel spillage. Allow machine to cool before storing.
- Stop and inspect the equipment if you strike an object. Repair, if necessary, before restarting.
- Never make adjustments or repairs with the engine running.
- Grass catcher components are subject to wear, damage, and deterioration, which could expose moving parts or allow objects to be thrown. Frequently check components and replace with manufacturer's recommended parts, when necessary.
- Mower blades are sharp and can cut. Wrap the blade(s) or wear gloves, and use extra caution when servicing them.
- Check brake operation frequently. Adjust and service as required.



Look for this symbol to point out important safety precautions. It means CAUTION!!! BECOME ALERT!!! YOUR SAFETY IS INVOLVED.



CAUTION: Always disconnect spark plug wire and place wire where it cannot contact spark plug in order to prevent accidental starting when setting up, transporting, adjusting or making repairs.

CONGRATULATIONS on your purchase of a new tractor. It has been designed, engineered and manufactured to give you the best possible dependability and performance.

Should you experience any problem you cannot easily remedy, please contact your nearest authorized service center. We have competent, well-trained technicians and the proper tools to service or repair this tractor.

Please read and retain this manual. The instructions will enable you to assemble and maintain your tractor properly. Always observe the "SAFETY RULES".

MODEL NUMBER	X1844A
SERIAL NUMBER	_____
DATE OF PURCHASE	_____
THE MODEL AND SERIAL NUMBERS WILL BE FOUND ON A PLATE UNDER THE SEAT.	
YOU SHOULD RECORD BOTH SERIAL NUMBER AND DATE OF PURCHASE AND KEEP IN A SAFE PLACE FOR FUTURE REFERENCE.	

CUSTOMER RESPONSIBILITIES

- Read and observe the safety rules.
- Follow a regular schedule in maintaining, caring for and using your tractor.
- Follow the instructions under "Customer Responsibilities" and "Storage" sections of this manual.

PRODUCT SPECIFICATIONS

HORSEPOWER:	18.0		
GASOLINE CAPACITY:	3.5 GALLONS UNLEADED REGULAR		
OIL (3.0 PINTS):	SAE 30 (above 32° F) SAE 5W-30 (below 32° F)		
SPARK PLUG (GAP .025 IN.):	CHAMPION RJ19LM		
VALVE CLEARANCE:	INTAKE .004 - .006 IN. EXHAUST .007 - .009 IN.		
GROUND SPEED:	FORWARD:		
	1st	.71	MPH
	2nd	1.05	MPH
	3rd	1.82	MPH
	4th	3.24	MPH
	5th	4.12	MPH
	6th	5.29	MPH
	REVERSE:	1.62	MPH
TIRE PRESSURE:	FRONT:	14 PSI	
	REAR:	10 PSI	
CHARGING SYSTEM:	5 AMPS BATTERY 5 AMPS HEADLIGHTS		
BLADE BOLT TORQUE:	30-35 FT. LBS.		

WARNING: This tractor is equipped with an internal combustion engine and should not be used on or near any unimproved forest-covered, brush-covered or grass-covered land unless the engine's exhaust system is equipped with a spark arrester meeting applicable local or state laws (if any). If a spark arrester is used, it should be maintained in effective working order by the operator.

In the state of California the above is required by law (Section 4442 of the California Public Resources Code). Other states may have similar laws. Federal laws apply on federal lands. A spark arrester for the muffler is available through your nearest authorized service center (See REPAIR PARTS section of this manual).

LIMITED WARRANTY

The Manufacturer warrants to the original consumer purchaser that this product as manufactured is free from defects in materials and workmanship. For a period of two (2) years from date of purchase by the original consumer purchaser, we will repair or replace, at our option, without charge for parts or labor incurred in replacing parts, any part which we find to be defective due to materials or workmanship. This Warranty is subject to the following limitations and exclusions.

1. This warranty does not apply to the engine, transaxle/transmission components, battery (except as noted below) or components parts thereof. Please refer to the applicable manufacturer's warranty on these items.
2. Transportation charges for the movement of any power equipment unit or attachment are the responsibility of the purchaser. Transportation charges for any parts submitted for replacement under this warranty must be paid by the purchaser unless such return is requested by American Yard Products, Inc.
3. Battery Warranty: On products equipped with a Battery, we will replace, without charge to you, any battery which we find to be defective in manufacture, during the first ninety (90) days of ownership. After ninety (90) days, we will exchange the Battery, charging you 1/12 of the price of a new Battery for each full month from the date of the original sale. Battery must be maintained in accordance with the instructions furnished.
4. The Warranty period for any products used for rental or commercial purposes is limited to 90 days from the date of original purchase.
5. This Warranty applies only to products which have been properly assembled, adjusted, operated, and maintained in accordance with the instructions furnished. This Warranty does not apply to any product which has been subjected to alteration, misuse, abuse, improper assembly or installation, delivery damage, or to normal wear of the product.
6. Exclusions: Excluded from this Warranty are belts, blades, blade adapters, normal wear, normal adjustments, standard hardware and normal maintenance.
7. In the event you have a claim under this Warranty, you must return the product to an authorized service dealer.

Should you have any unanswered questions concerning this Warranty, please contact:

American Yard Products, Inc.
Service Department
P.O. Box 1687
Orangeburg, SC 29116 USA

In Canada contact:
AYP Canada, Inc.
1040 Jayson Court
Mississauga, Ontario
L4W 2V5

giving the model number, serial number and date of purchase of your product and the name and address of the authorized dealer from whom it was purchased.

THIS WARRANTY DOES NOT APPLY TO INCIDENTAL OR CONSEQUENTIAL DAMAGES AND ANY IMPLIED WARRANTIES ARE LIMITED TO THE SAME TIME PERIODS STATED HEREIN FOR OUR EXPRESSED WARRANTIES. Some areas do not allow the limitation of consequential damages or limitations of how long an implied Warranty may last, so the above limitations or exclusions may not apply to you. This Warranty gives you specific legal rights, and you may have other rights which vary from locale to locale.

This is a limited Warranty within the meaning of that term as defined in the Magnuson-Moss Act of 1975.

CONTENTS OF HARDWARE PACK

Parts Bag contents shown full size

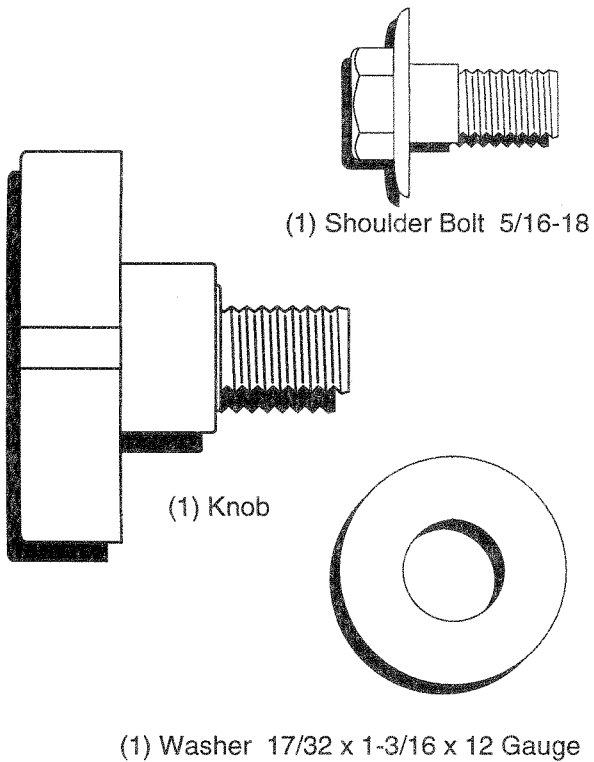

Parts packed separately in carton

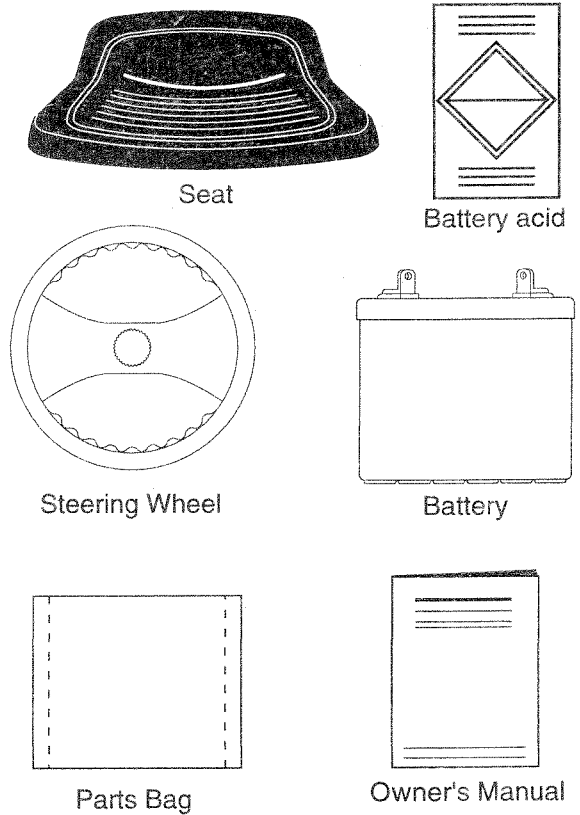

Parts bag contents not shown full size

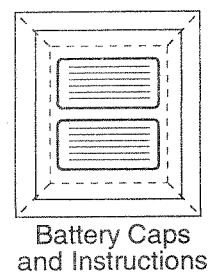
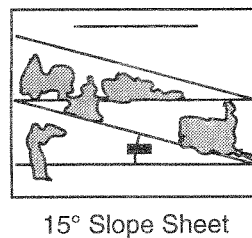
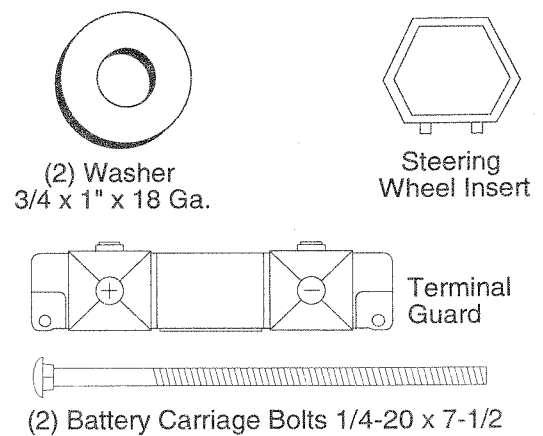
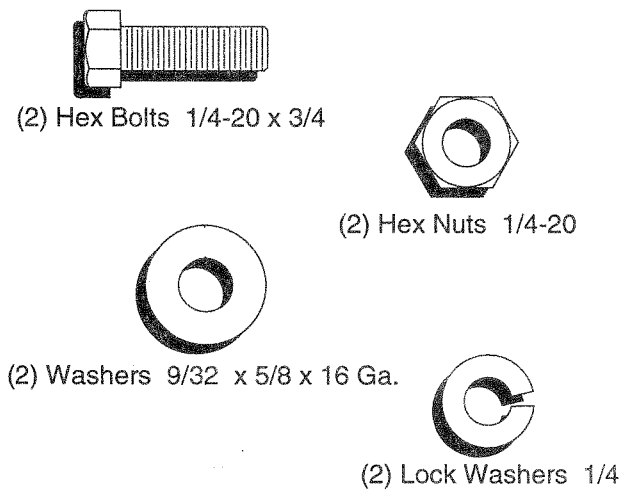

ASSEMBLY

Your new tractor has been assembled at the factory with exception of those parts left unassembled for shipping puposes. To ensure safe and proper operation of your tractor all parts and hardware you assemble must be tightened securely. Use the correct tools as necessary to insure proper tightness.

TOOLS REQUIRED FOR ASSEMBLY

A socket wrench set will make assembly easier. Standard wrench sizes are listed.

- (2) 7/16" wrenches
- (1) 3/4" wrench
- (1) Adjustable wrench
- (1) Tire pressure gauge
- (1) Utility knife

When right and left hand is mentioned in this manual, it means when you are in the operating position (seated behind the steering wheel).

TO REMOVE TRACTOR FROM CARTON UNPACK CARTON

- Remove all accessible loose parts and parts cartons from carton (See page 6).
- Cut along lines on the carton, from top to bottom, all four corners of carton and lay panels flat.
- Remove mower deck from skid.
- Check for any additional loose parts or cartons and remove.

BEFORE ROLLING UNIT OFF SKID ATTACH STEERING WHEEL (See Fig. 1)

- Remove locknut and large flat washer from steering shaft.
- Position front wheels of the tractor so they are pointing straight forward.
- Position steering wheel so cross bars are horizontal (left to right) and slide onto adapter.
- Secure steering wheel to steering shaft with locknut and large flat washer previously removed. Tighten securely.
- Snap steering wheel insert into center of steering wheel.
- Remove protective plastic from tractor hood and grill.

IMPORTANT: CHECK FOR AND REMOVE ANY STAPLES IN SKID THAT MAY PUNCTURE TIRES WHERE UNIT IS TO ROLL OFF SKID.

TO ROLL UNIT OFF SKID (See Fig. 10)

- Raise attachment lift lever to its highest position.
- Release parking brake by depressing clutch/brake pedal.
- Place gearshift lever in "NEUTRAL" position.
- Roll tractor backwards off skid.

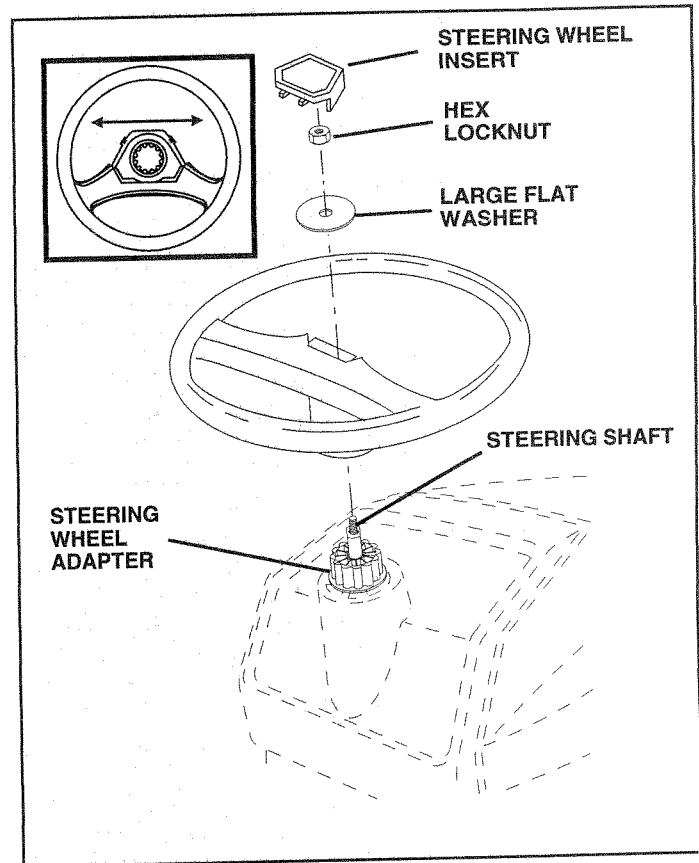

FIG. 1

ASSEMBLY

HOW TO SET UP YOUR TRACTOR PREPARE BATTERY (See Fig. 2)



CAUTION: Wear eye and face shield.

Wash hands or clothing immediately if accidentally in contact with battery acid.

Do not smoke. Fumes from charged battery acid are explosive.

Read the instructions included with the battery vent caps. Always wear gloves, clothing and goggles to protect your hands, skin and eyes.

Your tractor has a battery charging system which is sufficient for normal use. However, periodic charging of the battery with an automotive charger will extend its life.

- See instructions packed with vent caps in parts bag.
- Fill battery with acid. Fill each cell until it reaches the bottom of the vent wells. Do not overfill.
- Allow battery to stand and settle for at least thirty minutes. After standing, check the level of acid. If below the vent wells, add more acid until the correct level is reached.

While battery is standing (after adding acid) and later, while battery is being charged, continue with assembly of tractor.

IMPORTANT: TO MAXIMIZE THE LIFE OF YOUR BATTERY, IT IS NECESSARY THAT THE BATTERY BE CHARGED BEFORE USE. FAILURE TO CHARGE BATTERY CAN RESULT IN A SHORTENED BATTERY LIFE.

- Charge battery at a rate of 6 amperes for 1 hour. Use a 12 volt battery charger. Observe all safety precautions required for battery charging.
- Check the acid level after the battery is charged. If the acid has fallen below the correct level, add distilled or iron free water.
- Install the vent caps to cover the vent wells. Wash the top of the battery with water to remove any acid, then wipe dry.
- Check battery case for leakage to make sure that no damage has occurred in handling.
- Dispose of excess battery acid. Neutralize acid for disposal by adding it to four inches of water in a five gallon plastic container. Stir with a wooden or plastic paddle while adding baking soda until the addition of more soda causes no more foaming.
- Follow instructions on how to install battery.

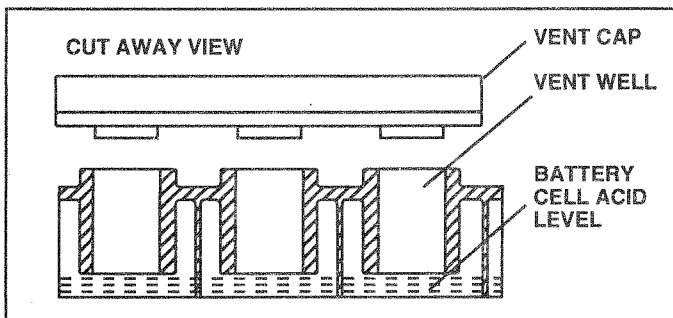

FIG. 2

INSTALL SEAT (See Fig. 3)

Adjust seat before tightening adjustment knob.

- Remove cardboard packing on seat pan.
- Place seat on pan and assemble shoulder bolt.
- Assemble adjustment knob and flat washer loosely. Do not tighten.
- Tighten shoulder bolt securely.
- Lower seat into operating position and sit on seat.
- Slide seat until a comfortable position is reached which allows you to press clutch/brake pedal all the way down.
- Get off seat without moving its adjusted position.
- Raise seat and tighten adjustment knob securely.

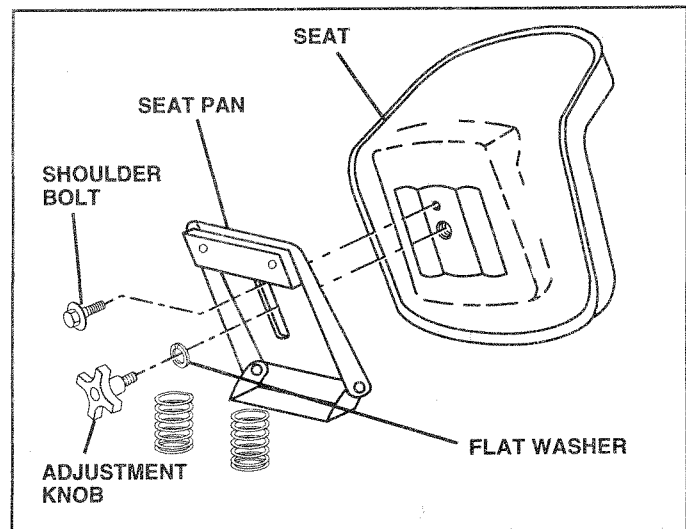

FIG. 3

CHECK TIRE PRESSURE

The tires on your tractor were overinflated at the factory for shipping purposes. Correct tire pressure is important for best cutting performance.

- Reduce tire pressure to PSI shown in "PRODUCT SPECIFICATIONS" on page 3 of this manual.

ASSEMBLY

INSTALL MOWER (See Figs. 4, 5, 6 & 7)

- Remove banding holding parallel link up against tractor.
- Remove retainer securing long hinge pin to parallel link and remove hinge pin.
- Raise attachment lift lever to its highest position.
- Remove banding from mower deck links and V-belt.
- Slide mower under tractor with discharge guard to right side of tractor.
- Attach front of mower to parallel link with long hinge pin. Secure hinge pin with retainer spring.
- Turn height adjustment knob to its lowest setting.
- Lower attachment lift lever to lower suspension arms. Remove retainer springs from lift trunnions.
- Slide trunnions through upper hole in lift brackets and secure with retainer springs.
- Pull L.H. idler pulley toward the right hand side of tractor and roll belt over mower drive pulley.

NOTE: Mower drive belt installation decal located on mower housing.

- Raise attachment lift lever to raise mower.
- Turn height adjustment knob clockwise to the middle of its travel.

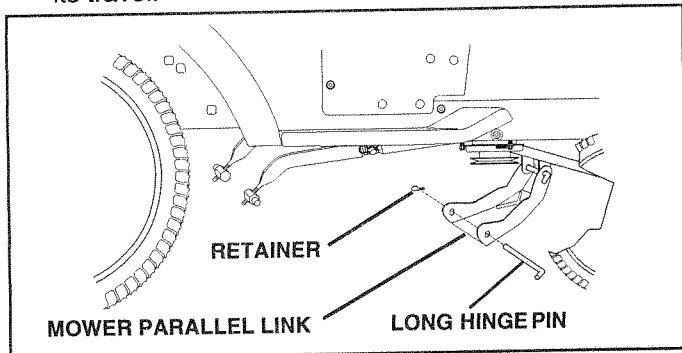

FIG. 4

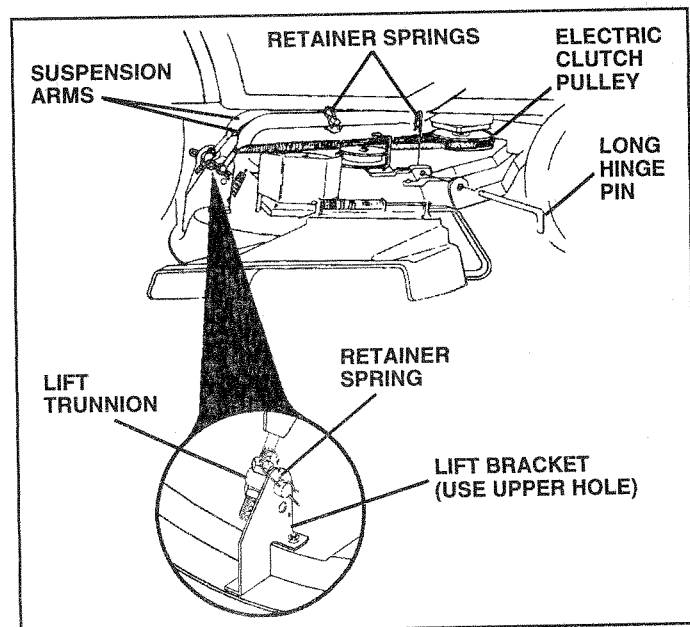

FIG. 5

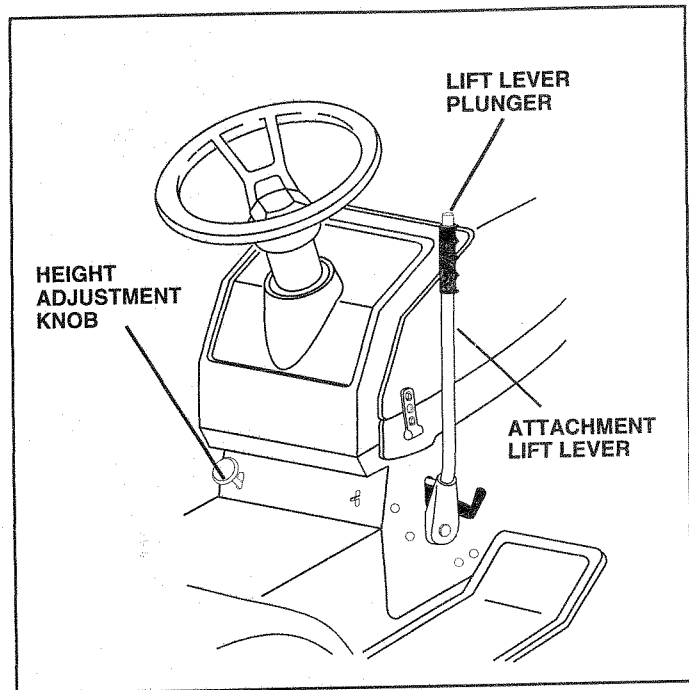

FIG. 6

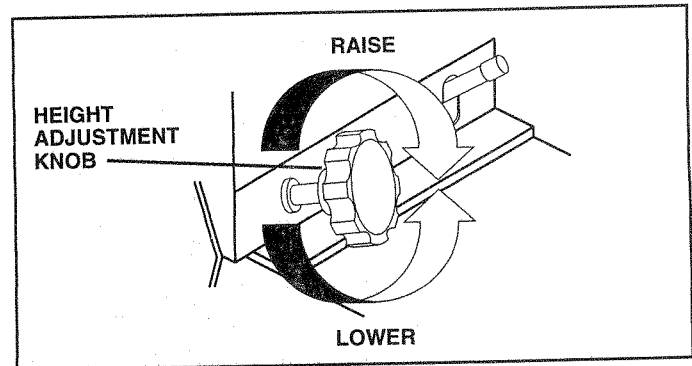

FIG. 7

CHECK DECK LEVELNESS

For best cutting results, mower housing should be properly leveled. See "TO LEVEL MOWER HOUSING" in the Service and Adjustments section of this manual.

CHECK FOR PROPER POSITION OF ALL BELTS

See the figures that are shown for replacing motion, mower drive, and mower blade drive belts in the Service and Adjustments section of this manual. Verify that the belts are routed correctly.

CHECK BRAKE SYSTEM

After you learn how to operate your tractor, check to see that the brake is properly adjusted. See "TO ADJUST BRAKE" in the Service and Adjustments section of this manual.

ASSEMBLY

INSTALL BATTERY (See Figs. 8 & 9)



CAUTION: Do not short battery terminals. Before installing battery, remove metal bracelets, wristwatch bands, rings, etc.

Positive terminal must be connected first to prevent sparking from accidental grounding.

- Lift hood to raised position.
- Lower battery into battery tray with terminals to rear of tractor.
- Be sure battery drain tube has not come loose and is securely attached to drain in battery tray.
- First connect RED battery cable to positive (+) battery terminal with hex bolt, flat washer, lock washer and hex nut as shown. Tighten securely.
- Connect BLACK grounding cable to negative (-) battery terminal with remaining hex bolt, flat washer, lock washer and hex nut. Tighten securely.
- Place terminal guard onto the battery, covering the terminals.
- Slide one (1) 1" washer onto battery bolt. Slide bolt up through key hole, through terminal guard and thread wing nut onto bolt. Do not tighten.
- Repeat for opposite side.
- Tighten wing nuts while making sure the square shafts of the bolts are into the slots of keyholes. By hand only, tighten securely.
- Be sure terminal access doors are closed.

Use terminal access doors for:

- Inspection for secure connections (to tighten hardware).
- Inspection for corrosion.
- Testing battery.
- Periodic charging .

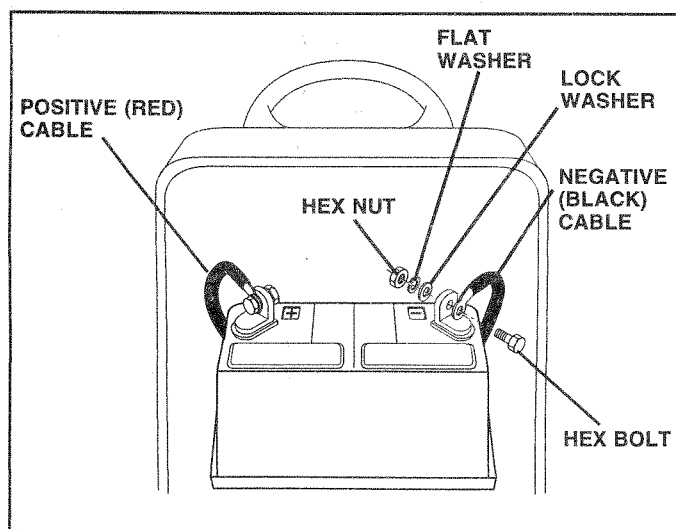

FIG. 8

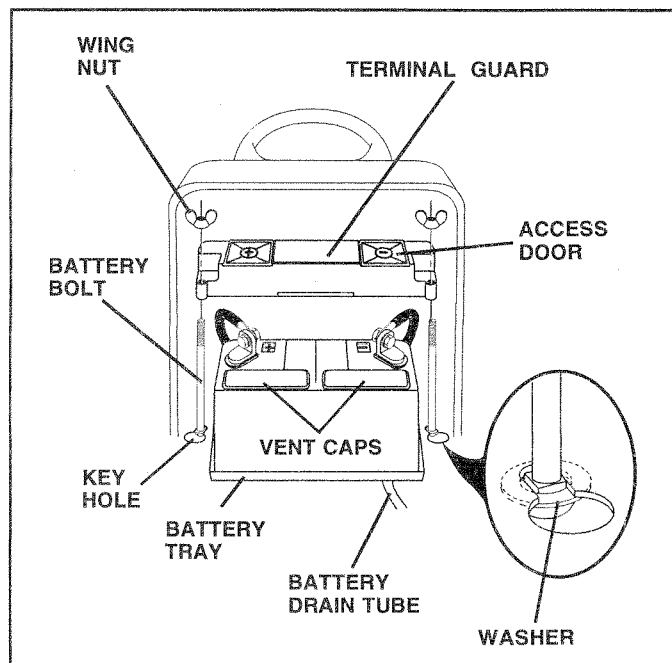

FIG. 9

✓ CHECKLIST

BEFORE YOU OPERATE AND ENJOY YOUR NEW TRACTOR, WE WISH TO ASSURE THAT YOU RECEIVE THE BEST PERFORMANCE AND SATISFACTION FROM THIS QUALITY PRODUCT.

PLEASE REVIEW THE FOLLOWING CHECKLIST:

- ✓ All assembly instructions have been completed.
- ✓ No remaining loose parts in carton.
- ✓ Battery is properly prepared and charged. (Minimum 1 hour at 6 amps).
- ✓ Seat is adjusted comfortably and tightened securely.
- ✓ All tires are properly inflated. (For shipping purposes, the tires were overinflated at the factory).
- ✓ Be sure mower deck is properly leveled side-to-side/front-to-rear for best cutting results. (Tires must be properly inflated for leveling)
- ✓ Check mower and drive belts. Be sure they are routed properly around pulleys and inside all belt keepers.
- ✓ Check wiring. See that all connections are still secure and wires are properly clamped.

WHILE LEARNING HOW TO USE YOUR TRACTOR, PAY EXTRA ATTENTION TO THE FOLLOWING IMPORTANT ITEMS:

- ✓ Engine oil is at proper level.
- ✓ Fuel tank is filled with fresh, clean, regular unleaded gasoline.
- ✓ Become familiar with all controls - their location and function. Operate them before you start the engine.
- ✓ Be sure brake system is in safe operating condition.

OPERATION

KNOW YOUR TRACTOR

READ THIS OWNER'S MANUAL AND SAFETY RULES BEFORE OPERATING YOUR TRACTOR

Compare the illustrations with your tractor to familiarize yourself with the location of various controls and adjustments. Save this manual for future reference.

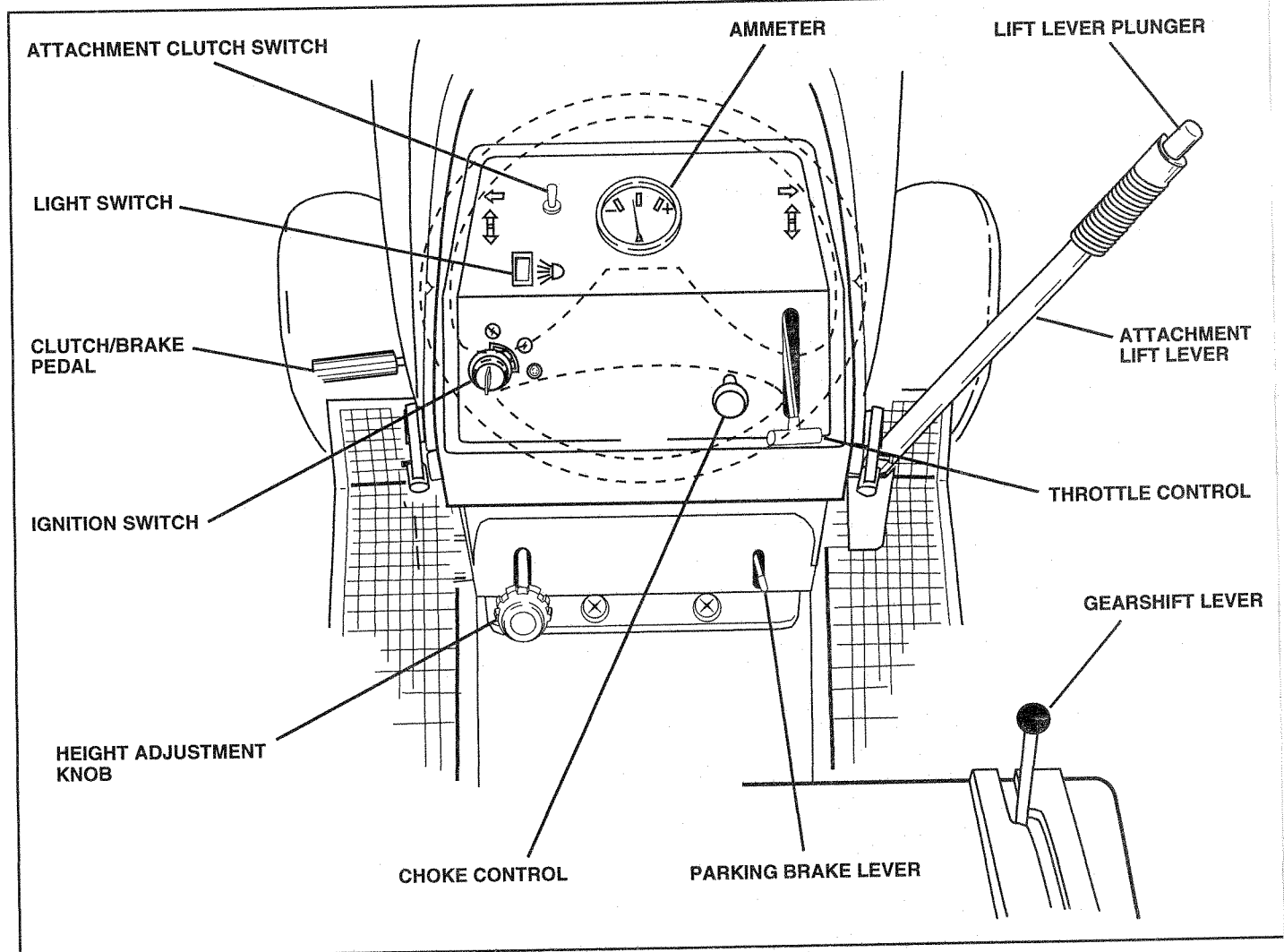

FIG. 10

Your tractor conforms to the safety standards of the American National Standards Institute.

ATTACHMENT CLUTCH SWITCH - Used to engage mower blades or other attachments mounted to your tractor.

ATTACHMENT LIFT LEVER - Used to raise and lower mower deck or other attachments mounted to your tractor.

CLUTCH/BRAKE PEDAL - Used for declutching and braking the tractor and starting the engine.

HEIGHT ADJUSTMENT KNOB - Used to adjust the mower height.

LIFT LEVER PLUNGER - Used to release attachment lift lever when changing its position.

GEARSHIFT LEVER - Selects the speed and direction of the tractor.

IGNITION SWITCH - Used to start and stop the engine.

LIGHT SWITCH - Turns the headlights on and off.

PARKING BRAKE LEVER - Locks clutch/brake pedal into the brake position.

THROTTLE CONTROL - Used to control engine speed.

CHOKE CONTROL - Used when starting a cold engine.

AMMETER - Indicates charging (+) or discharging (-) of battery.

OPERATION



The operation of any tractor can result in foreign objects thrown into the eyes, which can result in severe eye damage. Always wear safety glasses or eye shields before starting your tractor and while moving. We recommend wide vision safety mask for over the spectacles or standard safety glasses.

HOW TO USE YOUR TRACTOR SET PARKING BRAKE (See Fig. 11)

Depress clutch/brake pedal into full "BRAKE" position and hold.

Place parking brake lever in "ENGAGED" position and release pressure from clutch/brake pedal. Pedal should remain in "BRAKE" position. Make sure parking brake will hold tractor secure.

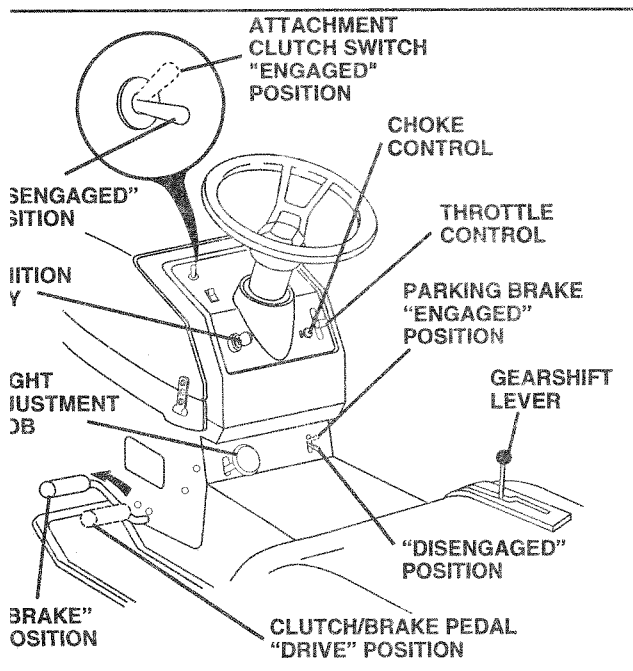

FIG. 11

STOPPING (See Fig. 11)

LOWER BLADES -

Move attachment clutch switch to "DISENGAGED" position.

STOP DRIVE -

Depress clutch/brake pedal into full "BRAKE" position.

Move gear shift lever to "NEUTRAL" position.

STOP ENGINE -

Move throttle control to "STOP" position.

NOTE: Failure to move throttle control to "STOP" position allowing engine to idle before stopping may cause engine to "backfire".

Turn ignition key to "OFF" position and remove key. Always remove key when leaving tractor to prevent unauthorized use.

Never use choke to stop engine.

NOTE: Under certain conditions when unit is standing idle with the engine running, hot engine exhaust gases may cause "browning" of grass. To eliminate this possibility, always stop engine when stopping tractor on grass areas.



CAUTION: Always stop tractor completely, as described above, before leaving the operator's position; to empty grass catcher, etc.

HOW TO USE CHOKE CONTROL (See Fig. 11)

Use choke control whenever you are starting a cold engine. Do not use to start a warm engine.

- To engage choke control, pull knob out. Slowly push knob in to disengage.

HOW TO USE THROTTLE CONTROL (See Fig. 11)

Always operate engine at full throttle.

- Operating engine at less than full throttle reduces the battery charging rate.
- Full throttle offers the best mower performance.

HOW TO MOVE FORWARD AND BACKWARD (See Fig. 11)

The direction and speed of movement is controlled by the gearshift lever.

- Start tractor with clutch/brake pedal depressed and gearshift lever in "NEUTRAL" position.
- Move gearshift lever to desired position.
- Slowly release clutch/brake pedal to start movement.

IMPORTANT: BRING TRACTOR TO A COMPLETE STOP BEFORE SHIFTING OR CHANGING GEARS. FAILURE TO DO SO WILL SHORTEN THE USEFUL LIFE OF YOUR TRANSAXLE.

HOW TO ADJUST MOWER CUTTING HEIGHT (See Fig. 11)

The cutting height is controlled by turning the height adjustment knob in desired direction.

- Turn knob clockwise (↻) to raise cutting height.
- Turn knob counterclockwise (↺) to lower cutting height.

The cutting height range is approximately 1-1/4" to 3-3/4". The heights are measured from the ground to the blade tip with the engine not running. These heights are approximate and may vary depending upon soil conditions, height of grass and types of grass being mowed.

- The average lawn should be cut to approximately 2-1/2 inches during the cool season and to over 3 inches during hot months. For healthier and better looking lawns, mow often and after moderate growth.
- For best cutting performance, grass over 6 inches in height should be mowed twice. Make the first cut relatively high; the second to desired height.

OPERATION

TO OPERATE MOWER (See Figs. 10 and 11)

Your unit is equipped with an operator presence sensing switch. Any attempt by the operator to leave the seat with the engine running and the mower clutch engaged will shut off the engine.

- Select desired height of cut.
- Lower mower with attachment lift control.
- Start mower blades by engaging attachment clutch control.
- TO STOP MOWER BLADES - disengage attachment clutch control.



CAUTION: Do not operate the mower without either the entire grass catcher, on mowers so equipped, or the discharge guard in place.

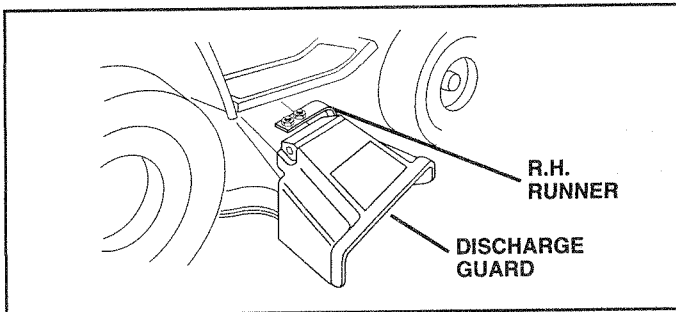

FIG. 12

TO OPERATE ON HILLS



CAUTION: Do not drive up or down hills with slopes greater than 15° and do not drive across any slope.

- Choose the slowest speed before starting up or down hills.
- Avoid stopping or changing speed on hills.
- If slowing is necessary, move throttle control to slower position.
- If stopping is absolutely necessary, push clutch/brake pedal quickly to brake position and engage parking brake.
- Move gearshift lever to "NEUTRAL" position.
- To restart movement, move gearshift lever to 1st gear. Be sure you have allowed room for tractor to roll slightly as you restart movement.
- Slowly release parking brake and clutch/brake pedal.
- Make all turns slowly.

TO TRANSPORT

- Raise attachment lift control to highest position.
- When pushing or towing your tractor, be sure gearshift lever is in "NEUTRAL" position.
- Do not push or tow tractor at more than five (5) MPH.

NOTE: To protect hood from damage when transporting your tractor on a truck or a trailer, be sure hood is closed and secured to tractor. Use an appropriate means of tying hood to tractor (rope, cord, etc.).

BEFORE STARTING THE ENGINE

CHECK ENGINE OIL LEVEL (See Fig. 13)

- The engine in your unit has been shipped, from the factory, already filled with summer weight oil.
- Check engine oil with unit on level ground.
- Remove oil fill cap/dipstick and wipe clean, reinsert the dipstick and screw cap tight, wait for a few seconds, remove and read oil level. If necessary, add oil until "FULL" mark on dipstick is reached. Do not overfill.
- For cold weather operation you should change oil for easier starting (See "OIL VISCOSITY CHART" in the Customer Responsibilities section of this manual).
- To change engine oil, see the Customer Responsibilities section in this manual.

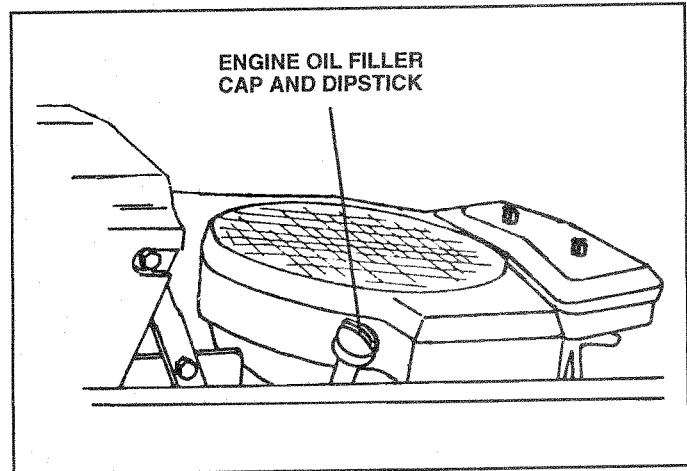

FIG. 13

OPERATION

ADD GASOLINE

- Fill fuel tank. Use fresh, clean, regular unleaded gasoline. (Use of leaded gasoline will increase carbon and lead oxide deposits and reduce valve life).

IMPORTANT: WHEN OPERATING IN TEMPERATURES BELOW 32°F(0°C), USE FRESH, CLEAN WINTER GRADE GASOLINE TO HELP INSURE GOOD COLD WEATHER STARTING.

WARNING: Experience indicates that alcohol blended fuels (called gasohol or using ethanol or methanol) can attract moisture which leads to separation and formation of acids during storage. Acidic gas can damage the fuel system of an engine while in storage. To avoid engine problems, the fuel system should be emptied before storage of 30 days or longer. Drain the gas tank, start the engine and let it run until the fuel lines and carburetor are empty. Use fresh fuel next season. See Storage Instructions for additional information. Never use engine or carburetor cleaner products in the fuel tank or permanent damage may occur.



CAUTION: Fill to bottom of gas tank filler neck. Do not overfill. Wipe off any spilled oil or fuel. Do not store, spill or use gasoline near an open flame.

TO START ENGINE (See Fig. 11)

When starting engine for the first time or if engine has run out of fuel, it will take extra cranking time to move fuel from the tank to the engine.

- Depress the clutch/brake pedal and set the parking brake.
- Place gearshift lever in "NEUTRAL" position.
- Move attachment clutch to "DISENGAGED" position.
- Pull choke control out to "CHOKE" position for cold engine start. For warm engine start do not use choke control.
- Move throttle control to midway between "FAST" and "SLOW" positions.
- Turn ignition key clockwise to "START" position and release key as soon as engine starts. Do not run starter continuously for more than fifteen seconds per minute. If engine does not start after several attempts, move throttle control to "FAST" position, wait a few minutes and try again.
- When engine starts, slowly push choke control in.
- Move throttle control to "FAST" position.
- Allow engine to warm up for a few minutes before engaging clutch/brake pedal or attachment clutch switch.

NOTE: If at a high altitude (above 3000 feet) or in cold temperatures (below 32° F), the carburetor fuel mixture may need to be adjusted for best engine performance. See "TO ADJUST CARBURETOR" in the Service and Adjustments section of this manual.



CAUTION: Before driving the tractor, install mower or remove front mower suspension bracket and suspension arms.

MOWING TIPS

- Tire chains cannot be used when the mower housing is attached to tractor.
- Mower should be properly leveled for best mowing performance. See "TO LEVEL MOWER HOUSING" in the Service and Adjustments section of this manual.
- Use the runner on the right hand side of mower as a guide. The blade cuts approximately an inch outside the runner (See Fig. 12).
- The left hand side of mower should be used for trimming.
- Drive so that clippings are discharged onto the area that has been cut. Have the cut area to the right of the tractor. This will result in a more even distribution of clippings and more uniform cutting.
- When mowing large areas, start by turning to the right so that clippings will discharge away from shrubs, fences, driveways, etc. After one or two rounds, mow in the opposite direction making left hand turns until finished (See Fig. 14).
- If grass is extremely tall, it should be mowed twice to reduce load and possible fire hazard from dried clippings. Make first cut relatively high; the second to the desired height.
- Do not mow grass when it is wet. Wet grass will plug mower and leave undesirable clumps. Allow grass to dry before mowing.
- Always operate engine at full throttle when mowing to assure better mowing performance and proper discharge of material. Regulate ground speed by selecting a low enough gear to give the mower cutting performance as well as the quality of cut desired.
- When operating attachments, select a ground speed that will suit the terrain and give best performance of the attachment being used.

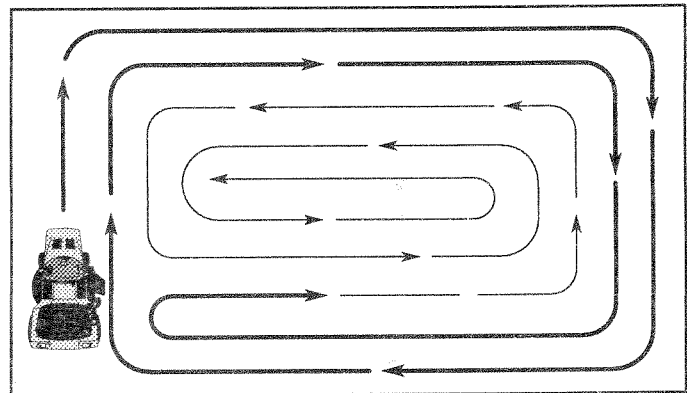

FIG. 14

CUSTOMER RESPONSIBILITIES

MAINTENANCE SCHEDULE FILL IN DATES AS YOU COMPLETE REGULAR SERVICE		SERVICE DATES						
		BEFORE EACH USE	FIRST 2 HOURS	EVERY 8 HOURS	EVERY 25 HOURS	EVERY 50 HOURS	EVERY 100 HOURS	BEFORE STORAGE
TRACTOR	Check Brake Operation	✓	✓					
	Check Tire Pressure	✓	✓					
	Check for Loose Fasteners	✓					✓	
	Sharpen/Replace Mower Blades			✓ ₄				
	Lubrication Chart			✓			✓	
	Check Battery Level/Recharge			✓				
	Clean Battery and Terminals			✓			✓	
	Check Transmission Cooling			✓				
	Adjust Blade Belt(s) Tension					✓ ₅		
	Adjust Motion Drive Belt(s) Tension					✓ ₅		
ENGINE	Check Engine Oil Level	✓	✓					
	Change Engine Oil		✓	✓ _{1,2,3}			✓	
	Clean Air Filter			✓ ₂				
	Clean Air Screen			✓ ₂				
	Inspect Muffler/Spark Arrester				✓			
	Replace Oil Filter (If equipped)					✓ _{1,2}		
	Clean Engine Cooling Fins					✓ ₂		
	Replace Spark Plug					✓	✓	
	Replace Air Filter Paper Cartridge					✓ ₂		
Replace Fuel Filter						✓		

1 - Change more often when operating under a heavy load or in high ambient temperatures.
2 - Service more often when operating in dirty or dusty conditions.

3 - If equipped with oil filter, change oil every 50 hours.
4 - Replace blades more often when mowing in sandy soil.
5 - If equipped with adjustable system.

GENERAL RECOMMENDATIONS

The warranty on this tractor does not cover items that have been subjected to operator abuse or negligence. To receive full value from the warranty, operator must maintain tractor as instructed in this manual.

Some adjustments will need to be made periodically to properly maintain your tractor.

All adjustments in the Service and Adjustments section of this manual should be checked at least once each season.

- Once a year you should replace the spark plug, clean or replace air filter, and check blades and belts for wear. A new spark plug and clean air filter assure proper air-fuel mixture and help your engine run better and last longer.

BEFORE EACH USE

- Check engine oil level.
- Check brake operation.
- Check tire pressure.
- Check for loose fasteners.

LUBRICATION CHART

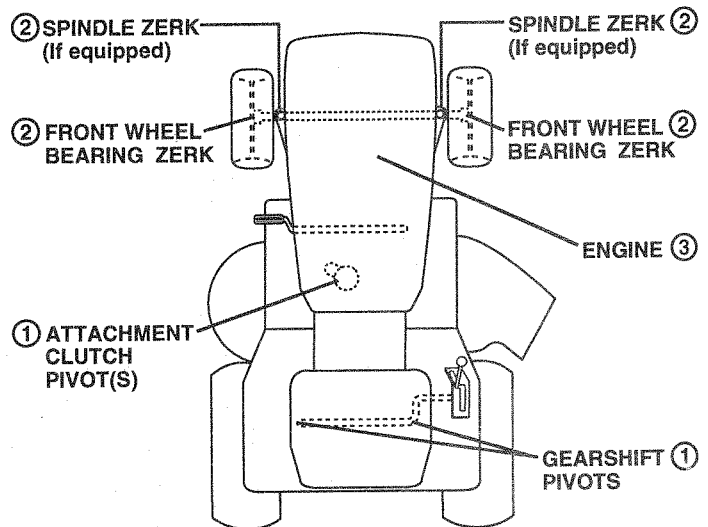

① SAE 30 OR 10W30 MOTOR OIL API - SG

② GENERAL PURPOSE GREASE

③ REFER TO CUSTOMER RESPONSIBILITIES "ENGINE" SECTION

IMPORTANT: DO NOT OIL OR GREASE THE PIVOT POINTS WHICH HAVE SPECIAL NYLON BEARINGS. VISCOUS LUBRICANTS WILL ATTRACT DUST AND DIRT THAT WILL SHORTEN THE LIFE OF THE SELF-LUBRICATING BEARINGS. IF YOU FEEL THEY MUST BE LUBRICATED, USE ONLY A DRY, POWDERED GRAPHITE TYPE LUBRICANT SPARINGLY.

CUSTOMER RESPONSIBILITIES

TRACTOR

Always observe safety rules when performing any maintenance.

BRAKE OPERATION

If tractor requires more than six (6) feet stopping distance at high speed in highest gear, than brake must be adjusted. (See "TO ADJUST BRAKE" in the Service and Adjustments section of this manual).

TIRES

- Maintain proper air pressure in all tires (See "PRODUCT SPECIFICATIONS" on page 3 of this manual).
- Keep tires free of gasoline, oil, or insect control chemicals which can harm rubber.
- Avoid stumps, stones, deep ruts, sharp objects and other hazards that may cause tire damage.

BLADE CARE

For best results mower blades must be kept sharp. Replace bent or damaged blades.

BLADE REMOVAL (See Fig. 15)

- Raise mower to highest position to allow access to blades.
- Remove hex bolt, lock washer and flat washer securing blade.
- Install new or resharpened blade with trailing edge up towards deck as shown.
- Reassemble hex bolt, lock washer and flat washer in exact order as shown.
- Tighten bolt securely (30-35 Ft. Lbs. torque).

IMPORTANT: BLADE BOLT IS GRADE 5 HEAT TREATED.

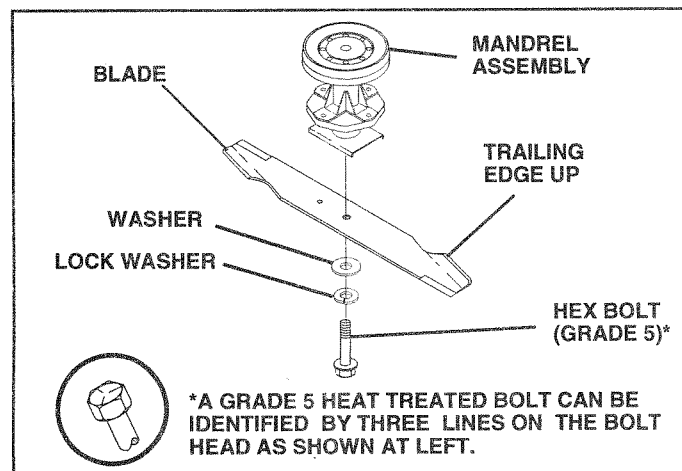

FIG. 15

TO SHARPEN BLADE (See Fig. 16)

Care should be taken to keep the blade balanced. An unbalanced blade will cause excessive vibration and eventual damage to mower and engine.

- The blade can be sharpened with a file or on a grinding wheel. Do not attempt to sharpen while on the mower.
- To check blade balance, drive a nail into a beam or wall. Leave about one inch of the straight nail exposed. Place center hole of blade over the head of the nail. If blade is balanced, it should remain in a horizontal position. If either end of the blade moves downward, sharpen the heavy end until the blade is balanced.

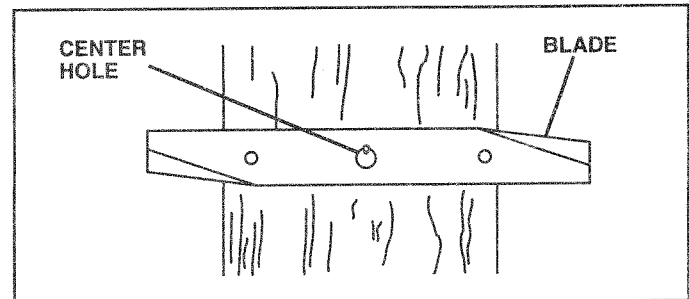

FIG. 16

BATTERY (See Fig. 17)

Your tractor has a battery charging system which is sufficient for normal use. However, periodic charging of the battery with an automotive charger will extend its life.

- Acid solution level in each battery cell should be even with bottoms of vent wells. Add only distilled or iron free water if necessary. Do not overfill.
- Keep battery and terminals clean.
- Keep battery bolts tight.
- Keep vent caps tight and small vent holes in caps open.
- Recharge at 6 amperes for 1 hour.

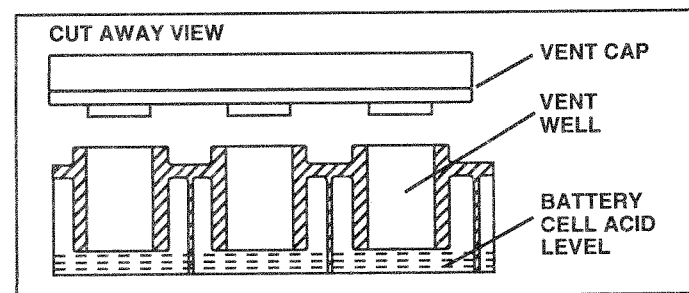

FIG. 17

CUSTOMER RESPONSIBILITIES

TO CLEAN BATTERY AND TERMINALS -

Corrosion and dirt on the battery and terminals can cause the battery to "leak" power.

- Remove terminal guard.
- Disconnect BLACK battery cable first, then RED battery cable and remove battery from tractor.
- Wash battery with solution of four tablespoons of baking soda to one gallon of water. Be careful not to get the soda solution into the cells.
- Rinse the battery with plain water and dry.
- Clean terminals and battery cable ends with wire brush until bright.
- Coat terminals with grease or petroleum jelly.
- Reinstall battery (See "INSTALL BATTERY" in the Assembly section of this manual).

V-BELTS

Check V-Belts for deterioration and wear after 100 hours and replace if necessary. The mower blade drive and motion drive belts are not adjustable. Replace belts if they begin to slip from wear.

TRANSAXLE COOLING

Keep transaxle free from build-up of dirt and chaff which can restrict cooling.

ENGINE

LUBRICATION

Only use high quality detergent oil rated with API service classification SG. Select the oil's SAE viscosity grade according to your expected operating temperature.

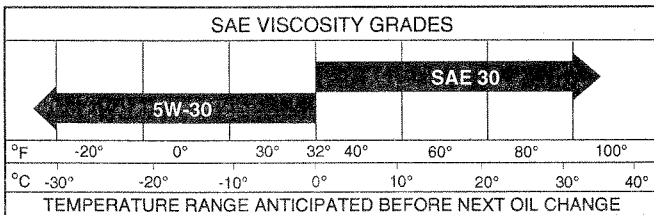

NOTE: Although multi-viscosity oils (5W30, 10W30, etc.) improve starting in cold weather, these multi-viscosity oils will result in increased oil consumption when used above 32° F. Check your engine oil level more frequently to avoid possible engine damage from running low on oil.

Change the oil after the first two hours of operation and every 25 hours thereafter or at least once a year if the tractor is not used for 25 hours in one year.

Check the crankcase oil level before starting the engine and after each eight (8) hours of continuous use. Tighten oil fill cap/dipstick securely each time you check the oil level.

TO CHANGE ENGINE OIL (See Fig. 18)

Determine temperature range expected before oil change. All oil must meet API service classification SG.

- Be sure tractor is on level surface.
- Oil will drain more freely when warm.
- Catch oil in a suitable container.
- Remove oil fill cap/dipstick. Be careful not to allow dirt to enter the engine when changing oil.
- Remove drain plug.
- After oil has drained completely, replace oil drain plug and tighten securely.
- Refill engine with oil through oil fill dipstick tube. Pour slowly. Do not overfill. For approximate capacity see "PRODUCT SPECIFICATIONS" on page 3 of this manual.
- Use gauge on dipstick for checking level. Be sure dipstick cap is tightened securely for accurate reading. Keep oil at "FULL" line on dipstick.

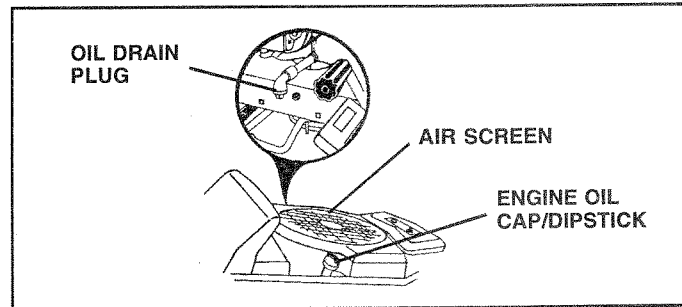

FIG. 18

CLEAN AIR SCREEN (See Fig. 18)

The air screen must be kept free of dirt and chaff to prevent engine damage from overheating. Clean with a wire brush or compressed air to remove dirt and stubborn dried gum fibers.

CLEAN ENGINE COOLING FINS (See Fig. 19)

Remove any dust, dirt or oil from engine cooling fins to prevent engine damage from overheating. Air guide covers must be removed. Remove side panels and hood (See "TO REMOVE HOOD AND GRILL ASSEMBLY" in the Service and Adjustments section of this manual).

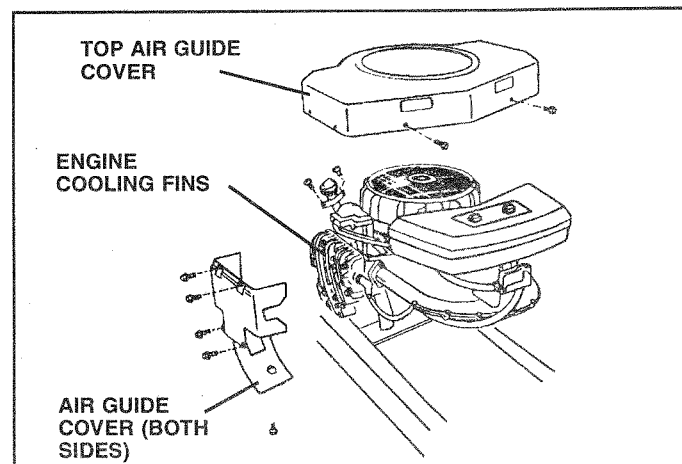

FIG. 19

CUSTOMER RESPONSIBILITIES

AIR FILTER (See Fig. 20)

Your engine will not run properly using a dirty air filter. Clean the foam pre-cleaner element after every 25 hours of operation or every season. Service paper cartridge every 100 hours or every season, whichever occurs first.

Service air cleaner more often under dusty conditions.

- Remove knob(s) and cover.

TO SERVICE PRE-CLEANER

- Slide foam pre-cleaner off cartridge.
- Wash it in liquid detergent and water.
- Squeeze it dry in a clean cloth.
- Saturate it in engine oil. Wrap it in clean, absorbent cloth and squeeze to remove excess oil.
- Reinstall pre-cleaner over cartridge.
- Reinstall cover and secure with knob(s).

TO SERVICE CARTRIDGE

- Remove wing nuts and cartridge plate.
- Remove cartridge and clean by tapping gently on flat surface.
- If very dirty, replace or wash in a nonsudsing detergent and warm water solution. Rinse thoroughly with water from inside out until water runs clear. Let cartridge dry thoroughly before using.
- Reinstall cartridge plate, wing nuts, pre-cleaner, cover and secure with knob(s).

IMPORTANT: PETROLEUM SOLVENTS, SUCH AS KEROSENE, ARE NOT TO BE USED TO CLEAN THE CARTRIDGE. THEY MAY CAUSE DETERIORATION OF THE CARTRIDGE. DO NOT OIL CARTRIDGE. DO NOT USE PRESSURIZED AIR TO CLEAN OR DRY CARTRIDGE.

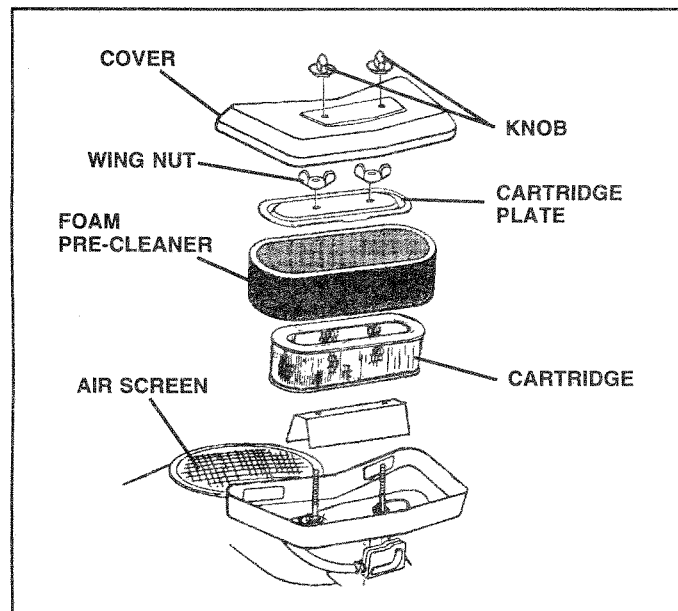

FIG. 20

MUFFLER

Inspect and replace corroded muffler and spark arrester (if equipped) as it could create a fire hazard and/or damage.

SPARK PLUGS

Replace spark plugs at the beginning of each mowing season or after every 100 hours of operation, whichever comes first. Spark plug type and gap setting are shown in "PRODUCT SPECIFICATIONS" on page 3 of this manual.

IN-LINE FUEL FILTER (See Fig. 21)

The fuel filter should be replaced once each season. If fuel filter becomes clogged, obstructing fuel flow to carburetor, replacement is required.

- With engine cool, remove filter and plug fuel line sections.
- Place new fuel filter in position in fuel line with arrow pointing towards carburetor.
- Be sure there are no fuel line leaks and clamps are properly positioned.
- Immediately wipe up any spilled gasoline.

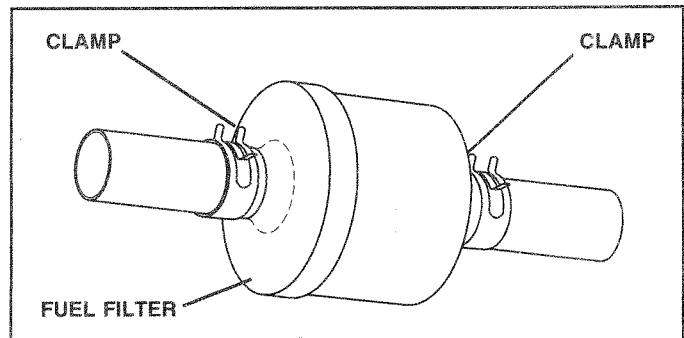

FIG. 21

CLEANING

- Clean engine, battery, seat, finish, etc. of all foreign matter.
- Keep finished surfaces and wheels free of all gasoline, oil, etc.
- Protect painted surfaces with automotive type wax.

We do not recommend using a garden hose to clean your tractor unless the electrical system, muffler, air filter and carburetor are covered to keep water out. Water in engine can result in a shortened engine life.

SERVICE AND ADJUSTMENTS

CAUTION: BEFORE PERFORMING ANY SERVICE OR ADJUSTMENTS:



- Depress clutch/brake pedal fully and set parking brake.
- Place gearshift lever in "NEUTRAL" position.
- Place attachment clutch in "DISENGAGED" position.
- Turn ignition key "OFF" and remove key.
- Make sure the blades and all moving parts have completely stopped.
- Disconnect spark plug wire from spark plug and place wire where it cannot come in contact with plug.

TRACTOR

TO REMOVE MOWER (See Fig. 22)

Mower will be easier to remove from the right side of tractor.

- Remove mower drive belt from electric clutch pulley only (See "TO REPLACE MOWER DRIVE BELT" through step removing belt from electric clutch pulley).
- Pull retainer springs out of rear suspension trunnions. Remove rear suspension trunnions from lift brackets.
- Pull retainer springs from front hinge pins.
- Remove hinge pins attaching parallel link to mower and front axle.
- Raise lift lever to raise suspension arms. Slide mower out from under tractor.

IMPORTANT: IF AN ATTACHMENT OTHER THAN THE MOWER DECK IS TO BE MOUNTED ON THE TRACTOR, REMOVE THE L.H. AND R.H. SUSPENSION ARMS AND THE FRONT SUSPENSION BRACKET.

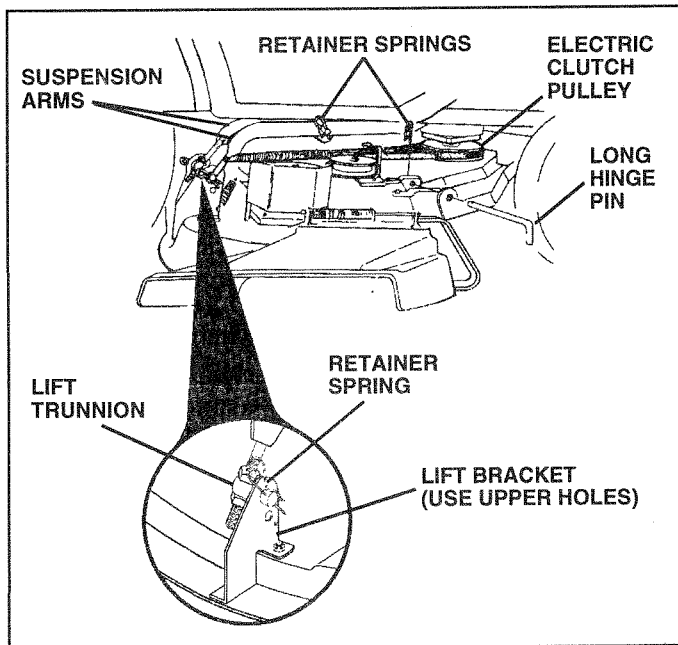

FIG. 22

TO INSTALL MOWER

See "INSTALL MOWER" in the Assembly section of this manual.

TO LEVEL MOWER HOUSING

Adjust the mower while tractor is parked on level ground or driveway. Make sure tires are properly inflated (See "PRODUCT SPECIFICATIONS" on page 3). If tires are over or underinflated, you will not properly adjust your mower.

SIDE-TO-SIDE ADJUSTMENT (See Figs. 23 and 24)

- Raise attachment lift lever to its highest position.
- Measure height from bottom deck curl to ground level at front corners of mower. Distance "A" should be the same.
- If distance "A" needs to be changed, snap out access hole cover on left side of tractor above footrest.
- To raise left side of mower, loosen nut "B" and tighten nut "C".
- To lower left side of mower, loosen nut "C" and tighten nut "B".
- When distance "A" is equal, securely tighten nuts "B" and "C".
- Replace access hole cover.

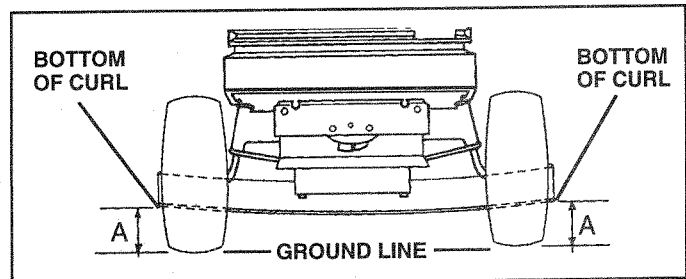

FIG. 23

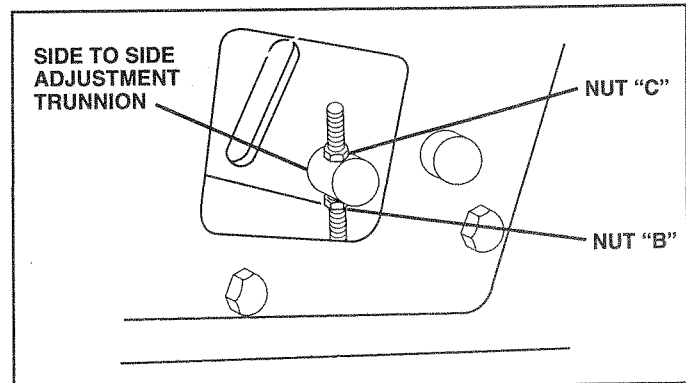

FIG. 24

SERVICE AND ADJUSTMENTS

FRONT-TO-BACK ADJUSTMENT (See Figs. 25 and 26)

To obtain the best cutting results, the mower housing should be adjusted so the back is approximately 7/8" to 1-1/8" higher than the front when the mower is in height adjustment position.

Measure distance "D" from ground line to bottom of deck curl at centerline outside of mandrels.

- To raise rear of mower, loosen nut "E" on both rear suspension arms. Screw both nuts "F" on both rear suspension arms an equal number of turns.
- When distance "D" is 7/8" to 1-1/8" higher at rear than front, retighten nuts "E".
- Recheck side-to-side adjustment.

IMPORTANT: WHEN ADJUSTING REAR SUSPENSION ARMS, ALWAYS ADJUST BOTH EQUALLY SO MOWER WILL STAY LEVEL SIDE-TO-SIDE.

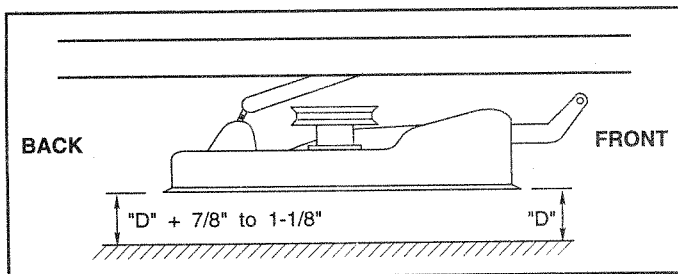

FIG. 25

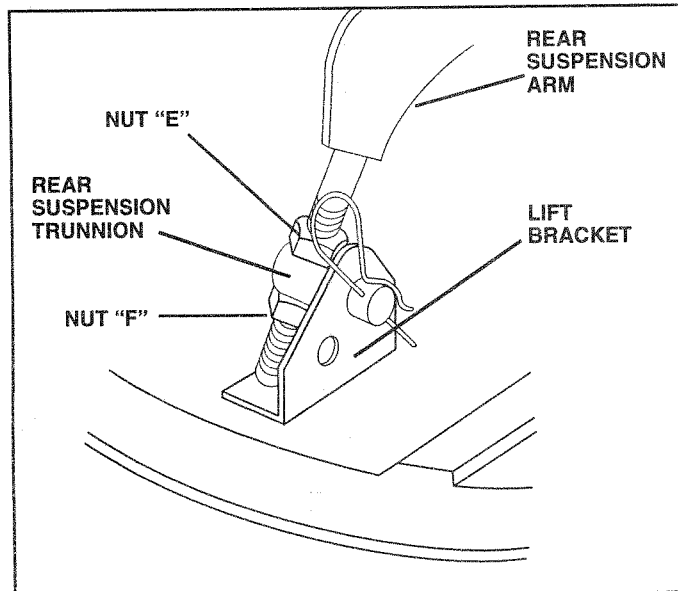

FIG. 26

TO ADJUST ATTACHMENT CLUTCH (See Fig. 27)

The electric clutch should provide years of service. The clutch has a built-in brake that stops the pulley within 5 seconds. Eventually, the internal brake will wear so the mower blades will not stop as recommended. Adjustments should be made by authorized service technician.

- Make sure attachment clutch and ignition switches are in the "OFF" position.
- Adjust the three nylon locknuts until the space between clutch plate and rotor measures .012 inches at all three slot locations cut in side of brake plate.

NOTE: After installing a new electric clutch, run tractor at full throttle, and engage and disengage electric clutch 10 cycles to wear in clutch plate.

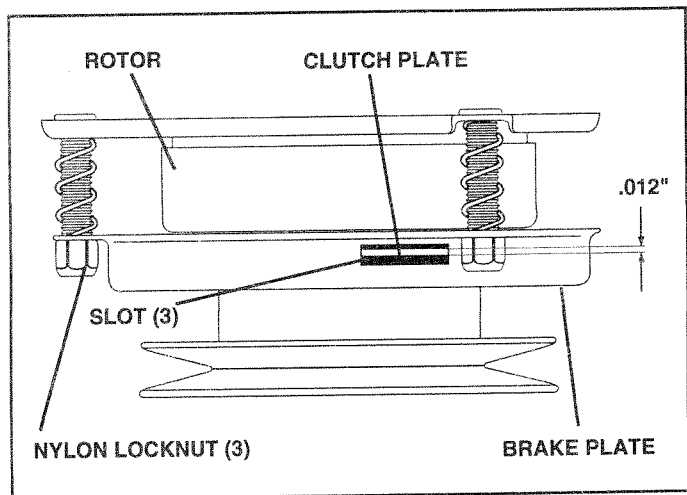

FIG. 27

SERVICE AND ADJUSTMENTS

TO REPLACE MOWER DRIVE BELT (See Figs. 28 and 29)

Park the tractor on level surface. Engage parking brake.
BELT REMOVAL -

- Place attachment clutch in "DISENGAGED" position.
- Turn height adjustment knob to lowest setting.
- Move attachment lift lever forward to lower mower to its lowest position.
- Roll belt off electric clutch pulley.
- Pull belt off mower pulley and both idler pulleys.

BELT INSTALLATION -

- Place belt around mower pulley and both idler pulleys.
- Roll belt over electric clutch pulley.
- Make sure belt is in all pulley grooves and inside all belt guides.

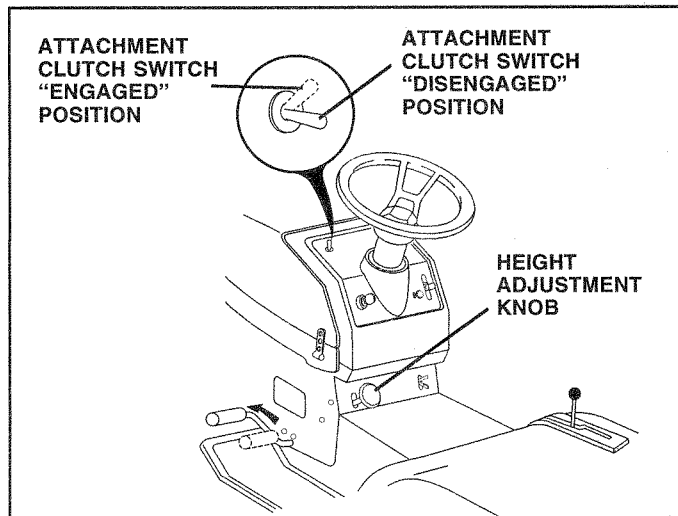

FIG. 28

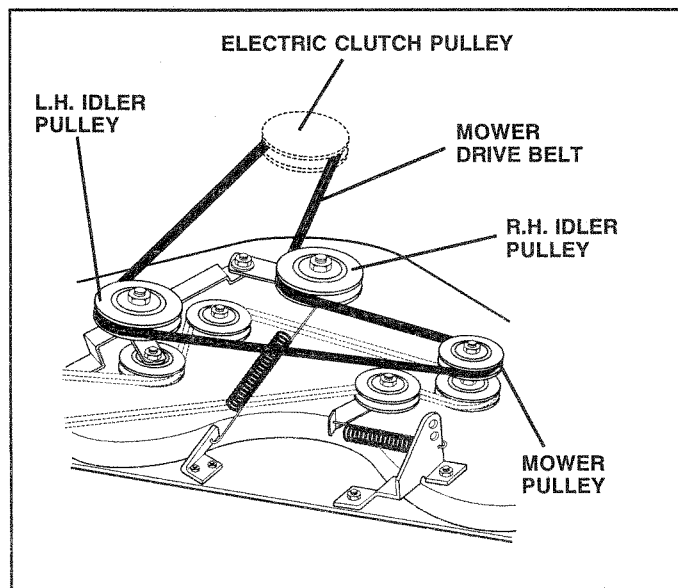

FIG. 29

TO ADJUST BRAKE (See Fig. 30)

Your tractor is equipped with an adjustable brake system which is mounted on the right side of the transaxle.

If tractor requires more than six (6) feet stopping distance at high speed in highest gear, then brake must be adjusted.

- Depress clutch/brake pedal and engage parking brake.
- Measure distance between brake operating arm and nut "A" on brake rod.
- If distance is other than 1-1/2", disengage parking brake, loosen jam nut and turn nut "A" until distance becomes 1-1/2". Retighten jam nut against nut "A".
- Engage parking brake and recheck distance.
- Road test tractor for proper stopping distance as stated above. Readjust if necessary. If stopping distance is still greater than six (6) feet in highest gear, further maintenance is necessary. Contact your nearest authorized service center.

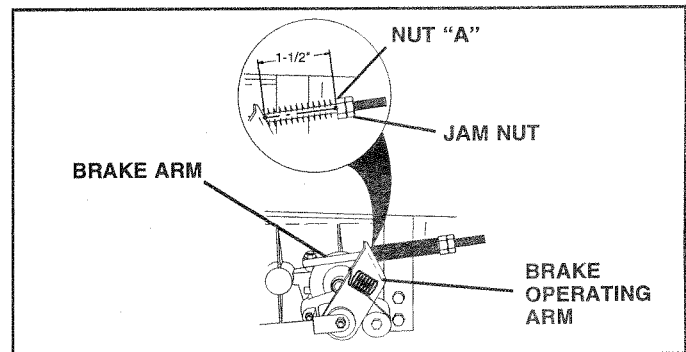

FIG. 30

TO REPLACE MOWER BLADE DRIVE BELT (See Fig. 31)

- Remove mower (See "TO REMOVE MOWER" in this section of this manual).
- Remove mower drive belt (See "TO REPLACE MOWER DRIVE BELT" in this section of this manual).
- Pull mower blade drive belt towards rear of mower at tensioning pulley. Place a block between tensioning pulley and mower lift bracket. Roll belt off tensioning pulley.
- Roll belt off all other pulleys.
- Slide belt from under spring.
- To install belt, reverse above procedure. Make sure belt is engaged in all pulleys.

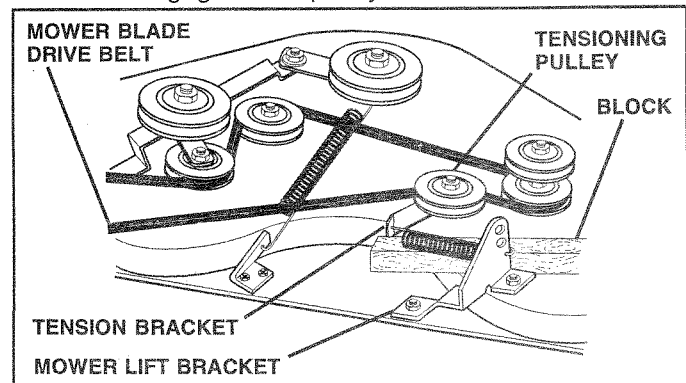

FIG. 31

SERVICE AND ADJUSTMENTS

TO REPLACE MOTION DRIVE BELT (See Fig. 32)

Park the tractor on level surface. Engage parking brake. For assistance, there is a belt installation guide decal on bottom side of left footrest.

- Remove mower (See "TO REMOVE MOWER" in this section of this manual.)
- Disconnect clutch wire harness.
- Remove clutch locator.
- Remove upper belt keeper.
- Remove belt from stationary idler and clutching idler.
- Pull belt slack toward rear of tractor. Remove belt upwards from transaxle pulley by deflecting belt keepers.
- Pull belt toward front of tractor and remove downwards from around electric clutch.
- Install new belt by reversing above procedure.

IMPORTANT: MAKE SURE UPPER BELT KEEPER IS POSITIONED PROPERLY BETWEEN LOCATOR TABS AND ELECTRIC CLUTCH WIRE CONNECTION IS SECURE.

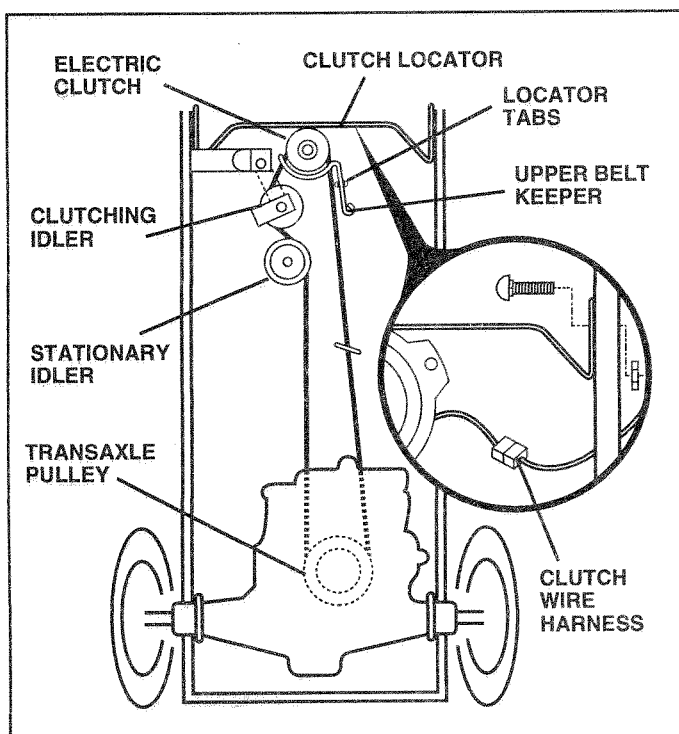

FIG. 32

TRANSAXLE SHIFTER LINKAGE AND ADJUSTMENT (See Figs. 33 and 34)

The transaxle should be in neutral when the gearshift lever is in the neutral (lock gate) position. The adjustment is preset at the factory; however, if adjustment is needed, proceed as follows:

- Make sure transaxle is in neutral.
- Loosen two locknuts on tie rod.
- Turn center rod until gearshift lever falls into neutral lock gate on fender console.
- Tighten locknuts securely.

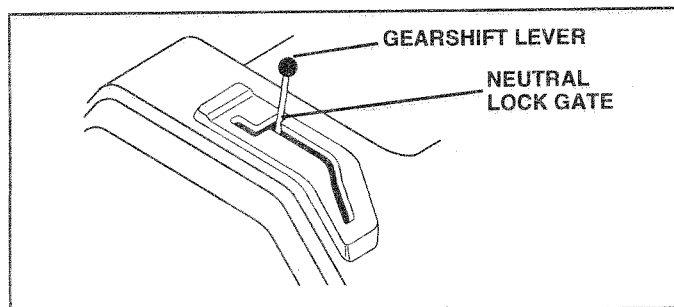

FIG. 33

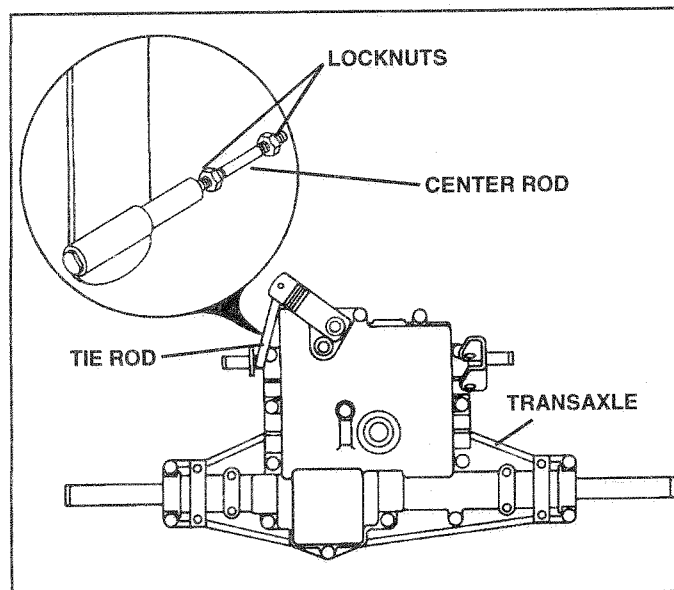

FIG. 34

TO ADJUST STEERING WHEEL ALIGNMENT

If steering wheel crossbars are not horizontal (left to right) when wheels are positioned straight forward, remove steering wheel and reassemble per instructions in the Assembly section of this manual.

FRONT WHEEL TOE-IN/CAMBER

The front wheel toe-in and camber are not adjustable on your tractor. If damage has occurred to affect the front wheel toe-in or camber, contact your nearest authorized service center.

SERVICE AND ADJUSTMENTS

TO REMOVE WHEEL FOR REPAIRS (See Fig. 35)

- Block up axle securely.
- Remove axle cover, retaining ring and washers to allow wheel removal (rear wheel contains a square key - Do not lose).
- Repair tire and reassemble.
- On rear wheels only: align grooves in rear wheel hub and axle. Insert square key.
- Replace washers and snap retaining ring securely in axle groove.
- Replace axle cover.

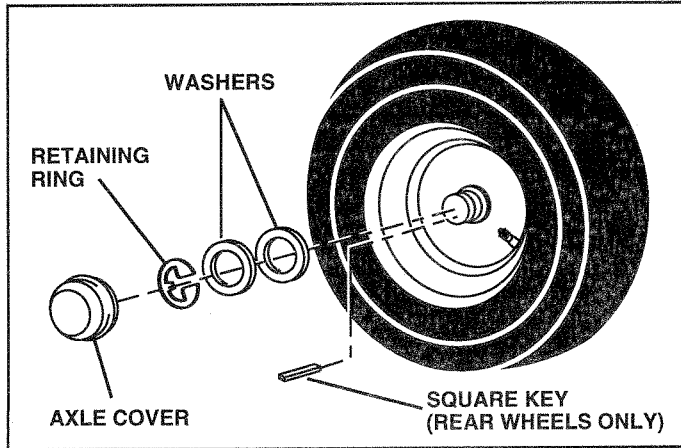

FIG. 35

TO REPLACE FUSE

Replace with 30 amp automotive-type plug-in fuse. The fuse holder is located behind the dash.

TO REPLACE HEADLIGHT BULB

- Raise hood.
- Pull bulb holder out of the hole in the backside of the grill.
- Replace bulb in holder and push bulb holder securely back into the hole in the backside of the grill.
- Close hood.

INTERLOCKS AND RELAYS

Loose or damaged wiring may cause your tractor to run poorly, stop running, or prevent it from starting.

- Check wiring. See the electrical wiring diagram in the Repair Parts section of this manual.

TO START ENGINE WITH A WEAK BATTERY (See Figs. 36 and 37)



CAUTION: Lead-acid batteries generate explosive gases. Keep sparks, flame and smoking materials away from batteries. Always wear eye protection when around batteries.

If your battery is too weak to start the engine, it should be recharged. If "jumper cables" are used for emergency starting, follow this procedure:

IMPORTANT: YOUR TRACTOR IS EQUIPPED WITH A 12 VOLT NEGATIVE GROUND SYSTEM. THE OTHER VEHICLE MUST ALSO BE A 12 VOLT NEGATIVE GROUND SYSTEM. DO NOT USE YOUR TRACTOR BATTERY TO START OTHER VEHICLES.

TO ATTACH JUMPER CABLES -

- Connect each end of the RED cable to the POSITIVE (+) terminal of each battery, taking care not to short against chassis.
- Connect one end of the BLACK cable to the NEGATIVE (-) terminal of fully charged battery.
- Connect the other end of the BLACK cable to a panel bolt on the left side of the chassis, away from the fuel tank and battery.

TO REMOVE CABLES, REVERSE ORDER -

- BLACK cable first from chassis and then from the fully charged battery.
- RED cable last from both batteries.

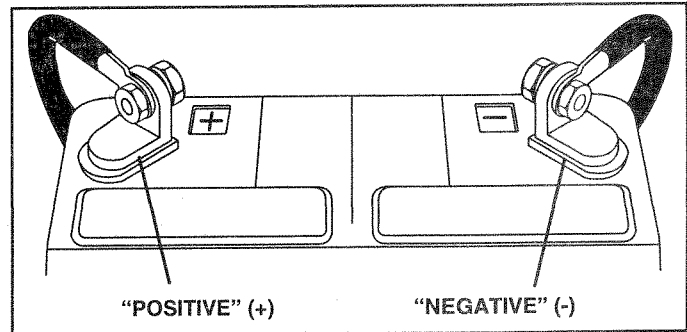

FIG. 36

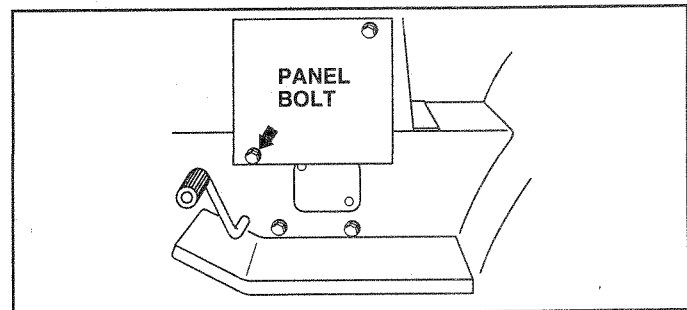

FIG. 37

SERVICE AND ADJUSTMENTS

TO REMOVE HOOD AND GRILL ASSEMBLY

(See Fig. 38)

- Lift hood. Disconnect headlight wire connection.
- Remove wing nuts on inside of side panels.
- Pivot hood and side panel forward and lift off tractor.
- To replace, reverse above procedure.

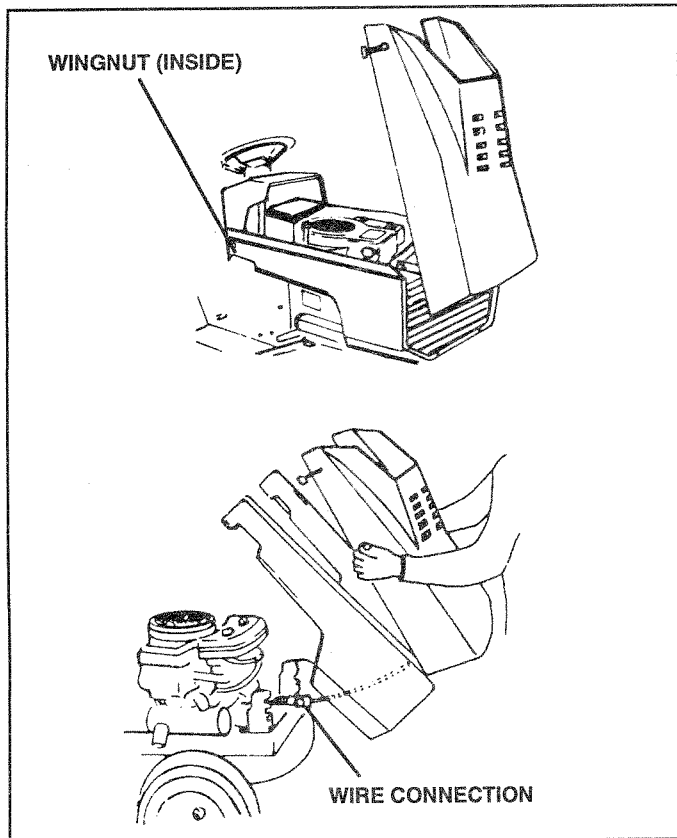

FIG. 38

ENGINE

TO ADJUST THROTTLE CONTROL CABLE (See Fig. 39)

The throttle control has been preset at the factory and adjustment should not be necessary. Check adjustment as described below before loosening cable. If adjustment is necessary, proceed as follows:

- With engine not running, move throttle control lever to "FAST" position.
- Check that swivel is against side of quarter circle. If it is not, loosen cable clamp screw and pull cable back until swivel is against quarter circle. Tighten cable clamp screw securely.

TO ADJUST CHOKE CONTROL (See Fig. 40)

The choke control has been preset at the factory and adjustment should not be necessary. Check adjustment as described below before loosening cable. If adjustment is necessary, proceed as follows:

- With engine not running, move choke control (located on dash panel) to full "CHOKE" position.
- Remove air cleaner cover, filter and spitback plate to expose carburetor choke (see "AIR FILTER" in Customer Responsibilities section).
- Choke should be closed. If it is not, loosen casing clamp screw and move choke cable until choke is completely closed. Tighten casing clamp screw securely.
- Reassemble air cleaner.

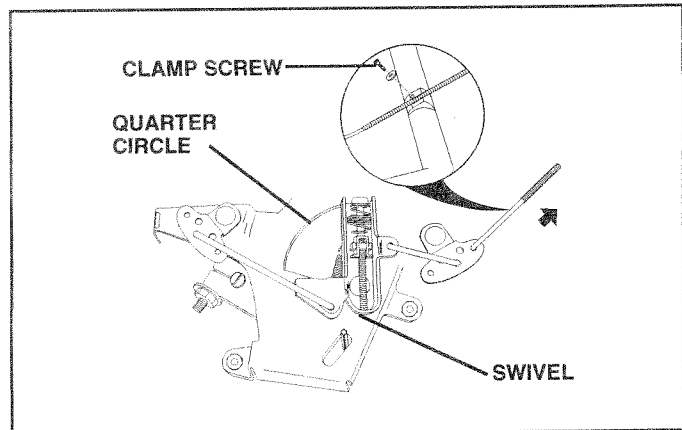

FIG. 39

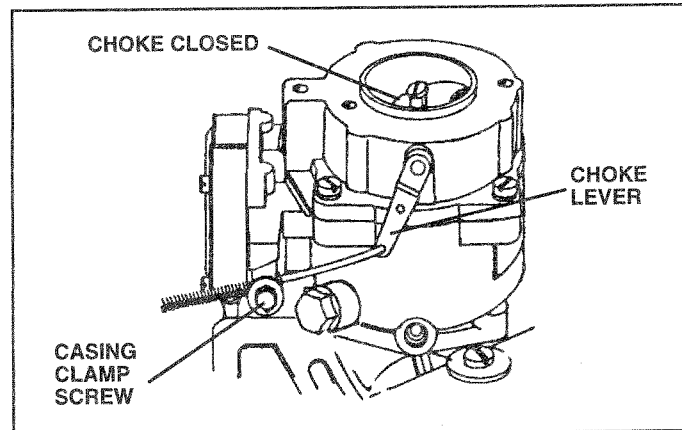

FIG. 40

TO ADJUST CARBURETOR

The carburetor has been preset at the factory and adjustment should not be necessary. However, minor adjustment may be required to compensate for differences in fuel, temperature, altitude or load. If the carburetor does not need adjustment, see the engine manual packed with your tractor.

High speed stop is factory adjusted. Do not adjust-damage may result.

IMPORTANT: NEVER TAMPER WITH THE ENGINE GOVERNOR, WHICH IS FACTORY SET FOR PROPER ENGINE SPEED. OVERSPEEDING THE ENGINE ABOVE THE FACTORY HIGH SPEED SETTING CAN BE DANGEROUS. IF YOU THINK THE ENGINE-GOVERNED HIGH SPEED NEEDS ADJUSTING, CONTACT YOUR NEAREST AUTHORIZED SERVICE CENTER, WHICH HAS PROPER EQUIPMENT AND EXPERIENCE TO MAKE ANY NECESSARY ADJUSTMENTS.

STORAGE

Immediately prepare your tractor for storage at the end of the season or if the tractor will not be used for 30 days or more.



CAUTION: Never store the tractor with gasoline in the tank inside a building where fumes may reach an open flame or spark. Allow the engine to cool before storing in any enclosure.

TRACTOR

Remove mower from tractor for winter storage. When mower is to be stored for a period of time, clean it thoroughly, remove all dirt, grease, leaves, etc. Store in a clean, dry area.

- Clean entire tractor (See "CLEANING" in the Customer Responsibilities section of this manual).
- Inspect and replace belts, if necessary (See belt replacement instructions in the Service and Adjustments section of this manual).
- Lubricate as shown in the Customer Responsibilities section of this manual.
- Be sure that all nuts, bolts and screws are securely fastened. Inspect moving parts for damage, breakage and wear. Replace if necessary.
- Touch up all rusted or chipped paint surfaces; sand lightly before painting.

BATTERY

- Fully charge the battery for storage.
- After a period of time in storage, battery may require recharging.
- To help prevent corrosion and power leakage during long periods of storage, battery cables should be disconnected and battery cleaned thoroughly (see "TO CLEAN BATTERY AND TERMINALS" in the Customer Responsibilities section of this manual).
- After cleaning, leave cables disconnected and place cables where they cannot come in contact with battery terminals.
- Be sure battery drain tube is securely attached.
- If battery is removed from tractor for storage, do not store battery directly on concrete or damp surfaces.

ENGINE

FUEL SYSTEM

IMPORTANT: IT IS IMPORTANT TO PREVENT GUM DEPOSITS FROM FORMING IN ESSENTIAL FUEL SYSTEM PARTS SUCH AS CARBURETOR, FUEL FILTER, FUEL HOSE, OR TANK DURING STORAGE. ALSO, EXPERIENCE INDICATES THAT ALCOHOL BLENDED FUELS (CALLED GASOHOL OR USING ETHANOL OR METHANOL) CAN ATTRACT MOISTURE WHICH LEADS TO SEPARATION AND FORMATION OF ACIDS DURING STORAGE. ACIDIC GAS CAN DAMAGE THE FUEL SYSTEM OF AN ENGINE WHILE IN STORAGE.

- Drain the fuel tank.
- Start the engine and let it run until the fuel lines and carburetor are empty.
- Never use engine or carburetor cleaner products in the fuel tank or permanent damage may occur.
- Use fresh fuel next season.

NOTE: Fuel stabilizer is an acceptable alternative in minimizing the formation of fuel gum deposits during storage. Add stabilizer to gasoline in fuel tank or storage container. Always follow the mix ratio found on stabilizer container. Run engine at least 10 minutes after adding stabilizer to allow the stabilizer to reach the carburetor. Do not drain the gas tank and carburetor if using fuel stabilizer.

ENGINE OIL

Drain oil (with engine warm) and replace with clean engine oil. (See "ENGINE" in the Customer Responsibilities section of this manual).

CYLINDERS

- Remove spark plug(s).
- Pour one ounce of oil through spark plug hole(s) into cylinder(s).
- Turn ignition key to "START" position for a few seconds to distribute oil.
- Replace with new spark plug(s).

OTHER

- Do not store gasoline from one season to another.
- Replace your gasoline can if your can starts to rust. Rust and/or dirt in your gasoline will cause problems.
- If possible, store your tractor indoors and cover it to give protection from dust and dirt.
- Cover your tractor with a suitable protective cover that does not retain moisture. Do not use plastic. Plastic cannot breathe which allows condensation to form and will cause your tractor to rust.

IMPORTANT: NEVER COVER TRACTOR WHILE ENGINE AND EXHAUST ARE STILL WARM.

TROUBLESHOOTING POINTS

PROBLEM	CAUSE	CORRECTION
Will not start	<ol style="list-style-type: none"> 1. Out of fuel. 2. Engine not "CHOKED" properly. 3. Engine flooded. 4. Bad spark plug. 5. Dirty air filter. 6. Dirty fuel filter. 7. Water in fuel. 8. Loose or damaged wiring. 9. Carburetor out of adjustment. 10. Engine valves out of adjustment. 	<ol style="list-style-type: none"> 1. Fill fuel tank. 2. See "TO START ENGINE" in Operation section. 3. Wait several minutes before attempting to start. 4. Replace spark plug. 5. Clean/replace air filter. 6. Replace fuel filter. 7. Drain fuel tank and carburetor, refill tank with fresh gasoline and replace fuel filter. 8. Check all wiring. 9. Contact an authorized service center/department. 10. Contact an authorized service center/department.
Hard to start	<ol style="list-style-type: none"> 1. Dirty air filter. 2. Bad spark plug. 3. Weak or dead battery. 4. Dirty fuel filter. 5. Stale or dirty fuel. 6. Loose or damaged wiring. 7. Carburetor out of adjustment. 8. Engine valves out of adjustment. 	<ol style="list-style-type: none"> 1. Clean/replace air filter. 2. Replace spark plug. 3. Recharge or replace battery. 4. Replace fuel filter. 5. Drain fuel tank and refill with fresh gasoline. 6. Check all wiring. 7. Contact an authorized service center/department. 8. Contact an authorized service center/department.
Engine will not turn over	<ol style="list-style-type: none"> 1. Clutch/brake pedal not depressed. 2. Attachment clutch is engaged. 3. Weak or dead battery. 4. Blown fuse. 5. Corroded battery terminals. 6. Loose or damaged wiring. 7. Faulty ignition switch. 8. Faulty solenoid or starter. 9. Faulty operator presence switch(es). 	<ol style="list-style-type: none"> 1. Depress clutch/brake pedal. 2. Disengage attachment clutch. 3. Recharge or replace battery. 4. Replace fuse. 5. Clean battery terminals. 6. Check all wiring. 7. Check/replace ignition switch. 8. Check/replace solenoid or starter. 9. Contact an authorized service center/department.
Engine clicks but will not start	<ol style="list-style-type: none"> 1. Weak or dead battery. 2. Corroded battery terminals. 3. Loose or damaged wiring. 4. Faulty solenoid or starter. 	<ol style="list-style-type: none"> 1. Recharge or replace battery. 2. Clean battery terminals. 3. Check all wiring. 4. Check/replace solenoid or starter.
Loss of power	<ol style="list-style-type: none"> 1. Cutting too much grass/too fast. 2. Throttle in "CHOKE" position. 3. Build-up of grass, leaves and trash under mower. 4. Dirty air filter. 5. Low oil level/dirty oil. 6. Faulty spark plug. 7. Dirty fuel filter. 8. Stale or dirty fuel. 9. Water in fuel. 10. Spark plug wire loose. 11. Dirty engine air screen/fins. 12. Dirty/clogged muffler. 13. Loose or damaged wiring. 14. Carburetor out of adjustment. 15. Engine valves out of adjustment. 	<ol style="list-style-type: none"> 1. Set in "Higher Cut" position/reduce speed. 2. Adjust throttle control. 3. Clean underside of mower housing. 4. Clean/replace air filter. 5. Check oil level/change oil. 6. Clean and regap or change spark plug. 7. Replace fuel filter. 8. Drain fuel tank and refill with fresh gasoline. 9. Drain fuel tank and carburetor, refill tank with fresh gasoline and replace fuel filter. 10. Connect and tighten spark plug wire. 11. Clean engine air screen/fins. 12. Clean/replace muffler. 13. Check all wiring. 14. Contact an authorized service center/department. 15. Contact an authorized service center/department.
Excessive vibration	<ol style="list-style-type: none"> 1. Worn, bent or loose blade. 2. Bent blade mandrel. 3. Loose/damaged part(s). 	<ol style="list-style-type: none"> 1. Replace blade. Tighten blade bolt. 2. Replace blade mandrel. 3. Tighten loose part(s). Replace damaged parts.

TROUBLESHOOTING POINTS

PROBLEM	CAUSE	CORRECTION
Engine continues to run when operator leaves seat with attachment clutch engaged	1. Faulty operator-safety presence control system.	1. Check wiring, switches and connections. If not corrected, contact an authorized service center/ department.
Poor cut - uneven	1. Worn, bent or loose blade. 2. Mower deck not level. 3. Buildup of grass, leaves, and trash under mower. 4. Bent blade mandrel.	1. Replace blade. Tighten blade bolt. 2. Level mower deck. 3. Clean underside of mower housing. 4. Replace blade mandrel.
Mower blades will not rotate	1. Obstruction in clutch mechanism. 2. Mower drive belt out of adjustment. 3. Worn/damaged mower drive belt. 4. Frozen idler pulley. 5. Frozen blade mandrel.	1. Remove obstruction. 2. Adjust mower drive belt. 3. Replace mower drive belt. 4. Replace idler pulley. 5. Replace blade mandrel.
Poor grass discharge	1. Engine speed too slow. 2. Travel speed too fast. 3. Wet grass. 4. Mower deck not level. 5. Low/uneven tire air pressure. 6. Worn, bent or loose blade. 7. Buildup of grass, leaves and trash under mower. 8. Mower drive belt worn or out of adjustment. 9. Blades improperly installed. 10. Improper blades used.	1. Place throttle control in "FAST" position. 2. Shift to slower speed. 3. Allow grass to dry before mowing. 4. Level mower deck. 5. Check tires for proper air pressure. 6. Replace/sharpen blade. Tighten blade bolt. 7. Clean underside of mower housing. 8. Replace/adjust mower drive belt. 9. Reinstall blades sharp edge down. 10. Replace with blades listed in this manual.
Headlight(s) not working (if so equipped)	1. Switch is "OFF". 2. Bulb(s) burned out. 3. Faulty light switch. 4. Loose or damaged wiring. 5. Blown fuse.	1. Turn switch "ON". 2. Replace bulb(s). 3. Check/replace light switch. 4. Check wiring and connections. 5. Replace fuse.
Battery will not charge	1. Bad battery cell(s). 2. Poor cable connections. 3. Faulty regulator (if so equipped). 4. Faulty alternator.	1. Replace battery. 2. Check/clean all connections. 3. Replace regulator. 4. Replace alternator.
Engine "backfires" when turning engine "OFF"	1. Engine throttle control not set at "SLOW" position for 30 seconds before stopping engine.	1. Move throttle control to "SLOW" position and allow to idle for 30 seconds before stopping engine.

18 HP 44" TRACTOR - - MODEL NUMBER X1844A

SCHEMATIC

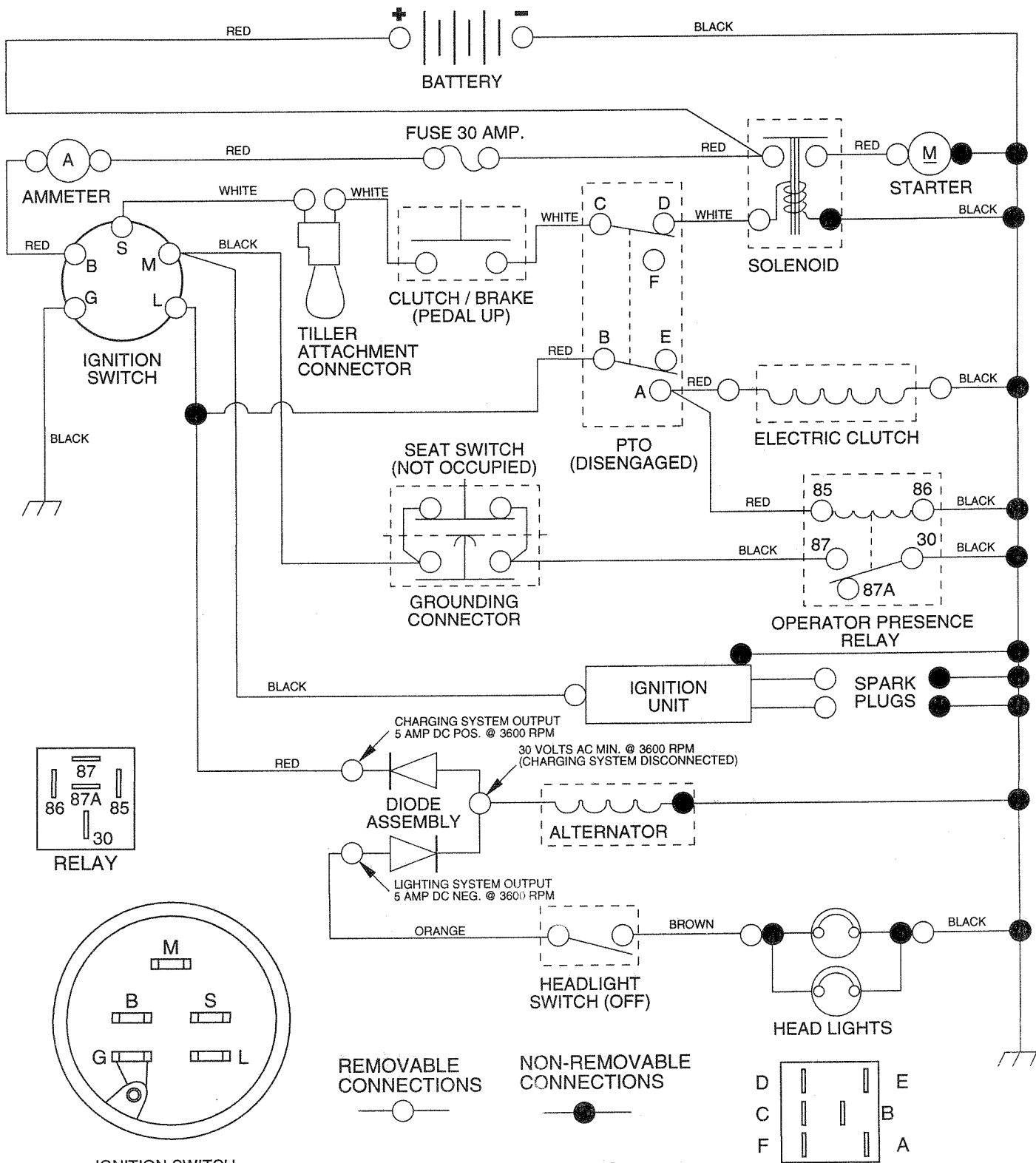

POSITION	CIRCUIT
OFF	M + G
ON	B + L
START	B + S

WIRING INSULATED CLIPS

NOTE: IF WIRING INSULATED CLIPS WERE REMOVED FOR SERVICING OF UNIT, THEY SHOULD BE REPLACED TO PROPERLY SECURE YOUR WIRING

POSITION	CIRCUIT
OFF	B + E, C + D
ON	B + A, C + F

REPAIR PARTS

18 HP 44" TRACTOR -- MODEL NUMBER X1844A

DECALS

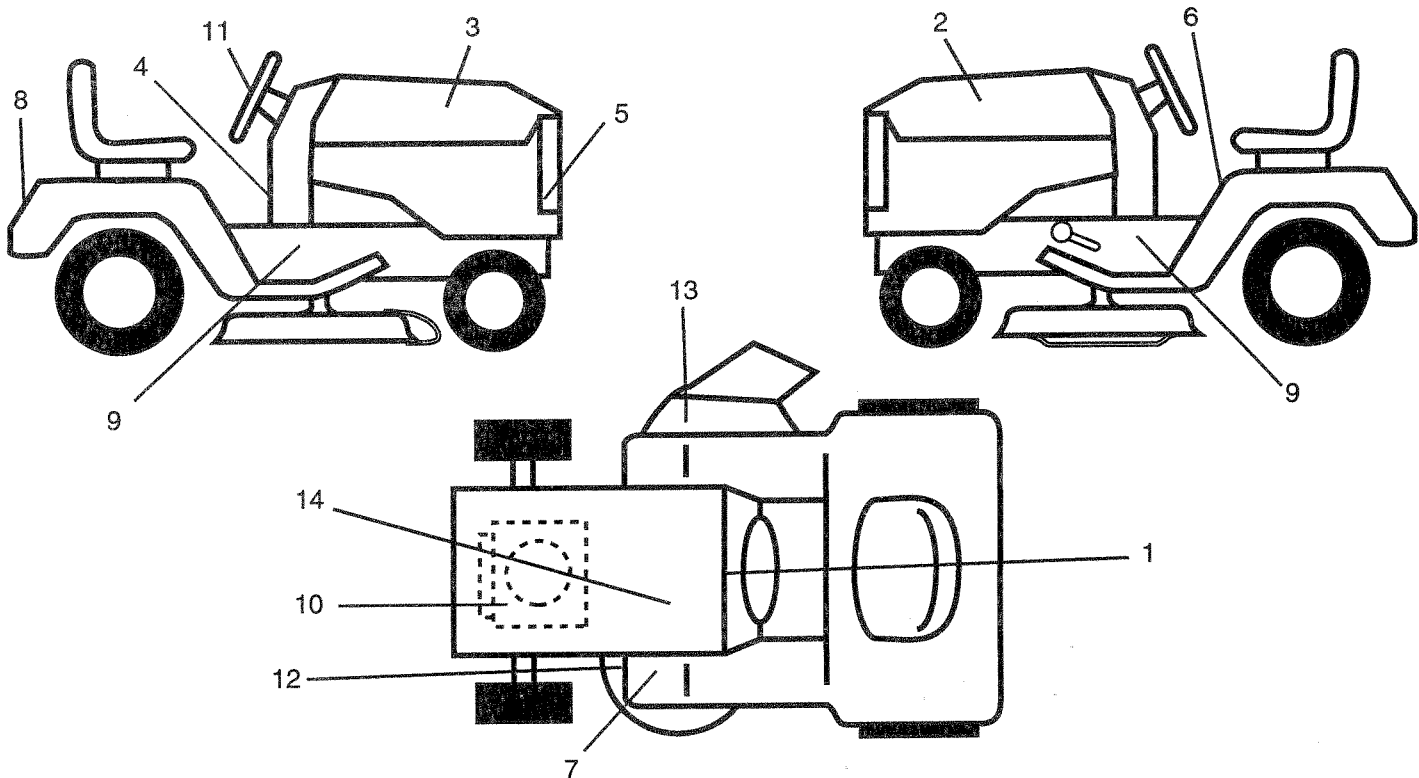

KEY NO.	PART NO.	DESCRIPTION
1	138956	Decal, Operating Instructions
2	128018	Decal, Hood, LH
3	128015	Decal, Hood, RH
4	138956	Decal Dash Inst.
5	128007	Decal Grille
6	133795	Decal, Caution
7	101892X	Decal, Clutch/Brake
8	128006	Decal Fender
9	134545	Decal Chassis
10	135426	Decal, Engine B&S 18 HP

KEY NO.	PART NO.	DESCRIPTION
11	128009	Decal, Steering Wheel Insert
12	136834	Decal V-Belt Schematic
13	137259	Decal Warning
14	121549X	Decal Caution
--	138311	Decal, Handle Lift
--	139700	Manual, Owner's
Available accessories (not included with tractor):		
	SB10	40" Snow Blower
	LC02	42" Snow Blade
	TA321	55 lb. Wheel Wts. (ea.)
	TX11	Sleeve Hitch
	LA028	Tire Chains 23 x 8.5 x 12
	TS15	P.T.O. Tiller
	TR69	48" Dozer Blade

WHEELS AND TIRES

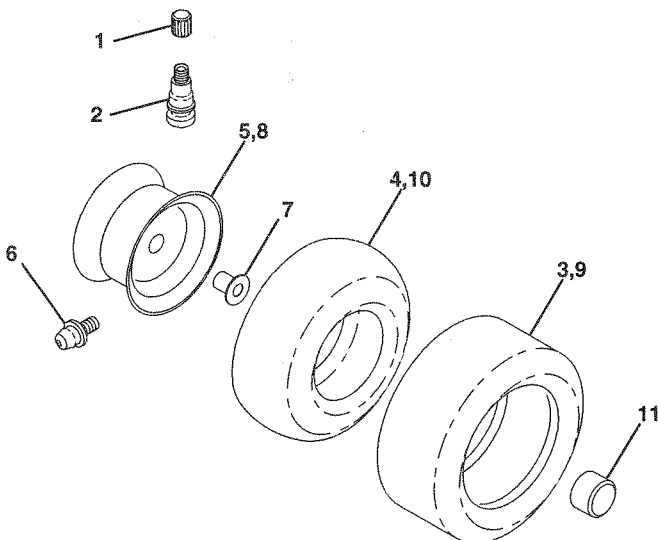

KEY NO.	PART NO.	DESCRIPTION
1	59192	Valve Cap, Tire
2	65139	Stem, Valve
3	106222X	Tire, Front
4	59904	Tube, Front (Service Item Only)
5	106732X475	Rim Assembly, Front
6	278H	Fitting, Grease (Front Wheel Only)
7	9040H	Bearing, Flange (Front Wheel Only)
8	124074X475	Rim Assembly, Rear
9	124106X	Tire, Rear
10	7154J	Tube, Rear (Service Item Only)
11	104757X	Cap, Axle, Black 1.50 x 1.00

NOTE: All component dimensions given in U.S. inches.
1 inch = 25.4 mm

REPAIR PARTS

18 HP 44" TRACTOR -- MODEL NUMBER X1844A

ELECTRICAL

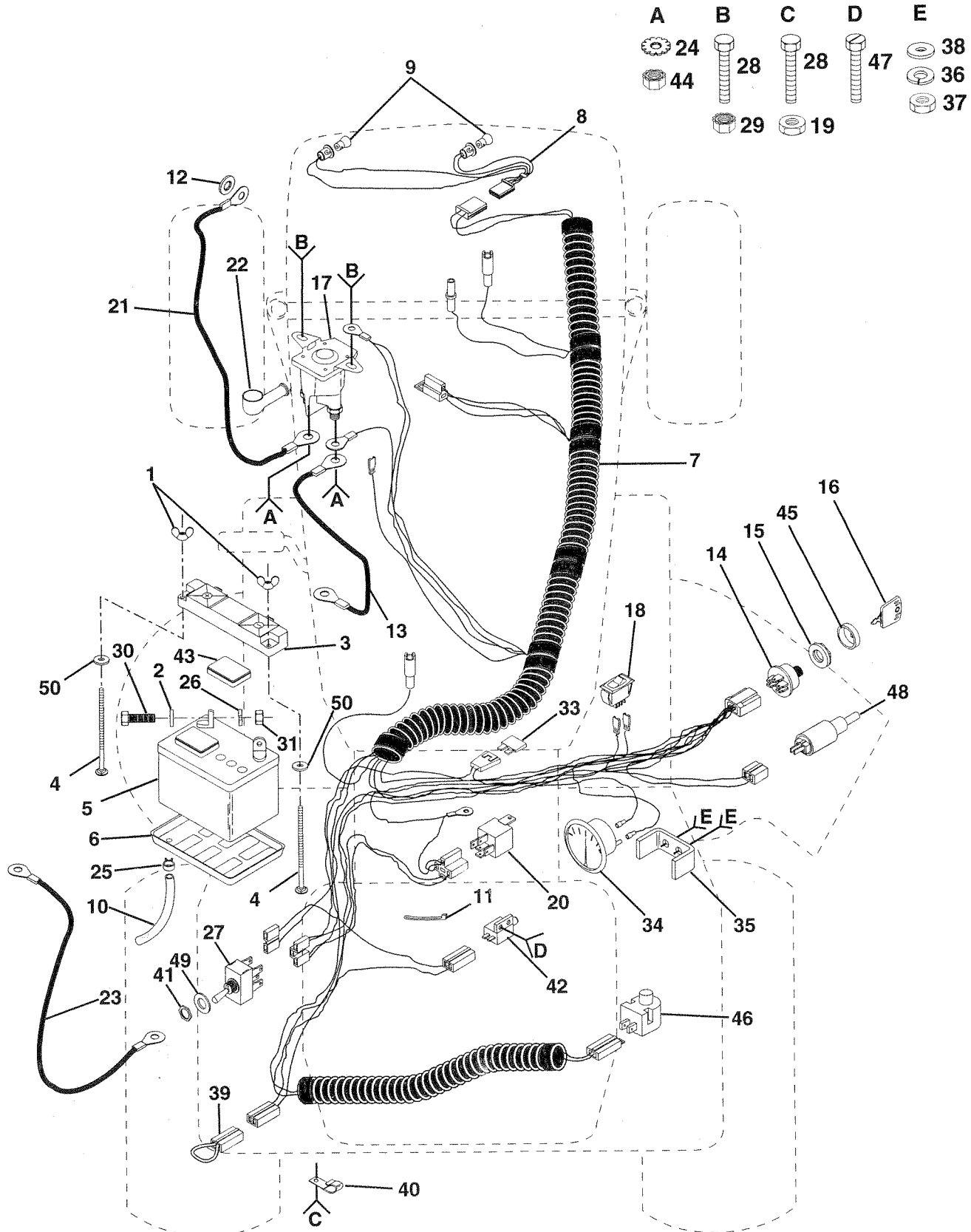

REPAIR PARTS

18 HP 44" TRACTOR - - MODEL NUMBER X1844A

ELECTRICAL

KEY NO.	PART NO.	DESCRIPTION
1	123198X	Wingnut 1/4-20
2	19091016	Washer 9/32 x 5/8 x 16 Ga.
3	102476X	Guard, Terminal
4	72240460	Bolt, Carriage 1/4-20 x 7-1/2
5	121537X	Battery
6	7603J	Tray, Battery
7	138803	Harness, Ignition
8	136849	Harness, Light Socket
9	7662J	Bulb, Light
10	7697J	Tube, Battery Tray
11	7192J	Cable Tie
12	11150400	Washer, Lock Internal Tooth 1/4
13	4206J	Cable, Battery (Battery to Solenoid)
14	4406R	Switch, Ignition
15	124211X	Nut, Ignition
16	122147X	Key, Molded
17	138406	Solenoid
18	110712X	Switch, Light
19	73680400	Nut, Hex 1/4-20
20	109748X	Relay
21	4799J	Cable, Battery (Solenoid to Starter)
22	131563	Cover, Terminal (For Solenoid)
23	4207J	Cable, Battery (Battery to Ground)
24	10090400	Washer, Lock, External Tooth 1/4
25	109596X	Clamp, Hose
26	10040400	Washer, Lock 1/4
27	126016X	Switch, PTO
28	71110408	Bolt, Hex 1/4-20 x 1/2 Gr. 5
29	73640400	Nut, Keps, Hex 1/4-20
30	74760412	Bolt, Hex 1/4-20 x 3/4
31	73220400	Nut, Hex 1/4-20
32	11050400	Washer, Lock, External Tooth 1/4
33	108824X	Fuse, 30 AMP
34	9433R	Ammeter
35	131708	Bracket, Ammeter
36	10101000	Washer, Lock #10
37	73911000	Nut
38	19070818	Washer 7/32 x 1/2 x 18 Ga.
39	102501X	Loop, Wire
40	235R	Clip, Insulated
41	4022J	Nut, Hex
42	104445X	Switch, Interlock, Clutch
43	121264X	Cap, Battery
44	73350400	Nut, Keps #10-32 UNF
45	123620X	Bezel, Ignition
46	121305X	Switch, Plunger
47	17021008	Screw, Hex, Tapping #10-24 UNC x 1/2 Type T
48	135665	Diode Assembly
49	19171216	Washer 17/32 x 3/4 x 16 Ga.
50	19121618	Washer 3/4 x 1 x 18 Ga.

NOTE: All component dimensions given in U.S. inches.
1 inch = 25.4 mm

REPAIR PARTS

18 HP 44" TRACTOR - - MODEL NUMBER X1844A

CHASSIS AND ENCLOSURES

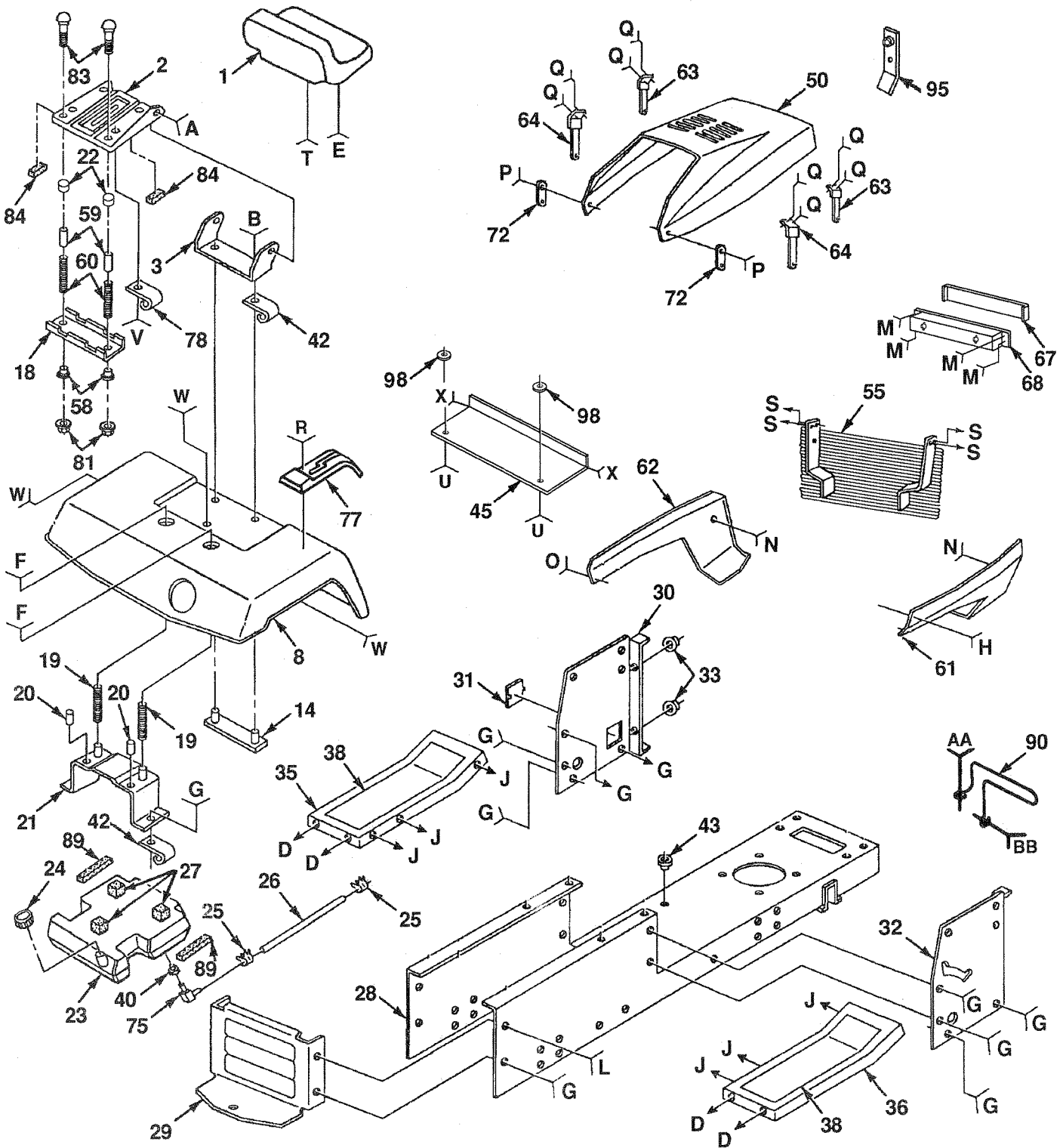

- | | | | | | | | | | | | | | | | | | | | | | | |
|---|---|----|----|----|----|----|----|----|----|----|----|----|----|----|----|----|----|----|----|----|----|----|
| A | B | D | E | F | G | H | J | L | M | N | O | P | Q | R | S | T | U | V | W | X | AA | BB |
| 4 | 7 | 13 | 10 | 88 | 11 | 52 | 37 | 74 | 71 | 54 | 41 | 69 | 46 | 73 | 57 | 82 | 44 | 80 | 87 | 96 | 91 | 93 |
| 6 | 7 | 12 | 15 | 85 | | 51 | 7 | 7 | 70 | 53 | | 66 | 76 | 86 | 56 | | | 79 | | 97 | 92 | 94 |
| | | | | | | 49 | | | | | | 65 | | | | | | | | | | |
| | | | | | | 48 | | | | | | | | | | | | | | | | |

REPAIR PARTS

18 HP 44" TRACTOR - - MODEL NUMBER X1844A

CHASSIS AND ENCLOSURES

KEY PART NO. NO.	DESCRIPTION	KEY PART NO. NO.	DESCRIPTION
1	127429	Seat	
2	131451	Pan, Seat	
3	126656X	Bracket, Pivot, Seat	
4	105529X	Bolt, Shoulder 5/16-18	
6	73680500	Nut, Crownlock 5/16-18	
7	73680600	Nut, Crownlock 3/8-16	
8	123784X475	Fender	
10	120068X	Knob, Seat	
11	17490612	Screw, Hex Washer Head, Thd. Roll. 3/8-16 x 3/4	
12	19131312	Washer 13/32 x 13/16 x 12 Gauge	
13	74760612	Bolt, Hex 3/8-16 x 3/4	
14	105511X	Strap, Fender	
15	19171912	Washer 11/32 x 13/16 x 12 Gauge	
18	121246X	Bracket, Switch, Seat	
19	124181X	Spring, Compression	
20	105531X	Nut, Push	
21	137113	Bracket, Fender	
22	124238X	Cap, Spring, Seat	
23	127334X	Tank, Fuel	
24	123549X	Cap, Fuel	
25	123487X	Clamp, Hose	
26	7834R	Line, Fuel	
27	106082X	Pad, Spacer	
28	127166X	Chassis Assembly	
29	123785X	Drawbar	
30	138644	Panel, Dash, LH	
31	121794X	Cover, Access	
32	138643	Bushing, Snap	
35	105465X475	Footrest, LH	
36	105464X475	Footrest, RH	
37	72110606	Bolt, Carriage 3/8-16 x 3/4	
38	133671	Pad, Footrest	
40	3645J	Bushing	
41	123198X	Wing Nut, Plastic, Locking 1/4-20	
42	2751R	Clip, Insulated	
43	110436X	Grommet, Split	
44	17490512	Screw, Thd. Roll. 5/16-18 x 3/4	
45	105419X475	Strap, Grille	
46	73510400	Nut, Keps 1/4-20	
48	73731000	Nut, Keps #10-24	
49	19070818	Washer 7/32 x 1/2 x 18 Gauge	
50	132635X475	Hood	
51	7206J	Spacer, Split	
52	74981020	Screw, Machine #10-24 x 1-1/4	
53	73220400	Nut, Hex, Fin. 1/4-20	
54	19091216	Washer 9/32 x 3/4 x 16 Gauge	
55	131681	Grille	
56	73680400	Nut, Crownlock 1/4-20	
57	123481X	Bolt, Shoulder 1/4-20	
58	121248X	Bushing, Snap	
59	121249X	Spacer, Split	
60	123740X	Spring, Compression	
61	132639X475	Panel, Side, RH	
62	132638X475	Panel, Side, LH	
63	104618X	Strap Assembly, Hinge, Front	
64	106784X	Strap Assembly, Hinge, Rear	
65	2029J	Nut, Welded #10-24	
66	10071000	Washer, Lock	
67	106395X	Lens, Headlight, Bar	
68	124392X417	Bezel, Headlight	
69	74191008	Screw, Machine #10-24 x 1/2	
70	104755X	"J" Fastener	
71	17211010	Screw, Hex Washer Head, Tapping	
72	109808X	Latch, Chute	
73	74640806	Screw #8 x 3/8	
74	74760612	Bolt, Hex 3/8-16 x 3/4	
75	139227	Stem, Fuel Tank	
76	10100800	Washer, Lock #8	
77	123825X	Console, Shifter	
78	4171R	Clip, Insulated	
79	73951000	Nut, Keps #10-24	
80	74641008	Screw, Slotted Pan Head #10-24 x 1/4	
81	123976X	Nut, Hex, Flange, Large	
82	127018X	Bolt, Shoulder	
83	72050411	Bolt, Carriage 1/4-20 x 1-3/8	
84	121251X	Strip, Foam	
85	19131614	Washer 13/32 x 1 x 14 Gauge	
86	19060718	Washer 3/16 x 7/16 x 18 Gauge	
87	17490608	Screw Thdrol 3/8-16 x 1/2	
88	17490508	Screw Thdrol 5/16-18 x 1/2	
89	109227X	Pad Spacer	
90	135029	Guard Muffler	
91	17490616	Screw Thdrol 3/8-16 x 1	
92	19131616	Washer 13/32 x 1 x 16 Ga.	
93	72110608	Bolt Rdhd Sqnk 3/8-16 x 1 Gr. 5	
94	73680600	Nut, Crownlock 3/8-16	
95	132644	Bracket Grille	
96	17490412	Screw Hexwash	
97	19091016	Washer 9/32 x 5/8 x 16 Ga.	
98	19131210	Washer 13/32 x 3/4 x 10 Ga.	

NOTE: All component dimensions given in U.S. inches
1 inch = 25.4 mm

REPAIR PARTS

18 HP 44" TRACTOR -- MODEL NUMBER X1844A

DRIVE

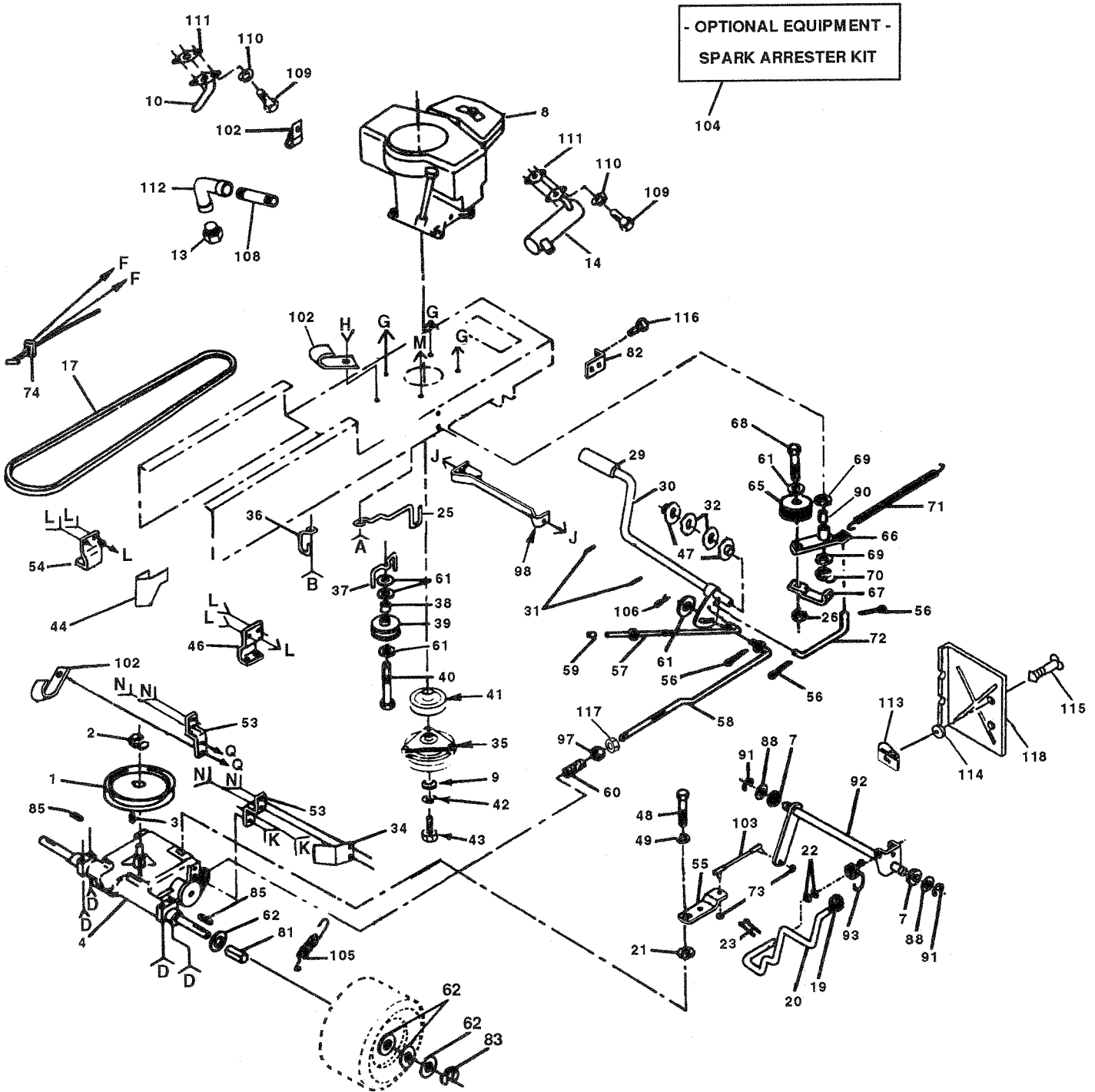

- | | | | | | | | | | | | |
|----------|----------|----------|----------|----------|----------|----------|----------|----------|----------|----------|----------|
| A | B | D | F | G | H | J | K | L | M | N | Q |
| 26 | 24 | 52 | 75 | 87 | 28 | 5 | 101 | 89 | 87 | 24 | 12 |
| 27 | 27 | 6 | | | | 116 | 51 | 28 | 94 | | |
| 28 | | 51 | | | | 51 | | | | | |

REPAIR PARTS

18 HP 44" TRACTOR - - MODEL NUMBER X1844A

DRIVE

KEY PART NO. NO.

KEY PART NO.	NO.	DESCRIPTION
1	121327X	Pulley, Transaxle
2	12000004	Ring, Retainer
3	2228M	Key, Woodruff #9
4	138788	Transaxle, Peerless, 6 Speed, Model Number 820-016B
5	72140506	Bolt, Carriage 5/16-18 x 3/4
6	19111214	Washer 11/32 x 3/4 x 14 Ga.
7	71208	Bushing, Rod, Steering
8	---	Engine, B&S, 18 HP, Model No. 422707
9	126197X	Washer 15/32 x 1-3/4 x 1/4
10	100229L	Tube, Exhaust
12	17490512	Screw, Hex Wash Head 5/16-18 x 2-1/2
13	---	Plug, Oil Drain (Order from Engine Manufacturer)
14	108373X	Muffler
17	123796X	V-Belt, Drive
19	106933X	Knob
20	123781X	Rod, Shifter
21	105701X	Washer, Shift Plate
22	19171216	Washer 17/32 x 3/4 x 16 Gauge
23	76020416	Pin, Cotter 1/8 x 1
24	17490612	Screw, Hex Washer Head, Thd., Roll. 3/8-16 x 3/4
25	129921	Keeper, Belt, Engine, LH
26	74760616	Bolt, Hex Head 3/8-16 x 1
27	19131312	Washer 13/32 x 13/16 x 12 Gauge
28	73680600	Nut, Crownlock 3/8-16
29	8883R	Cover, Foot Pedal
30	122424X	Shaft, Foot Pedal
31	1572H	Pin, Roll 3/16 x 1
32	19211616	Washer 21/32 x 1 x 16 Gauge
34	123792X	Keeper, Belt, Transaxle, RH
35	137140	Clutch, Electric
36	136715	Retainer, Belt
37	109070X	Keeper, Belt
38	4470J	Spacer
39	123674X	Idler, Flat
40	74760644	Bolt, Hex 3/8-16 x 2-3/4
41	136906	Pulley, Engine
42	10040700	Washer, Lock 7/16
43	71170768	Bolt, Hex Head 7/16-20 x 4-1/4
44	123791X	Keeper, Belt, Transaxle, LH
46	123776X	Bracket, Transaxle, RH
47	120183X	Bearing, Nylon
48	71040412	Bolt, Hex Head 1/4-28 x 3/4
49	19091216	Washer 9/32 x 3/4 x 16 Gauge
51	73680500	Nut, Crownlock 5/16-18
52	74780544	Bolt, Hex 5/16-18 x 2-3/4
53	123787X	Strap, Torque
54	123780X	Bracket, Transaxle, LH
55	123794X	Arm, Shifter
56	76020412	Pin, Cotter 1/8 x 3/4

KEY PART NO. NO.

KEY PART NO.	NO.	DESCRIPTION
57	133261	Rod, Parking Brake
58	123786X	Rod, Brake
59	71673	Cap, Plunger
60	126909X	Spring, Brake Rod
61	19131316	Washer 13/32 x 13/16 x 16 Gauge
62	123800X	Washer 1-1/32 x 1-5/8 x 16 Gauge
65	127783	Pulley, Idler
66	123789X	Arm, Idler
67	123205X	Retainer, Belt
68	74760624	Bolt, Hex Head 3/8-16 x 1-1/2
69	110812X	Washer, Hardened
70	12000039	Ring, Clip
71	105709X	Spring, Return, Clutch
72	105710X	Link, Clutch
73	73530400	Nut 1/4-28
74	132747	Control, Throttle
75	17720410	Screw, Hex Head, Thread Cutting 1/4-20 x 5/8
81	108097X	Spacer, Split
82	108236X	Bracket, Switch
83	12000053	E-Ring
85	9396E	Key, Square 1/4 x 2
87	17490624	Screw, Hex Washer Head, Thd., Roll. 3/8-16 x 1-1/2
88	19212016	Washer 21/32 x 1-1/4 x 16 Gauge
89	74760612	Bolt, Hex Head 3/8-16 x 3/4
90	105706X	Bearing
91	12000008	Ring, Klip
92	123772X	Shaft Assembly, Shifter
93	123782X	Spring, Torsion
94	11050600	Washer, Lock, External Tooth 3/8
97	73800600	Locknut 3/8-16
98	137141	Retainer Assembly, Clutch
101	74760540	Screw, Hex Washer Head, Thd., Roll. 5/16-18 x 2-1/2
102	2751R	Clip, Fuel Line
103	123793X	Rod, Tie
104	121851X	Spark Arrester Kit
105	110422X	Spring, Brake Return
106	4497H	Clip, Hair Pin
108	13280336	Nipple, Pipe
109	74780412	Bolt Fin Hex 1/4-20 x .75
110	10040400	Washer, Lock 1/4
111	8545J	Gasket Muffler
112	13200300	Elbow, Pipe, STD 90°
113	105839X	Receptacle 1/4 Turn
114	105838X	Retainer 1/4 Turn
115	123650X	Stud 1/4 Turn
116	17021008	Screw
117	73350600	Nut, Hex, Jam 3/8-16
118	133746	Shield Heat Elect.
119	19111012	Washer 11/32 x 5/8 x 12 Ga.

NOTE: All component dimensions given in U.S. inches
1 inch = 25.4 mm

REPAIR PARTS

18 HP 44" TRACTOR - - MODEL NUMBER X1844A

STEERING ASSEMBLY

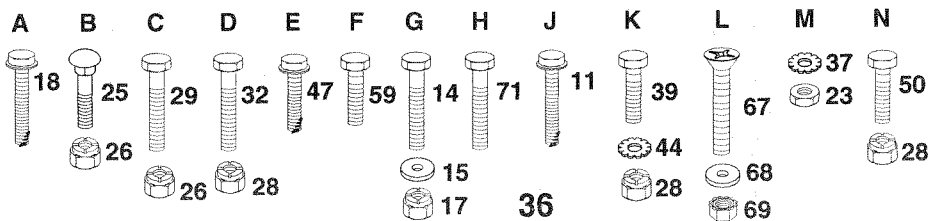
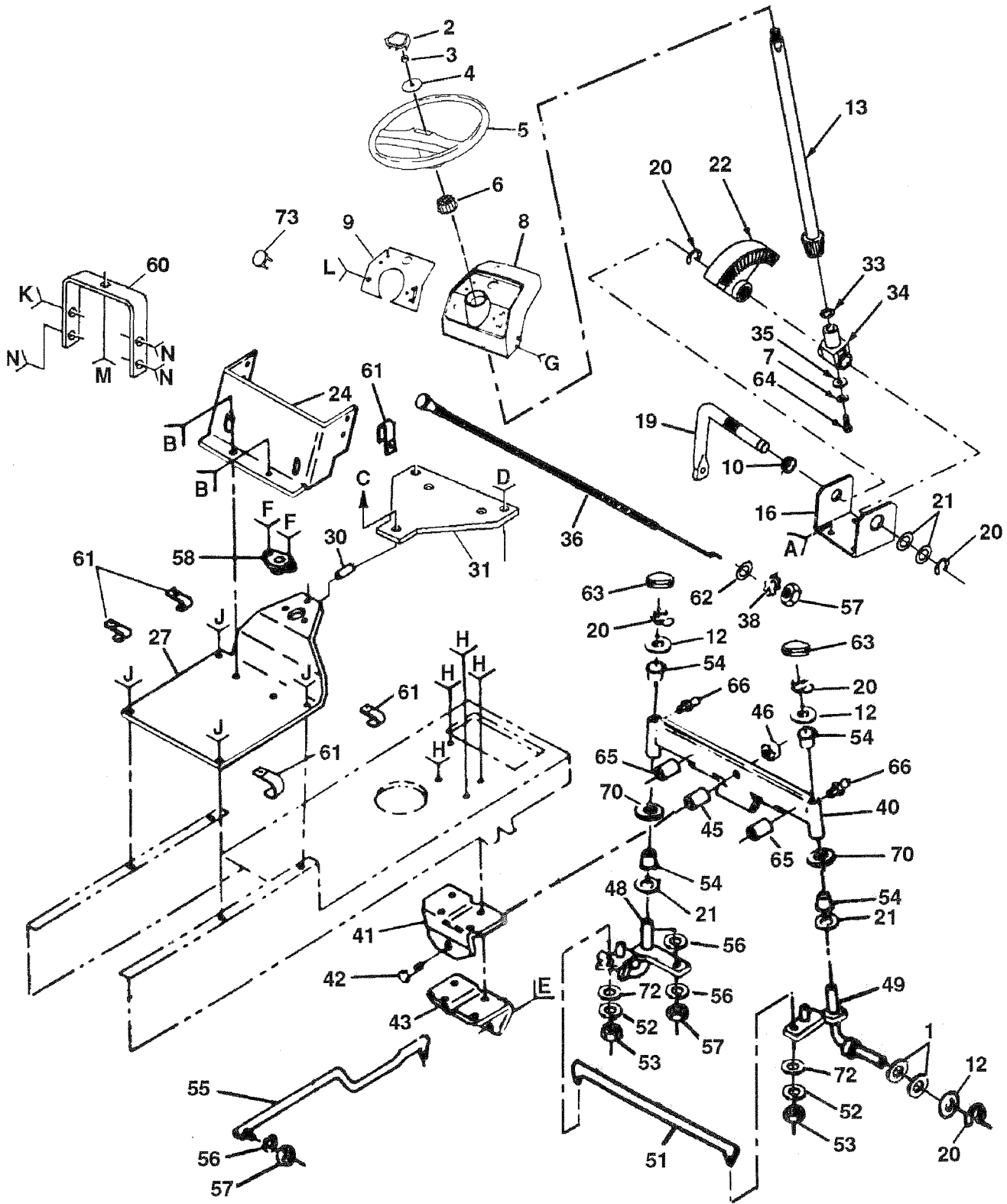

PAIR PARTS

18 HP 44" TRACTOR - - MODEL NUMBER X1844A

STEERING ASSEMBLY

PART NO.	DESCRIPTION	KEY PART NO.	DESCRIPTION
121749X	Washer 25/32 x 1-1/4 x 16 Gauge	38	11050600 Washer, Lock, Internal/External
126805X	Insert, Steering Wheel		Tooth 3/8
73940800	Nut, Hex, Jam, Top Lock	39	74760616 Bolt, Fin, Hex 3/8-16 x 1
	1/2-20 UNF	40	108075X Axle, Front
100712K	Washer	41	105663X Support, Saddle, Rear
121472X	Steering Wheel	42	74761060 Bolt, Hex 5/8-11 x 3-3/4
100711L	Adapter, Steering Wheel	43	105664X Support, Saddle, Front
10040400	Washer, Lock 1/4	44	11050600 Washer, Lock, External Tooth
124252X	Dash	45	110438X Spacer, Bearing, Front Axle
121444X020	Dash Plate	46	73901000 Locknut, Flanged 5/8-11 UNC
109816X	Nyliner, Snap-In	47	17490508 Screw, Hex Washer Head, Thd.,
17490608	Screw, Hex Washer Head, Thd.,		Roll. 5/16-18 x 1/2
	Roll. 3/8-16 x 1/2	48	135227 Spindle, LH
121748X	Washer 25/32 x 1-5/8 x 16 Gauge	49	135228 Spindle, RH
128762	Shaft, Steering	50	74760612 Bolt, Fin, Hex 3/8-16 x 3/4
74760616	Bolt, Hex 3/8-16 x 1	51	130467 Rod, Tie
19131312	Washer 13/32 x 13/16 x 12 Gauge	52	10040500 Washer, Lock 5/16
124036X	Bracket, Steering	53	73810500 Nut, Hex 5/16-24
73680600	Nut, Crownlock 3/8-16	54	3366R Bearing
17490612	Screw, Hex Washer Head, Thd.,	55	130468 Link, Drag
	Roll. 3/8-16 x 3/4	56	10040600 Washer, Lock 3/8
127501	Shaft, Pitman	57	73610600 Nut, Hex 3/8-24
12000029	Klip Ring	58	1554J Bushing, Steering
6266H	Bearing, Thrust	59	17431008 Screw, Hex #10-16 x 1/2
136874	Gear, Sector	60	124130X Support, Dash
73220400	Nut, Fin, Hex 1/4-20	61	2751R Clip, Fuel Line
104805X	Dash, Lower	62	19131316 Washer 13/32 x 13/16 x 16 Gauge
74180512	Screw, Crown, Truss Head	63	121232X Spindle, Cap
	5/16-18 x 3/4	64	71070410 Screw, Hex Socket Head
73680500	Nut, Crownlock 5/16-18		1/4 x 20 x 5/8
123783X016	Saddle	65	132624 Pin, Axle 5/8 x 1.55/1.54
73680600	Nut, Crownlock 3/8-16	66	6855M Grease Zerk
74760532	Bolt, Hex 5/16-18 x 2	67	74180512 Screw, Pan Head 5/16-18 x 3/4
121236X	Spacer	68	19111116 Washer 13/32 x 11/16 x 16 Gauge
137654	Support, Battery	69	73510500 Nut, Keps 5/16-18
74760612	Bolt, Hex 3/8-16 x 3/4	70	19272016 Washer 27/32 x 1-1/4 x 16 Gauge
57079	Washer	71	122819X Screw, Special 3/8-16 x 3/4
124035X	Shaft, Support	72	19111216 Washer 11/32 x 3/4 x 16 Gauge
126684X	Washer 5/8 x 1/4 x 16 Gauge	73	8022J Plug Dash
132781	Control, Choke		
11050400	Washer, Lock, External Tooth		

NOTE: All component dimensions given in U.S. inches
1 inch = 25.4 mm

REPAIR PARTS

18 HP 44" TRACTOR -- MODEL NUMBER X1844A

LIFT ADJUSTMENT

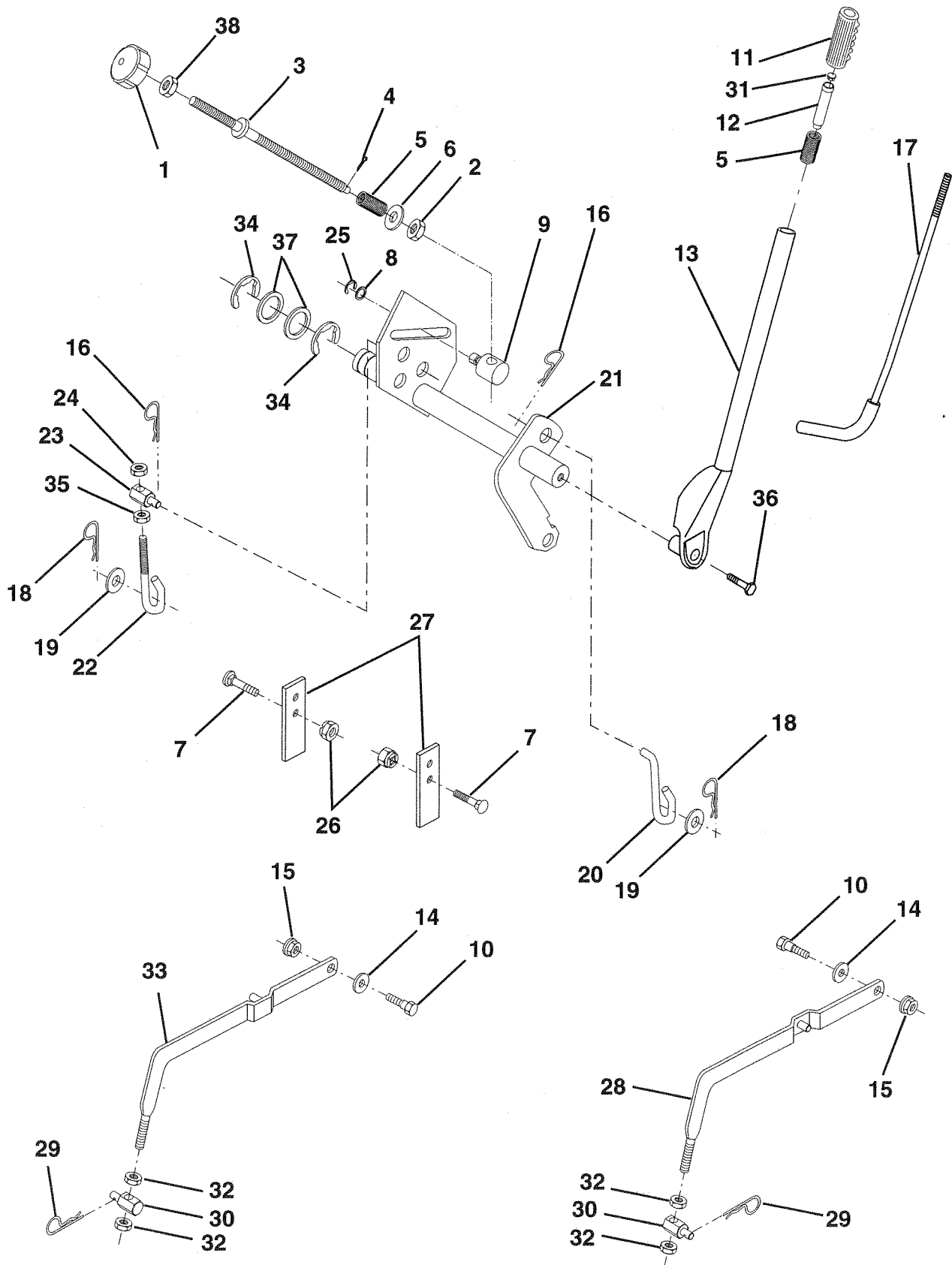

REPAIR PARTS

18 HP 44" TRACTOR - - MODEL NUMBER X1844A

LIFT ADJUSTMENT

KEY PART NO.	NO.	DESCRIPTION
1	138057	Knob, Infinite Height Adjustment
2	110807X	Nut, Hex, Special
3	110729X	Rod, Adjust, Lift
4	76020308	Pin, Cotter 3/32 x 1/2
5	2876H	Spring
6	19131016	Washer 13/32 x 5/8 x 16 Gauge
7	72140608	Bolt, Carriage 3/8-16 x 1
8	19151216	Washer 15/32 x 3/4 x 16 Gauge
9	110810X	Trunnion
10	105848X	Bolt, Shoulder 3/8-16
11	109413X	Grip, Handle
12	122364X	Plunger, Lever
13	121002X	Lever, Lift (Includes Key No. 17)
14	110739X	Washer, Spring
15	73980600	Nut, Flangelock 3/8-16
16	4939M	Retainer, Spring
17	121006X	Rod, Lever
18	4921H	Retainer, Spring
19	19171516	Washer 17/32 x 15/16 x 16 Gauge
20	110029X	Link, Lift
21	131926	Shaft, Lift
22	110448X	Link, Lift, Adjust
23	110447X	Trunnion, Lift
24	73710700	Nut, Crownlock 7/16-20 UNF
25	12000037	Klip Ring
26	73680600	Nut, Crownlock 3/8-16
27	121252X	Upstop Mower
28	121598X	Arm, Suspension, RH
29	9135R	Retainer Spring
30	106308X	Trunnion, Lift, Lower
31	124526X	Button, Plunger
32	73220800	Nut, Hex, Fin. 1/2-13
33	121599X	Arm, Suspension, LH
34	12000022	E-Ring
35	73360700	Nut, Hex, Jam 7/16-20
36	74780624	Bolt, Hex 3/8-16 x 1-1/2
37	19292016	Washer 29/32 x 1-1/4 x 16 Gauge
38	73350600	Nut, Hex, Jam 3/8-16

NOTE: All component dimensions given in U.S. inches
1 inch = 25.4 mm

REPAIR PARTS

18 HP 44" TRACTOR - - MODEL NUMBER X1844A

44" MOWER DECK

KEY NO.	PART NO.	DESCRIPTION	KEY NO.	PART NO.	DESCRIPTION
1	73680600	Nut, Crownlock 3/8-16	39	19151616	Washer 15/32 x 1 x 16 Gauge
2	19131614	Washer 13/32 x 1 x 14 Gauge	40	19111016	Washer 11/32 x 5/8 x 16 Gauge
3	121316X	Pulley, Idler	41	19151610	Washer 15/32 x 1 x 10 Gauge
4	102403X	Pulley, Idler	42	106735X	Rod, Hinge
5	106902X	Spacer	43	106635X	Blade
6	677A451	Pulley, Idler	44	74610624	Bolt, Hex 3/8-24 x 1-1/2 Grade 5
7	106513X	Washer, Wear	45	19132012	Washer 13/32 x 1-1/4 x 12 Gauge
8	121425X	Arm, Idler	46	7631J	Runner, LH
9	76020412	Pin, Cotter 1/8 x 3/4	47	123807X	Bracket, Suspension, Rear, RH
10	106523X	Bar, Support, Idler	48	123808X	Bracket, Suspension, Rear, LH
11	106522X	Brace, Idler, Deck	49	109729X	Nose Roller
12	121236X	Spacer	50	109776X	Pin, Pivot
13	19131316	Washer 13/32 x 13/16 x 16 Gauge	51	72140614	Bolt, Carriage 3/8-16 x 1-3/4
14	136818	Mandrel, Secondary	52	72140608	Bolt, Carriage 3/8-16 x 1
15	106214X	Guard	53	72140612	Bolt, Carriage 3/8-16 x 1-1/2
16	106085X	V-Belt	54	74760620	Bolt, Hex 3/8-16 x 1-1/4
17	73220600	Nut, Hex 3/8-16	55	72140506	Bolt, Carriage 5/16-18 x 3/4
18	10030600	Washer, Lock 3/8	56	19111116	Washer 11/32 x 11/16 x 16 Gauge
19	102932X	Idler, Flat	57	73680500	Nut, Crownlock 5/16-18
20	106526X	Arm, Idler, Mower Deck	58	74760648	Bolt, Hex 3/8-16 x 3
21	7644J	Spring, Extension	59	74110632	Screw, Flat Head 3/8-16 x 2
22	121704X	Mandrel, Primary	60	72110505	Bolt, Carriage 5/16-18 x 5/8
23	74760616	Bolt, Hex 3/8-16 x 1	61	19111216	Washer 11/32 x 3/4 x 16 Gauge
24	109599X	Bracket, Lift, LH	62	74760580	Bolt, Hex 5/16-18 x 5
25	105662X	Link, Parallel	63	121352X	Keeper, Mandrel, LH
26	4921H	Retainer, Spring	64	19131210	Washer 13/32 x 3/4 x 10 Gauge
27	105744X	Pin, Front Hinge	65	19131410	Washer 13/32 x 7/8 x 10 Gauge
28	109835X	Pin, Rear Hinge	66	17490612	Screw, Hex Washer Head, Thd. Roll. 3/8-16 x 3/4
29	109600X	Bracket, Lift, RH	67	72140606	Bolt, Carriage 3/8-16 x 3/4
30	108119X	Guard, Belt, RH	68	102727X	Spring, Extension
31	10040600	Washer, Lock, Heavy Helical Spring	69	73930600	Nut, Centerlock 3/8-16
32	136321	Runner, RH	70	72110506	Bolt, Carriage 5/16-18 x 3/4
33	121423X	Housing, Mower	71	72140620	Bolt, Carriage 3/8-16 x 2-1/2
34	105304X	Cap, Sleeve	72	1685H	Nut, Crownlock 5/16-18
35	123713X	Spring	--	121826X	Mower Deck, Complete
36	110452X	Nut, Push			
37	137607	Bracket, Deflector			
38	109785X	Guard, Discharge			

NOTE: All component dimensions given in U.S. inches
1 inch = 25.4 mm

REPAIR PARTS

18 HP 44" TRACTOR - - MODEL NUMBER X1844A

TRANSAXLE PEERLESS - MODEL NUMBER 820-016B

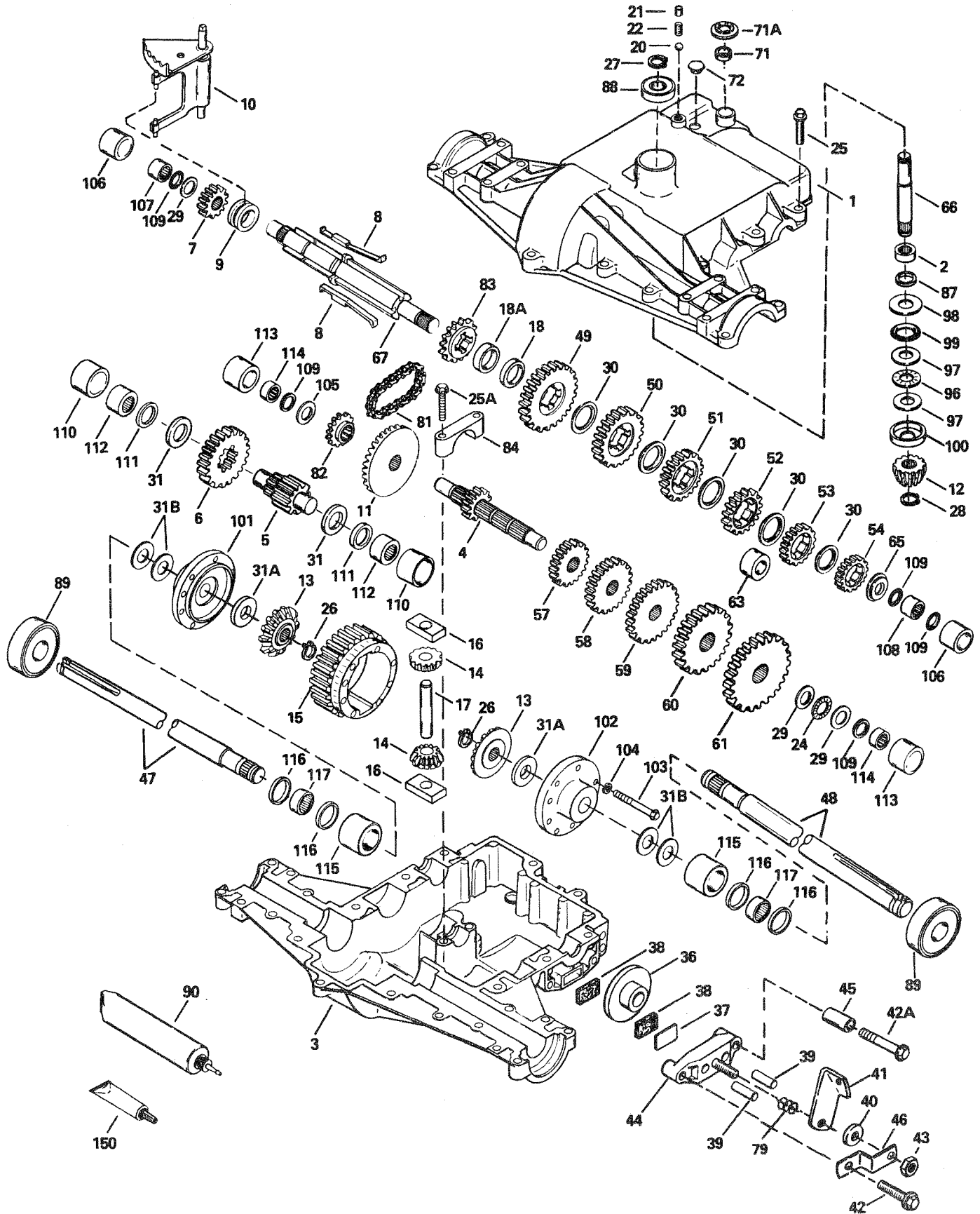

REPAIR PARTS

18 HP 44" TRACTOR - - MODEL NUMBER X1844A

TRANSAXLE PEERLESS - MODEL NUMBER 820-016B

REF PART NO. NO.	DESCRIPTION	REF PART NO. NO.	DESCRIPTION
-- 794513	Transaxle, Complete	53 778203A	Spur Gear, Steel, 22 Teeth
1 772098A	Transaxle Cover	54 778273	Spur Gear, Steel, 19 Teeth
2 780155	Needle Bearing	57 778136	Spur Gear, Steel, 15 Teeth
3 770088	Transaxle Case	58 778200	Spur Gear, Steel, 20 Teeth
4 776291	Countershaft and Gear, 9 Teeth	59 778201	Spur Gear, Steel, 25 Teeth
5 776275	Output Shaft	60 778202	Spur Gear, Steel, 28 Teeth
6 778247	Output Gear, Steel, 35 Teeth	61 778208	Spur Gear, Steel, 31 Teeth
7 778253	Spur Gear, Steel, 15 Teeth	65 780139	Washer
8 792138	Shift Key	66 776274	Input Shaft
9 784216	Shift Collar	67 776313	Shifter and Brake Shaft
10 784342	Shift Fork	71 788069	Square Cut Ring
11 778246	Bevel Gear, Steel, 33 Teeth	71A 792145	Pushnut
12 778245	Input Bevel Pinion, Steel, 13 Teeth	72 792074	Threaded Plug 9/16-18
13 778198	Bevel Gear, Steel, 16 Teeth	79 792144	Spring
14 778197	Bevel Pinion, Steel, 10 Teeth	81 786081	Roller Chain (Number 41 Chain, 24 Links)
15 778248	Ring Gear	82 786082	Sprocket, 9 Teeth
16 786027	Drive Block	83 786123	Reverse Sprocket, 18 Teeth
17 786019	Drive Pin	84 786131	Bearing Cap
18 786121	Neutral Spacer, .350/.340 Thick	87 788042	Oil Seal 3/4
18A 786122	Neutral Spacer, .276/.268 Thick	88 780119	Ball Bearing
20 792077	Steel Ball, 5/16" Diameter	89 780050	Ball Bearing
21 792078	Set Screw, 3/8-16 x 3/8"	90 788067B	Grease, Bentonite, 32 Ounce Bottle
22 792079	Spring	96 780084	Thrust Bearing
24 780071	Thrust Bearing	97 780051	Washer
25 792129	Screw 5/16-18 x 1-1/4"	98 780165	Washer
25A 792073	Screw 1/4-20 x 1-1/4"	99 788077	"O" Ring
26 792018	Retaining Ring	100 780166	Cupped Washer
27 792018	Retaining Ring	101 774833	Differential Carrier
28 788040	Retaining Ring	102 774834	Differential Carrier
29 780072	Washer	103 792020	Screw 1/4-20 x 2-1/4
30 780108	Washer	104 792006	Lock Washer
31 780128	Washer	105 780153	Washer
31A 780107	Washer	106 786144	Sleeve
31B 780042	Washer	107 780152	Needle Bearing
36 790043	Brake Disk	108 780150	Needle Bearing
37 790007	Brake Pad Plate	109 792001	"O" Ring
38 799021	Brake Pad (Package of 2)	110 786142	Sleeve
39 786026	Dowel Pin	111 788071	Square Cut Ring
40 792076A	Washer	112 780168	Needle Bearing
41 790047	Brake Lever	113 786143	Sleeve
42 792073	Screw 1/4-20 x 1-1/4	114 780151	Needle Bearing
42A 792085A	Screw 1/4-20 x 2-1/4	115 786145	Sleeve
43 792075	Locknut 5/16-24	116 788070	Square Cut Ring
44 790025	Brake Pad Holder	117 780031	Needle Bearing
45 786067	Spacer	150 510334	Gasket Eliminator (Loctite Number 515)
46 786086	Brake Lever Bracket		
47 774832	Axle, 12-5/16" Long		
48 774831	Axle, 16-3/16" Long		
49 778216A	Spur Gear, Steel, 41 Teeth		
50 778206A	Spur Gear, Steel, 35 Teeth		
51 778205A	Spur Gear, Steel, 30 Teeth		
52 778204A	Spur Gear, Steel, 25 Teeth		

Parts must be ordered from Tecumseh Products Co.

NOTE: All component dimensions given in U.S. inches
1 inch = 25.4 mm

SERVICE NOTES

SERVICE NOTES

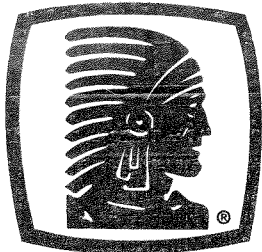

TECUMSEH

SERVICE POLICY WARRANTY

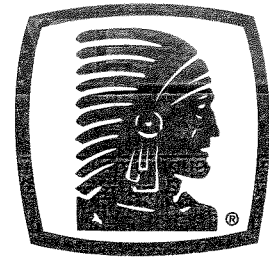

TECUMSEH

Issued January 1980
Revised January 1991

LIMITED WARRANTIES FOR NEW PEERLESS GEAR POWER TRAIN COMPONENTS

A. Products Warranted

Peerless Gear and Machine Division of Tecumseh Products Company ("Tecumseh"), subject to the limitations contained below, will, at its option, repair or replace, without charge for parts or labor only, any part of a new Power Train Component (which as used herein means and includes the transaxle, gear box, transmission, differential and right angle drives, and any part of the Power Train Component), EXCEPT any new Power Train Component incorporated in equipment used for commercial or rental purposes, which is found upon examination by any Tecumseh Authorized Service Outlet or by Tecumseh's factory in Grafton, Wisconsin, to be DEFECTIVE IN MATERIAL AND/OR WORKMANSHIP if received by Tecumseh or a Tecumseh Authorized Service Outlet for such examination within TWO YEARS from the date of sale to the original consumer purchaser of Peerless Series 820, 900, 910, 915, 920, 930 transaxles and Series 1100 angle drive and ONE YEAR for all other Peerless products. New Power Train Components incorporated in equipment used for commercial purposes are warranted in the same manner and to the same extent EXCEPT such Power Train Components are warranted for NINETY (90) DAYS ONLY, and must be received by Tecumseh or by a Tecumseh Authorized Service Outlet for such examination within 90 days from the date of sale to the original purchaser. New Power Train Components Incorporated in equipment used for rental purposes are warranted in the same manner and to the same extent EXCEPT such Power Train Components are warranted for THIRTY (30) DAYS ONLY, and must be received by Tecumseh or a Tecumseh Authorized Service Outlet within 30 days from the date of sale to the original purchaser.

B. Products And Items Not Warranted

1. Alterations or Modifications of Power Train Components.
 2. Accidents, Normal Maintenance, Failure to follow the Original Equipment Manufacturer's Manual.
- This warranty covers only parts of new Power Train Components which are found upon examination to be defective in material or workmanship as delivered to the original purchaser. This warranty does not cover defects caused by depreciation or damage caused by normal wear, accidents, improper maintenance, improper use or abuse of the product, failure to follow the instructions contained in an Instruction Manual for the operation of the Power Train Component and parts. The cost of normal maintenance and replacement of service items which are not defective shall be paid for by the original purchaser.

C. Securing Warranty Service

Warranty service can be arranged for by contacting either a Tecumseh Authorized Service Outlet (any Tecumseh Registered Service Dealer, Tecumseh Authorized Service Distributor, or Tecumseh Central Warehouse Distributor) or by contacting Tecumseh, c/o Service Manager, Engine and Transmission Group Service Division, 900 North Street, Grafton, Wisconsin 53024. Warranty service can only be performed by a Tecumseh Authorized Service Outlet or by Tecumseh at its factory in Grafton, Wisconsin. At the time of requesting warranty service, evidence must be presented of the date of sale to the original purchaser. The purchaser shall pay any charges for making service calls and/or for transporting the product to and from the place where the inspection and/or warranty work is performed. The purchaser shall be responsible for any damage or loss incurred in connection with the transportation of Power Train Components and/or part(s) of the Power Train Components submitted for inspection and/or warranty work.

D. Limitation of Damages and Implied Warranties

The foregoing EXPRESSED WARRANTY IS IN LIEU OF ALL OTHER EXPRESS WARRANTIES. Neither Tecumseh nor any of its affiliates makes any warranties, representations or promises, written or oral, as to the quality of the Power Train Component or any of its parts, other than as set forth herein.

ANY IMPLIED WARRANTY OF MERCHANTABILITY OR FITNESS FOR A PARTICULAR PURPOSE, TO THE EXTENT THAT EITHER MAY APPLY TO ANY PART(S) OF POWER TRAIN COMPONENTS, SHALL BE LIMITED IN DURATION TO THE PERIODS OF THE EXPRESSED WARRANTIES DEFINED IN PARAGRAPH A HEREOF. IN NO EVENT WILL TECUMSEH BE LIABLE FOR ANY INCIDENTAL, CONSEQUENTIAL OR SPECIAL DAMAGES AND/OR EXPENSES. Some states do not allow limitations on how long an implied warranty lasts or the exclusion or limitation of incidental or consequential damages, so the above limitation(s) or exclusion(s) may not apply to you. This warranty gives you specific legal rights and you may also have other legal rights which vary from state to state.

E. No Dealer Warranty

Tecumseh neither assumes nor authorizes any other person, natural or corporate, to assume for Tecumseh any other obligations or liabilities in connection with or with respect to any part(s) of a Power Train Component. The seller or dealer of part(s) of a Power Train Component has no authority, whatsoever, to make any representations or promises on behalf of Tecumseh or to modify the terms or limitations of Tecumseh's warranty in any way.

SUGGESTED GUIDE FOR SIGHTING SLOPES FOR SAFE OPERATION

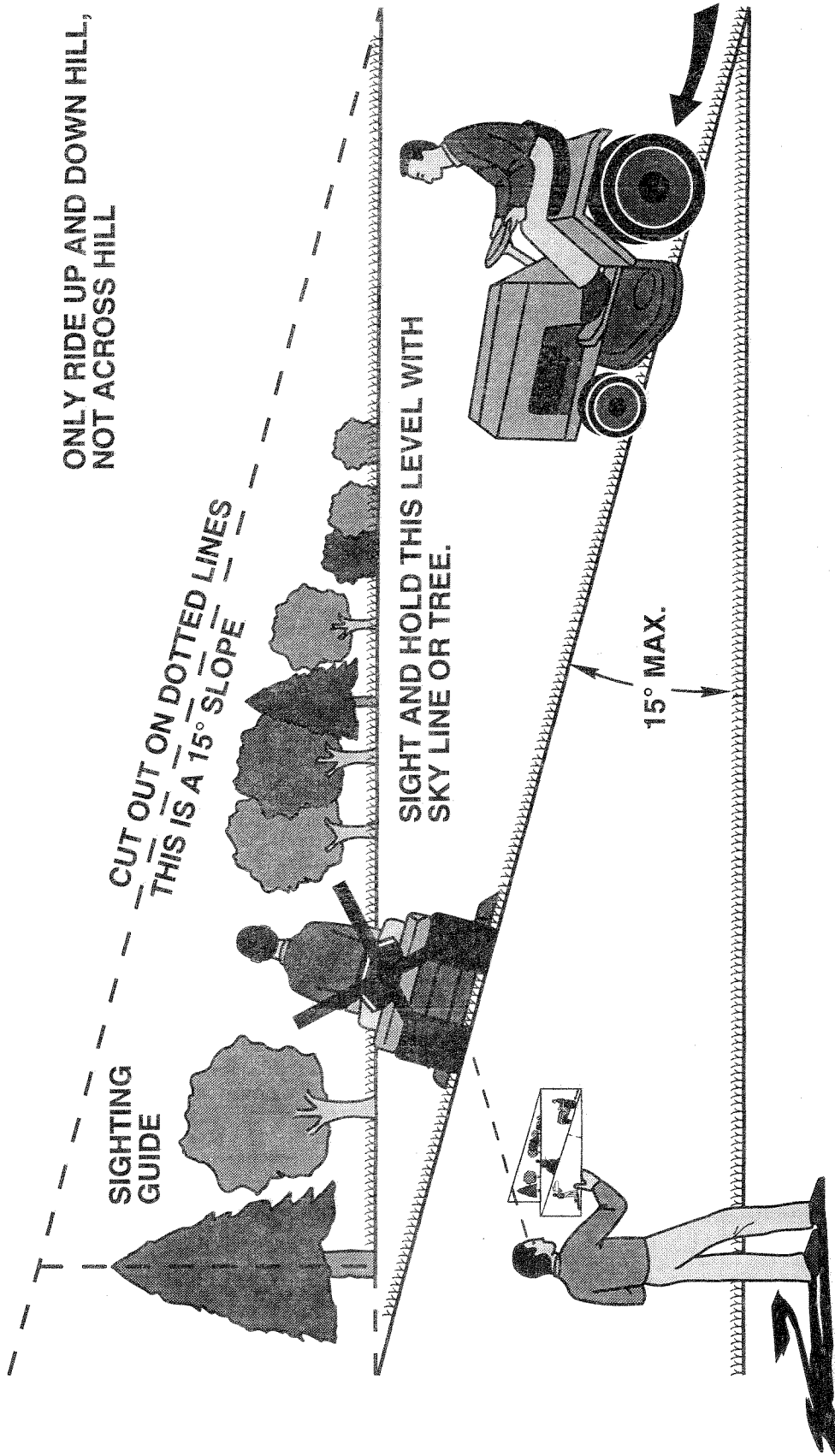

Operate your Tractor up and down the face of slopes (not greater than 15°), never across the face. Make turns gradually to prevent tipping or loss of control. Exercise extreme caution when changing direction on slopes.



Poulan

Download from Www.Somanuals.com. All Manuals Search And Download.

Free Manuals Download Website

<http://myh66.com>

<http://usermanuals.us>

<http://www.somanuals.com>

<http://www.4manuals.cc>

<http://www.manual-lib.com>

<http://www.404manual.com>

<http://www.luxmanual.com>

<http://aubethermostatmanual.com>

Golf course search by state

<http://golfingnear.com>

Email search by domain

<http://emailbydomain.com>

Auto manuals search

<http://auto.somanuals.com>

TV manuals search

<http://tv.somanuals.com>