

IMPORTANT MANUAL

Do Not Throw Away

Poulan®

FILE COPY

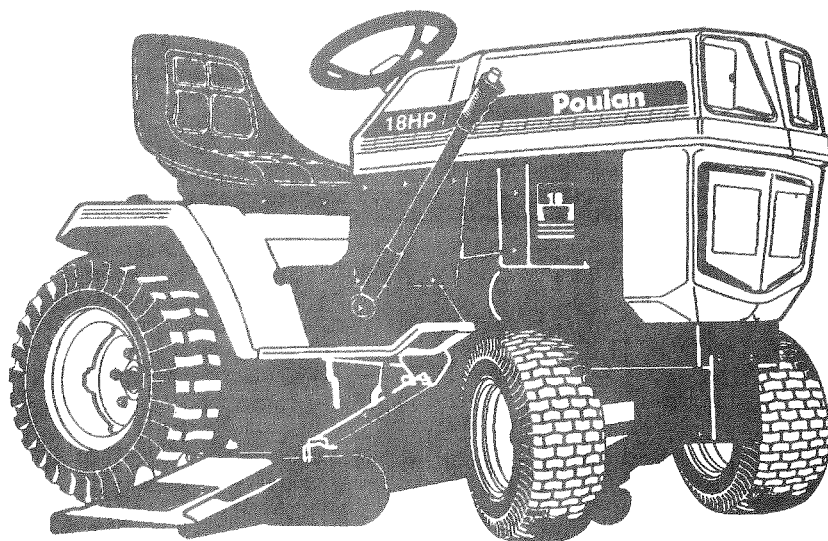

OPERATOR'S MANUAL

MODEL:

XC1182B

GARDEN TRACTOR

⚠ WARNING:

Carefully read the Operator's Manual and follow all Warnings and Safety Instructions. Failure to do so can result in serious injury.

Always Wear Eye Protection During Operation

POULAN/WEED EATER

DIVISION WHITE CONSOLIDATED INDUSTRIES, INC.

SAFETY RULES



CAUTION: ALWAYS DISCONNECT SPARK PLUG WIRE AND PLACE WIRE WHERE IT CAN NOT CONTACT SPARK PLUG TO PREVENT ACCIDENTAL STARTING WHEN SETTING UP, TRANSPORTING, ADJUSTING OR MAKING REPAIRS.



IMPORTANT

SAFETY STANDARDS REQUIRE OPERATOR PRESENCE CONTROLS TO MINIMIZE THE RISK OF INJURY. YOUR UNIT IS EQUIPPED WITH SUCH CONTROLS. DO NOT ATTEMPT TO DEFEAT THE FUNCTION OF THE OPERATOR PRESENCE CONTROLS UNDER ANY CIRCUMSTANCES.

TRAINING:

- Know the controls and how to stop quickly. Read this owner's manual and instructions furnished with attachments.
- Do not allow children to operate the machine. Do not allow adults to operate it without proper instruction.
- Do not carry passengers. Do not mow when children and others are around.
- Do not attempt to operate your vehicle or mower when not in the driver's seat.
- Always get on or off your vehicle from the operator's left hand side.
- The vehicle and attachments should be stopped and inspected for damage after striking a foreign object, and the damage should be repaired before restarting and operating the equipment.

PREPARATION:

- Always wear substantial footwear. Do not wear loose fitting clothing that could get caught in moving parts.
- Clear the work area of objects (wire, rocks, etc.) which might be picked up and thrown.
- Disengage all attachment clutches before attempting to start the engine.
- Handle gasoline with care – it is highly flammable.
 - Use approved gasoline containers.
 - Never remove the fuel cap of the fuel tank or add gasoline to a running or hot engine or an engine that has not been allowed to cool for several minutes after running. Never fill tank indoors. Always clean up spilled gasoline.
 - Open doors if the engine is run in the garage – exhaust fumes are dangerous. Do not run the engine indoors.
- Do not operate the mower without the entire grass catcher, on mowers so equipped, or the deflector shield in place.

OPERATION:

- Keep your eyes and mind on your vehicle, mower, and the area being cut. Do not let other interests distract you.
- Disengage power to attachments and stop the engine before leaving the operator's position.
- Disengage power to mower, stop the engine, and disconnect spark plug wire(s) from spark plug(s) before cleaning, making an adjustment, or repair. Be careful to avoid touching hot muffler or engine components.
- Disengage power to attachments when transporting or not in use.
- Take all possible precautions when leaving the vehicle unattended. Disengage the power take-off, lower the attachments, shift into neutral, set the parking brake, stop the engine, and remove the key.
- Do not stop or start suddenly when going uphill or downhill. Mow up and down the face of slopes (not greater than 15°), never across the face.
- Reduce speed on slopes and make turns gradually to prevent tipping or loss of control. Exercise extreme caution when changing direction on slopes.
- While going up or down slopes, place gearshift control lever in 1st gear position to negotiate the slope without stopping.

- Never mow in wet or slippery grass, when traction is unsure, or at a speed which could cause a skid.
- Stay alert for holes in the terrain and other hidden hazards. Keep away from drop-offs.
- Do not drive too close to creeks, ditches, and public highways.
- Exercise special care when mowing around fixed objects in order to prevent the blades from striking them. Never deliberately run vehicle or mower into or over any foreign objects.
- Never shift gears until vehicle comes to a stop.
- Never place hands or feet under the mower, in discharge chute, or near any moving parts while vehicle or mower is running. Always keep clear of discharge chute.
- Use care when pulling loads or using heavy equipment.
 - Use only approved drawbar hitch points.
 - Limit loads to those you can safely control.
 - Do not turn sharply. Use care when backing.
 - Use counterweight or wheel weights when suggested in owner's manual.
- Watch out for traffic when crossing or near roadways.
- When using any attachments, never direct discharge of material toward bystanders nor allow anyone near the vehicle while in operation.
- Except for adjustments, do not operate engine if air cleaner or cover directly over carburetor air intake is removed. Removal of such part could create a fire hazard.
- Do not change the engine governor settings or overspeed the engine; severe damage or injury may result.
- When using the vehicle with mower, proceed as follows:
 - Mow only in daylight or in good artificial light.
 - Shut the engine off when unclogging chute.
 - Check the blade mounting bolts for proper tightness at frequent intervals.
- Disengage power to mower before backing up. Do not mow in reverse unless absolutely necessary and then only after careful observation of the entire area behind the mower.
- Keep the vehicle and attachments in good operating condition, and keep safety devices in place and working.

MAINTENANCE AND STORAGE

- Keep all nuts, bolts, and screws tight to be sure the equipment is in safe working condition.
- Never store the equipment with gasoline in the tank inside a building where fumes may reach an open flame or spark. Allow the engine to cool before storing in any enclosure.
- To reduce fire hazard, keep the engine free of grass, leaves, or excessive grease. Do not clean product while engine is running.
- Do not operate without a muffler, or tamper with exhaust system. Damaged mufflers or spark arresters could create a fire hazard. Inspect periodically and replace if necessary.
- Under normal usage the grass catcher bag material is subject to deterioration and wear. It should be checked frequently for bag replacement. Replacement bags should be checked to ensure compliance with the original manufacturer's recommendations or specifications.



LOOK FOR THIS SYMBOL TO POINT OUT IMPORTANT SAFETY PRECAUTIONS. IT MEANS – ATTENTION!!! BECOME ALERT!!! YOUR SAFETY IS INVOLVED.

CONGRATULATIONS on your purchase of a new tractor. It has been designed, engineered and manufactured to give you the best possible dependability and performance.

If you should experience any problem you cannot easily remedy, please contact your nearest Authorized Service Facility. They have competent, well-trained technicians and the proper tools to repair this unit.

Please read and retain this manual. The instructions will enable you to assemble, operate, and maintain your unit properly. Always observe the "SAFETY RULES".

MODEL NUMBER	XC1182B
SERIAL NUMBER	_____
DATE OF PURCHASE	_____
THE MODEL AND SERIAL NUMBERS WILL BE FOUND ON A PLATE UNDER THE SEAT.	
YOU SHOULD RECORD BOTH SERIAL NUMBER AND DATE OF PURCHASE AND KEEP IN A SAFE PLACE FOR FUTURE REFERENCE.	

CUSTOMER RESPONSIBILITIES

- Read and observe the safety rules.
- Follow a regular schedule in maintaining, caring for and using your unit.
- Follow the instructions under "Maintenance" and "Storage" sections of this owner's manual.

PRODUCT SPECIFICATIONS

HORSEPOWER:	18.0
GASOLINE CAPACITY:	3.5 GALLONS UNLEADED REGULAR
OIL:	
4.0 PINTS (w/filter change)	SAE 30 (or 10W-30)
3.5 PINTS (w/o filter change)	WINTER: SAE 5W-30
SPARK PLUG (GAP.025 IN.):	CHAMPION RV15YC
GROUND SPEED:	
	1st .071 MPH
	2nd 1.05 MPH
	3rd 1.22 MPH
	4th 3.24 MPH
	5th 4.12 MPH
	6th 5.29 MPH
	Rev. 1.62 MPH
TIRE PRESSURE:	FRONT: 14 PSI REAR: 10 PSI
CHARGING SYSTEM:	15 AMPS @3600 RPM
BLADE BOLT TORQUE:	30-35 FT. LBS.

WARNING: This unit is equipped with an internal combustion engine and should not be used on or near any unimproved forest-covered, brush-covered or grass-covered land unless the engine's exhaust system is equipped with a spark arrester meeting applicable local or state laws (if any). If a spark arrester is used, it should be maintained in effective working order by the operator.

TABLE OF CONTENTS

SAFETY RULES	2	MAINTENANCE	15-18
PRODUCT SPECIFICATIONS	3	SERVICE AND ADJUSTMENTS	19-24
CUSTOMER RESPONSIBILITIES	3	STORAGE	25
WARRANTY	5	TROUBLESHOOTING	26-27
ASSEMBLY	7-10	WIRING SCHEMATIC	30
OPERATION	10-14	SLOPE SHEET	31

INDEX

A		Starting	14	Operating Mower	13
Adjustments:		Storage	25	Operation	11-14
Brake	21	F			
Carburetor	24	Filter:			
Mower:		Air Cleaner	18		
Front-To-Back	20	Fuel	18		
Side-To-Side	19	Oil	18		
Throttle Control Cable	24	Fuel:			
Air Filter, Engine	18	Storage	25		
Air Screen, Engine	18	Type	14		
Assembly	7-10	Fuse	23		
B		H			
Battery:		Headlights	23		
Charging	8	L			
Cleaning	17	Leveling Mower Deck	19-20		
Installation	10	Lubrication, Chart	15		
Levels	8,17	M			
Preparation	8	Maintenance	15-18		
Starting with Weak Battery	23	Air Filter	18		
Storage	25	Foam Pre-Cleaner	18		
Terminals	17	Air Screen, Engine	18		
Belt:		Battery	17		
Motion Drive:		Blade	16		
Removal/Replacement	22	Cooling Fins, Engine	18		
Mower Blade Drive:		Engine Oil	17		
Removal/Replacement	21	Fuel Filter	18		
Mower Drive:		Lubrication Chart	15		
Removal/Replacement	21	Schedule	15		
Blade:		Spark Plugs	18		
Replacement	16	Tire Care	8,16		
Sharpening	16	Mower:			
Brake Adjustment	21	Adjustment:			
C		Front-To-Back	20		
Carburetor, Adjustment	24	Side-To-Side	19		
Controls, Tractor	11	Blade Replacement	16		
Cutting Height, Mower	12	Blade Sharpening	16		
E		Cutting Height	12		
Engine:		Installation	9		
Adjustments:		Operation	13		
Carburetor	24	Removal	19		
Throttle Control Cable	24	Mowing Tips	14		
Air Filter	18	Muffler	18		
Air Screen	18	Spark Arrestor	3		
Cooling Fins	18	O			
Oil Change	17	Oil:			
Oil Filter	18	Cold Weather Conditions	13,17		
Oil Level	13,17	Engine	17		
Oil Type	17	Filter	18		
Preparation	13	P			
A					
S					
T					
W					

LIMITED WARRANTY

The Manufacturer warrants to the original consumer purchaser that this product as manufactured is free from defects in materials and workmanship. For a period of two (2) years from date of purchase by the original consumer purchaser, we will repair or replace, at our option, without charge for parts or labor incurred in replacing parts, any part which we find to be defective due to materials or workmanship. This Warranty is subject to the following limitations and exclusions.

1. This warranty does not apply to the engine, transaxle/transmission components, battery (except as noted below) or components parts thereof. Please refer to the applicable manufacturer's warranty on these items.
2. Transportation charges for the movement of any power equipment unit or attachment are the responsibility of the purchaser. Transportation charges for any parts submitted for replacement under this warranty must be paid by the purchaser unless such return is requested by Poulan/Weed Eater.
3. Battery Warranty: On products equipped with a Battery, we will replace, without charge to you, any battery which we find to be defective in manufacture, during the first year of ownership. After one year, we will exchange the Battery, charging you 1/12 of the price of a new Battery for each full month after one (1) year from the date of the original sale. Battery must be maintained in accordance with the instructions furnished.
4. The Warranty period for any products used for rental or commercial purposes is limited to 90 days from the date of original purchase.
5. This Warranty applies only to products which have been properly assembled, adjusted, operated, and maintained in accordance with the instructions furnished. This Warranty does not apply to any product which has been subjected to alteration, misuse, abuse, improper assembly or installation, delivery damage, or to normal wear of the product.
6. Exclusions: Excluded from this Warranty are belts, blades, blade adapters, normal wear, normal adjustments, standard hardware and normal maintenance.
7. In the event you have a claim under this Warranty, you must return the product to an authorized service dealer.

Should you have any unanswered questions concerning this Warranty, please contact:

Poulan/Weed Eater
549 Canada Avenue
Huron Park, Ontario
Canada N0M1Y0
Phone: (519) 228-6514

giving the model number, serial number and date of purchase of your product and the name and address of the authorized dealer from whom it was purchased.

THIS WARRANTY DOES NOT APPLY TO INCIDENTAL OR CONSEQUENTIAL DAMAGES AND ANY IMPLIED WARRANTIES ARE LIMITED TO THE SAME TIME PERIODS STATED HEREIN FOR OUR EXPRESSED WARRANTIES. Some areas do not allow the limitation of consequential damages or limitations of how long an implied Warranty may last, so the above limitations or exclusions may not apply to you. This Warranty gives you specific legal rights, and you may have other rights which vary from locale to locale.

This is a limited Warranty within the meaning of that term as defined in the Magnuson-Moss Act of 1975.

CONTENTS OF HARDWARE PACK

Parts Bag contents shown full size

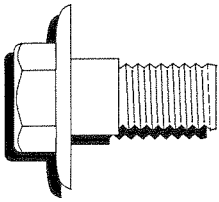

(1) Shoulder Bolt 5/16-18

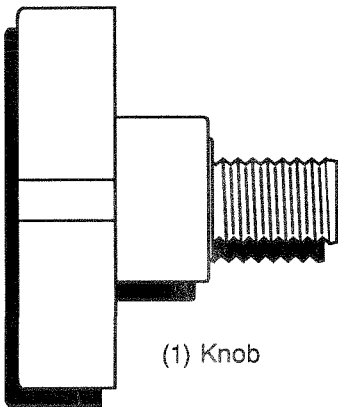

(1) Knob

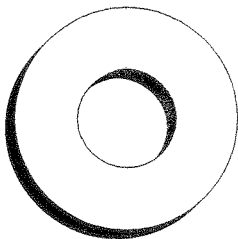

(1) Washer 17/32 x 1-3/16 x 12 Ga.



(2) Hex Bolts 1/4 - 20 x 3/4



(2) Hex Nuts 1/4 - 20



(2) Washers 9/32 x 5/8 x 16 Ga.



(2) Lockwashers 1/4



(2) Wing Nuts 1/4 - 20

Parts packed separately in carton

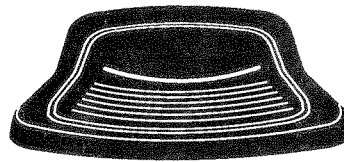

Seat

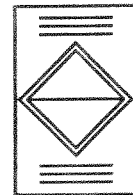

Battery acid

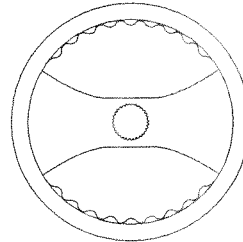

Steering Wheel

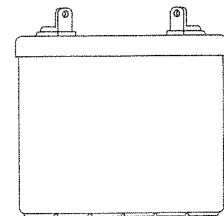

Battery

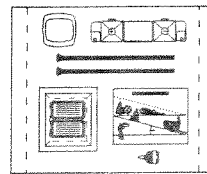

Parts Bag



Owner's Manual

Parts bag contents not shown full size



(2) Keys

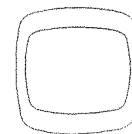

Steering Wheel Insert



(2) Battery Carriage Bolts 1/4-20 x 7-1/2

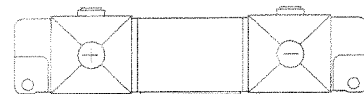

Terminal Guard

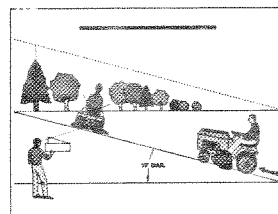

15° Slope Sheet

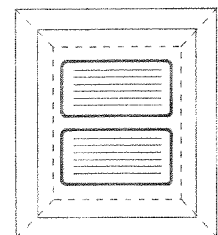

Battery Caps and Instructions

ASSEMBLY

TOOLS REQUIRED FOR ASSEMBLY

A socket wrench set will make assembly easier. Standard wrench sizes are listed.

- (2) 7/16" wrenches
- (1) Tire Pressure Gauge
- (1) Adjustable Wrench
- (1) Utility Knife

When right or left hand is mentioned in this manual, it means when you are in the operating position (seated behind the steering wheel).

TO REMOVE UNIT FROM CARTON

UNPACK CARTON

- Remove all loose parts from carton (See page 6).
- Cut, from top to bottom, all four corners of carton and lay panels flat.
- Remove mower deck from skid.

ATTACH STEERING WHEEL (See FIG. 1)

- Remove hex nut and large flat washer from steering shaft.
- Position front wheels of the tractor so they are pointing straight forward.
- Position steering wheel so cross bars are horizontal (left to right) and slide onto adapter.
- Secure steering wheel to steering shaft with hex nut and large flat washer previously removed. Tighten securely.
- Snap insert into center of steering wheel.
- Remove protective plastic from tractor hood.

BEFORE ROLLING UNIT OFF SKID (See FIG. 2)

IMPORTANT: CHECK FOR AND REMOVE ANY STAPLES IN SKID THAT MAY PUNCTURE TIRES WHERE UNIT IS TO ROLL OFF SKID.

- Raise attachment lift lever to its highest position.
- Release parking brake by depressing clutch/brake pedal.
- Place gearshift lever in "NEUTRAL" position.
- Roll unit backwards off skid.

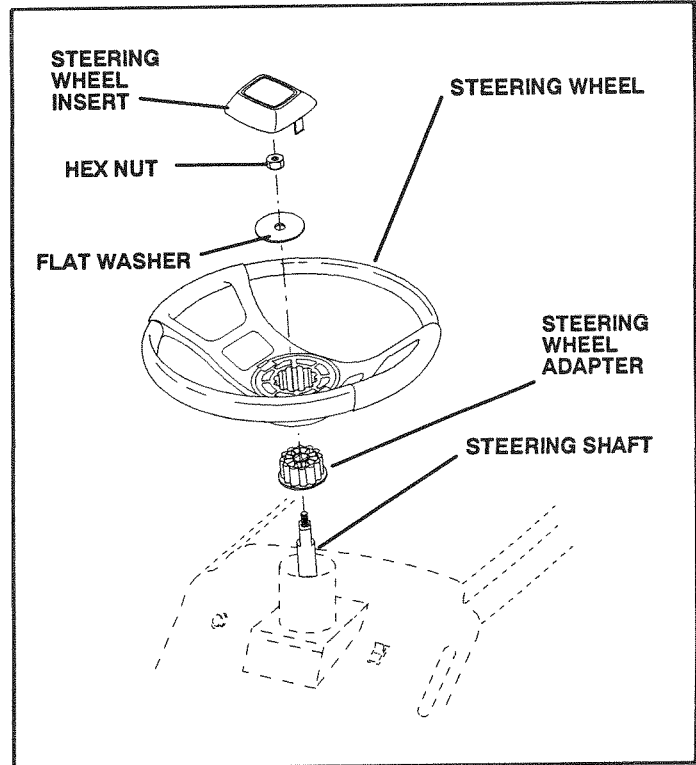

FIG. 1

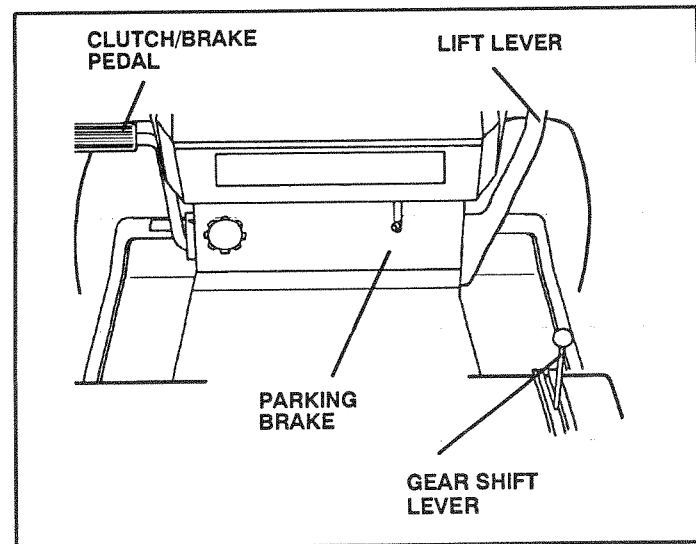

FIG. 2

ASSEMBLY

HOW TO SET UP YOUR TRACTOR

PREPARE BATTERY (See FIG. 3)



CAUTION: Wear eye and face shield.

Wash hands or clothing immediately if accidentally in contact with battery acid.

Do not smoke. Fumes from charged battery acid are explosive.

Read the instructions included with the battery vent caps in the bag of parts. Always wear gloves, clothing and goggles to protect your hands, skin and eyes.

Your unit has a battery charging system which is sufficient for normal use. However, periodic charging of the battery with an automotive charger will extend its life.

- See instructions packed with vent caps in parts bag.
- Fill battery with acid. Fill each cell until it reaches the bottom of the vent wells. Do not over fill.
- Allow battery to stand and settle for at least thirty minutes. After standing, check the level of acid. If below the vent wells, add more acid until the correct level is reached.

While battery is standing (after adding acid) and later, while battery is being charged, continue with assembly of unit.

- To maximize the life of your battery, it is necessary that the battery be charged before use. Use a 12 volt battery charger. Charge battery at a rate of 6 amperes for 1 hour. Observe all safety precautions required for battery charging. Failure to charge battery can result in a shortened battery life.
- Check the acid level after the battery is charged. If the acid has fallen below the correct level, add distilled or iron free water.
- Install the vent caps to cover the vent wells. Wash the top of the battery with water to remove any acid, then wipe dry.
- Check battery case for leakage to make sure that no damage has occurred in handling.
- Dispose of excess battery acid. Neutralize acid for disposal by adding it to four inches of water in a five gallon plastic container. Stir with a wooden or plastic paddle while adding baking soda until the addition of more soda causes no more foaming.
- Follow instructions on how to install battery.

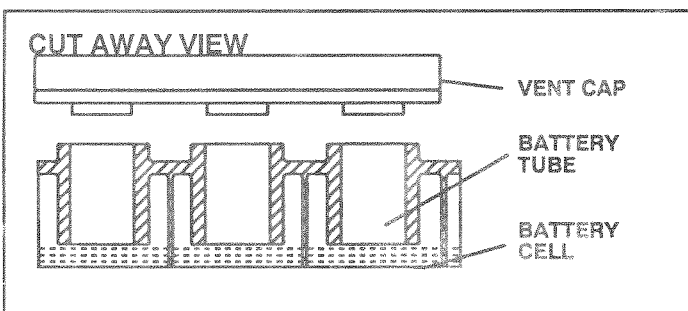

FIG. 3

INSTALL SEAT (See FIG. 4)

Adjust seat before tightening adjustment knob.

- Remove cardboard packing on seat pan.
- Place seat on pan and assemble shoulder bolt.
- Assemble adjustment knob and flat washer loosely. Do not tighten.
- Tighten shoulder bolt securely.
- Lower seat into operating position and sit on seat.
- Slide seat until a comfortable position is reached which allows you to press clutch/brake pedal all the way down.
- Get off seat without moving its adjusted position.
- Raise seat and tighten adjustment knob securely.

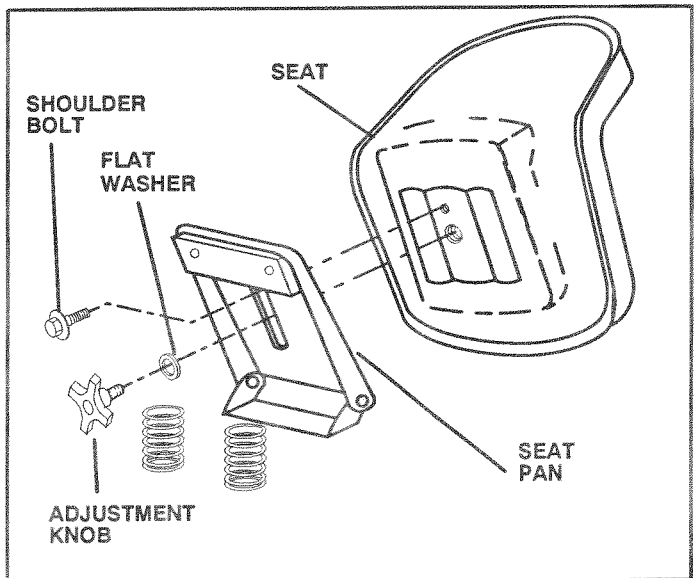

FIG. 4

CHECK TIRE PRESSURE

The tires on your unit were overinflated at the factory for shipping purposes. Correct tire pressure is important for best cutting performance.

- Reduce tire pressure to PSI shown in "PRODUCT SPECIFICATIONS" on page 3 of this manual.

CHECK BRAKE SYSTEM

After you learn how to operate your tractor, check to see that the brake is properly adjusted. See "TO ADJUST BRAKE" in the Service and Adjustments section of this manual.

ASSEMBLY

INSTALL MOWER (See FIGS. 5, 6, 7 & 8)

Your unit has been shipped with the mower parallel link included in the parts carton. Install mower parallel link on unit using short hinge pin and retainer spring.

NOTE: Smaller end of parallel link mounts to tractor. Use the shortest hinge pin for mounting.

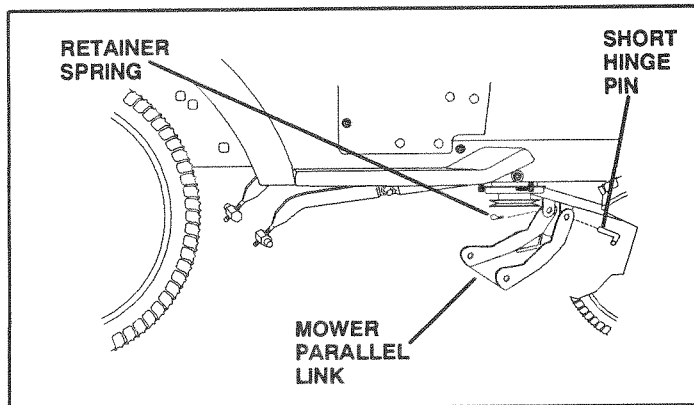

FIG. 5

- Raise attachment lift lever to its highest position.
- Remove banding from suspension arms.
- Slide mower under tractor with discharge guard to right side of tractor.
- Attach front of mower to parallel link with long hinge pin. Secure hinge pin with retainer spring.
- Turn height adjustment knob to its lowest setting.
- Lower attachment lift lever to lower suspension arms. Remove retainer springs from lift trunnions.
- Slide trunnions through upper lift bracket holes and secure with retainer springs.
- Pull L.H. idler pulley toward the right hand side of tractor and roll belt over electric clutch pulley.

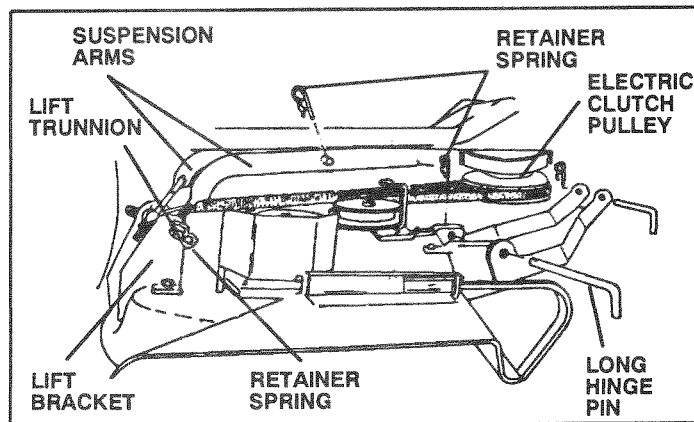

FIG. 6

NOTE: Mower drive belt installation decal located on mower housing.

- Raise attachment lift lever to raise mower.
- Turn height adjustment knob clockwise to the middle of its travel.

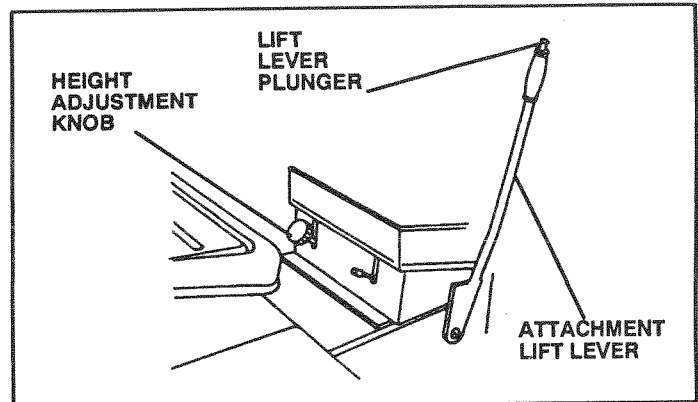

FIG. 7

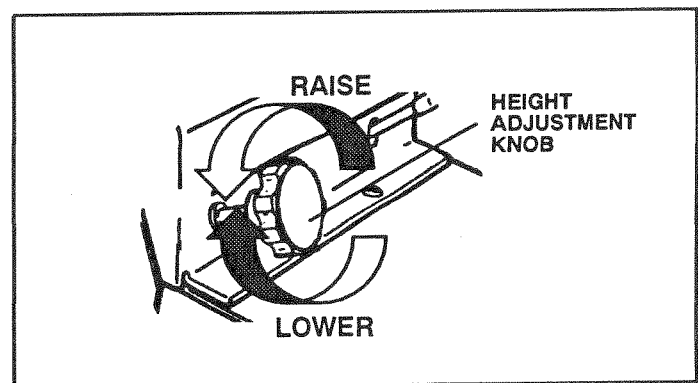

FIG. 8

CHECK DECK LEVELNESS

For best cutting results, mower housing should be properly leveled. See "TO LEVEL MOWER HOUSING" in the Service and Adjustments section of this manual.

CHECK FOR PROPER POSITION OF ALL BELTS

See the figures that are shown for replacing motion, mower drive, and mower blade drive belts in the Service and Adjustments section of this manual. Verify that the belts are routed correctly.

CHECK BRAKE SYSTEM

After you learn how to operate your tractor, check to see that the brake is properly adjusted. See "TO ADJUST BRAKE" in the Service and Adjustments section of this manual.

ASSEMBLY

INSTALL BATTERY (See FIGS. 9 & 10)



CAUTION: Do not short battery terminals. Before installing battery, remove metal bracelets, wristwatch bands, rings, etc.

Positive terminal must be connected first to prevent sparking from accidental grounding.

- Raise hood.
- Make sure drain tube is fastened to drain hole in battery tray and battery tray is positioned in hole of battery support.
- Place battery in plastic tray, battery terminals to front of tractor.
- First connect RED battery cable to positive (+) battery terminal with hex bolt, flat washer, lockwasher and hex nut as shown. Tighten securely.
- Connect BLACK grounding cable to negative (-) battery terminal with remaining hex bolt, flat washer, lockwasher and hex nut. Tighten securely.
- Slide the two battery bolts through terminal guard and start wing nuts onto threads.
- Position terminal guard over battery as shown, lower bolts into key holes and slide square shafts of bolts into slots of key holes.
- Tighten wing nuts by hand making sure battery bolts remain in slots of key holes in battery support.
- Be sure terminal access doors are closed.

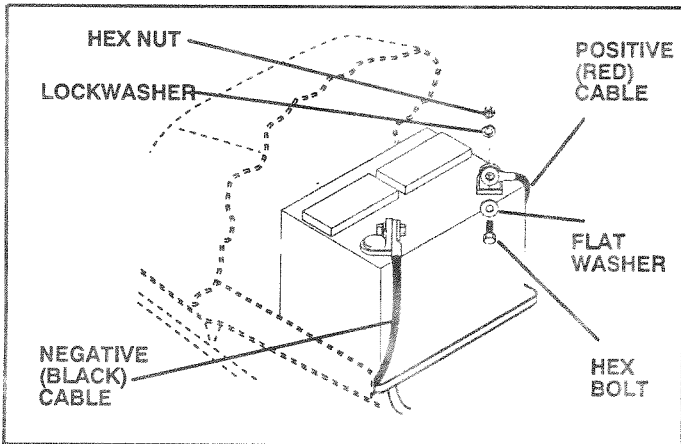

FIG. 9

Use terminal access doors for:

- Inspection for secure connections (to tighten hardware)
- Inspection for corrosion
- Testing battery
- Jumping (if required)
- Periodic charging

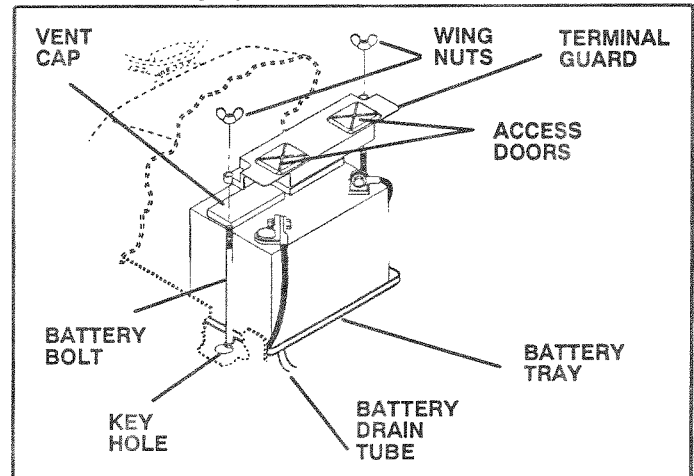

FIG. 10

✓ CHECKLIST

BEFORE YOU OPERATE AND ENJOY YOUR NEW TRACTOR, WE WISH TO ASSURE THAT YOU RECEIVE THE BEST PERFORMANCE AND SATISFACTION FROM THIS QUALITY PRODUCT.

PLEASE REVIEW THE FOLLOWING CHECKLIST:

- ✓ All assembly instructions have been completed.
- ✓ No remaining loose parts in carton.
- ✓ Battery is properly prepared and charged. (Minimum 1 hour at 6 amps).
- ✓ Seat is adjusted comfortably and tightened securely.
- ✓ All tires are properly inflated. (For shipping purposes, the tires were overinflated at the factory.)
- ✓ Be sure mower deck is properly leveled side-to-side/ front-to-rear for best cutting results. (Tires must be properly inflated for leveling.)
- ✓ Check mower and drive belts. Be sure they are routed properly around pulleys and inside all belt keepers.
- ✓ Check wiring. See that all connections are still secure and wires are properly clamped.

WHILE LEARNING HOW TO USE YOUR TRACTOR, PAY EXTRA ATTENTION TO THE FOLLOWING IMPORTANT ITEMS:

- ✓ Engine oil is at proper level.
- ✓ Fuel tank is filled with fresh, clean, regular unleaded gasoline.
- Become familiar with all controls – their location and function. Operate them before you start the engine.
- ✓ Be sure brake system is in safe operating condition.

OPERATION

KNOW YOUR TRACTOR

READ THIS OWNER'S MANUAL AND SAFETY RULES BEFORE OPERATING YOUR TRACTOR.

Compare the illustrations with your Tractor to familiarize yourself with the locations of various controls and adjustments. Save this manual for future reference.

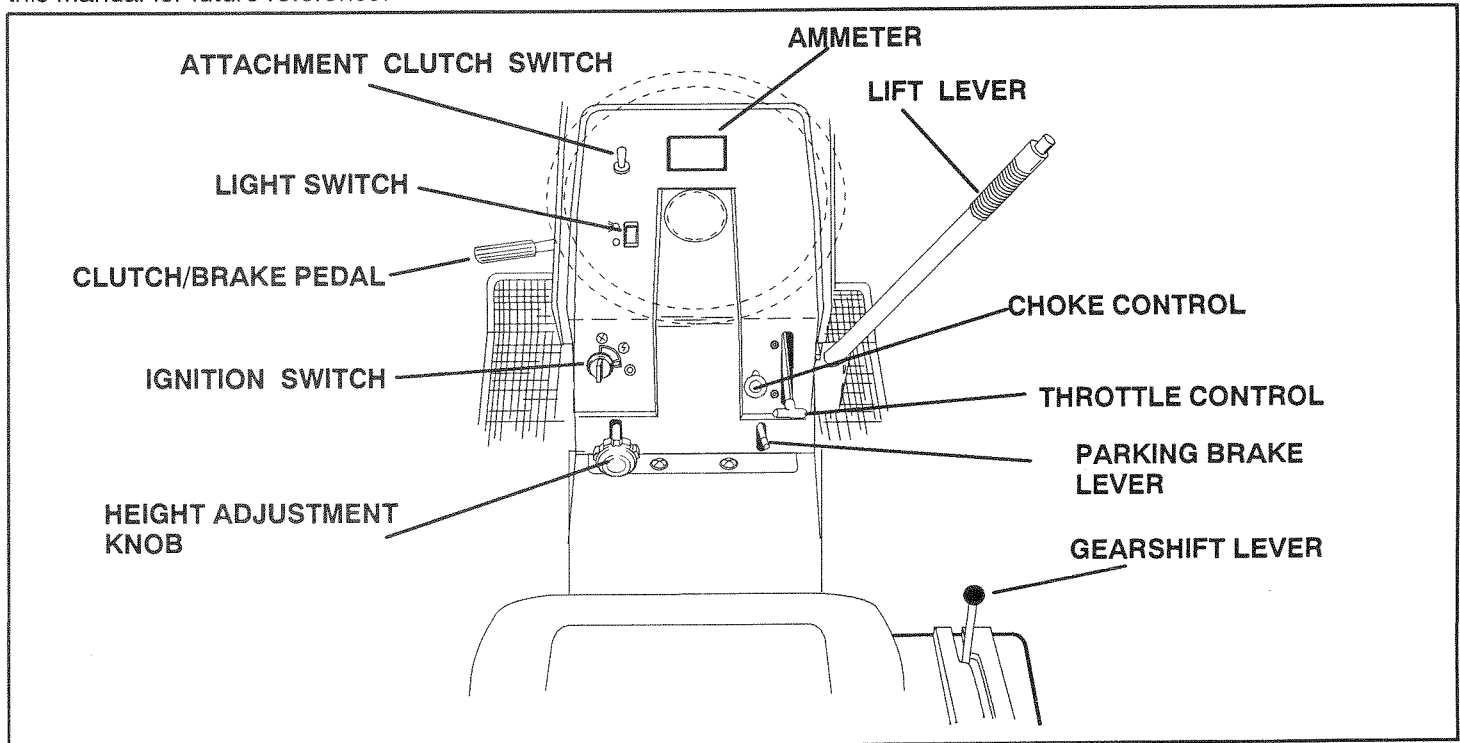

FIG. 11

ATTACHMENT CLUTCH SWITCH – Used to engage mower blades or other attachments mounted to your tractor.

LIFT LEVER – Used to raise and lower mower deck or other attachments mounted to your tractor.

CLUTCH/BRAKE PEDAL – Used for declutching and braking the tractor.

HEIGHT ADJUSTMENT KNOB – Used to adjust the mower height.

GEARSHIFT LEVER – Selects the speed and direction of the tractor.

THROTTLE CONTROL – Used to control engine speed.

IGNITION SWITCH – Used to start and stop the engine.

AMMETER – Indicates battery charging (+) or discharging (-).

LIGHT SWITCH – Turns the headlights on and off.

PARKING BRAKE LEVER – Locks clutch/brake pedal into the brake position.

CHOKE CONTROL – Used when starting a cold engine.

CAUTION TO AVOID INJURY

- READ OWNER'S MANUAL.
- KNOW LOCATION AND FUNCTION OF ALL CONTROLS.
- KEEP GUARDS, SAFETY SHIELDS AND SWITCHES IN PLACE AND WORKING.
- REMOVE OBJECTS THAT CAN BE THROWN BY BLADES.
- DO NOT MOW WHEN CHILDREN AND OTHERS ARE AROUND.
- NEVER CARRY CHILDREN OR PASSENGERS.
- ALWAYS LOOK BEHIND MACHINE BEFORE BACKING.
- DO NOT MOW WHERE MACHINE CAN TIP OR SLIP.
- IF MACHINE STOPS GOING UPHILL, STOP BLADE AND BACK DOWN SLOWLY.
- BE SURE BLADES AND ENGINE HAVE STOPPED BEFORE PLACING HANDS OR FEET NEAR THE BLADES.
- REMOVE KEY WHEN LEAVING MACHINE.

OPERATION



The operation of any tractor can result in foreign objects thrown into the eyes, which can result in severe eye damage. Always wear safety glasses or eye shields while operating your tractor or before performing any adjustments or repairs. We recommend wide vision safety mask for over the spectacles or standard safety glasses.

HOW TO USE YOUR TRACTOR

TO SET PARKING BRAKE (See FIG. 12)

- Depress clutch/brake pedal into full "BRAKE" position and hold.
- Place parking brake lever in "ENGAGED" position and release pressure from clutch/brake pedal. Pedal should remain in "BRAKE" position. Make sure parking brake will hold vehicle secure.

STOPPING (See FIG. 12)

MOWER BLADES –

- Move attachment clutch switch to "DISENGAGED" position.

GROUND DRIVE –

- Depress clutch/brake pedal into full "BRAKE" position.
- Move gearshift lever to "NEUTRAL" position.

ENGINE –

- Move throttle control to "SLOW" position.
- Turn ignition key to "OFF" position and remove key. Always remove key when leaving vehicle to prevent unauthorized use.
- Never use choke to stop engine.

TO USE CHOKE CONTROL (See FIG. 12)

Use choke control whenever you are starting a cold engine. Do not use to start a warm engine.

- To engage choke control, pull knob out. Slowly push knob in to disengage.

TO USE THROTTLE CONTROL (See FIG. 12)

Always operate engine at full throttle.

- Operating engine at less than full throttle reduces the battery charging rate and the engine cooling air flow.
- Full throttle offers the best mower performance.

TO MOVE FORWARD AND BACKWARD (See FIG. 12)

The direction and speed of movement is controlled by the gear shift lever.

- Start unit with clutch/brake pedal depressed and the gearshift lever in "NEUTRAL" position.
- Move gearshift lever to desired position.
- Slowly release clutch/brake pedal to start movement.

IMPORTANT: BRING TRACTOR TO A COMPLETE STOP BEFORE SHIFTING OR CHANGING GEARS.

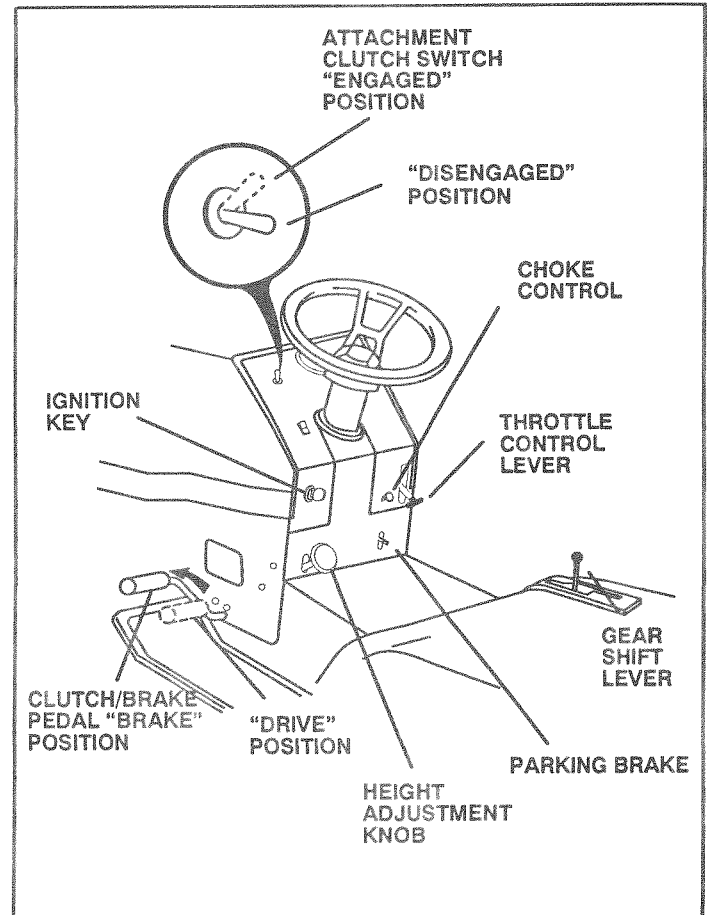

FIG. 12

TO ADJUST MOWER CUTTING HEIGHT (See FIG. 12)

The cutting height is controlled by turning the height adjustment knob in desired direction.

- Turn knob clockwise to raise cutting height.
- Turn knob counterclockwise to lower cutting height.

The cutting height range is approximately (1–1/4" to 3–3/4"). The heights are measured from the ground to the blade tip with the engine not running. These heights are approximate and may vary depending upon soil conditions, height of grass and types of grass being mowed.

- The average lawn should be cut approximately 2–1/2 inches during the cool season and over 3 inches during hot months. For healthier and better looking lawns, mow often and after moderate growth.

For best cutting performance, grass over 6 inches in height should be mowed twice. Make the first cut relatively high; the second to desired height.

OPERATION

TO OPERATE MOWER (See FIGS. 11 and 12)

Your unit is equipped with an operator presence sensing switch. Any attempt by the operator to leave the seat with the engine running and the attachment clutch engaged will shut off the engine.

- Select desired height of cut, using height adjustment knob.
- Lower mower with lift lever.
- Engage mower by pulling attachment clutch switch up and out to "ENGAGED" position.
- TO STOP MOWER – Move attachment clutch switch to "DISENGAGED" position.
- Raise mower with lift lever.



CAUTION: Do not operate the mower without either the entire grasscatcher, on mowers so equipped, or the discharge guard in place.

TO OPERATE ON HILLS



CAUTION: Do not drive up or down hills with slopes greater than 15° and do not drive across any slope.

- Choose the slowest speed before starting up or down hills.
- Avoid stopping or changing speeds on hills.
- If slowing is necessary, move throttle control lever to slower position.
- If stopping is absolutely necessary, push clutch/brake pedal quickly to brake position and engage parking brake.
- Move gearshift lever to "NEUTRAL" position.
- To restart movement, move gearshift lever to 1st gear and range shift lever to "LO" position. Be sure you have allowed room for unit to roll slightly as you restart movement.
- Slowly release parking brake and clutch/brake pedal.
- Make all turns slowly.

TO TRANSPORT

- Raise attachment lift control to highest position.
- When pushing or towing your unit, be sure gearshift lever is in "NEUTRAL" position.
- Do not push or tow unit at more than five (5) MPH.

BEFORE STARTING THE ENGINE

CHECK ENGINE OIL LEVEL (See FIG. 13)

- The engine in your unit has been shipped, from the factory, already filled with summer weight oil.
- Check engine oil with unit on level ground.
- Remove dipstick and wipe clean, replace, wait for a few seconds, remove and read oil level. If necessary, add oil until "FULL" mark on dipstick is reached. Do not overfill.
- For cold weather operation you should change oil for easier starting (see "OIL VISCOSITY CHART" in the Maintenance section of this manual).
- To change engine oil, see the Maintenance section in this manual.

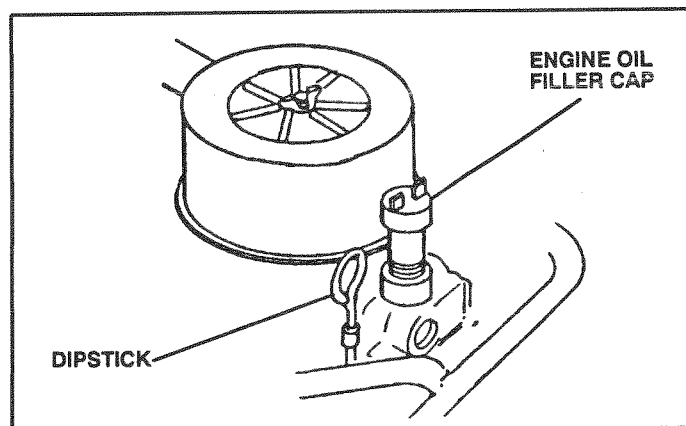

FIG. 13

ADD GASOLINE

- Fill fuel tank. Use fresh, clean, regular unleaded gasoline. (Use of leaded gasoline will increase carbon and lead oxide deposits and reduce valve life).

IMPORTANT: WHEN OPERATING IN TEMPERATURES BELOW 32°F (0°C), USE FRESH CLEAN WINTER GRADE GASOLINE TO HELP INSURE GOOD COLD WEATHER STARTING.

WARNING: Experience indicates that alcohol blended fuels (called gasohol or using ethanol or methanol) can attract moisture which leads to separation and formation of acids during storage. Acidic gas can damage the fuel system of an engine while in storage. To avoid engine problems, the fuel system should be emptied before storage of 30 days or longer. Drain the gas tank, start the engine and let it run until the fuel lines and carburetor are empty. Use fresh fuel next season. See Storage sections of this manual for additional information. Never use engine or carburetor cleaner products in the fuel tank or permanent damage may occur.



CAUTION: Fill to bottom of gas tank filler neck. Do not overfill. Wipe off any spilled oil or fuel. Do not store, spill or use gasoline near an open flame.

OPERATION

TO START ENGINE (See FIG. 12)

When starting engine for the first time or if engine has run out of fuel, it will take extra cranking time to move fuel from the tank to the engine.

- Depress the clutch/brake pedal and set the parking brake.
- Place gearshift lever in "NEUTRAL" position.
- Move attachment clutch to "DISENGAGED" position.
- Pull choke control out to "CHOKE" position for cold engine start. For warm engine start do not use choke control.
- Move throttle control to midway between "FAST" and "SLOW" positions.
- Turn ignition key clockwise to "START" position and release key as soon as engine starts. Do not run starter continuously for more than fifteen seconds per minute. If engine does not start after several attempts, move throttle control to "FAST" position, wait a few minutes and try again.
- When engine starts, slowly push choke control in.
- Move throttle control to "FAST" position.
- Allow engine to warm up for a few minutes before engaging clutch/brake pedal or attachment clutch switch.

NOTE: If at a high altitude (above 3000 feet) or in cold temperatures (below 32° F), the carburetor fuel mixture may need to be adjusted for best engine performance. See "TO ADJUST CARBURETOR" in the Service and Adjustments section of this manual.



CAUTION: Before driving the tractor, install mower or remove front mower suspension bracket and suspension arms.

MOWING TIPS

- Tire chains cannot be used when the mower housing is attached to unit.
- Mower should be properly leveled for best mowing performance. See "TO LEVEL MOWER HOUSING" in the Service and Adjustments section of this manual.
- Use the runner on the right hand side of mower as a guide. The blade cuts approximately an inch outside the runner (See FIG. 14).

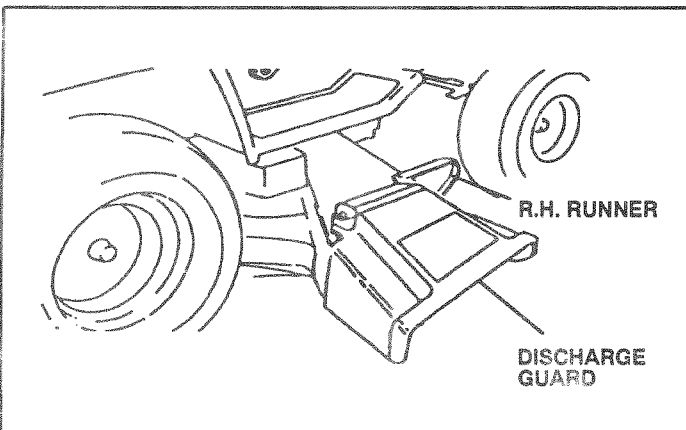

FIG. 14

- The left hand side of mower should be used for trimming.
- Drive so that clippings are discharged onto the area that has been cut. Have the cut area to the right of the machine. This will result in a more even distribution of clippings and more uniform cutting.
- When mowing large areas, start by turning to the right so that clippings will discharge away from shrubs, fences, driveways, etc. After one or two rounds, mow in the opposite direction making left hand turns until finished (See FIG. 15).

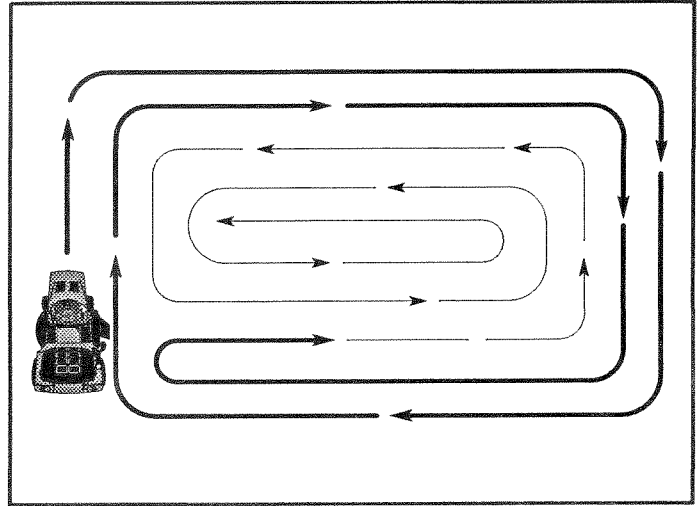

FIG. 15

- If grass is extremely tall, it should be mowed twice to reduce load and possible fire hazard from dried clippings. Make first cut relatively high, the second to the desired height.
- Do not mow grass when it is wet. Wet grass will plug mower and leave undesirable clumps. Allow grass to dry before mowing.
- Always operate engine at full throttle when mowing to assure better mowing performance and proper discharge of material. Regulate ground speed by selecting a low enough gear to give the mower cutting performance as well as the quality of cut desired.
- When operating attachments, select a ground speed that will suit the terrain and give best performance of the attachment being used.

MAINTENANCE

MAINTENANCE SCHEDULE		BEFORE EACH USE FIRST 2 HOURS EVERY 8 HOURS EVERY 25 HOURS EVERY 50 HOURS EVERY 100 HOURS EVERY SEASON BEFORE STORAGE							SERVICE DATES	
FILL IN DATES AS YOU COMPLETE REGULAR SERVICE										
T R A C T O R	Check Brake Operation	✓	✓							
	Check Tire Pressure	✓	✓							
	Check for Loose Fasteners	✓						✓		
	Sharpen/Replace Mower Blades				✓ ³					
	Lubricate Pivot Points				✓			✓		
	Check Battery Level/Recharge				✓					
	Clean Battery and Terminals				✓			✓		
E N G I N E	Check Engine Oil Level	✓								
	Change Engine Oil		✓		✓ ^{1,2}		✓			
	Clean Air Filter/Foam Pre-cleaner				✓ ²					
	Clean Air Screen				✓ ²					
	Inspect Muffler/Spark Arrester				✓					
	Change Engine Oil Filter						✓ ^{1,2}	✓		
	Clean Engine Cooling Fins						✓ ²			
	Replace Spark Plug						✓	✓		
	Replace Air Filter Paper Cartridge						✓ ²			
	Replace Fuel Filter							✓		

- 1 - Change more often when operating under a heavy load or in high ambient temperatures.
- 2 - Service more often when operating in dirty or dusty conditions.
- 3 - Replace blades more often when mowing in sandy soil.

GENERAL RECOMMENDATIONS

The warranty on this unit does not cover items that have been subjected to operator abuse or negligence. To receive full value from the warranty, operator must maintain unit as instructed in this manual.

Some adjustments will need to be made periodically to properly maintain your unit.

All adjustments in the Service and Adjustments section of this manual should be checked at least once each season.

- Once a year you should replace the spark plug, clean or replace air filter, and check blades and belts for wear. A new spark plug and clean air filter assure proper air-fuel mixture and help your engine run better and last longer.

BEFORE EACH USE

- Check engine oil level.
- Check brake operation.
- Check tire pressure.
- Check for loose fasteners.

LUBRICATION

Keep unit well lubricated (See "LUBRICATION CHART")

LUBRICATION CHART

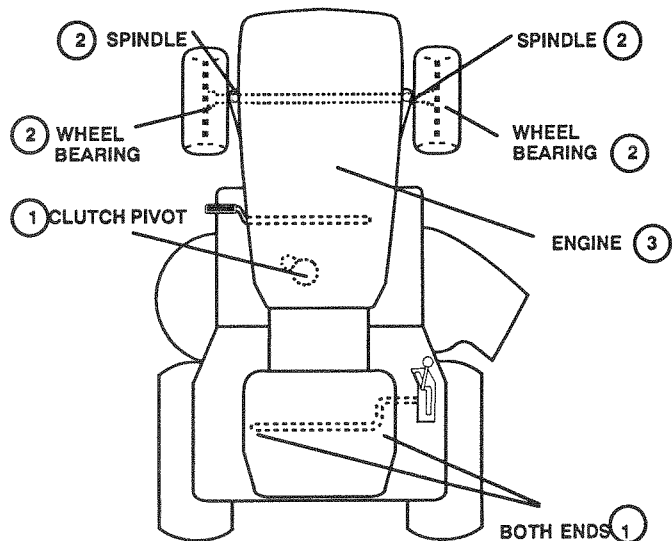

- ① SAE 30 OR 10W30 MOTOR OIL
- ② GENERAL PURPOSE GREASE
- ③ REFER TO ENGINE MAINTENANCE SECTION

IMPORTANT: Do not oil or grease the pivot points which have special nylon bearings. Viscous lubricants will attract dust and dirt that will shorten the life of the self-lubricating bearings. If you feel they must be lubricated, use only a dry, powdered graphite type lubricant sparingly.

MAINTENANCE

TRACTOR

Always observe safety rules when performing any maintenance.

TIRES

- Maintain proper air pressure in all tires (See "PRODUCT SPECIFICATIONS" on page 3 of this manual).
- Keep tires free of gasoline, oil, or insect control chemicals which can harm rubber.
- Avoid stumps, stones, deep ruts, sharp objects and other hazards that may cause tire damage.

BLADE CARE

For best results mower blades must be kept sharp. The blades can be sharpened with a file or on a grinding wheel. We suggest they be sharpened or replaced after every 25 hours of mowing. Check blades more often if mowing in sandy conditions.

- Do not attempt to sharpen blades while they are on the mower.
- Replace bent or damaged blades.

BLADE REMOVAL (See FIG. 16)

- Raise mower to highest position to allow access to blades.
- Remove hex bolt, lockwasher and flat washer securing blade.
- Install new or resharpened blade with trailing edge up towards deck as shown.
- Reassemble hex bolt, lockwasher and flat washer in exact order as shown.
- Tighten bolt securely (30–35 Ft. Lbs. torque).

IMPORTANT: BLADE BOLT IS GRADE 5 HEAT TREATED.

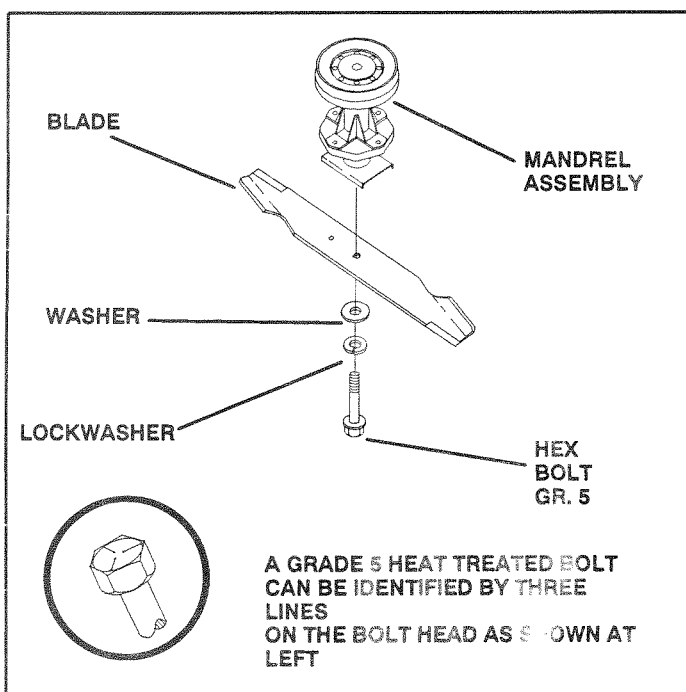

FIG. 16

TO SHARPEN BLADE (See FIG. 17)

Care should be taken to keep the blade balanced. An unbalanced blade will cause excessive vibration and eventual damage to mower and engine.

- The blade can be sharpened with a file or on a grinding wheel. Do not attempt to sharpen while on the mower.
- To check blade balance, drive a nail into a beam or wall. Leave about one inch of the straight nail exposed. Place center hole of blade over the head of the nail. If blade is balanced, it should remain in a horizontal position. If either end of the blade moves downward, sharpen the heavy end until the blade is balanced.

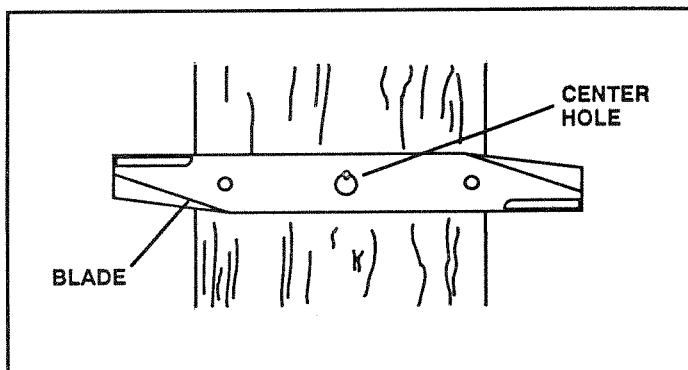

FIG. 17

MAINTENANCE

BATTERY (See FIG. 18)

Your unit has a battery charging system which is sufficient for normal use. However, periodic charging of the battery with an automotive charger will extend its life.

- Acid solution level in each battery cell should be even with bottoms of vent wells. Add only distilled or iron-free water if necessary. Do not overfill.

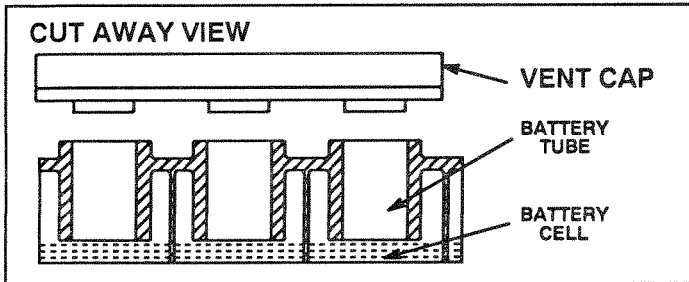

FIG. 18

- Keep battery and terminals clean.
- Keep battery bolts tight.
- Keep vent caps tight and small vent holes in caps open.
- Recharge at 6 amperes for 1 hour.

TO CLEAN BATTERY AND TERMINALS –

Corrosion and dirt on the battery and terminals can cause the battery to "leak" power.

- Remove terminal guard.
- Disconnect BLACK battery cable first then RED battery cable and remove battery from tractor.
- Wash battery with solution of four tablespoons of baking soda to one gallon of water. Be careful not to get the soda solution into the cells.
- Rinse the battery with plain water and dry.
- Clean terminals and battery cable ends with wire brush until bright.
- Coat terminals with grease or petroleum jelly.
- Reinstall battery (See "INSTALL BATTERY" in the Assembly section of this manual).

ENGINE

LUBRICATION

Change the oil after the first two hours of operation and every 50 hours thereafter or at least once a year if the tractor is not used for 50 hours in one year.

Check the crankcase oil level before starting the engine and after each five (5) hours of continuous use. Add SAE 30W motor oil or equivalent. Tighten oil fill cap/dipstick securely each time you check the oil level. SAE 5W-30 motor oil may be used to make starting easier in areas where temperature is consistently 32° F or lower.

TO CHANGE ENGINE OIL (See FIGS. 19 and 20)

Determine temperature range expected before oil change. All oil must meet API service classification SF/CC.

- Be sure vehicle is on level surface.
- Oil will drain more freely when warm.
- Catch oil in a suitable container.
- See engine manual packed with your unit for further instructions.

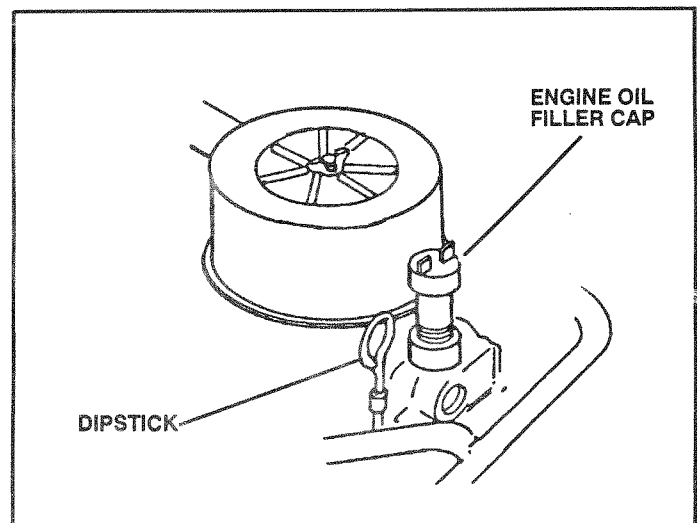

FIG. 19

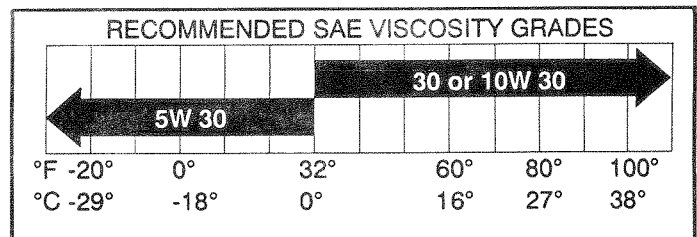

FIG. 20

MAINTENANCE

ENGINE

CLEAN AIR SCREEN

Air screen must be kept free of dirt and chaff to prevent engine damage from overheating. Clean with a brush or compressed air to remove dirt, stubborn dried gum fibers.

CLEAN ENGINE COOLING FINS

Remove any dust, dirt or oil from engine cooling fins to prevent damage from overheating. Air guide covers must be removed.

See Engine Manual packed with your unit.

AIR FILTER FOAM PRE-CLEANER

Your engine will not run properly and may be damaged by using a dirty air filter. Clean the foam pre-cleaner element after every 25 hours of operation, more often if tractor is used in very dusty, dirty conditions.

See Engine Manual packed with your unit.

ENGINE OIL FILTER

Replace the engine oil filter every season or every other oil change if the tractor is used more than 100 hours in one year.

See Engine Manual packed with your unit.

MUFFLER

Inspect and replace corroded muffler and spark arrester (if equipped) as it could create a fire hazard and/or damage.

SPARK PLUGS

Replace spark plugs at the beginning of each mowing season or after every 100 hours of use, whichever comes first. Spark plug type and gap setting is shown in "PRODUCT SPECIFICATIONS" on page 3 of this manual.

IN-LINE FUEL FILTER (See FIG. 21)

Fuel filter should be replaced once each season. If fuel filter becomes clogged, obstructing fuel flow to carburetor, replacement is required.

- With engine cool, remove filter and plug fuel line sections.
- Place new fuel filter in position in fuel line with arrow pointing towards carburetor.
- Be sure there are no fuel line leaks and clamps are properly positioned.
- Immediately wipe up any spilled gasoline.

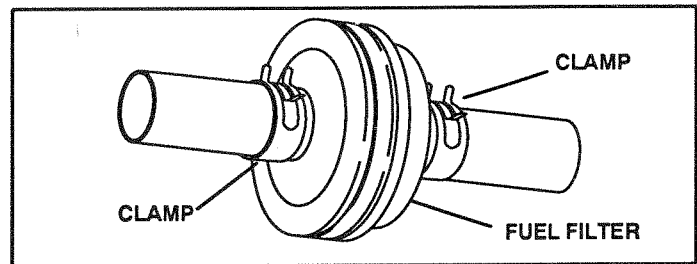

FIG. 21

CLEANING

- Clean engine, battery, seat, finish, etc. of all foreign matter.
- Keep finished surfaces and wheels free of all gasoline, oil, etc.
- Protect painted surfaces with automotive type wax.

We do not recommend using a garden hose to clean your unit unless the electrical system, muffler, air filter and carburetor are covered to keep water out. Water in engine can result in a shortened engine life.

SERVICE AND ADJUSTMENTS



CAUTION: BEFORE PERFORMING ANY SERVICE OR ADJUSTMENTS:

- Depress clutch/brake pedal fully and set parking brake.
- Place gear shift lever in "NEUTRAL" position.
- Place attachment clutch in "DISENGAGED" position.
- Turn ignition key "OFF" and remove key.
- Make sure the blades and all moving parts have completely stopped.
- Disconnect spark plug wire from spark plug and place wire where it cannot come in contact with plug.

TRACTOR

TO REMOVE MOWER (See FIG. 22)

Mower will be easier to remove from the right side of unit.

- Remove mower drive belt from electric clutch pulley only (See "TO REPLACE MOWER DRIVE BELT" through step removing belt from electric clutch pulley).
- Pull retainer springs out of rear suspension trunnions. Remove rear suspension trunnions from lift brackets.
- Pull retainer springs from front hinge pins.
- Remove hinge pins attaching parallel link to mower and front axle.
- Raise lift lever to raise suspension arms. Slide mower out from under tractor.

IMPORTANT: IF AN ATTACHMENT OTHER THAN THE MOWER IS TO BE MOUNTED TO THE TRACTOR, THE R.H. AND L.H. SUSPENSION ARMS MUST BE REMOVED FROM TRACTOR.

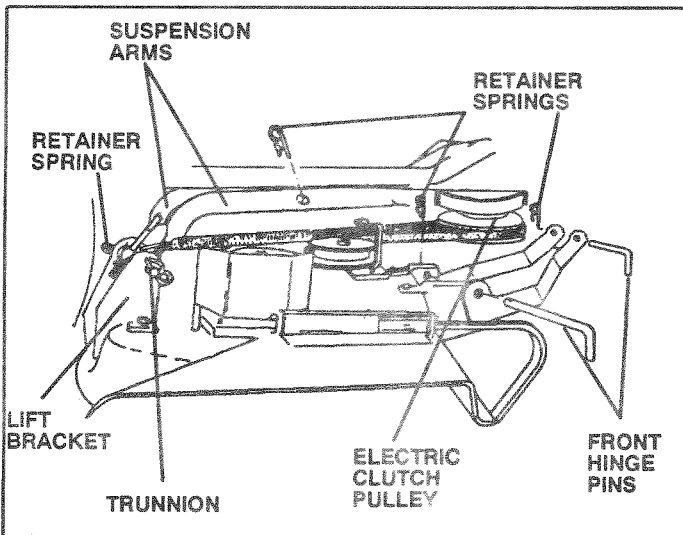

FIG. 22

TO INSTALL MOWER

See "INSTALL MOWER" in the assembly section of this manual.

TO LEVEL MOWER HOUSING

Adjust the mower while tractor is parked on level ground or driveway. Make sure tires are properly inflated (See "PRODUCT SPECIFICATIONS" on page 3). If tires are over or underinflated, you will not properly adjust your mower.

SIDE-TO-SIDE ADJUSTMENT (See FIGS. 23 and 24)

- Raise attachment lift lever to its highest position.
- Measure height from bottom of deck curl to ground level at front corners of mower. Distance "A" should be the same.

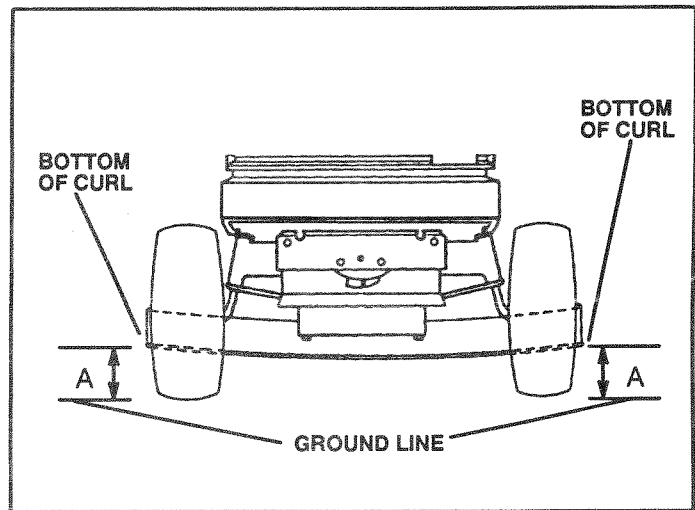

FIG. 23

- If distance "A" needs to be changed, snap out access hole cover on left side of tractor above footrest.
- To raise left side of mower, loosen nut "B" and tighten nut "C".
- To lower left side of mower, loosen nut "C" and tighten nut "B".
- When distance "A" is equal, securely tighten nuts "B" and "C".

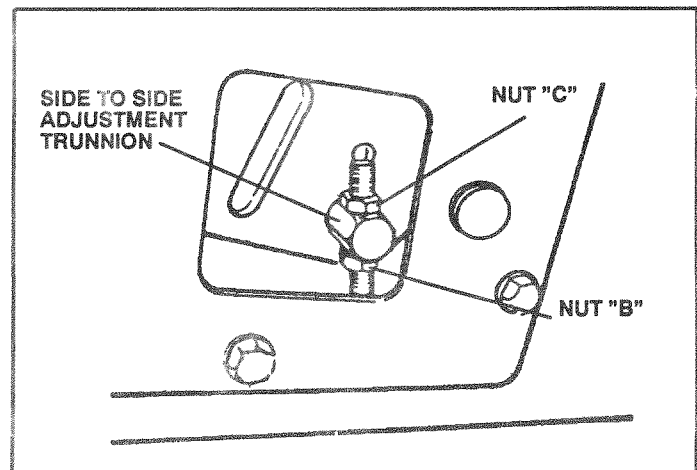

FIG. 24

- Replace access hole cover.

SERVICE AND ADJUSTMENTS

FRONT-TO-BACK ADJUSTMENT (See FIGS. 25 and 26)

To obtain the best cutting results, the mower housing should be adjusted so the rear is approximately 7/8" to 1-1/8" higher than the front when the mower is in its highest position.

Measure distance "D" from ground line to bottom of deck curl at centerline of mandrels.

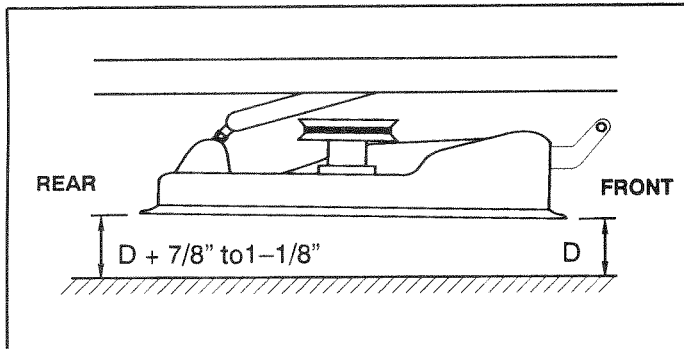

FIG. 25

- To raise rear of mower, loosen nut "E" on both rear suspension arms. Screw both nuts "F" on both rear suspension arms an equal number of turns.
- When distance "D" is 7/8" to 1-1/8" higher at rear than front, retighten nuts "E".

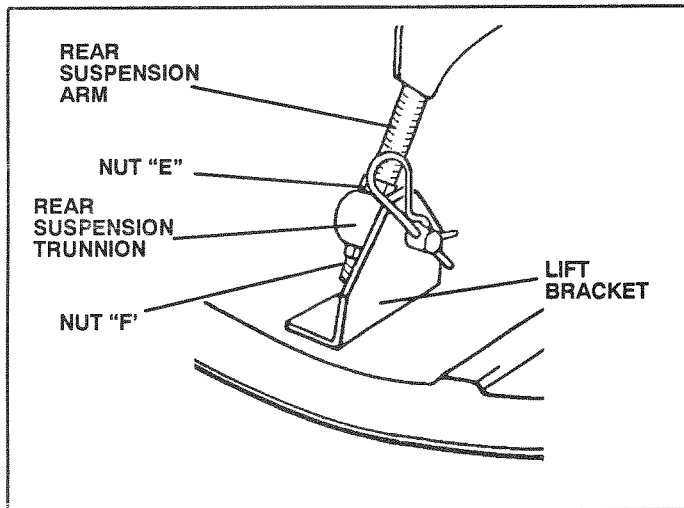

FIG. 26

- Recheck side-to-side adjustment.

IMPORTANT: WHEN ADJUSTING REAR SUSPENSION TRUNNIONS, ALWAYS ADJUST BOTH EQUALLY SO MOWER WILL STAY LEVEL SIDE-TO-SIDE.

TO ADJUST ATTACHMENT CLUTCH (See FIG. 27)

The electric clutch should provide years of service. The clutch has a built-in brake that stops the pulley within 5 seconds. Eventually, the internal brake will wear so the mower blades will not stop as recommended. Adjustments should be made by an authorized service technician.

- Make sure attachment clutch and ignition switches are in the "OFF" position.
- Adjust the three nylon lock nuts until the space between the clutch plate and the rotor, measures .012 inches at all three slot locations cut in the side of the brake plate.

NOTE: After installing a new electric clutch. Run tractor at full throttle, and engage and disengage electric clutch 10 cycles to wear in clutch plate.

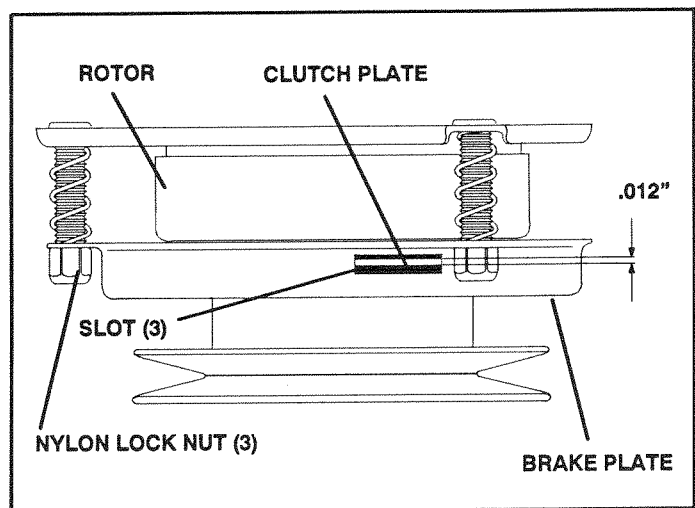

FIG. 27

SERVICE AND ADJUSTMENTS

TO REPLACE MOWER DRIVE BELT (See FIGS. 28 and 29)

The mower drive belt may be replaced without tools. Park the tractor on level surface. Engage parking brake. For assistance, there is a belt installation guide decal on the mower housing.

BELT REMOVAL –

- Place attachment clutch in “DISENGAGED” position.
- Turn height adjustment knob to lowest setting.
- Move attachment lift lever forward to lower mower to its lowest position.
- Roll belt off electric clutch pulley (See FIG. 22).

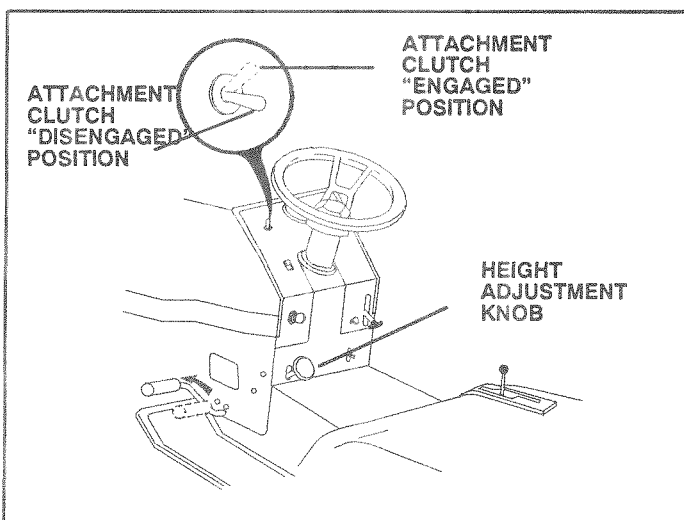

FIG. 28

- Pull belt off mower pulley and both idler pulleys.

BELT INSTALLATION –

- Place belt around mower pulley and both idler pulleys.
- Roll belt over electric clutch pulley.
- Make sure belt is in all pulley grooves and inside all belt guides.

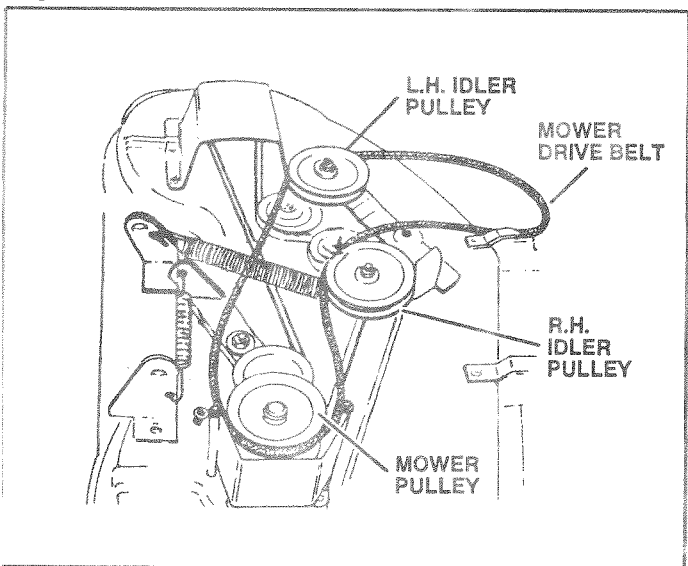

FIG. 29

TO ADJUST BRAKE (See FIG. 30)

Your unit is equipped with an adjustable brake system which is mounted on the right side of the transaxle.

If unit requires more than six (6) feet stopping distance at high speed in highest gear, then brake must be adjusted.

- Depress clutch/brake pedal and engage parking brake.
- Measure distance between brake operating arm and nut “A” on brake rod.
- If distance is other than 1–1/2”, disengage parking brake, loosen jam nut and turn nut “A” until distance becomes 1–1/2”. Retighten jam nut against nut “A”.
- Engage parking brake and recheck distance.
- Road test unit for proper stopping distance as stated above. Readjust if necessary. If stopping distance is still greater than six (6) feet in highest gear, further maintenance is necessary. Contact your nearest authorized service center.

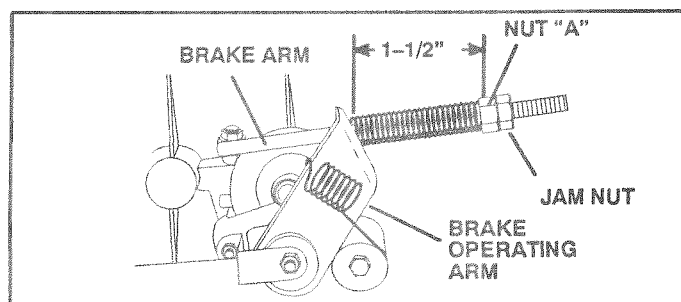

FIG. 30

TO REPLACE MOWER BLADE DRIVE BELT (See FIGS. 29 & 31)

- Remove mower (See “TO REMOVE MOWER” in this section of this manual).
- Pull mower drive belt off mower pulley and both idler pulleys.
- Pull mower blade drive belt towards rear of mower at tensioning pulley. Place a block between tensioning pulley and mower lift bracket. Roll belt off tensioning pulley.
- Roll belt off all other pulleys.
- Slide belt from under spring.
- To install belt, reverse above procedure. Make sure belt is engaged in all pulleys.

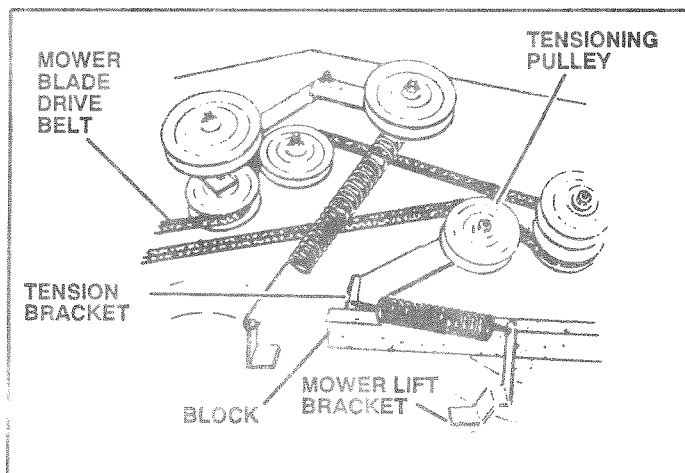

FIG. 31

SERVICE AND ADJUSTMENTS

TO REPLACE MOTION DRIVE BELT (See FIG. 32)

Park the tractor on level surface. Engage parking brake. For ease of service there is a belt installation guide decal on bottom side of left footrest.

- Remove mower (See "TO REMOVE MOWER" in this section of this manual).
- Remove the clutch locator.
- Loosen bolt securing R.H. belt keeper.
- Disconnect clutch wire harness.
- Pull belt off clutching idler and raise to top side of pulley.
- Release parking brake. Push belt over and away from clutching idler.
- Pull belt slack toward rear of tractor. Remove belt from transmission pulley by deflecting keepers to force belt up and out of pulley. Use belt to push keepers away from pulley.
- Work belt around remaining pulleys and keepers, working toward transaxle pulley.
- Pull belt forward off of transaxle pulley and down over electric clutch.
- Install new belt by reversing above procedure.

IMPORTANT: MAKE SURE RIGHT HAND BELT KEEPER IS POSITIONED CORRECTLY BETWEEN LOCATOR TABS, AND ELECTRIC CLUTCH CONNECTION IS SECURE.

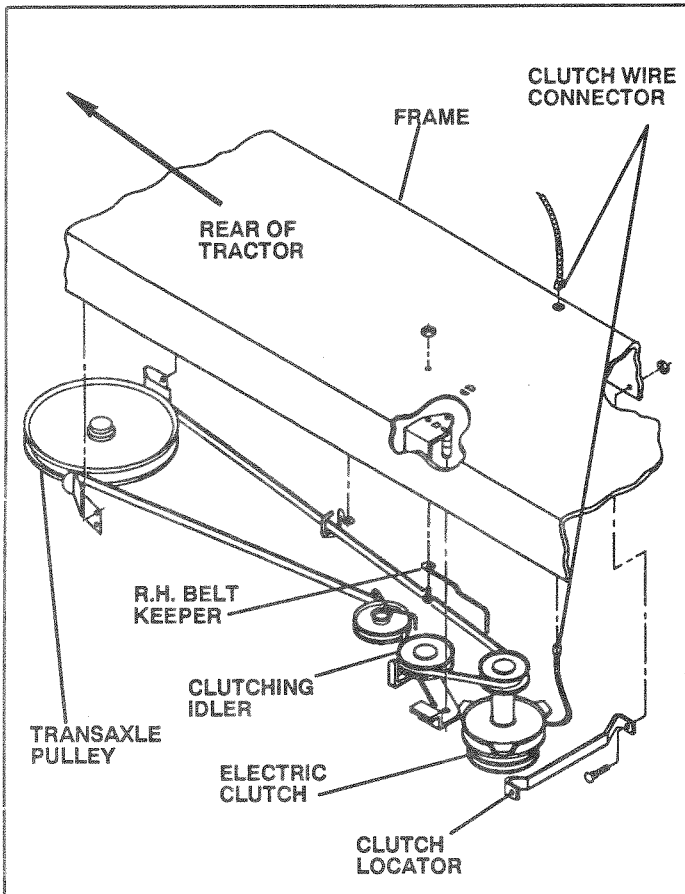

FIG. 32

TRANSAXLE SHIFTER LINKAGE AND ADJUSTMENT (See FIGS. 33 and 34)

The transaxle should be in neutral when the gear shift lever is in the neutral (lock gate) position. The adjustment is preset at the factory; however, if adjustment is needed, proceed as follows.

- Make sure transaxle is in neutral.
- Loosen two locknuts on tie rod.

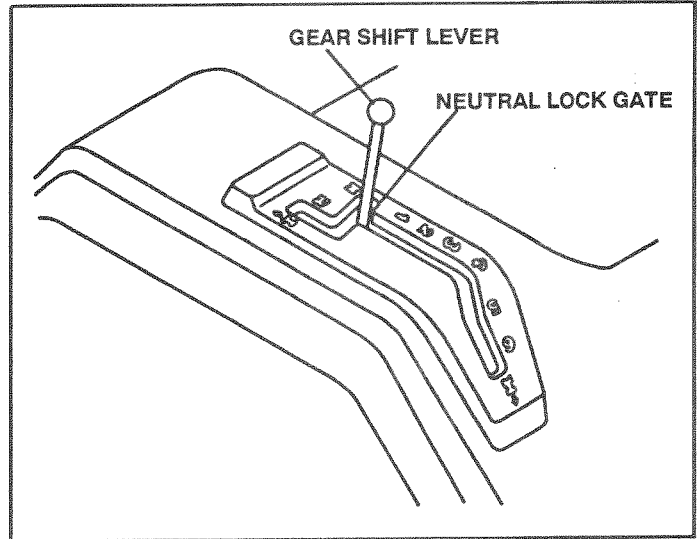

FIG. 33

- Turn center rod until gearshift lever falls into neutral lock gate on fender console.

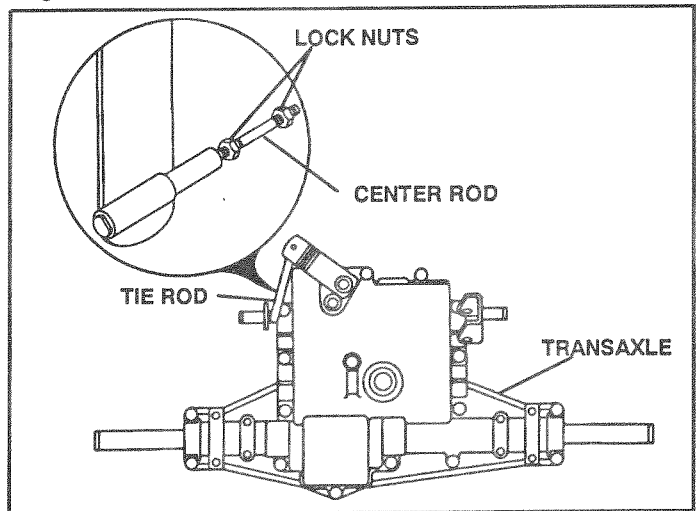

FIG. 34

- Tighten locknuts securely.

TO ADJUST STEERING WHEEL ALIGNMENT

If steering wheel crossbars are not horizontal (left to right) when wheels are positioned straight forward, remove steering wheel and reassemble per instructions in the Assembly section of this manual.

FRONT WHEEL TOE-IN/CAMBER

The front wheel toe-in and camber are not adjustable on your unit. If damage has occurred to affect the front wheel toe-in or camber, contact your nearest authorized service center.

SERVICE AND ADJUSTMENTS

TO REMOVE WHEEL FOR REPAIRS (See FIG. 35)

- Block up axle securely.
- Remove wheel cover, retaining ring and washers to allow wheel removal (rear wheel contains a square key – Do not lose).
- Repair tire and reassemble.
- On rear wheels only: align grooves in rear wheel hub and axle. Insert square key.
- Replace washers and snap retaining ring securely in axle groove.
- Replace wheel cover.

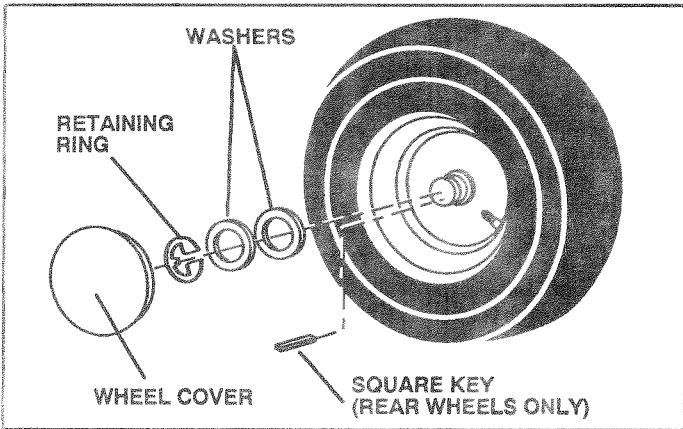

FIG. 35

TO START ENGINE WITH A WEAK BATTERY (See FIGS. 36 and 37)



CAUTION: Lead-acid batteries generate explosive gases. Keep sparks, flame and smoking materials away from batteries. Always wear eye protection when around batteries.

If your battery is too weak to start the engine, it should be recharged. If "jumper cables" are used for emergency starting, follow this procedure:

IMPORTANT: YOUR UNIT IS EQUIPPED WITH A 12 VOLT NEGATIVE GROUNDED SYSTEM. THE OTHER VEHICLE MUST ALSO BE A 12 VOLT NEGATIVE GROUNDED SYSTEM. DO NOT USE YOUR TRACTOR BATTERY TO START OTHER VEHICLES.

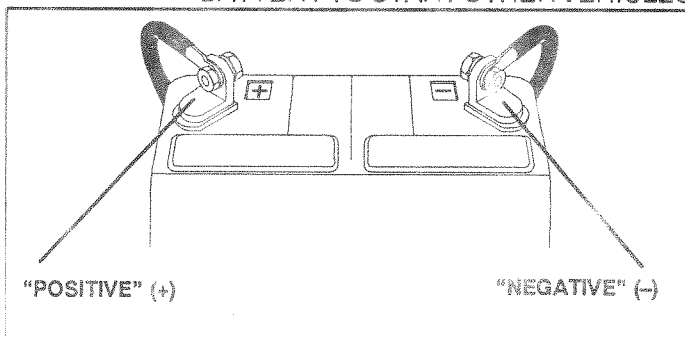

FIG. 36

TO ATTACH JUMPER CABLES

- Connect each end of the RED cable to the POSITIVE (+) terminal of each battery, taking care not to short against chassis.
- Connect one end of the BLACK cable to the NEGATIVE (-) terminal of fully charged battery.
- Connect the other end of the BLACK cable to a panel bolt on the left side of the chassis, away from fuel tank and battery.

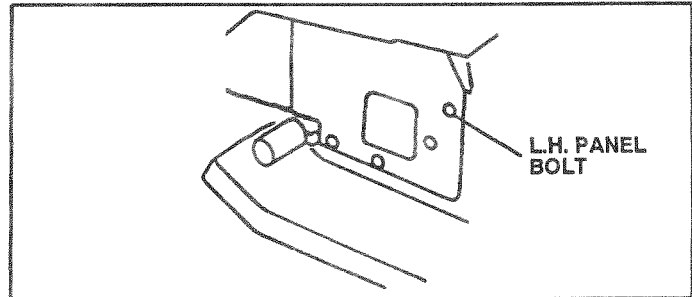

FIG. 37

TO REMOVE CABLES, REVERSE ORDER

- BLACK cable first from left side of chassis and fully charged battery.
- RED cable last from both batteries.

TO REPLACE FUSE

Replace with 30 amp automotive-type plug-in fuse. The fuse holder is located behind the dash.

TO REPLACE HEADLIGHT BULB

- Raise hood.
- Pull bulb holder out of the hole in the backside of the grill.
- Replace bulb in holder and push bulb holder securely back into the hole in the backside of the grill.
- Close hood.

SERVICE AND ADJUSTMENTS

ENGINE

TO ADJUST THROTTLE CONTROL CABLE (See FIG. 38)

The throttle control has been preset at the factory and adjustment should not be necessary. Check adjustment as described below before loosening cable. If adjustment is necessary, proceed as follows:

- With engine not running, move throttle control lever to "FAST" position.
- Check that throttle lever is against stop. If it is not, loosen cable clamp screw and pull cable back until throttle lever is against stop. Tighten cable clamp screw securely.

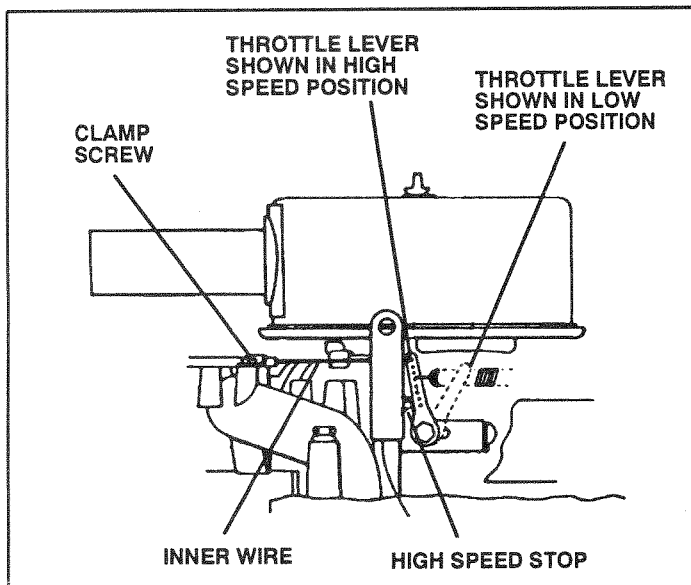

FIG. 38

TO ADJUST CARBURETOR

The carburetor has been preset at the factory and adjustment should not be necessary. However, minor adjustment may be required to compensate for differences in fuel, temperature, altitude or load. If the carburetor does need adjustment, see engine manual packed with your unit.

IMPORTANT: NEVER TAMPER WITH THE ENGINE GOVERNOR, WHICH IS FACTORY SET FOR PROPER ENGINE SPEED. OVERSPEEDING THE ENGINE ABOVE THE FACTORY HIGH SPEED SETTING CAN BE DANGEROUS. IF YOU THINK THE ENGINE-GOVERNED HIGH SPEED NEEDS ADJUSTING, CONTACT YOUR NEAREST AUTHORIZED SERVICE CENTER, WHICH HAS PROPER EQUIPMENT AND EXPERIENCE TO MAKE ANY NECESSARY ADJUSTMENTS.

STORAGE

Immediately prepare your tractor for storage at the end of the season or if the unit will not be used for 30 days or more.



CAUTION: Never store the tractor with gasoline in the tank inside a building where fumes may reach an open flame or spark. Allow the engine to cool before storing in any enclosure.

TRACTOR

Remove mower from tractor for winter storage. When mower is to be stored for a period of time, clean it thoroughly, remove all dirt, grease, leaves, etc. Give blades and underside of housing a good coat of grease or rust preventative. Store in a clean, dry area.

- Clean entire tractor (See "CLEANING" in the Maintenance section of this manual).
- Inspect and replace belts, if necessary (See belt replacement instructions in the Service and Adjustments section of this manual).
- Lubricate as shown in the Maintenance section of this manual.
- Be sure that all nuts, bolts and screws are securely fastened. Inspect moving parts for damage, breakage and wear. Replace if necessary.
- Touch up all rusted or chipped paint surfaces; sand lightly before painting.

BATTERY

- Fully charge the battery for storage.
- After a period of time in storage, battery may require recharging.
- To help prevent corrosion and power leakage during long periods of storage, battery cables should be disconnected and battery cleaned thoroughly (see "TO CLEAN BATTERY AND TERMINALS" in the Maintenance section of this manual).
- After cleaning, leave cables disconnected and place cables where they cannot come in contact with battery terminals.
- Be sure battery drain tube is securely attached to drain in battery tray.

ENGINE

FUEL SYSTEM

IMPORTANT: IT IS IMPORTANT TO PREVENT GUM DEPOSITS FROM FORMING IN ESSENTIAL FUEL SYSTEM PARTS SUCH AS CARBURETOR, FUEL FILTER, FUEL HOSE, OR TANK DURING STORAGE. ALSO, EXPERIENCE INDICATES THAT ALCOHOL BLENDED FUELS (CALLED GASOHOL OR USING ETHANOL OR METHANOL) CAN ATTRACT MOISTURE WHICH LEADS TO SEPARATION AND FORMATION OF ACIDS DURING STORAGE. ACIDIC GAS CAN DAMAGE THE FUEL SYSTEM OF AN ENGINE WHILE IN STORAGE.

- Drain the fuel tank.
- Start the engine and let it run until the fuel lines and carburetor are empty.
- Never use engine or carburetor cleaner products in the fuel tank or permanent damage may occur.
- Use fresh fuel next season.

NOTE: Fuel stabilizer is an acceptable alternative in minimizing the formation of fuel gum deposits during storage. Add stabilizer to gasoline in fuel tank or storage container. Always follow the mix ratio found on stabilizer container. Run engine at least 10 minutes after adding stabilizer to allow the stabilizer to reach the carburetor. Do not drain the gas tank and carburetor if using fuel stabilizer.

ENGINE OIL

Drain oil (with engine warm) and replace with clean engine oil. (See "ENGINE" in the Maintenance section of this manual).

CYLINDERS

- Remove spark plug(s).
- Pour one ounce of oil through spark plug hole(s) into cylinder.
- Turn ignition key to "START" position for a few seconds to distribute oil.
- Replace with new spark plug(s).

OTHER

- Do not store gasoline from one season to another.
- Replace your gasoline can if your can starts to rust. Rust and/or dirt in your gasoline will cause problems.
- If possible, store your unit indoors and cover it to give protection from dust and dirt.
- Cover your unit with a suitable protective cover that does not retain moisture. Do not use plastic. Plastic cannot breathe which allows condensation to form and will cause your unit to rust.

IMPORTANT: NEVER COVER TRACTOR WHILE ENGINE AND EXHAUST AREAS ARE STILL WARM.

TROUBLESHOOTING POINTS

PROBLEM	CAUSE	CORRECTION
Will not start	<ol style="list-style-type: none"> 1. Out of fuel. 2. Engine not "CHOKED" properly. 3. Engine flooded. 4. Bad spark plug. 5. Dirty air filter. 6. Dirty fuel filter. 7. Water in fuel. 8. Loose or damaged wiring. 9. Carburetor out of adjustment. 10. Engine valves out of adjustment. 	<ol style="list-style-type: none"> 1. Fill fuel tank. 2. See TO START ENGINE in Operation section. 3. Wait several minutes before attempting to start. 4. Replace spark plug. 5. Clean/replace air filter. 6. Replace fuel filter. 7. Drain fuel tank and carburetor, refill tank with fresh gasoline and replace fuel filter. 8. Check all wiring. 9. Contact authorized service facility. 10. Contact authorized service facility.
Hard to start	<ol style="list-style-type: none"> 1. Dirty air filter. 2. Bad spark plug. 3. Weak or dead battery. 4. Dirty fuel filter. 5. Stale or dirty fuel. 6. Loose or damaged wiring. 7. Carburetor out of adjustment. 8. Engine valves out of adjustment. 	<ol style="list-style-type: none"> 1. Clean/replace air filter. 2. Replace spark plug. 3. Recharge or replace battery. 4. Replace fuel filter. 5. Drain fuel tank and refill with fresh gasoline. 6. Check all wiring. 7. Contact authorized service facility. 8. Contact authorized service facility.
Engine will not turn over	<ol style="list-style-type: none"> 1. Clutch/brake pedal not depressed. 2. Attachment clutch is engaged. 3. Spark plug wire is disconnected. 4. Weak or dead battery. 5. Blown fuse. 6. Corroded battery terminals. 7. Loose or damaged wiring. 8. Faulty ignition switch. 9. Faulty solenoid or starter. 10. Faulty operator presence switch(es). 	<ol style="list-style-type: none"> 1. Depress clutch/brake pedal. 2. Disengage attachment clutch. 3. Connect wire to spark plug. 4. Recharge or replace battery. 5. Replace fuse. 6. Clean battery terminals. 7. Check all wiring. 8. Check/replace ignition switch. 9. Check/replace solenoid or starter. 10. Contact authorized service facility.
Engine clicks but will not start	<ol style="list-style-type: none"> 1. Weak or dead battery. 2. Corroded battery terminals. 3. Loose or damaged wiring. 4. Faulty solenoid or starter. 	<ol style="list-style-type: none"> 1. Recharge or replace battery. 2. Clean battery terminals. 3. Check all wiring. 4. Check/replace solenoid or starter.
Loss of power	<ol style="list-style-type: none"> 1. Cutting too much grass/too fast. 2. Throttle in "CHOKE" position. 3. Buildup of grass, leaves and trash under mower. 4. Dirty air filter. 5. Low oil level/dirty oil. 6. Faulty spark plug. 7. Dirty fuel filter. 8. Stale or dirty fuel. 9. Water in fuel. 10. Spark plug wire loose. 11. Dirty engine air screen/fins. 12. Dirty/clogged muffler. 13. Loose or damaged wiring. 14. Carburetor out of adjustment. 15. Engine valves out of adjustment. 	<ol style="list-style-type: none"> 1. Set in "Higher Cut" position/reduce speed. 2. Adjust throttle control. 3. Clean underside of mower housing. 4. Clean/replace air filter. 5. Check oil level/change oil. 6. Clean and regap or change spark plug. 7. Replace fuel filter. 8. Drain fuel tank and refill with fresh gasoline. 9. Drain fuel tank and carburetor, refill tank with fresh gasoline and replace fuel filter. 10. Connect and tighten spark plug wire. 11. Clean engine air screen/fins. 12. Clean/replace muffler. 13. Check all wiring. 14. Contact authorized service facility. 15. Contact authorized service facility.
Excessive vibration	<ol style="list-style-type: none"> 1. Worn, bent or loose blade. 2. Bent blade mandrel. 3. Loose/damaged part(s). 	<ol style="list-style-type: none"> 1. Replace blade. Tighten blade bolt. 2. Replace blade mandrel. 3. Tighten loose part(s). Replace damaged parts.

TROUBLESHOOTING POINTS

PROBLEM	CAUSE	CORRECTION
Engine continues to run when operator leaves seat with attachment clutch engaged	<ol style="list-style-type: none"> 1. Faulty operator–safety presence control system. 	<ol style="list-style-type: none"> 1. Check wiring, switches and connections. If not corrected, contact authorized service facility.
Poor cut – uneven	<ol style="list-style-type: none"> 1. Worn, bent or loose blade. 2. Mower deck not level. 3. Buildup of grass, leaves, and trash under mower. 4. Bent blade mandrel. 	<ol style="list-style-type: none"> 1. Replace blade. Tighten blade bolt. 2. Level mower deck. 3. Clean underside of mower housing. 4. Replace blade mandrel.
Mower blades will not rotate	<ol style="list-style-type: none"> 1. Obstruction in clutch mechanism. 2. Mower drive belt out of adjustment. 3. Worn/damaged mower drive belt. 4. Frozen idler pulley. 5. Frozen blade mandrel. 	<ol style="list-style-type: none"> 1. Remove obstruction. 2. Adjust mower drive belt. 3. Replace mower drive belt. 4. Replace idler pulley. 5. Replace blade mandrel.
Poor grass discharge	<ol style="list-style-type: none"> 1. Engine speed too slow. 2. Travel speed too fast. 3. Wet grass. 4. Mower deck not level. 5. Low/uneven tire air pressure. 6. Worn, bent or loose blade. 7. Buildup of grass, leaves and trash under mower. 8. Mower drive belt worn or out of adjustment. 9. Blades improperly installed. 10. Improper blades used. 	<ol style="list-style-type: none"> 1. Place throttle control in “FAST” position. 2. Shift to slower speed. 3. Allow grass to dry before mowing. 4. Level mower deck. 5. Check tires for proper air pressure. 6. Replace/sharpen blade. Tighten blade bolt. 7. Clean underside of mower housing. 8. Replace/adjust mower drive belt. 9. Reinstall blades sharp edge down. 10. Replace with blades listed in this manual.
Headlight(s) not working (if so equipped)	<ol style="list-style-type: none"> 1. Switch is “OFF”. 2. Bulb(s) burned out. 3. Faulty light switch. 4. Loose or damaged wiring. 5. Blown fuse. 	<ol style="list-style-type: none"> 1. Turn switch “ON”. 2. Replace bulb(s). 3. Check/replace light switch. 4. Check wiring and connections. 5. Replace fuse.
Battery will not charge	<ol style="list-style-type: none"> 1. Bad battery cell(s). 2. Poor cable connections. 3. Faulty regulator (if so equipped). 4. Faulty alternator. 	<ol style="list-style-type: none"> 1. Replace battery. 2. Check/clean all connections. 3. Replace regulator. 4. Replace alternator.

SERVICE NOTES

SERVICE NOTES

18 HP 44" RIDING GARDEN TRACTOR -- MODEL NUMBER XC1182B

SCHEMATIC

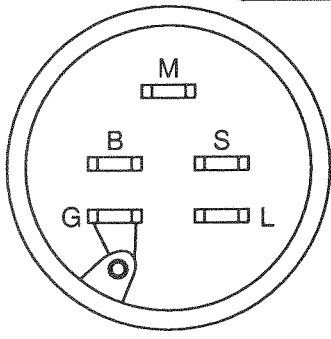
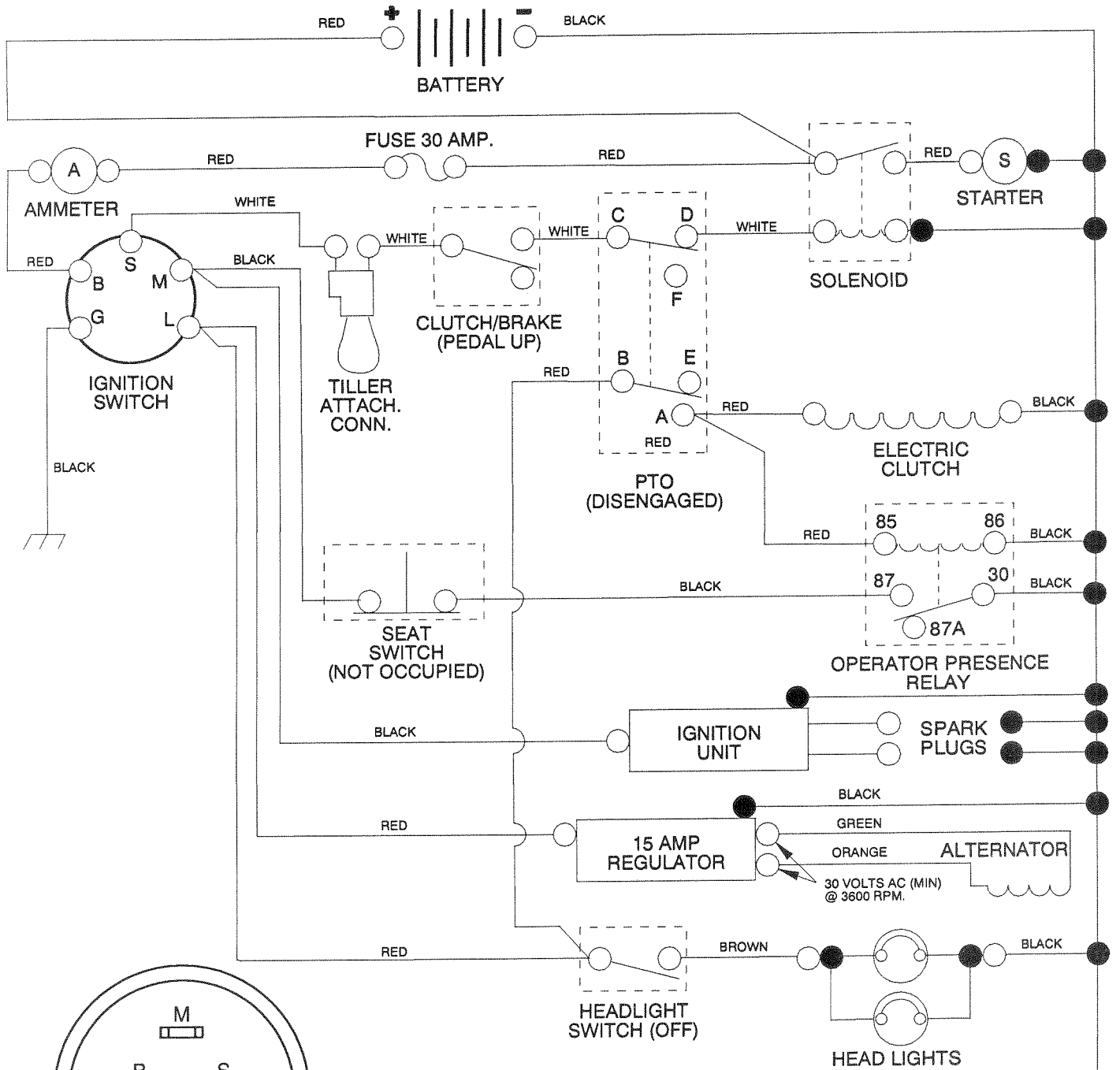

IGNITION SWITCH

POSITION	CIRCUIT
OFF	M + G
ON	B + L
START	B + S

WIRING INSULATED CLIPS

NOTE: IF WIRING INSULATED CLIPS WERE REMOVED FOR SERVICING OF UNIT, THEY SHOULD BE REPLACED TO PROPERLY SECURE YOUR WIRING

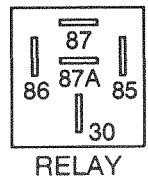

RELAY

- NON-REMOVABLE CONNECTIONS
- REMOVABLE CONNECTIONS

PTO SWITCH

POSITION	CIRCUIT
OFF	B + E, C + D
ON	B + A, C + F

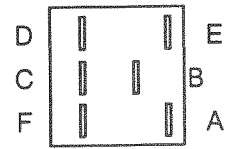

SUGGESTED GUIDE FOR SIGHTING SLOPES FOR SAFE OPERATION

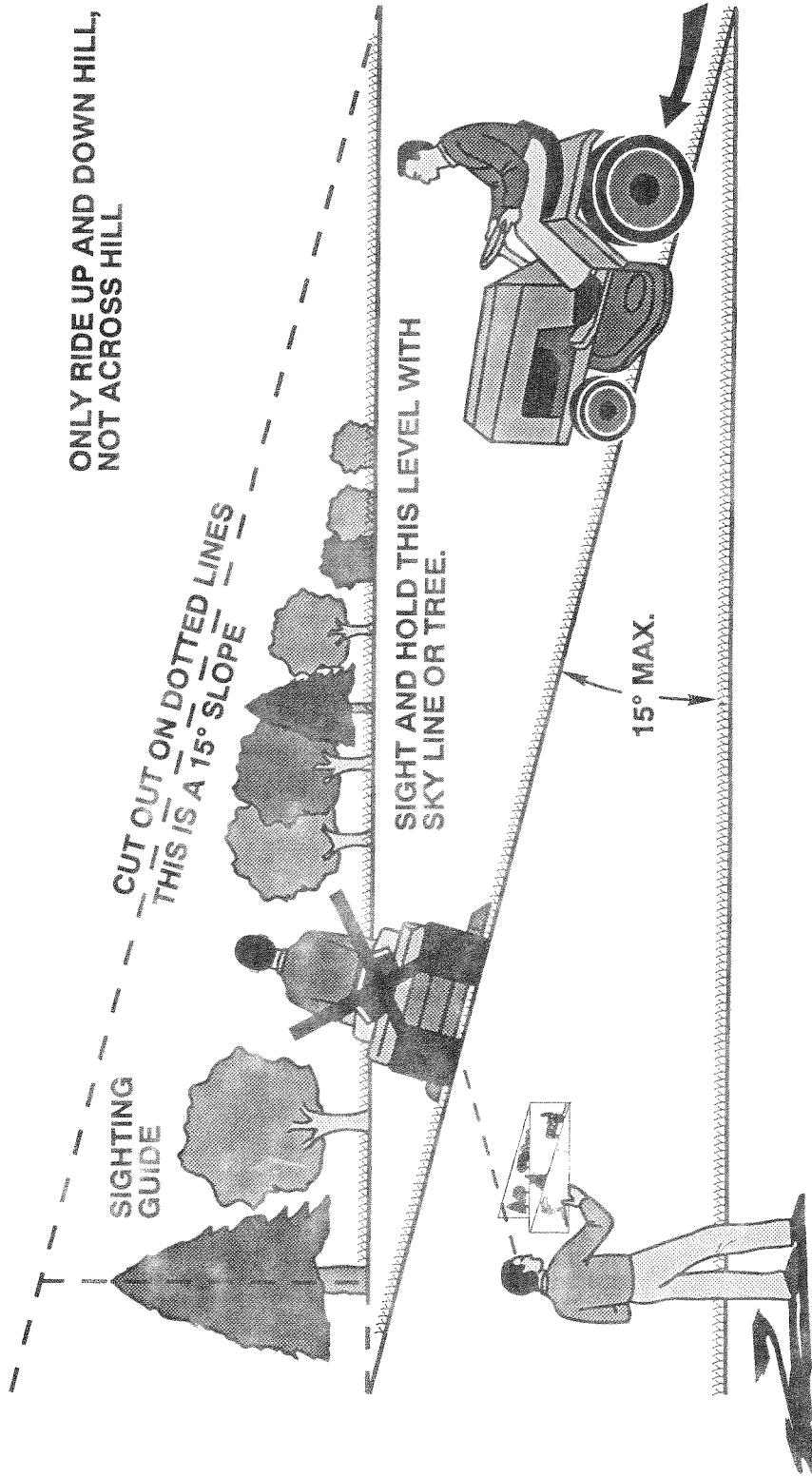

 Operate your Tractor up and down the face of slopes (not greater than 15°), never across the face. Make turns gradually to prevent tipping or loss of control. Exercise extreme caution when changing direction on slopes.

PARTS AND SERVICE

Your POULAN/WEED EATER product has been expertly engineered and carefully manufactured to rigid quality standards. As with all mechanical products, some adjustments or part replacement may be necessary during the life of your unit.

FOR SERVICE OR REPLACEMENT PARTS:

1. Consult your dealer/place of purchase.
2. Consult the yellow pages of your phone directory for the name of the nearest Poulan/Weed Eater Master Service Dealer (under "saws" for Chain Saws or under "lawn mowers" for Trimmers, Brushcutters, and Blowers).
3. For replacement parts, have available the following information:
 - a. Description of the tool.
 - b. Model Number.
 - c. Description of part.

NOTE: Poulan/Weed Eater Division provides parts and service through its authorized distributors and dealers; therefore, all requests for parts and service should be directed to your local dealer(s). The philosophy of Poulan/Weed Eater Division is to continually improve all of its products. If the operating characteristics or the appearance of your product differs from those described in this Operator's Manual, please contact your local Poulan/Weed Eater Dealer for updated information and assistance. Always update your tool when improvements are made available, especially those related to safety. Parts and repair service are not available directly from Poulan/Weed Eater Division White Consolidated Industries, Inc.

POULAN/WEED EATER
DIVISION WHITE CONSOLIDATED INDUSTRIES, INC.
Shreveport, Louisiana 71139-9329

© 1990 Poulan/Weed Eater Division White Consolidated Industries, Inc.

Free Manuals Download Website

<http://myh66.com>

<http://usermanuals.us>

<http://www.somanuals.com>

<http://www.4manuals.cc>

<http://www.manual-lib.com>

<http://www.404manual.com>

<http://www.luxmanual.com>

<http://aubethermostatmanual.com>

Golf course search by state

<http://golfingnear.com>

Email search by domain

<http://emailbydomain.com>

Auto manuals search

<http://auto.somanuals.com>

TV manuals search

<http://tv.somanuals.com>