



Data and Power on a Single Line

Power over LAN™ Midspans

PD-6006, PD-6012 & PD-6024

6/12/24-Port Models

IEEE 802.3af-compliant

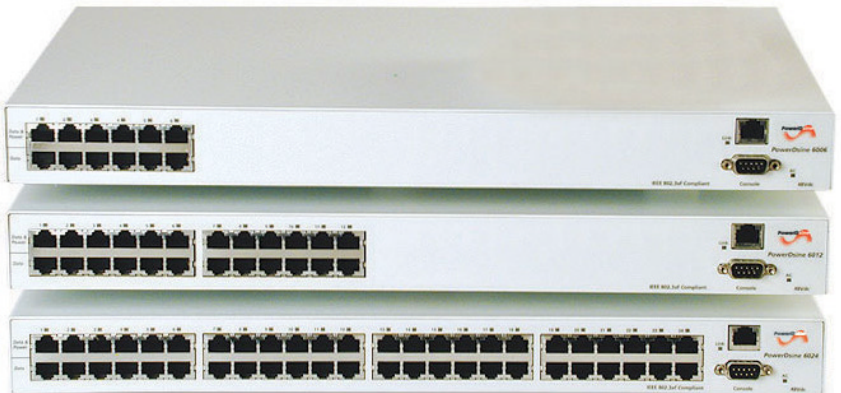

User Guide

Notice

The information contained herein is believed to be accurate and reliable at the time of printing. However, due to ongoing product improvements and revisions, PowerDsine cannot accept responsibility for inadvertent errors, inaccuracies, subsequent changes or omissions of printed material.

PowerDsine Ltd. reserves the right to make changes to products and to their specifications as described in this document, at any time, without prior notice. This material may not be photocopied or reproduced without permission.

Disclaimer

PowerDsine assumes no responsibility or liability arising from the use of Midspans, as described herein, nor does it convey any license under its patent rights or the rights of others. Applications that are described herein for any of these products are for illustrative purposes only. PowerDsine makes no representation or warranty that such applications will be suitable for the specified use without further testing or modification.

The information in this guide refers to the 24-port Power over LAN Midspan only. However this information and illustrations are also applicable for 6 and 12-port AC, DC and AC/DC Power over LAN Midspans.

Note that the Midspan is designed for indoor use only.

© 2003 PowerDsine Ltd.

All rights reserved.

This document is subject to change without notice.

Original publication: 19 March 2003

Date Printed: Jun-18-2003

Acknowledgements

Power over LAN is a trademark of PowerDsine Ltd.

All other products or trademarks are property of their respective owners.

The product(s) described by this manual is (are) a licensed product of PowerDsine.

Contents

1	SAFETY INFORMATION	5
1.1	General Guidelines	5
1.2	Power Cord.....	6
2	ABOUT THE POWER OVER LAN MIDSPAN	7
2.1	Power Management	7
2.2	10/100BASE-TX Ports Definition	8
2.2.1	Data Input Ports	8
2.2.2	Data & Power Output Ports	8
2.3	Indicators	8
2.3.1	Primary Power Indicators.....	8
2.3.2	Port Indications	9
2.4	Connectors	10
3	INSTALLING THE POWER OVER LAN MIDSPAN	11
3.1	Background Information	11
3.2	Rack Mounting Brackets.....	11
3.3	Connecting Ethernet Cables.....	12
3.4	Connecting Power Cables.....	12
3.5	Powering up.....	12
3.6	Troubleshooting	12
3.6.1	Preliminary Steps	12
3.6.2	Troubleshooting Guide.....	13
4	WEB MANAGEMENT.....	15

Model Numbers Definition

PD-60xx/yyyy/M

where: **xx** represents the number of ports (6, 12 or 24)

yyyy establishes the type of input power used, such as:

AC (yy), or **DC (yy)**, or both **AC** and **DC (yyyy)**.

M if present, indicates that the Midspan includes the Web Management feature (refer to Section 4).

The type of input power and the Web Management feature are customer- selected

Verifying Kit Contents

Unpack the kit and verify that the following items are included:

- The Power over LAN Midspan
- Mounting brackets (for 19-inch racks)
- Screws for assembling mounting brackets
- Self-adhesive rubber feet
- User Guide
- Power cord.

Before proceeding, record the unit's serial number below for future reference. The serial number can be found on the information label at the rear of the Power over LAN Midspan.

Serial Number

Electrical Compatibility Approvals

The PD-60xx/ACDC complies with the following standards:

- FCC Part 15, Class B, with FTP cabling; Class A with UTP cabling
- EN 55022 (CISPR 22), Class B with FTP cabling; Class A with UTP cabling
- EN 55024 (CISPR 24)
- Canadian ICES-003, Class B

Safety Standard Approvals

The PD-60xx/ACDC meets the following safety standards:

- UL/cUL per EN60950
- GS mark per EN60950

CE Marking

The CE marking on this product indicates that this product is in compliance with 89/336/EEC (EMC Directive) and 73/23/EEC (Low Voltage Directive).

1 Safety Information

1.1 General Guidelines

You must read the following safety information before carrying out any installation, removal or any maintenance procedure on the Power over LAN Midspan. Warnings contain directions that must be followed for personal and product safety. Follow all directions carefully.

WARNINGS

- Read the Installation Instructions in Section 3 before connecting the Power over LAN Midspan to its power source.
- The Midspan must use a grounded power cord, as defined in paragraph 1.2.
- This product relies on the building installation for short-circuit (overcurrent) protection. Ensure that a fuse or circuit breaker no larger than 15 A for 120 VAC, (U.S.) 10 A for 230 VAC (international) is used.
- Do not work on the system, connect or disconnect cables during periods of lightning activity.
- A voltage mismatch can cause equipment damage and may pose a fire hazard. If the voltage indicated on the label is different from the power outlet voltage, do not connect the Power over LAN Midspan to this outlet.
- For shelf-mounted equipment, be certain that the surface is stable and strong enough to support the equipment. Do not stack more than four the Power over LAN Midspans.
- Ultimate disposal of this product should be handled according to all local laws and regulations.
- The Power over LAN Midspan "Data" and "Data + Power" ports are shielded RJ-45 data sockets. They cannot be used as Plain Old Telephone Service (POTS) telephone sockets. Only RJ-45 data connectors may be connected to these sockets.

1.2 Power Cord

In the event that the power cord is replaced, the replacement must meet local requirements.

- U.S.A. and Canada
- The cord must be UL-approved or CSA certified.
 - The minimum specification for the flexible cord is:
 - No. 18 AWG
 - Type SV or SJ
 - Three-conductor.
 - The cord set must have a rated current capacity of at least 10 A.
 - The attachment plug must be an earth-grounding type with a NEMA 5-15P (15 A, 125 V) or NEMA 6-15P (15 A, 250 V) configuration.
- Denmark
- The supply plug must comply with section 107-2-D1, standard DK2-1a or DK2-5a.
- Switzerland
- The supply plug must comply with SEV/ASE 1011.
- The appliance coupler (connecting to the Midspan and not to the wall plug) must have a configuration for mating with an EN60320/IEC320 appliance inlet.
 - The power socket outlet must be near the Midspan and be easily accessible. *You can only remove power from the unit by disconnecting the power cord from the outlet.*
 - This unit operates under SELV (Safety Extra Low Voltage) conditions according to EN60950/IEC 950. The conditions are only maintained if the equipment to which it is connected also operates under SELV conditions.
 - France and Peru only: This unit cannot be powered from IT supplies. If your supplies are of IT type, this unit must be powered by 230 V (2P+T), via an isolation transformer with a ratio of 1:1 and with the secondary connection point labeled Neutral, connected directly to ground.
 - U.K. only: The Power over LAN Midspan is covered by General Approval, NS/G/12345/J/100003, for indirect connection to a public telecommunications system.

2 About the Power over LAN Midspan

PowerDsine's family of Power over LAN Midspans, series 6000, injects power over data-carrying Ethernet cabling. The PD-6006/6012/6024 Midspans, support 6, 12 and 24 ports respectively in a 10/100BaseTx Ethernet network, over TIA/EIA-568 Category 5/5e/6 cabling. DC operating power, for data terminal units, is fed over unused pairs of the cabling (7/8 and 4/5).

The Power over LAN Midspan normally powers devices that are Power over LAN enabled or are equipped to receive power over Ethernet. These devices are called Powered Devices (PDs). Devices that are not equipped to receive power over Ethernet may require an external power adapter in order to be powered. Contact PowerDsine for such an adapter.

Power over LAN Midspan main features:

- Remote power feeding of Ethernet terminals
- Eliminates the need for AC outlets, local UPS and AC/DC adapters
- Universal range power input (100-240 VAC, 50/60 Hz and/or 46 to 57 VDC)
- Power management
- SNMP management (optional)
- Independent overload and short-circuit protection per channel
- Port status indications
- Standard 19-inch rack mountable.

2.1 Power Management

When establishing a network, the total power required by PDs may exceed the total power available from the Midspan. The built-in Power Management feature will not allow the total power output to exceed the maximum power available (refer to the Technical Specifications). When the total power available is near maximum, attempts to connect an additional PD to a free port will cause the corresponding LED of the port to blink orange, indicating an out-of-power budget. This port will not deliver power. Power distribution is based on "first come, first served" logic.

It is possible that connected and operating PDs will significantly increase or suddenly raise their power requirements. If the power required exceeds the power available, the Power over LAN Midspan will start to turn off ports, starting from the last port down, until the total power is once again under the maximum limit.

2.2 10/100BASE-TX Ports Definition

2.2.1 Data Input Ports

According to the model acquired, the Midspan has 6, 12 or 24 10Base-T/100Base-TX- data input ports, configured in a non-crossover manner (straight-wired). These ports, shown in Figure 2-1 (bottom row of connectors), are designed to carry Ethernet data only (Tx/Rx) over the standard 2-wire pairs (pins 1/2 and 3/6).

2.2.2 Data & Power Output Ports

The Midspan has 6, 12 or 24 Data & Power ports also configured in non-crossover manner (straight-wired). These ports are designed to carry Ethernet data over the standard 2-wire pairs (pins 1/2 and 3/6) and DC power over the spare pairs (pins 4/5 and 7/8).

The Power over LAN Midspan is not a repeater. As such, the maximum distance from the Ethernet switch is not to exceed 100 meters (328 ft). In accordance with the IEEE 802.3 standard, the Power over LAN Midspan is guaranteed to work up to this distance.

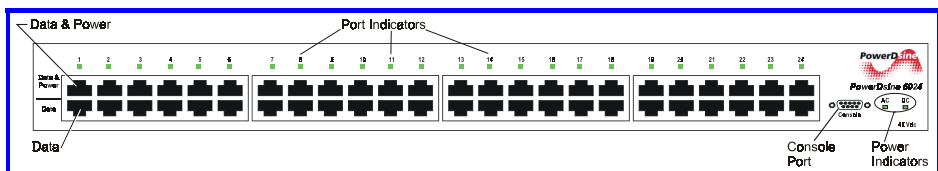

Figure 2-1: Power over LAN Midspan, Front View (PD-6024)

2.3 Indicators

A set of indicators provide the status of the Power over LAN Midspan and its ports. Refer to Table 2-1 and Table 2-2 for status information during operation.

2.3.1 Primary Power Indicators

Depending on the configuration ordered, there may be two LEDs on the front panel, marked by “AC” and “DC”, to provide the Power over LAN Midspan power status. When either one of the indicators is illuminated in green, the Power over LAN Midspan is receiving AC or DC power. The “AC” and “DC” indicators are lit in orange to indicate an internal fault. Refer to Table 2-1 for additional information.

2.3.2 Port Indications

One bi-color indicator (green and orange), per port, provides port status:

- Green indicates that the terminal unit has been identified as "Power over LAN Enabled" and is active and receiving power.
- Orange indicates that the port is not supplying power and is not active.

Refer to Table 2-2 for additional information.

Note Due to the standard detection process performed on each PoL port, power will not be supplied to an Ethernet device, that is not PoL-enabled (indicated in orange or off). In this way, Ethernet devices (not PoL-enabled) will not be affected by this connection.

Table 2-1: Power Status Indications

Indicator	Color	Main Power Status	Remarks
AC	Off	Internal power supply unit is unplugged or faulty.	Internal power supply voltage is too low. All ports are disconnected.
	Green	Indicates AC power input active.	Internal power supply voltage is within tolerance.
	Green blinking	Internal power supply voltage is out of tolerance.	All ports are disconnected.
DC	Off	No DC input power available.	DC input voltage is too low. All ports are disconnected.
	Green	Indicates DC power input active.	DC input voltage is within tolerance.
	Green blinking	DC Input voltage is out of tolerance.	All ports are disconnected.
AC and DC	Orange	Internal problem alarm.	Built in Test (BIT) failed.

Table 2-2: Port Status Indications

Port LED Color	Port Load Conditions	Port Voltage
Off	Non-active load or unplugged port.	Power to the port is disconnected.No DC voltage present on spare pairs.
Green	Active load is plugged in and complies with normal load conditions.	Continuous nominal DC voltage is present on the spare pairs.
Orange	Overload conditions; or short; or forced external voltage feed (constant DC) into the port.	Power to the port is disconnected. No DC voltage is present on the spare pairs.
Green blinking	Transitional mode in which load detection is in process or discharged capacitor in the PD.	Power to the port is disconnected. No DC voltage is present on the spare pairs.
Orange blinking	Total aggregated power exceeds pre-defined power budget.	Power to the port is disconnected. No DC voltage is present on the spare pairs.

2.4 Connectors

The front panel of the Midspan includes a Console port (DB-9 connector). The user may connect a terminal and perform software loading, via this connector, using a standard null modem cable. The console port is set to 19,200-baud, 8 data bits, no parity and 1 stop bit. Pin connections for this connector are:

- Pin 2 is Receive (RXD)
- Pin 3 is Transmit (TXD)
- Pin 5 is Ground
- Pins 1 and 6 are shorted

Each data port is configured as shown in Figure 2-2., as data route-thru ports for all data pins (pins 1, 2, 3 and 6). Be certain to use Category 5 or higher cabling, as shown in the figure.

Figure 2-2: Connecting to the Midspan

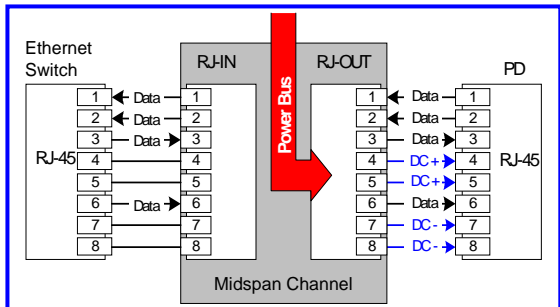

3 Installing the Power over LAN Midspan

3.1 Background Information

As shown in Figure 3-1, the Midspan is connected in series to an Ethernet switch. The data outputs from the switch are connected to the Midspan. The Midspan delivers power over spare twisted pairs (pins 7/8 and pins 4/5) of the Category 5 cabling, without degrading the quality of data communications. Most installations require the Midspan to be rack mounted, as described hereafter.

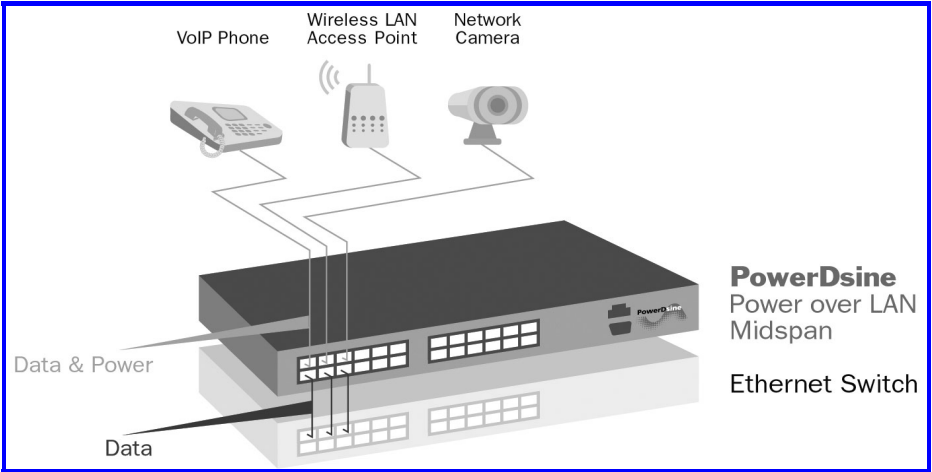

Figure 3-1: Typical Installation

3.2 Rack Mounting Brackets

The Midspan comes with 19-in. mounting brackets and screws. To install the Midspan into a 19-in. rack, first remove the self-adhesive rubber feet from the bottom surface. Install the brackets using two screws per side. Rack-mounting screws are not provided.

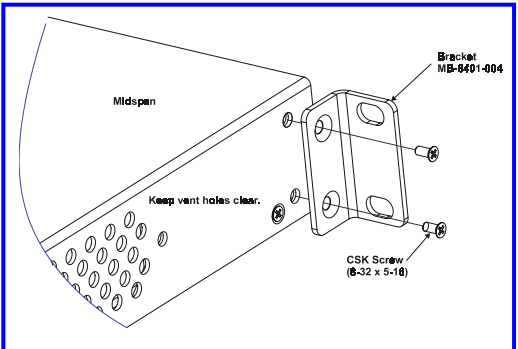

Figure 3-2: Installing Mounting Brackets

3.3 Connecting Ethernet Cables

The ports on the front panel of the Midspan are configured as "route through" ports for all eight conductors of the RJ-45 connectors. Use Category 5 cabling in making connections.

1. Connect cables from the Ethernet Switch to the Data ports (bottom row on Midspan).
2. Connect the cables from the IEEE 802.3af ready terminals (PDs) to the corresponding Data & Power ports (top row on Midspan).

3.4 Connecting Power Cables

When using AC to power the Midspan, plug in the power cord supplied, at the rear AC connector. If DC is to be used (as primary or back-up power), connect the DC primary wiring to a Molex P/N 44441-2002 connector, with 2 Molex terminals P/N 4330-75/0001. Pin 1 is the positive polarity of the DC connector, at the rear of the chassis.

3.5 Powering up

The Power over LAN Midspan has no on/off switch. To apply or remove power to the Midspan, insert or remove the power cable from the receptacle(AC and/or DC) on the rear panel of the unit.

With power applied, the Midspan powers-up and the internal fan operates; then, the device runs through its power-on self-test (POST), which takes less than 10 seconds. During the POST, all ports are disabled and the indicators illuminate in the following sequence:

1. Port indicators and power indicators (AC & DC) illuminate green.
2. Port indicators and the AC indicator illuminate orange.
3. Main (AC or DC) indicator remains lit green; port indicators are out.

Ports are now enabled for normal operation.

3.6 Troubleshooting

3.6.1 Preliminary Steps

If you encounter problems, check that:

- Power is applied to the Midspan
- A crossover-type Ethernet cable has not been used
- The Ethernet cable from the network is connected to the Data port
- The Ethernet cable to the PD is connected to the Data & Power port
- Cable pairs are attached to corresponding ports.

3.6.2 Troubleshooting Guide

This paragraph provides a symptom and resolution sequence in order to assist in the troubleshooting of minor operating problems. If the steps given do not solve your problem, do not hesitate to call your local dealer for further assistance. Refer to Table 3-1.

Table 3-1: Troubleshooting Steps

Symptom	Corrective Steps
<i>Midspan does not power up</i>	<ol style="list-style-type: none"> 1. Verify that a known-good power cord is used. 2. Verify that the voltage at the power inlet is between 100 and 240 Vac. 3. Remove and re-apply power to the device and check the indicators during power up sequence.
<i>AC indicator lit orange</i>	Power-on self-test failed: the Midspan detected an internal fault. In this case, contact your local dealer.
<i>AC and DC indicators lit orange</i>	Power-on self-test failed: the Midspan detected an internal fault. In this case, contact your local dealer.
<i>A port indicator is not lit and the corresponding PD does not operate.</i>	<ol style="list-style-type: none"> 1. The Midspan did not detect a PD and therefore the port is not enabled. 2. Verify that the PD is designed for Power over LAN operation. 3. Verify that you are using a standard Category 5/5e/6, straight-wired cable, with four pairs. 4. If an external power splitter is in use, replace it with a known-good splitter. 5. Verify that the PD is connected to the Data & Power port. 6. Try to reconnect the same PD to a different port on the same or into different Midspan. If it works, there is probably a faulty port or RJ-45 connection.
<i>The end device operates, but there is no data link.</i>	<ol style="list-style-type: none"> 1. Verify that the port indicator on the front panel is continuously lit. 2. If an external power splitter is in use, replace it with a known-good splitter. 3. Verify that for this link, you are using standard UTP/FTP Category 5 straight (non-crossover) cabling, with all four pairs. Check that the link is 100 m or less. 4. Try to re-connect the same end device into a different port on the same unit or into different unit – if it works, there is probably a faulty port or RJ-45 connection.

Table 3-1: Troubleshooting Steps

Symptom	Corrective Steps
Is it safe to keep the Midspan running while a port indicator is orange?	This is a safe condition. The orange indication is due to: <ol style="list-style-type: none"> 1. A device, not compliant to IEEE 802.3af, was detected. 2. Terminals 4/5 and 7/8 are shorted together. 3. Forced external power fed into the port. During these conditions, port power is disconnected.

Technical Specifications

Physical Specifications

Dimensions (h x w x l)	44 x 433 x 302 mm (1.75 x 17 x 11.9 inch)
Weight	4 kg (8.8 lb)

Environmental Specifications

Temperature	
- Operating	0 to 40 °C (32 to 104 °F)
- Storage	-20 to 70 °C (-4 to 158 °F)
Humidity	10 to 90% (non-condensing)

Electrical Specifications

Parameter	PD-6006	PD-6012	PD-6024
AC Input Voltage	90 to 264 VAC at 47-63 Hz		
DC Input Voltage	46 to 57 VDC		
Input Current @ 115 VAC	4 A max.		
Input at 48 VDC	10 A max.		
Total Output Power (1)	92 W max.	200 W max.	200 W max.
Output Power, per Port	15.4 W (not to exceed Total Output Power)		
Nominal Output Voltage	44 to 57 VDC		
Total Output Power (2)	400 W		

- (1) Using AC Power
- (2) Using DC power

4 Remote Power Management

SNMP Remote Management is an optional feature, for monitoring and control of the device. For further details, refer to PowerDsine's PowerView, Power over LAN™ SNMP Web Manager User Guide, catalog number 06-6910-056. PowerView manages Midspans via an Web Manager or via a remote Network Management station, using Java applets. The system provides direct on-line power supervision, configuration, monitoring and diagnostics . It also provides for complete monitoring, control and configuration of PowerDsine products, via their SNMP agents.

PowerDsine PowerView allows for monitoring and controlling at Network and Element levels, as shown in Figure 4-1:

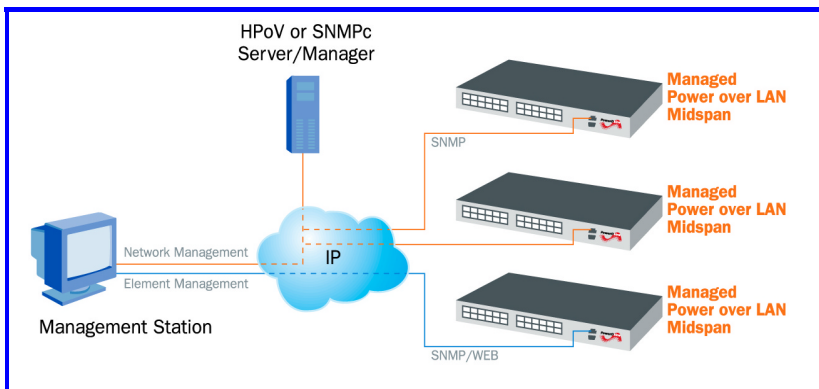

Figure 4-1: Management Deployment

PowerDsine PowerView provides a number of unique features for PoL Midspan management:

- Web-based application for remote management of Power over LAN™ devices
- Web management capabilities for network element management
- Configuration using graphical representations of remote device
- Real time monitoring with visual status indicators and alarms
- Events and performance data recording using trap log
- System status display
- Real time power parameters, in a flowing graph mode
- Optional DHCP enabled-client
- Runs on a PC platform with Windows graphic user interface (GUI).

Covered under US Patent 6,473,608

Visit our web site at: www.powerdsine.com

For technical support, call: +972-9-7755123
In the USA: +631-756-4680 or 1-877-4-802-3AF

Part Number: 06-6800-056

Release 1.0

Free Manuals Download Website

<http://myh66.com>

<http://usermanuals.us>

<http://www.somanuals.com>

<http://www.4manuals.cc>

<http://www.manual-lib.com>

<http://www.404manual.com>

<http://www.luxmanual.com>

<http://aubethermostatmanual.com>

Golf course search by state

<http://golfingnear.com>

Email search by domain

<http://emailbydomain.com>

Auto manuals search

<http://auto.somanuals.com>

TV manuals search

<http://tv.somanuals.com>