



OWNERS MANUAL

MODEL SERIES: P2201
P2701
P3201

Stationary Standby Electric Generator

IMPORTANT SAFETY INSTRUCTIONS – Please make certain that persons who are to install, operate and maintain this equipment thoroughly read and understand these instructions prior to operation. **SAVE THESE INSTRUCTIONS** — This manual contains important instructions that should be followed during installation and maintenance of the generator and battery.

*Product style and configuration may vary.
Specifications are subject to change without notice.*

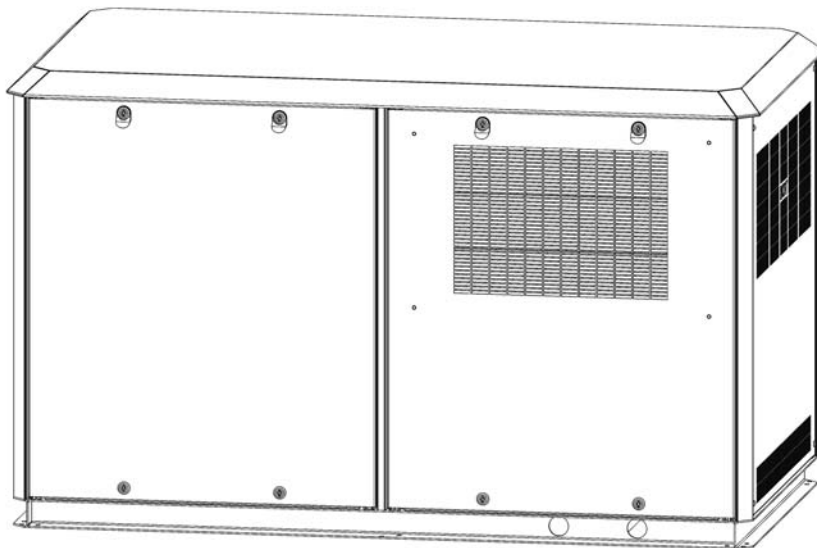

⚠ WARNING: Read and understand all safety precautions in this manual and other manuals included with this product before installing, operating and maintaining this equipment. Failure to comply with instructions in this manual could result in personal injury, property damage, and/or voiding of your warranty. The manufacturer **WILL NOT** be liable for any damage because of failure to follow these instructions.

Record the model and serial numbers of your generator below:

Model Number

Serial Number

Date Purchased

HELPLINE 1-866-769-3703

TABLE OF CONTENTS

Table of Contents	2
General Safety Instructions	3-4
Introduction	5
Unpacking Instructions	5
Installation Planning	5
Specifications	6
Installation Drawing	7
Location and Generator Placement.	8-9
Automatic Transfer Switch	9
Electrical Hookup	10
Main Line Output Power	10
Utility Circuit Supply	11
Generator Start Signal.	11
Wiring Diagram	12
Fuel Specifications & Consumption Requirements	13
Fuel Consumption Table	13
Fuel Hookup	14
Natural Gas Settings.	14
Liquid Propane Vapor Settings	14
Battery Requirements	15
Battery Placement and Connection.	15-16
Lubrication and Cooling.	16
First Time Startup	17
Generator Operation	18
Circuit Breaker.	18
Generator Control Panel Features	18
Generator Control Panel Operation.	19
Starting The Generator	19
Cyclic Crank	19
Run State	19
Shutdown	19
Status Indicators	20
Low Battery.	20
Not In Auto	20
Generator On	20
Generator Control Panel - Faults	20
Overcrank	20
Overspeed	20
High Temperature	20
Low Oil Pressure.	20
Underspeed	20
Maintenance	21-26
Maintenance Chart	21
Engine Oil Level Check.	22
Engine Oil and Oil Filter Change	23
Engine Air Filter Change.	24
Battery Maintenance.	24-25
Spark Plug Check	25
Enclosure And Site	26
Valve Clearance Check And Adjustment	26
Fuel System Inspection.	26
Troubleshooting.	27-28
Notes	29-30
Limited Warranty	31
Service Information	32

GENERAL SAFETY GUIDELINES

The following information relates to protecting YOUR SAFETY and PREVENTING EQUIPMENT PROBLEMS. To help you recognize this information, we use the following symbols. Please read the manual and pay attention to these sections. Also read and follow all safety labels on the engine/generator set. If labels are damaged or unreadable, contact product service for replacements.



This is the safety alert symbol. It is used to alert you to potential personal injury hazards. Obey all safety messages that follow this symbol to avoid possible injury or death.



Ground Location.

⚠ DANGER: – A POTENTIAL HAZARD THAT WILL CAUSE SERIOUS INJURY OR LOSS OF LIFE.

⚠ WARNING: – A POTENTIAL HAZARD THAT COULD CAUSE SERIOUS INJURY OR LOSS OF LIFE.

⚠ CAUTION: – A POTENTIAL HAZARD THAT MAY CAUSE MODERATE INJURY OR DAMAGE TO EQUIPMENT.

NOTE: Improper installation can damage your electrical system and cause property damage, serious personal injury or death. Installation **MUST** be performed by a licensed electrician, plumber and gas technician. Installation **MUST** comply with all applicable building and electrical codes. Some areas may require building permits and/or detailed sight inspections prior to approving the unit for operation.





NOTE: The important safety instructions appearing in this manual are not meant to cover all possible conditions and situations that may occur. It must be understood that common sense, caution, and care are factors which are not built into a generator, but are supplied by the person(s) installing, maintaining, and operating it.

⚠ WARNING:





- ⚠** Do not attempt to install the generator yourself. Extremely high and dangerous electrical voltages are present in utility power source lines and in generator load leads when the unit is running. Therefore, be sure to turn OFF all power voltage supplies at their source before attempting to complete electrical connections. Only qualified installation contractors or electrician's who are familiar with applicable codes, standards, regulations and procedures should install the system. Improper or unauthorized installation, operation, or service of this equipment is extremely hazardous and may result in serious personal injury or death.
- ⚠** It is NOT intended that the information in this manual be used by any unqualified persons for the purpose of installing a standby electric power system. This equipment must be installed, inspected, tested and adjusted only by qualified personnel. These people must be familiar with the equipment and installation requirements.
- ⚠** The installation of this unit must comply with the regulations of the United States National Electric Code (NEC) as well as state and local codes and Occupational Safety and Health Administration (OSHA) established in the United States.
- ⚠** This equipment, when installed as part of a standby electric power system, must be installed in conjunction with an approved transfer switch. The transfer switch serves to prevent both generator and utility power from being connected to the load circuits at the same time. A properly connected transfer switch helps to prevent backfeed of generator power into commercial lines while the standby generator is operating.
- ⚠** This generator supplies extremely high and dangerous power voltages. Any contact with high voltage electrically "hot" components will result in extremely hazardous, and possibly LETHAL, electrical shock. Use care to avoid contact with live terminals, bare connectors, bare wires, etc. Disconnect all power before performing maintenance or service.
- ⚠** Generator exhaust air contains carbon monoxide, a deadly odorless, colorless and tasteless gas. Breathing carbon monoxide causes severe nausea, fainting or death. Install the generator set outdoors only. Do not use exhaust air to heat a room. Do not allow exhaust air to enter a building through windows, doors, air intakes or other means. Avoid breathing exhaust air while installing, operating or servicing generator set. The engine exhaust from this product contains chemicals known to the State of California to cause cancer, birth defects, or other reproductive harm.
- ⚠** Short circuits can cause bodily injury and/or equipment damage. Do not contact electrical connections with tools or jewelry, make sure clothing and shoes are dry and stand on a dry wooden platform while adjustments are made. Remove wristwatch, rings, and jewelry that can cause short circuits.

GENERAL SAFETY GUIDELINES (Continued)

WARNING:

-  The National Electrical Code (NEC) requires the frame and external electrically conductive parts of the generator to be connected to an approved earth ground.
-  Keep a fire extinguisher near the generator at all times. Extinguishers rated "ABC" by the National Fire Protection Association are appropriate for use on the standby electric system. Keep the extinguisher properly charged and be familiar with its use. If you have any question pertaining to fire extinguishers, consult your local fire department.
-  Generator/engine noise can cause hearing loss. Never operate the generator set without a muffler or with a faulty exhaust system. Always wear hearing protection when near or operating the generator.
-  **DO NOT** permit anyone to operate the standby electric system without proper instruction.
-  In case of accidents caused by electric shock, immediately shut down the source of electrical power. If this is not possible, attempt to free the victim from the live conductor. **AVOID DIRECT CONTACT WITH THE VICTIM.** Use a nonconducting implement, such as a rope or board, to free the victim from the live conductor. If the victim is unconscious, apply first aid and get immediate medical help.

CAUTION:

-  Units with broken or missing parts, without protective housing or covers should never be operated. Contact your service center for replacement parts.
-  Inspect the generator regularly, and contact your nearest Authorized Dealer for parts needing repair or replacement.
-  Never use the generator or any of its parts as a step. Stepping on the unit can stress and break parts, and may result in dangerous operating conditions from leaking exhaust gases, fuel leakage, oil leakage, etc.
-  Thoroughly read the **OPERATORS MANUAL** before operating the generator. Safe operation and top performance can be obtained only when equipment is operated and maintained properly.
-  Ensure that enclosure doors are closed and locked at all times other than during service.

INTRODUCTION

The stationary standby electric generator is manufactured for our customers to supply reliable backup power. The generator is a compact unit, designed to supply the power for your critical needs when utility power fails.

The standby generator will run on Liquid Propane Gas or Natural Gas allowing flexibility for getting the power you need. Fuel lines should be installed by a licensed plumber or other qualified professionals or licensed gas technician.

⚠ WARNING

RISK OF ELECTROCUTION AND/OR INJURY



- **The installation of this equipment must be done by licensed electricians, contractors and gas technicians or plumbers. Installation must be completed in conformance with NEC and local electrical and building codes. Some areas may require building permits and/or detailed sight inspections prior to approving the unit for operation.**

•About the Owners Manual

Understanding the operation of the generator is important when using or maintaining your system. If there are any questions about the information supplied in this Owner's Manuals, call our customer service helpline number shown on the manual cover.

•About Operation or Maintenance

All required safety checks that need to be performed are the responsibility of the operators. Listed within the Owners Manual are safety precautions that need to be followed to prevent personal injuries to persons around the unit and to prevent property damage.

UNPACKING INSTRUCTIONS

Immediately inspect the generator carefully for freight loss or damage upon arrival. If loss or damage is noted at the time of delivery, require the person making the delivery to note the loss or damage on the freight bill, or affix his signature under the consignor's memo of the loss or damage. Contact the carrier for claim procedures.

When loss or damage is noted after delivery, segregate the damaged material, and contact the carrier for claim procedures. Be sure to retain the packaging material for carrier inspection.

"Concealed Damage" is understood to mean damage to the contents of a package which is not evident at the time of delivery by the carrier, but which is discovered later. The carrier or carriers are responsible for merchandise lost or damaged in transit. The title to goods rests with the consignee when generators are shipped F.O.B. factory, and only the consignee can legally file a claim.

After inspecting the generator, engine and enclosure for physical damage, finish reading the Operating and Maintenance Instructions. These manuals contain important safety information.

⚠ WARNING

RISK OF INJURY AND BEING CRUSHED



- **HEAVY EQUIPMENT. Unbalanced weight. Improper lifting can cause severe injury or death and equipment damage.**
- **When lifting the generator or using hoisting equipment, be careful not to touch overhead power lines. Proper tools and equipment and qualified personnel should be used in all phases of handling and unpacking.**

INSTALLATION PLANNING

⚠ DANGER

RISK OF INJURY



- **Improper installation can damage your electrical system and cause property damage, serious personal injury or death. Installation MUST be performed by a licensed electrician and plumber or gas technician. Installation MUST comply with all applicable building and electrical codes. Some areas may require building permits and/or detailed sight inspections prior to approving the unit for operation.**

Taking a few moments to pre-plan before beginning installation of the generator can provide significant savings in materials and labor and lower future maintenance. Some items to consider in planning generator installation are safe generator operation, use of an Automatic Transfer Switch, load requirements, generator location, fuel supply, environmental conditions and applicable local, regional or national codes. Some areas may require building permits and/or detailed site inspections prior to approving the unit for use. Check with local authorities before starting installation.

Installation of a standby engine/generator system is complex and should not be considered a Do-It-Yourself project. Safe installation requires the skill and knowledge of licensed electricians and plumbers or gas technicians. Contact an authorized dealer for assistance with installation planning and referral to properly qualified, licensed installing contractors.

GENERATOR SPECIFICATIONS

	P2201 (22 KW)	P2701 (27 KW)	P3201 (32 KW)
Rated Wattage - (Standby) @1.0 PF LPG *	22,000	27,000	32,000
Rated Wattage - (Standby) @1.0 PF NG *	19,800	24,300	28,800
Voltage	120/240 volts	120/240 volts	120/240 volts
Rated Current	184/92 amps LPG	224/112 amps LPG	255/133 amps LPG
Frequency	60 HZ	60 HZ	60 HZ
Power Factor	1.0	1.0	1.0
Max. Ambient Temp Rise	105°C	105°C	105°C
Insulation class	H	H	H
Engine	GM 3.0 L	GM 3.0 L	GM 3.0 L
Engine Type	Water cooled inline (4 cylinders)	Water cooled inline (4 cylinders)	Water cooled inline (4 cylinders)
RPM	1800	1800	1800
Displacement cc (c.i.d)	2966 (181)	2966 (181)	2966 (181)
Bore X Stroke mm (inches)	101.60 x 91.44 (4.00 x 3.60)	101.60 x 91.44 (4.00 x 3.60)	101.60 x 91.44 (4.00 x 3.60)
Compression Ratio	10:5:1	10:5:1	10:5:1
Valve arrangement	Overhead valve	Overhead valve	Overhead valve
Governor	Electronic, Isochronous	Electronic, Isochronous	Electronic, Isochronous
Ignition system	Solid State Distributor	Solid State Distributor	Solid State Distributor
Starter	12vdc, Solenoid Shift	12vdc, Solenoid Shift	12vdc, Solenoid Shift
Alternator	12vdc	12vdc	12vdc
Oil Capacity (w/o filter)	4 qts (3.8L)	4 qts (3.8L)	4 qts (3.8L)
Oil Capacity (with filter)	5 qts (4.7L)	5 qts (4.7L)	5 qts (4.7L)
Oil Filter	PF-25 or equivalent	PF-25 or equivalent	PF-25 or equivalent
Radiator capacity	Shipped with 50/50 mix of water and propylene glycol antifreeze.	Shipped with 50/50 mix of water and propylene glycol antifreeze.	Shipped with 50/50 mix of water and propylene glycol antifreeze.
Spark plug	AC Delco R45TS	AC Delco R45TS	AC Delco R45TS
Battery	BCI Group 34, minimum 750 CCA	BCI Group 34, minimum 750 CCA	BCI Group 34, minimum 750 CCA
Air filter	019-0255	019-0255	019-0255
Minimum Content Requirements for Natural Gas (NG) **	1000 BTU's per cubic foot	1000 BTU's per cubic foot	1000 BTU's per cubic foot
Minimum Content Requirements for Liquid Propane Vapor (LPG) **	2520 BTU's per cubic foot	2520 BTU's per cubic foot	2520 BTU's per cubic foot
Consumption at Full Load for Natural Gas (NG)	280 cubic feet per hour	304 cubic feet per hour	315 cubic feet per hour
Consumption at Full Load for Liquid Propane Vapor (LPG)	3.44 gallons per hour	3.71 gallons per hour	3.99 gallons per hour
Dimensions (see next page for installation drawing)	66"L x 35"W x 41"H	66"L x 35"W x 41"H	66"L x 35"W x 41"H
Shipping Weight	1300	1300	1300
Normal Operating Range	-20°F (-28.8°C) to 104°F (40°C)		
* Note: Rated wattage is specified at sea level, 60°F ambient temperature, and propane fuel (with 2500 BTU/cuft). Rated wattage decreases approximately 3.5% for each 1000ft above sea level and approximately 1% for each 10°F above 60°F ambient temperature.			
** Fuel supply pressures must be between 4 oz (6" w.c.) and 6 oz (11" w.c.) at inlet to the unit.			

INSTALLATION DRAWINGS

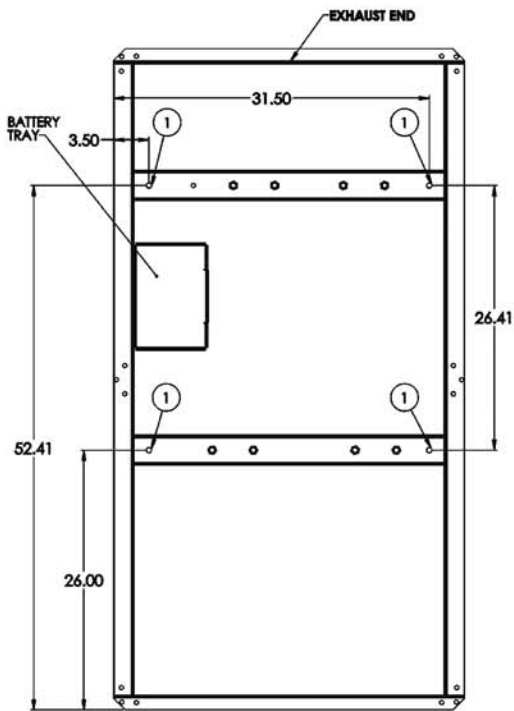
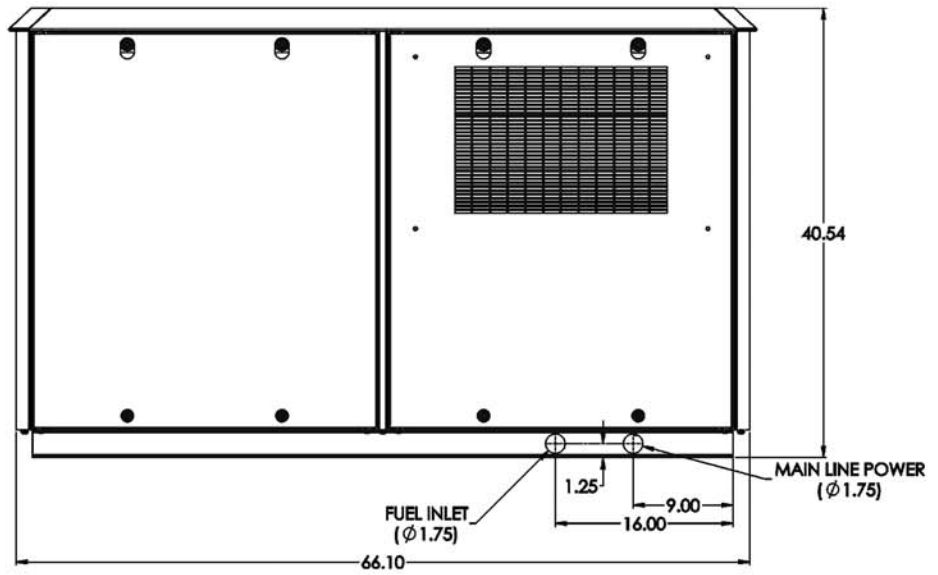

FRAME

NOTE:
1. USE ANCHOR BOLTS .50" DIAMETER

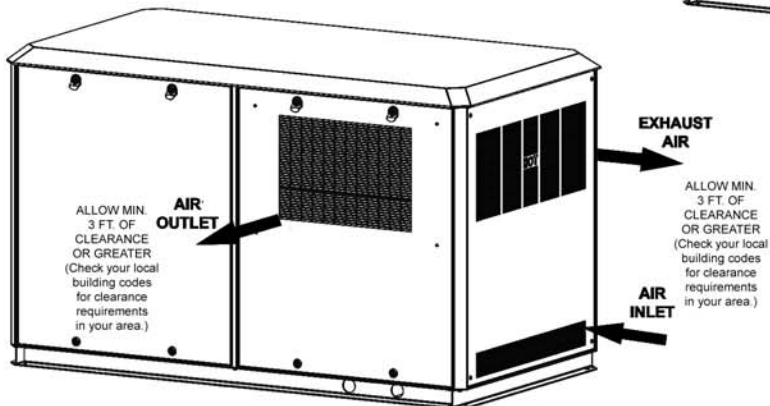
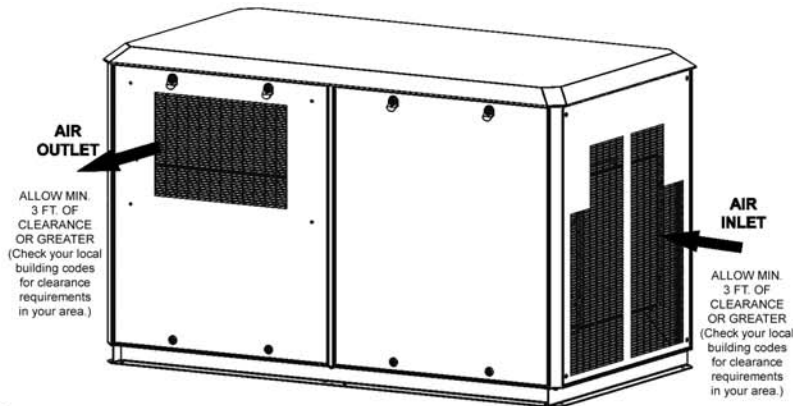

LOCATION AND GENERATOR PLACEMENT

For proper ventilation and maintenance, locate the generator outdoors in an area that will allow a minimum of three feet or more of clearance between the generator and any other structure. **Note: Check your local building codes for clearance requirements for your area.**

When placing the generator, the direction of the exhaust should be pointing away from windows, doors and any ventilation system.

Insure that sufficient air flow is available to remove the exhaust fumes and cool the generator properly.

The generator should be installed with masonry anchor bolts on a level wire reinforced cement pad that is 4-6 inches thick and extends a minimum of 6" around all sides of the unit (see page 7 for anchor bolt locations).

NOTE: It would be extremely difficult, if not impractical, to attempt a detailed coverage of every installation possibility. For that reason, much of the information is general in nature. Plan the installation carefully. Information in this manual is provided as a guide only and is not meant to serve as a detailed installation plan. Illustrations provided in the manual must not be construed as blueprints.

NOTE: The generator has an engine fan that draws the air in from the end panel slots, circulates it within the enclosure and forces the air through the side panels and the exhaust panel slots.

All local applicable codes, standards and regulations must be followed for the installation of the generator. Some areas may require building permits and/or detailed sight inspections prior to approving the unit for use.

NOTE: Utility wiring from the house to power the battery charger and other start assisting components should be tightened on the identified terminal block at a torque of 20 lb-in. The wire size is to be selected according to allowable ampacities given in Table 310-16 of the National Electric Code.

Signal wiring from the transfer switch is to be 18AWG multi-strand wire tightened on the identified terminal block to a torque of 20 lb-in.

Power leads from the generator/circuit breaker being wired to the transfer switch should be tightened in the identified terminal block to 120 lb-in. The wire size is to be selected according to allowable ampacities given in Table 310-16 of the National Electric Code.

Field wiring of this unit must be conducted by a licensed electrician.

⚠ WARNING



- Hazardous voltage can cause severe injury or death. Electrocution is possible whenever electricity is present. Open the main circuit breaker of all power sources before servicing the equipment. Configure the installation to electrically ground the generator set, transfer switch and related equipment and electrical circuits to comply with applicable codes and standards. Never contact electrical leads or appliances when standing in water or on wet ground because these conditions increase the risk of electrocution.
- The exhaust from this product is extremely hot and remains hot after shutdown. High grass, weeds, brush, leaves, or other combustible materials, must remain clear of the exhaust. Such materials may ignite and burn from the heat of the exhaust system.

⚠ DANGER



- The generator engine exhaust fumes contain carbon monoxide, which can be DEADLY. This dangerous gas, if breathed in sufficient concentrations, can cause unconsciousness or even death. The generator must be installed properly, in strict compliance with applicable codes and standards. Following installation, you must do nothing that might render the generator unsafe or in noncompliance with such codes and standards.

⚠ CAUTION

- Covering or restricting the air passages on the generator will cause the unit to overheat and may create a fire hazard. Do not allow snow or leaves to cover enclosure openings.
- Leave a three foot or greater open area around all sides of the unit. *Check your local building codes for clearance requirements for your area.* Do not plant trees or plants close to the unit.
- Unit should be located such that it prevents combustible material from accumulating under the generator set.

LOCATION AND GENERATOR PLACEMENT (continued)

⚠ WARNING



- For fire safety, the generator must be installed and maintained properly. Installation always must comply with applicable codes, standards, laws and regulations. Adhere strictly to local, state and national electrical and building codes. Comply with regulations the Occupational Safety and Health Administration (OSHA) and National Electrical Code (NEC) have established.
- This generator is designed to be installed outside only. Never install this unit inside any room, enclosure, or basement. The generator needs adequate cooling and ventilation for continued proper and safe operation.

AUTOMATIC TRANSFER SWITCH

When connecting the generator to a building electrical distribution system, use of a transfer switch is recommended to isolate the normal utility source from the generator supply. By preventing backfeed of the generator power into the utility lines during a utility power outage, the switch provides a level of safety for electrical line workers. An automatic transfer switch listed to Underwriters Laboratories Standard 1008 performs this function while also supplying a method to automatically start and stop the generator set and transfer power to the building electrical system from an appropriate source.

When planning for a transfer switch/generator installation, it is necessary to know the method of interconnection to the building system. As illustrated, it is recommended to connect the generator to power only circuits that are necessary during a power outage. When following this method, the transfer switch feeds only the necessary circuits. Another option is to connect the transfer switch directly to the entire building electrical distribution system. In this case, all circuits or loads must be controlled to avoid overloading and possibly damaging the generator set.

Switch selection is based on factors such as the size of the building distribution system, available generator power and required generator control system. Due to the complex nature of electrical distribution systems, the sizing, selection and installation of a switch is best handled by a licensed electrician or qualified standby generator dealer. Any switch installation must be performed by a licensed electrician to the instructions of the switch manufacturer and any applicable local, regional or national codes.

⚠ WARNING



- Hazardous "backfeed" voltage can cause severe injury or death. Install a transfer switch in standby power installations to prevent connection of standby and other sources of power. Electrical backfeed into a utility electrical system can cause serious injury or death to utility personnel working on transmission lines.
- Do not try MANUAL operation of the transfer switch until all power supplied to the switch has been positively turned OFF. Failure to turn OFF power supplied may result in extremely dangerous and possibly lethal electrical shock or arcing.

Example of Recommended Transfer Switch Installation (Main Panel Load)

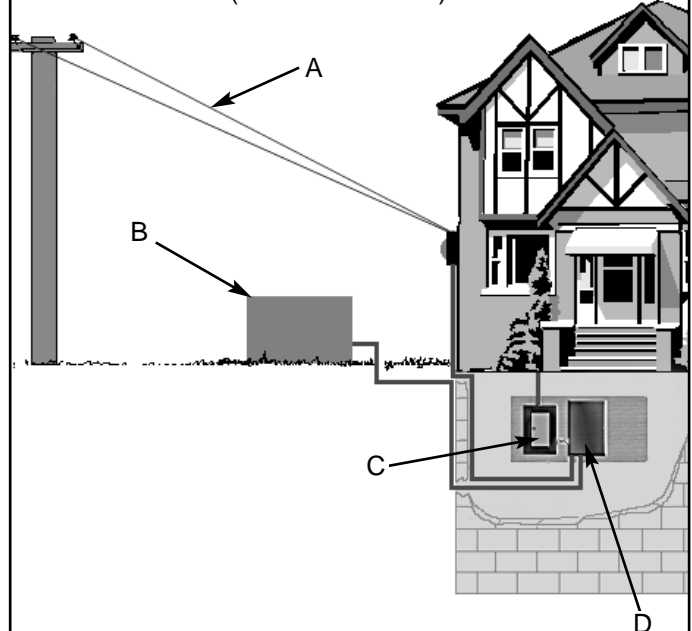

A	Utility Power
B	Standby Generator
C	Main Circuit Panel
D	Automatic Transfer Switch

ELECTRICAL HOOKUP

Once the generator is anchored in its final position, it is ready for electrical connections. The generator is supplied with two terminal blocks for connection of three distinct electrical circuits; main line output power, utility power input and generator start signal. Main line output power is the electrical output of the generator, utility input powers the battery charger and optional block heater devices and the generator start signal is the interface with an Automatic Transfer Switch that allows the generator to operate automatically upon a utility power outage.

DANGER



- Improper installation can damage your electrical system and cause property damage, serious personal injury or death. Installation **MUST** be performed by a licensed electrician and plumber, or gas technician and installation **MUST** comply with all applicable building and electrical codes. Some areas may require building permits and/or detailed sight inspections prior to approving the unit for operation.

MAIN LINE OUTPUT POWER

The output circuit of the generator is 4-wire, 240V, rated for the amperage as shown on the generator nameplate. Connection to the transfer switch requires two leads, commonly referred to as "hot" leads (L1 & L2), a neutral (N), and ground lead. Positions of these leads are labeled on the main line output terminal block, also shown in Fig. A. **Select proper power output wire sizes according to allowable ampacities given in Table 310-16 of the latest revision of The National Electric Code(NFPA 70).** To connect the wires, strip the insulation back approximately ½" from the end of the wire, insert the stripped end into the terminal block, then torque the terminal block screw to **35 in-lbs (4.0 N-m)**.

WARNING



- In case of accidents caused by electric shock, immediately shut down the source of electrical power. If this is not possible, attempt to free the victim from the live conductor. **AVOID DIRECT CONTACT WITH THE VICTIM.** Use a nonconducting implement, such as a rope or board, to free the victim from the live conductor. If the victim is unconscious, apply first aid and get immediate medical help.

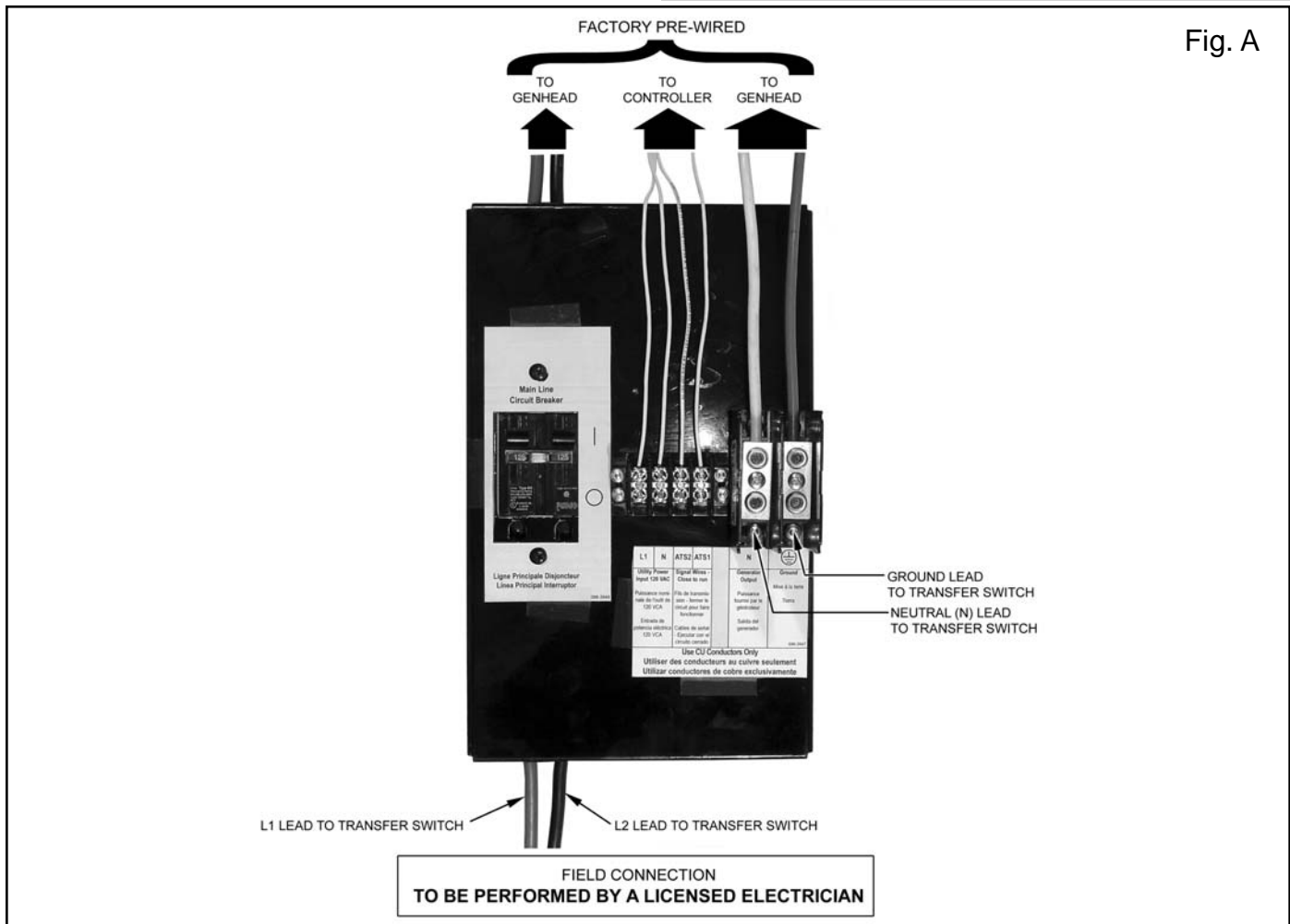

UTILITY CIRCUIT SUPPLY

A receptacle is provided with the generator to power the battery charger for reliable starting. It is also intended to power an optional block heater if that option is desired. Connection of this circuit to a power supply that is only present when normal utility power is supplied is recommended. By connecting the receptacle in this fashion, it is possible to insure that neither the battery charger or block heater are on while the engine is running. Precautions are engineered into the generator to prevent these occurrences but connection of the circuit in this fashion provides an additional fail-safe method of engine and battery protection.

Input to the utility circuit is 3-wire, 120V, 15A. Connections include a "hot" lead (L1), neutral (N) and ground lead. Positions of the incoming wire connections are labeled at the auxiliary connection block, shown in Fig. B. **Select proper utility supply wire size according to allowable ampacities given in Table 310-16 of the latest revision of The National Electric Code(NFPA 70).** To connect the wires, strip the insulation back approximately ¼" from the end of the wire, insert the stripped end under the screw and washer on the terminal block, then torque the terminal block screw to **20 in-lbs (2.3 N-m)**.

GENERATOR START SIGNAL

When the control panel mode switch is placed in the AUTO position, generator starting and stopping is controlled by the opening or closing of a set of voltage free contacts. Two wires from those contacts are connected to the generator through the auxiliary connection block shown in Fig. B. Use of a twisted pair of stranded copper wire no smaller than AWG 18 gage is recommended. To insure proper operation of the auto start feature, use a transfer switch offering "close-to-run control contacts. To connect the wires, strip the insulation back approximately ¼" from the end of the wire, insert the stripped end under the screw and washer on the terminal block, then torque the terminal block screw to **20 in-lbs (2.3 N-m)**.

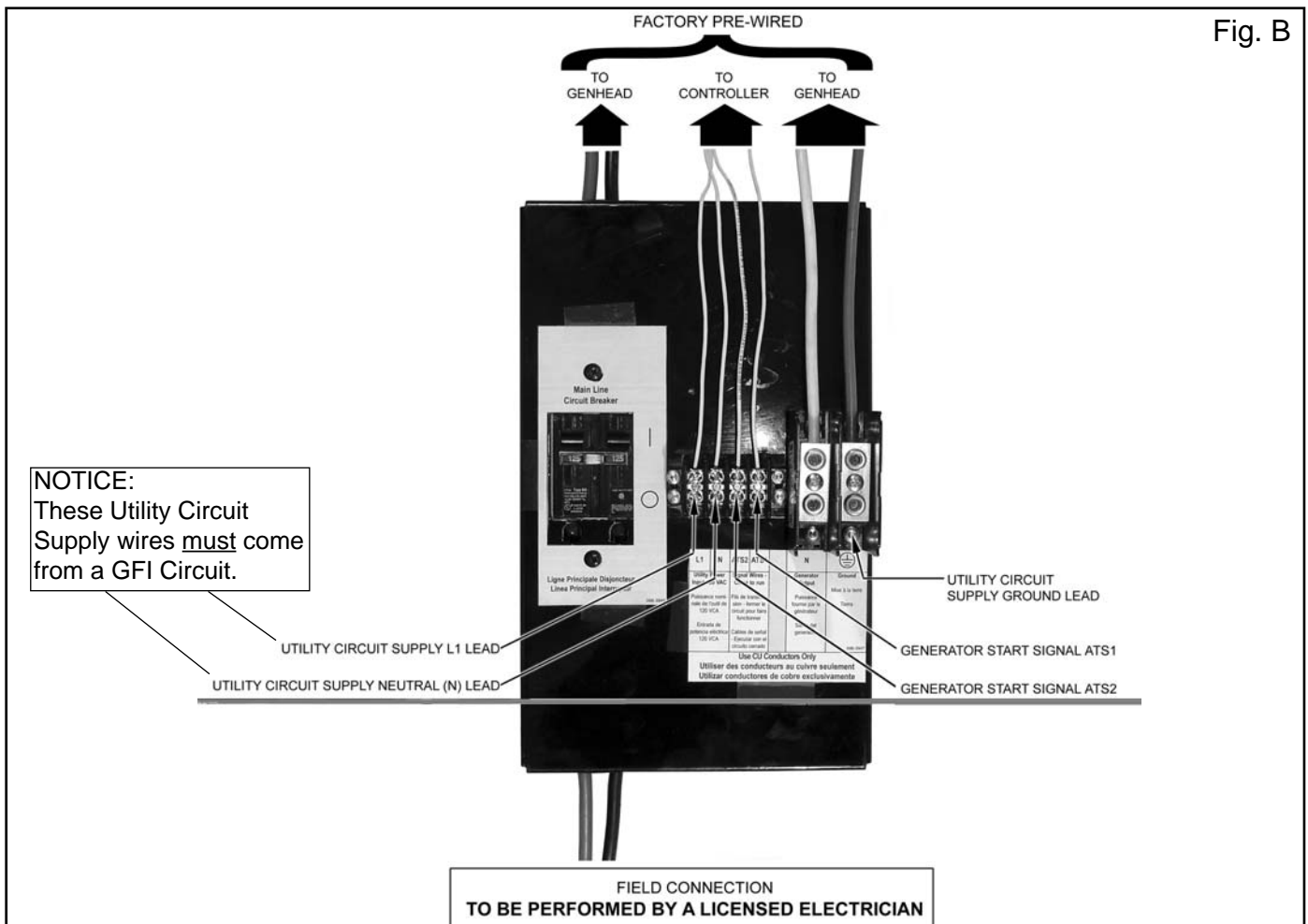
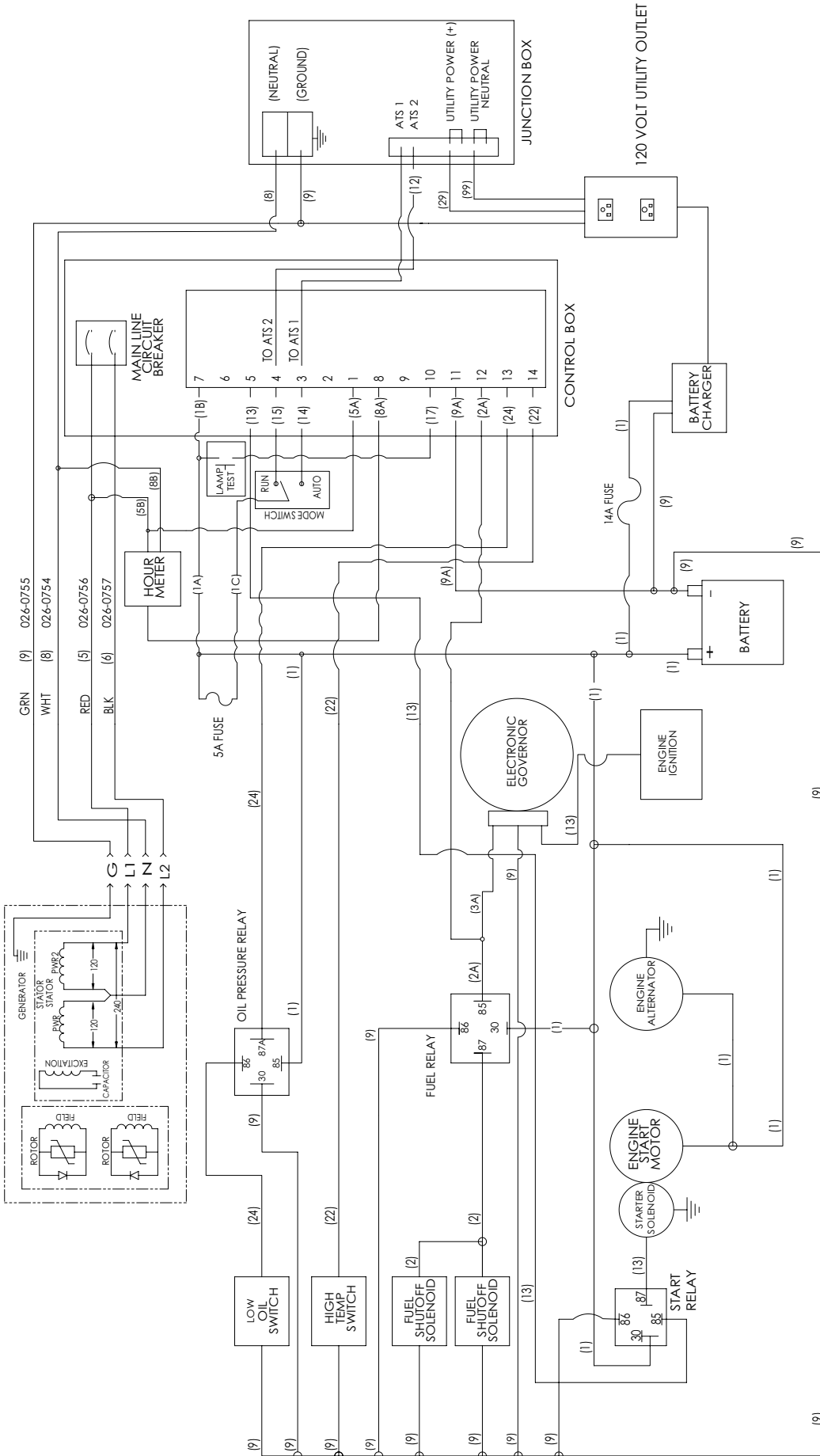

Fig. B

WIRING DIAGRAM (CP200 CONTROLLER)



WIRE NUMBER LEGEND

WIRE #	WIRE NAME/DESCRIPTION	WIRE #	WIRE NAME/DESCRIPTION	WIRE #	WIRE NAME/DESCRIPTION
1B	Battery Positive to CP200	8B	Speed Sense Neutral/Hour Meter	14B	ATS 2 to pin 4 CP200
1D	Battery Positive to Fuse	9A	Ground Relays	15	Start/Stop Input
2A	Fuel Relay Control from CP200	9D	Ground for Relays	17	Lamp Test
2B	Fuel Valve Control from Relay	9E	Ground Governor	22	High Engine Temp Shutdown
3A	Governor Control Voltage	9G	Fuel System Ground	24A	Oil Pressure Shutdown
4	Governor Engine Ignition Signal	12A	ATS 1 to pin 3 CP200	24B	Oil Pressure Switch Shut Down
5A	Speed Sense Hot/Hour Meter to CP200	13A	Crank Output to Relay	25,30,9F	Utility Wires - X3
5B	Speed Sense Hot/Hour Meter to CP200	13B	Start Signal		
8A	Speed Sense Neutral to CP200	14A	Auto Start		

FUEL SPECIFICATIONS AND CONSUMPTION REQUIREMENTS

The engine driving the generator is engineered to provide reliable power on either Liquefied Propane Vapor (LPG) or Natural Gas. For proper operation on these fuels, it is important to deliver gas with adequate energy content, at sufficient pressure and flow rate. This generator is designed to operate on Liquefied Propane Vapor (LPG) with a minimum energy content of 2500 BTU per cubic foot or Natural Gas with a minimum energy content of 1000 BTU per cubic foot. This generator is designed to operate with a **fuel pressure** at the inlet of the unit between **6 and 11 inches of water column (4-6 ounces)**.

Required fuel flow rates for specific models are given in the table below. To insure correct sizing of the piping supplying fuel to the generator set, provide the flow and pressure requirements of this section to a fuel supplier or licensed plumber during the installation planning stage. If the fuel supplier cannot guarantee delivery of fuel with these properties, the generator may not perform as advertised.

Due to differences in the energy content of fuel used, it is necessary to derate the output of the generator when connected to Natural Gas. Additionally, regional and/or seasonal variations in the makeup of the fuel can further affect output of the engine/generator system. When using Natural Gas fuel with minimum properties as defined, engine output can fall approximately 10% below that of the same set using Propane Vapor.

Per the National Gas Code (NFPA 54 - ANSI 2223.1), a manual shutoff valve in the fuel supply line to the generator is recommended.

DANGER



- All fuel system installations **MUST BE** done by a licensed plumber or licensed gas technician and must comply with all applicable codes, standards and regulations.

WARNING



- Natural gas (NG) is highly explosive.
- Natural gas (NG) is lighter than air and will collect in high places.
- Liquid propane vapor (LPG) is highly explosive.
- Liquid propane vapor (LPG) is heavier than air and will collect in lower places.
- Extreme caution should be taken when working on a new installation or while performing general maintenance.
- Do not smoke when near the unit.
- Keep flames, sparks, pilot lights, arc-producing equipment, switches and all other sources of ignition well away. Keep a type ABC fire extinguisher handy.
- Potential for fire or explosion always exist when using natural gas (NG) or liquid propane vapor (LPG) as a fuel source. Install this unit in compliance with all local fuel codes.
- Do Not operate engine if smell of fuel is present or other explosive conditions exist.

FUEL REQUIREMENTS:

For the best operation of the unit, the fuels used should have a minimum content of 1000 BTU's per cubic foot for Natural Gas (NG) and 2520 BTU's per Cubic foot for Liquid Propane vapor (LPG). Contact local fuel supplier for local BTU content. Fuel supply pressures must be between 4oz (6" H₂O per square inch) and 6oz (11" H₂O per square inch) at the inlet to the unit.

FUEL CONSUMPTION TABLE

	22kW	27kW	32kW
Fuel Consumption (@25% load)	0.83 Gal/Hr (LP)	0.94 Gal/Hr (LP)	1.1 Gal/Hr (LP)
	80 Cu-ft/Hr (NG)	85 Cu-ft/Hr (NG)	95 Cu-ft/Hr (NG)
Fuel Consumption (@50% load)	1.65 Gal/Hr (LP)	1.84 Gal/Hr (LP)	2.06 Gal/Hr (LP)
	160 Cu-ft/Hr (NG)	169 Cu-ft/Hr (NG)	180 Cu-ft/Hr (NG)
Fuel Consumption (@75% load)	2.48 Gal/Hr (LP)	2.78 Gal/Hr (LP)	3.03 Gal/Hr (LP)
	220 Cu-ft/Hr (NG)	254 Cu-ft/Hr (NG)	270 Cu-ft/Hr (NG)
Fuel Consumption (@100% load)	3.44 Gal/Hr (LP)	3.71 Gal/Hr (LP)	3.99 Gal/Hr (LP)
	280 Cu-ft/Hr (NG)	304 Cu-ft/Hr (NG)	315 Cu-ft/Hr (NG)

All values reflect consumption at 100% rated output.

FUEL HOOKUP

After electrical connections are complete, the next installation step is to connect a fuel supply to the unit. The fuel inlet fitting supplied with the generator is male 3/4" NPT. To accommodate potential settling of the generator relative to rigid supply pipeline, use of a flexible line, provided by manufacturer, in the supply line is suggested. When making connections, use only materials rated for the fuel supplied and approved for use by local, regional or national codes and/or regulatory agencies.

⚠ DANGER



- All fuel system installations **MUST BE** done by a licensed plumber or licensed gas technician and must comply with all applicable codes, standards and regulations.

⚠ WARNING



- Natural Gas and Propane Vapor are highly explosive gases. Check **ALL** fuel system connections for leaks before starting engine/generator set.
- **DO NOT** use a flame to check for leaks.
- Use approved equipment and methods to check for leaks.

Natural Gas (NG)

Units are tested with natural gas before they leave the factory. If natural gas is to be used, no adjustments are required.

When supplying natural gas as the operating fuel, provide fuel with a minimum of **1000 BTU/ft³ at inlet pressures between 6" and 11" of water column (4 - 6 oz)**. Failure to meet these minimums will cause the generator to run poorly and/or may limit output to values below nameplate value. If fuel with these qualities is not available, contact the customer service center.

Refer to the Fuel Consumption Table on page 13 for fuel flow requirements for the unit installed. Size all feeding piping to deliver sufficient flow above the minimum pressure of 6" water column (4 oz).

Per the National Gas Code (NFPA 54 - ANSI 2223.1), a manual shutoff valve in the fuel supply line to the generator is recommended.

Propane Vapor (LPG)

In cases where liquefied propane vapor is selected as the fuel of choice, the following steps need to be followed for hookup.

Engine Timing for LP

1. Connect timing light to spark plug wire #1, power leads to 12V DC power source (FIG 1).
2. Loosen hold down clamp bolt on distributor (FIG. 2).

NOTE: DO NOT REMOVE!

3. Start generator - ensure all wires from timing light are free from all moving parts.
4. While generator is operating in a no load condition use timing light to obtain engine timing (FIG. 4).
5. Rotate distributor cap (FIG. 3) slowly to obtain timing of 26 degrees BTDC (36 degrees BTDC for natural gas).
6. Retighten hold down clamp bolt (FIG. 2) - **DO NOT MOVE DISTRIBUTOR CAP WHILE RETIGHTENING BOLT.**
7. Reverify timing after tightening hold down clamp.

FIG. 1



FIG. 2



FIG. 3



FIG. 4



BATTERY REQUIREMENTS

To insure reliable starting in most weather conditions, it is important to properly match a battery to the requirements of the generator. The generator uses a 12 Volt, direct current, negative ground control system powered by an automotive style lead acid battery. Successful engine starting is dependent upon the cranking speed of the engine, which in turn is affected by the cranking capacity of the battery. When selecting a battery, choose the model that provides the highest available cold cranking amperes (CCA) within a given size range, as specified by the Battery Council International (BCI). The battery tray and cables supplied with the generator are sized to accept a **BCI Group 34 battery**, with a minimum recommended rating of **750 CCA**.

⚠ WARNING



Lead-acid batteries present a risk of fire because they generate hydrogen gas. The following procedures are to be followed:

- Do not smoke when near batteries.
- Do not cause flame or spark in battery area.
- Discharge static electricity from body before touching batteries by first touching a grounded metal surface.
- Do not dispose of batteries in a fire. The battery is capable of exploding.
- Do not open or mutilate the battery or batteries. Released electrolyte has been known to be harmful to the skin and eyes and to be toxic.

⚠ WARNING



The electrolyte is a dilute sulfuric acid that is harmful to the skin and eyes. It is electrically conductive and corrosive. The following procedures are to be observed.

- Wear full eye protection and protective clothing.
- Where electrolyte contacts the skin, wash it off immediately with water.
- Where electrolyte contacts the eyes, flush thoroughly and immediately with water and seek medical attention.
- Spilled electrolyte is to be washed down with acid neutralizing agent. A common practice is to use a solution of one pound (500 grams) bicarbonate of soda to one gallon (4 liters) of water. The bicarbonate of soda solution is to be added until the evidence of reaction (foaming) has ceased. The resulting liquid is to be flushed with water and the area dried.

⚠ CAUTION



A battery presents a risk of electrical shock and a high short circuit current. The following precautions are to be observed when working on batteries:

- Remove watches, rings or other metal objects.
- Use tools with insulated handles.
- Wear rubber gloves.
- Do not lay tools or metal parts on top of batteries.
- Disconnect charging source prior to connecting or disconnecting battery terminals.
- Determine if the battery is inadvertently grounded. When inadvertently grounded, remove source of ground. Contact with any part of a grounded battery is capable of resulting in electrical shock. The risk of such shock is reduced when such grounds are removed during installation and maintenance.
- Failure to connect and disconnect in the proper sequence can cause equipment damage. Ensure there is a clean tight fit from the cables to the post.

BATTERY PLACEMENT AND CONNECTION

The next step in installation of the generator is placement and connection of the engine cranking battery. Provided battery cables and battery rack are sized to accept a **BCI Group 34** automotive style battery. A battery with a minimum of **750 CCA** (cold cranking amperes) in this size range is recommended to assure reliable engine starting.

⚠ WARNING



- Make sure the control panel Mode switch is in the OFF position before connecting the battery cables. Failure to do so may result in unexpected engine starting and to personal injury.

BATTERY PLACEMENT AND CONNECTION (cont.)

To install the battery, begin by placing the battery (A) into the battery rack as shown in Fig G.

After the battery is in the rack, begin attaching the battery cables to the battery posts, starting with the positive (+), or red, cable (B). Loosen the bolt (C) on the post clamp slightly to allow the clamp to expand, then firmly push the clamp onto the battery post marked positive (+) until the top of the post extends past the top of the clamp. Rotate the clamp around the post as required to insure the clamp cannot contact any metal components, then tighten the clamp bolt (C) until snug. Finally, slide the post boot (D) down the cable and place it entirely over the clamp.

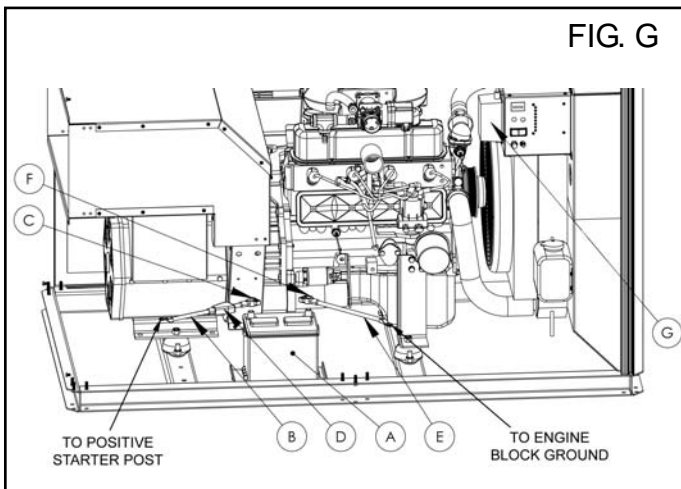

Finish connecting the battery by placing the negative (-), or black, battery cable (E) to the battery post marked negative (-). Push the clamp firmly over the post until the post extends past the top of the clamp, then rotate the clamp to avoid contact with any metal parts. Tighten the battery clamp bolt (F) until snug.

The final step of battery installation is to verify proper connection of all battery charger connections. A battery charging system (G) is included with the engine/generator set to maintain the battery charge during extended periods of generator inactivity, therefore providing consistent starting. A quick check of charger connections will verify that factory connections are correct so the charger can function as intended. Insure that the charger is connected by checking to see that it is plugged into a powered receptacle, and that the positive (+) and negative (-) charger cables are connected to their respective battery cables.

LUBRICATION AND COOLING

Check oil level before start-up. The unit is shipped with the proper type of oil in the crankcase for operation above 40°F. Follow the engine manufacturer's recommendations for oil at temperatures below 40°F. Check oil periodically to ensure that the unit is properly lubricated. Follow the engine manufacturer's recommended service schedule.

Engine oil capacity is 4.0 qt (3.79L) without a filter change and 5.0qt (4.7L) with a filter change.

Before initial start up of the unit, check the coolant level in the radiator. Low coolant levels can cause insufficient engine cooling and possible engine damage. The unit is shipped with a 50\50 mix of water and propylene glycol antifreeze in the radiator. Check coolant levels and concentration periodically, especially in extreme climates. Follow engine manufacturer's recommended service schedule. If radiator is drained and refilled, make sure to disconnect bypass hose to purge air from radiator and engine head water passages.

Failure to properly bleed air from the cooling system may result in an engine failure not covered under warranty.

⚠ WARNING



- Hot coolant under pressure in radiator can cause severe burns. Allow radiator to cool completely before removing cap.
- Eye protection should be used.
- State and federal agencies have determined that contact with used engine oil can cause cancer or reproductive toxicity. Take care to limit skin contact and breathing of vapors as much as possible. Use rubber gloves and wash exposed skin.

⚠ CAUTION

- Too much oil can cause high oil consumption, high operating temperatures and oil foaming. Too little oil can cause severe engine damage. Keep the oil level between the full and add marks on the dipstick.
- Any attempt to crank or start the engine before it has been properly serviced with the recommended oil will result in an engine failure that is not covered under warranty.
- Never run this equipment without the complete air cleaner system installed on the engine. Failure to do so will result in premature engine wear and significantly reduced engine life.

FIRST TIME STARTUP

After completing all installation procedures, read and understand the operating instructions for the generator controller. Know how the control panel operates, what to expect when activating control panel switches and how to shut the generator off in the event of an emergency. Before starting the generator for the first time, check off all items on the following list, then follow the given procedure to verify correct operation of the generator.

- Is unit level?
- Is adequate free air space (3 feet minimum or greater, *check your local building codes for clearance requirements for your area.*) available on all sides of the enclosure?
- Are all cabinet openings free from blockage?
- Is the exhaust directed away from dwellings, dwelling air intakes, or combustible materials?
- Are the fuel supply lines and internal generator fuel connections leak-free?
- Is fuel supply pressure within specifications?
- Is the regulator connection properly configured for the fuel supplied?
- Is an approved transfer switch used to prevent backfeed into utility lines?
- Are electrical connections tight, and properly connected?
- Are electrical conductors sized properly?
- Is the engine filled to the proper level with the correct type of oil?
- Is the engine filled to the proper level with the correct mix of coolant?
- Is a properly sized engine cranking battery correctly installed?
- Is the battery maintenance charger plugged in and operating correctly?
- Are all protective covers installed and tightened?
- Are all tools clear of moving or electrically live parts?
- Is the installation inspected and approved as required by local or regional code?

Once all items on the checklist are marked off, complete the initial startup using the listed steps.

DANGER



- **Contact with high voltages present in generators and utility systems can cause severe electric shock or death. Avoid contact with all live components.**
- **Allow only qualified generator service technicians or licensed electricians to perform initial system start-up.**

1. Place the control panel mode switch on the generator in the OFF position.
2. Move the main line circuit breaker handle on the generator to the OFF position.
3. Check the utility, or preferred, power supply to the

transfer switch following the instructions provided by the switch manufacturer.

4. Ensure utility power to the transfer switch is shut off.
5. Return to the generator and open any manual shutoff valves in the fuel supply system.
6. Move the control panel mode switch to the RUN position. The generator should crank and start.
7. Allow the generator to run for approximately three (3) minutes, then move the main line circuit breaker handle to the ON position.

DANGER



- **Generator is now supplying dangerous voltages. Use extreme caution performing electrical checks.**
8. Check across the terminals of the main line power output block (Red to Black) for proper frequency and voltage. Frequency should read approximately 62.5 Hz and voltage between 240 and 245 volts at no load conditions.
 9. Adjust no load speed as required to meet approximately 62.5 Hz.
 10. Shut the generator down by moving the mode switch back to the OFF position.
 11. Restore utility power to the transfer switch.
 12. Place the control panel mode switch on the generator set in the AUTO position.
 13. Perform a manual exercise cycle following the instructions provided by the switch manufacturer. If wiring is connected properly to the switch, the generator will start and stop under switch control. While the generator is running, check the voltage and frequency across the emergency supply terminals on the transfer switch. Values should match those found in Steps 8 and 9.
 14. Allow the transfer switch to shut the generator off by letting it complete the manual exercise cycle.
 15. With the generator mode switch still in the AUTO position, simulate utility power failure by switching utility power to the transfer switch OFF. Verify correct function of the automatic transfer switch as indicated in the switch manual. Restore utility power to the transfer switch and verify correct automatic transfer switch function. Allow the switch to shut the generator down.
 16. Inspect the site to ensure no packaging or installation materials remain within or against the generator.
 17. Replace all covers on the generator.
 18. Place the generator into service by moving the mode switch to the AUTO position.

CAUTION

- **Failure to set the controller to AUTO before leaving the generator renders the generator unavailable for automatic standby service.**

GENERATOR OPERATION

A standby generator is an engine driven air cooled system to convert the energy contained in either liquid propane vapor or natural gas to electrical power. When coupled with an automatic transfer switch to monitor for failure of utility power, the unattended system can start, stop and transfer between sources to insure a nearly seamless supply of power. The generator is housed in a weather resistant, sound attenuated enclosure for outdoor installation only.

Before installing and starting the generator, become familiar with the controls and operational features of the generator. Know how the control panel operates, what to expect when activating control panel switches and how to shut the generator off in the event of an emergency.

CONTROL PANEL FEATURES

- MODE SWITCH
- STATUS INDICATOR LIGHTS
- HOUR METER
- LAMP TEST SWITCH
- CONTROL PANEL FUSE

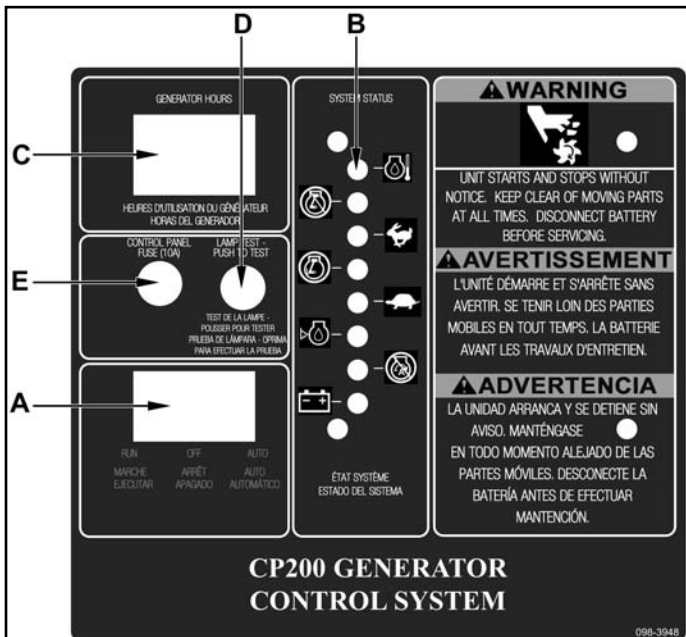

A. Mode Switch

The Mode switch is used to set the operating state of the generator. Placing the switch in the OFF position prevents engine operation or stops the engine if it is already running. Moving the switch to the RUN position immediately starts the generator. Putting the switch in the AUTO position sets the generator for unattended operation under the control of properly matched automatic transfer switch.

WARNING

- With the Mode switch in the auto position, the unit starts and stops without notice.
- Keep clear of all moving parts at all times.

B. Status Indicator Lights

Status indicator lights are provided to communicate the status of the generator to the user. Under normal running conditions, only the green Generator On light is lit. Function of all other lights are described on page 21.

C. Generator Hour Meter

The Generator Hour Meter is provided to track the total numbers of hours of operation. The hour meter runs whenever the engine is running and the alternator is producing electricity. Placing the main line circuit breaker in the OFF position while the engine is running does not stop the meter from counting hours.

D. Lamp Test Switch

A lamp test switch is provided to check for function of all indicator lights. Press the lamp test switch while the engine is at rest, with the control panel mode switch in the OFF position to illuminate all status lights.

E. Generator Control Panel Fuse

The Generator Control Panel Fuse provides protection against damage from electrical faults. Replace the fuse only with an equivalent size and style of fuse to prevent damage to the control system.

CIRCUIT BREAKER

Main Line Circuit Breaker

A Main Line Circuit Breaker is provided to protect the generator from damage caused by electrical faults within the attached electrical distribution system. It is also used to isolate the output of the generator from the connected electrical distribution system by moving the breaker handle to the OFF position. Placing the breaker in this position does not prevent startup of the generator.

WARNING



- Place the circuit breaker in the OFF position when servicing the generator to minimize electrocution hazards.

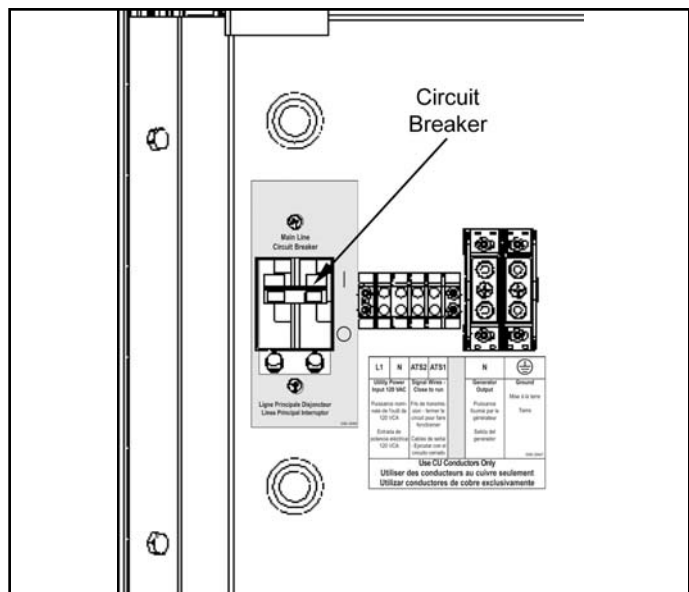

GENERATOR CONTROL PANEL OPERATION

RUN MODES

There are three run mode options: **Run**, **Off** and **Auto**. When the **Run** pushbutton is pressed the unit will immediately start and the “not in auto” light will illuminate. In **Run** mode, the generator will continue to run until the **Off** pushbutton is pressed to stop the unit. At this point the “not in auto” light will illuminate and the unit will not operate.

When the **Auto** pushbutton is pressed the unit will enter automatic run mode, where the generator controller and the transfer switch will control the operation of the unit. In automatic run mode, the unit will automatically start up and shut off when power failure occurs and to exercise the unit.

⚠ WARNING



- **With the Mode switch in the Auto position, the unit starts and stops without notice.**
- **Keep clear of all moving parts at all times.**

When power failure occurs, a signal will be sent to the generator to start a warm up cycle. After the warm up cycle is completed, the transfer switch will allow the load to be transferred to the generator until it senses that regular utility power has been restored. When this occurs, the transfer switch will remove the load from the generator and a signal will be sent to the generator to begin a cool down cycle. After the cool down cycle is completed, the unit will stop running, but remain in the automatic run mode.

The unit will also automatically start itself to ensure it remains in good working order. Every 14 days the unit will automatically start up without warning and run for 20 minutes before shutting down. The unit will remain in automatic run mode after each exercise session.

STARTING THE GENERATOR

Two methods are available to start the generator. The automatic, or AUTO mode is for use with an automatic transfer switch. With the control panel mode switch set to this position, the generator waits for an external signal to start. This signal is supplied by the transfer switch when utility power is of unacceptable quality. Since utility power can fail at any time, be aware **the generator can start unexpectedly whenever in the AUTO position. Keep away from moving parts at all times.** Once utility power is once again acceptable, the signal from the transfer switch is removed, the generator shuts off, then returns to waiting for another signal to start.

The other method for starting the generating is to place the mode switch into the RUN position. This mode

is intended for generator control during maintenance or if an automatic transfer switch is not used. With the control panel switch shifted to this position, the generator will immediately attempt to start after a brief pause. Upon starting, the generator runs until the switch is moved from the RUN position, at which time the generator will shut off.

CYCLIC CRANK

To insure the generator starts without damaging the starter motor, cranking of the engine is performed in a cyclic manner. When the generator is started from either the AUTO or RUN positions, the controller alternates between 10 seconds of engine cranking, followed by 10 seconds of engine rest. If the engine starts during any of the cranking periods, crank attempts are halted and the controller begins monitoring for proper function of the generator. In the event that three 10 second start attempts occur without the engine starting, cranking attempts are halted and the Overcrank light is lit.

RUN STATE

After the engine is started and the generator is producing electrical power, the controller begins operation in a monitoring state. In this state, several generator functions are continuously checked to ensure proper operation of the generator. If functions are determined unacceptable, a fault is declared, the engine is shut down and a status light is lit to communicate the reason for the shutdown.

SHUTDOWN

When operating with the control panel switch in the RUN position, the generator will continue to run until a fault is declared or until the mode switch is moved to the OFF position. Once the switch is shifted to the OFF position, the engine is shut off.

When operating with the control panel switch in the AUTO position, the generator continues to run until a fault light is declared or the run signal is removed. Once the signal is removed, the engine shuts down and the controller returns to waiting for a start signal.

STATUS INDICATORS

Status indicator lights relay conditions of generator function for user or service technician convenience. Illumination of these indicator lights communicate conditions that require generator service but are not severe enough to cause damage if the generator is allowed to operate. Contact a qualified service technician immediately for service if any of the listed lights are lit, even if the generator appears to function normally.

A. LOW BATTERY

The Low Battery light is lit when the cranking battery voltage falls below 11.0 volts. At this level, the battery begins to lose the ability to consistently start the engine. Causes of low battery voltage may include a failing battery, failed battery charger or failed engine alternator.

B. NOT IN AUTO

The Not In Auto light is lit whenever the control panel mode switch is not placed in the AUTO position. This light is provided to call attention to this condition since the generator cannot start automatically during a power outage without the switch in the AUTO position. It is normal for this lamp to light when the generator is running with the mode switch in the RUN position, or if the switch is in the OFF position. To turn the light off, move the mode switch to the AUTO position.

H. GENERATOR ON

The Generator On light illuminates when the generator's engine is running. This is the only light lit when the generator is supplying power as intended.

FAULTS

Fault lights relay conditions that may cause damage to the generator and/or loads connected to the output of the generator. When any of the listed situations occur while the generator is running, the generator is shut down and the fault light associated with the shutdown cause is lit. Once the light is lit, it remains on until it is cleared by moving the control panel mode switch to the OFF position. If a fault light is lit, determine and correct the cause of the problem before restarting the generator. During generator starting, the controller ignores fault conditions until 15 seconds after the generator starts, then uncleared faults will once again cause the generator to shut off. To determine possible fault causes, refer to the troubleshooting section of this manual or contact a qualified service technician for assistance.

C. OVERCRANK

The Overcrank light is lit if all three 10 second cyclic crank attempts are unsuccessful in starting

the engine. Once the light is on, the generator does not attempt to start until the fault is reset. When the Overcrank light is on, verify fuel is available at the inlet to the unit, then check the condition of the cranking battery.

D. LOW OIL

The Low Oil light turns on and the engine is shut off if the engine oil level falls too low. To avoid engine damage, engine oil pressure is monitored to determine the amount of oil in the engine. When pressure falls below a preset level, a Low Oil fault occurs. Check for proper oil level if the generator shuts down due to a Low Oil alarm.

E. HIGH TEMPERATURE

The High Temperature light illuminates if the temperature of the engine becomes too high. Engine oil temperature is monitored while the engine is active and the engine is shut off to avoid damage if the oil temperature becomes too high. When operating the generator in temperatures above the maximum listed on the nameplate, it is necessary to reduce the load connected to the generator to avoid overheating. If high ambient temperatures or excessive loads are eliminated as possible causes of High Temperature shutdown, check to insure cabinet openings are not restricted by debris.

F. OVERSPEED

The Overspeed light is turned on if the generator engine is running too fast. Electrical output of the generator at high speeds may damage loads connected to the generator output and/or engine failure may occur at excessive speeds. If the generator shuts down on an Overspeed error, seek assistance from a qualified generator service technician.

G. UNDERSPEED

The Underspeed light is turned on if the generator engine is running too slow. Electrical output of the generator at low speeds can damage loads connected to the generator output and/or generator failure may occur due to excessive heating in the generator head. If the generator turns off due to an Underspeed error, check to see that the connected loads do not exceed the nameplate rating of the generator.

MAINTENANCE

To ensure reliable generator operation, it is critical to periodically inspect all components. The following chart is provided as a guide for service check intervals. When the generator is operated under excessively hot, or dusty conditions, shorten service intervals according to the severity of the conditions encountered. To perform periodic inspections or maintenance, refer to the

procedures listed in the following sections. A qualified generator service technician should perform inspections or adjustments requiring specialized tools or training. Users unfamiliar with any of the listed procedures should contact an authorized dealer for servicing assistance.

Maintenance Item		Every month or 8 hours	Every 6 months or 100 hours	Every year or 300 hours	Every 2 years or 500 hours
Engine Oil	Check	X			
	Change		X ¹		
Engine Oil Filter	Change		X		
Oil Cooler	Check and clean		X		
Engine Air Filter	Check	X			
	Change			X	
Battery	Check and clean		X		
Battery Charger	Check		X		
Spark Plugs	Check			X	
	Replace				X
Valve Clearance	Check and Adjust			X	
Generator Output Frequency	Check and Adjust			X	
Fuel System	Check		X		
Cooling Air Openings	Check	X			
Engine Coolant	Check and Add if necessary	X			

1. Perform first change at 25 hours.

MAINTENANCE (cont.)

⚠ WARNING



- Before performing any maintenance, make sure the Mode switch is in the OFF position, the circuit breaker is in the OFF position and the positive (red) battery cable is disconnected.
- Generator/engine components are hot to the touch when operating. To prevent burns to the skin allow unit to cool before touching internal generator or engine components.
- Crankcase pressure can blow hot engine oil out the fill opening causing severe burns. Always stop the generator before removing the oil fill cap.
- Keep hands, feet, clothing, etc., away from drive belts, fans, and other moving or hot parts. Never remove any drive belt or fan guard while the unit is operating.
- Hot coolant under pressure in radiator can cause severe burns. Allow radiator to cool completely before removing cap. Eye protection should be used.
- Generator output connections must be made by a qualified electrician in accordance with applicable codes.
- Engine heater (optional) can cause electrical shock. Remove engine heater plug from electrical outlet before working on heater connections.
- Improper service or replacement of parts can lead to severe personal injury or death and to damage to equipment and property. Service personnel must be qualified to perform electrical and mechanical service.
- Use caution when working on live electrical equipment. Remove jewelry, make sure clothing and shoes are dry and stand on a dry wooden platform.
- When performing a high voltage test, hazardous voltage can cause severe injury or death. Follow the instructions of the test equipment manufacturer when performing high-voltage tests on the rotor or stator. An improper test procedure can damage equipment or lead to generator set failure.
- State and federal agencies have determined that contact with used engine oil can cause cancer or reproductive toxicity. Take care to limit skin contact and breathing of vapors as much as possible. Use rubber gloves and wash exposed skin.
- The engine exhaust from this product contains chemicals known to the State of California to cause cancer, birth defects, or other reproductive harm.

ENGINE OIL LEVEL CHECK

Prior to checking the oil level, start the generator by moving the Mode switch on the control panel to the RUN position. Allow the generator to run for one or two minutes, then shut it down by returning the switch to the OFF position. After the engine comes to a stop let the engine set for a couple of minutes before checking the oil level. Begin the level check by removing the dipstick (B), wiping it clean, then reinserting it into the engine. Remove the dipstick a second time, checking that the oil level falls between the upper and lower limit marks on the end of the dipstick, as shown in Fig. A. Adjust engine oil level as required so the level is at the upper limit mark on the dipstick, adding oil to the engine through the oil fill cap (A) as shown in Fig B. Add only oil of the same specification as the oil already in the engine.

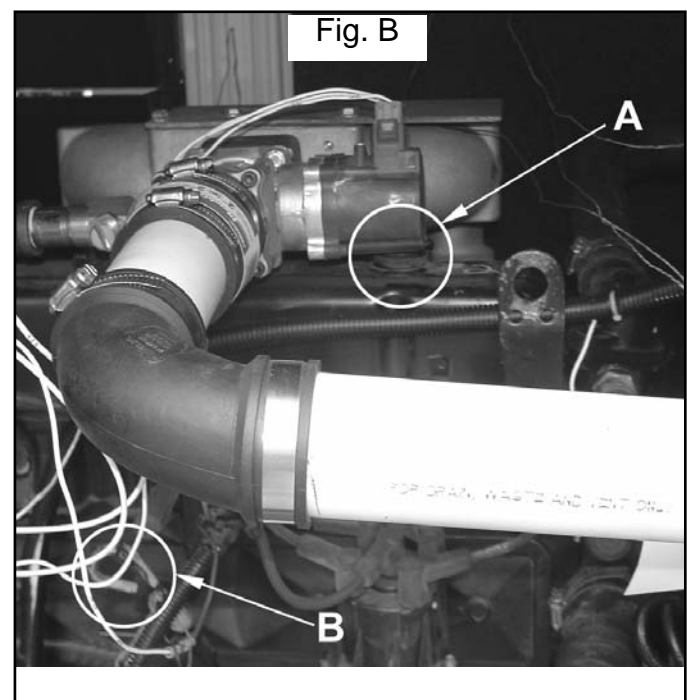
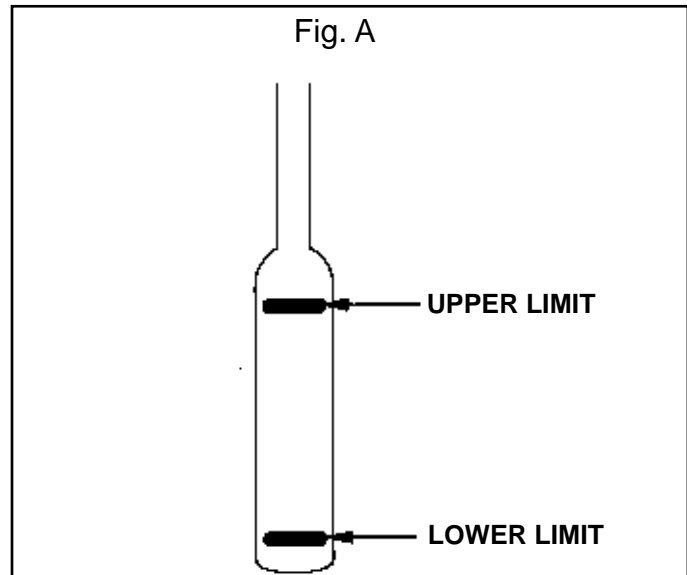

ENGINE AIR FILTER CHANGE

The generator engine is equipped with a dry element air filter to block particles in the combustion air from getting into the engine and causing excessive engine wear. Over time this dirt builds-up on the filter, restricting the amount of combustion air available to the engine, in turn leading to a loss of generator power output. To avoid these problems, periodic replacement of the engine air filter is recommended at the intervals outline in the service schedule table on page 21. To change the air filter, follow the listed steps.

⚠ CAUTION

- **Never run this equipment without the complete air filter installed on the engine. Failure to do so will result in premature engine wear and significantly reduced engine life.**

1. Using a T30 star drive wrench (not included), remove the 4 screws (A) from the radiator end panel (B) of the generator (see Fig. D).
2. Lift and remove the end panel (B).
3. Remove the air filter (C) by loosening the screw on the clamp (D) with a screwdriver.
4. Replace with a new air filter (see specifications for size).
5. Tighten the clamp screw (D).
6. Replace the end panel and tighten the screws.

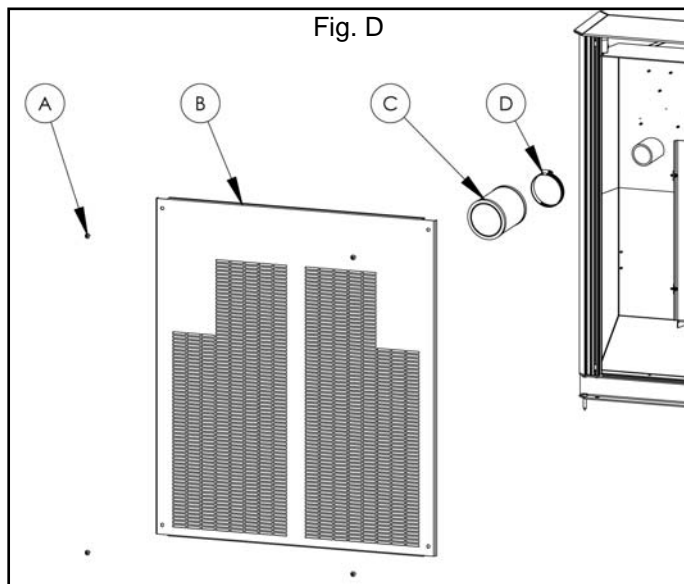

BATTERY MAINTENANCE

⚠ WARNING



- **Read and understand all warnings and cautions on page 15 of this manual before proceeding with any battery maintenance.**

Correctly maintaining the battery at regular intervals is vital to ensure consistent engine starting. Poorly maintained batteries loose charge over time and may not provide enough power to crank the engine fast enough for reliable starts. The steps below are suggested to care for the battery and charger.

1. Access the battery (E) by removing the front generator panels (F). Insert the key (G) into the top locks and turn 1/4 turn counterclockwise to unlock. Lift the panel up and out of the base and set it aside (see Fig. E). *Note: there is no need to turn the locks located on the bottom of the panel.*
2. Keep the battery cable clamps (H) at the battery posts tight and free of corrosion. Replace the battery cables if cracks are found in the clamps.
3. Check and adjust the level of battery electrolyte according to the battery manufacturer's instructions if not using a "maintenance-free" battery. If electrolyte is low, add only distilled water to the battery. Do not add tap water to the battery.
4. Insure the battery charger (I) is powered and functioning properly. A correctly operating battery charger displays lights on the face of the charger to relay the state of the charger. Refer to Table A on page 25 to assess the mode the charger is operating in.
5. Reassemble the front panels (F) to the generator by setting the bottom end of the panel into the base and push into place. Insert the key (G) into the top locks and turn 1/4 turn clockwise to lock.

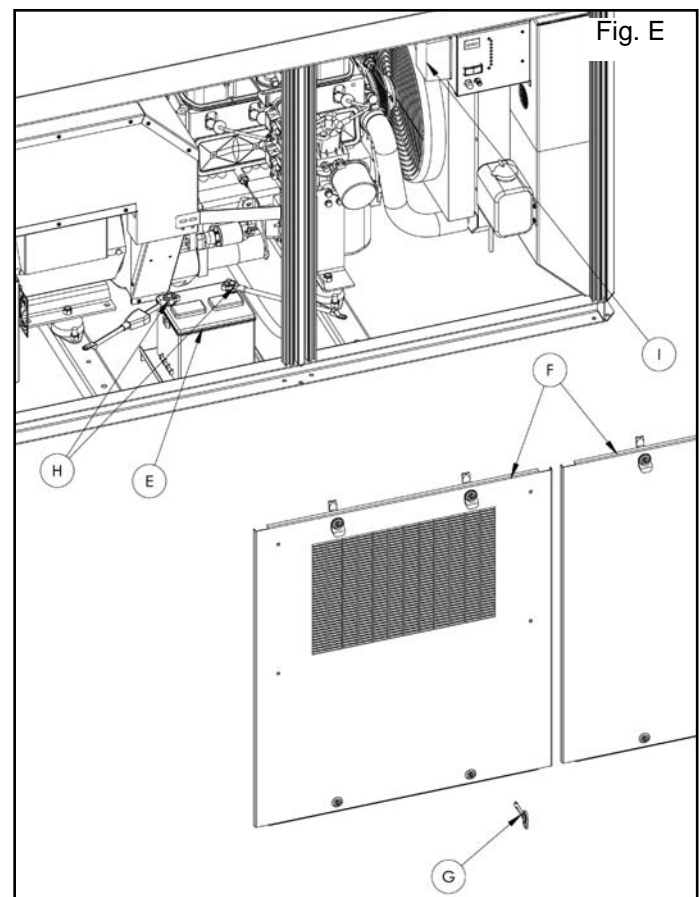

BATTERY MAINTENANCE (cont.)

Table A

Display		Operating Condition
Red		•When the red LED is on, it indicates that your battery is discharged and the charger is recharging at the "BULK" rate of 6 Amps. •While the red LED is on, the voltage measured will be 11.8 to 14 volts. •If the red LED stays on for more than 24 hours, refer to the troubleshooting section of this manual.
Green		•When both the green and the red LED's are on, the charger is charging at an "ABSORPTION" rate of between 1.5 and 5 Amps. This mode of charging gradually "tops off" the battery, and reduces harmful sulfating. •While both LED's are on, the voltage measured should be approx. 14.0 to 14.5VDC. •If both LED's stay on longer than 24 hours, refer to the troubleshooting section in this manual.
Red		•When the green LED is on, the charger is charging at a "FLOAT" rate of less than 1.5 Amps. •This "float" charging current will gradually decrease to as low as 0.1 Amps as the battery reaches 100% charge. It will now be kept at full charge without over-charging. •If the green LED stays on when the battery is known to be low, refer to the troubleshooting section of this manual.
Green		

SPARK PLUG CHECK

Engine spark plugs are an important part of the engine ignition system. Worn or incorrectly adjusted spark plugs can negatively affect engine starting and operation. Therefore, it is important to inspect and regap, or replace the engine spark plugs as indicated in the service interval table. The listed steps are recommended to access and service the engine spark plugs.

WARNING



- **Before performing any maintenance, make sure the Mode switch is in the OFF position, the circuit breaker is in the OFF position and the positive (red) battery cable is disconnected.**

1. Access the spark plugs (J) by removing the front and back generator panels (K). Insert the key (L) into the top locks and turn 1/4 turn counterclockwise to unlock. Lift the panels up and out of the base and set them aside. *Note: there is no need to turn the locks located on the bottom of the panel.*
2. Pull the spark plug boots loose, then clean any dirt from the area around the spark plugs. Remove the

spark plugs with a 5/8" spark plug wrench.

3. Inspect the spark plugs for fouling or abnormal wear like excessively worn electrodes or cracked or chipped insulator material. If abnormal wear is indicated, replace the spark plugs. Fouled plugs indicate the need for engine service by a qualified engine service technician. New spark plugs or plugs that do not display any abnormal characteristics should be checked for proper gap using a suitable spark plug gauge. Adjust the gap to .035 inches (.889 mm) by carefully bending the grounding electrode.
4. Reinstall the spark plugs by hand until they begin to seat to avoid cross-threading. After the plugs begin to seat, tighten plugs an additional 1/4 turn with a 5/8" spark plug wrench to avoid damage to the spark plugs. If a torque wrench is available, tighten all plugs to **13 in-lbs (18 N-m)**.
5. Reassemble the front and back panels (K) to the generator by setting the bottom end of the panel into the base and push into place. Insert the key (L) into the top locks and turn 1/4 turn clockwise to lock.

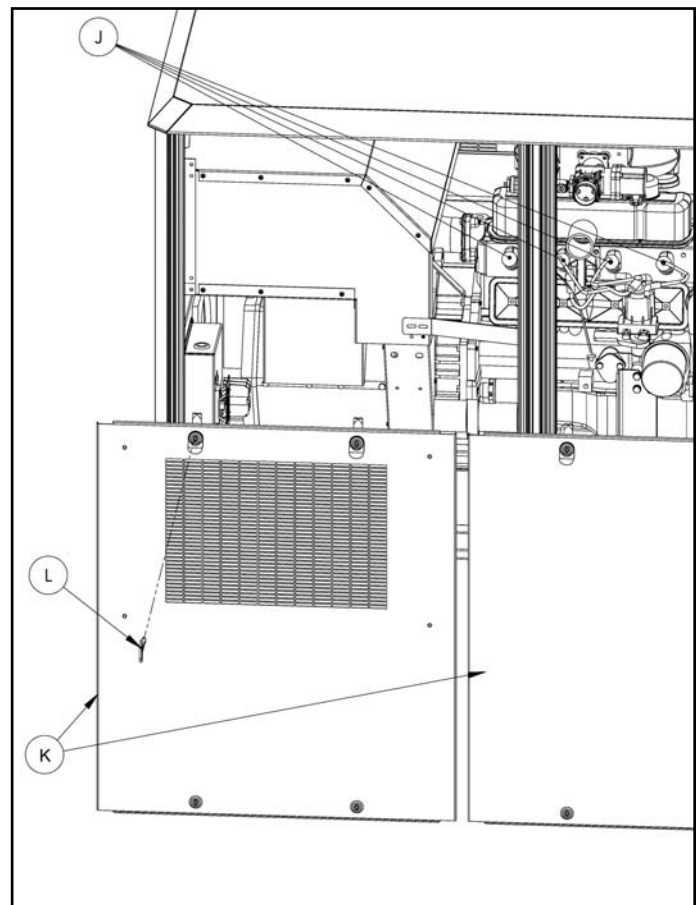

ENCLOSURE AND SITE

Proper cooling of the generator is vital to maintain performance and prevent equipment failure. Blocked cabinet openings or other airflow obstructions are potential fire hazards and can cause failures. Periodically inspect generator cabinet openings and the engine oil cooler for blockages. Do not allow leaves, grass, dirt, snow or other objects to build up around the cabinet. Keep plants and other landscaping groomed to allow a minimum of three feet or greater of open space around all sides of the generator (*check your local building codes for clearance requirements for your area*). **Do not place a cover over the generator.**

DANGER



- Generator exhaust air contains carbon monoxide, a deadly odorless, colorless and tasteless gas. Breathing carbon monoxide causes severe nausea, fainting or death. Do not allow exhaust air to enter a building through windows, doors, air intakes or other means. Avoid breathing exhaust air while operating or servicing the generator set. The engine exhaust from this product contains chemicals known to the State of California to cause cancer, birth defects, or other reproductive harm.

CAUTION

- Covering or restricting the air passages on the generator will cause the unit to overheat and may create a fire hazard. Do not allow snow or leaves to cover enclosure openings.
- Leave a three foot or greater open area around all sides of the unit. *Check your local building codes for clearance requirements for your area.* Do not plant trees or plants close to the unit.
- Unit should be located to prevent combustible material from accumulating against the generator.
- The generator **MUST** be installed outdoors.

VALVE CLEARANCE CHECK AND ADJUSTMENT

Over time, normal engine operation leads to wear in the engine valve train which decreases generator output. To restore generator output, it is necessary to check and adjust the engine valve lash at regular intervals throughout the life of the engine. However, proper valve lash adjustments require specialized training and tools. Adjustment by persons unfamiliar with the procedure can cause damage to the engine not covered under warranty. Contact an authorized generator dealer for assistance in locating qualified service personnel.

CAUTION

- This adjustment should only be performed by trained personnel. If incorrect adjustments are made, the unit may fail to operate or operate inefficiently.

FUEL SYSTEM INSPECTION

Avoid explosive and potentially lethal fuel leaks by inspecting the complete generator fuel supply system at intervals no greater than those listed in the Maintenance Table on page 21. Visually inspect all hoses for cracks, splits, or brittleness and replace hoses that show these or other signs of wear. Check all connections for tightness and cracks, replacing any broken fittings or clamps. Check all connections for leaks, while the generator is running, using approved equipment and methods. **DO NOT** use a flame to check for leaks.

WARNING



- Extreme caution should be taken while performing general maintenance.
- Do not smoke when near the unit.
- Keep flames, sparks, pilot lights, arc-producing equipment, switches and all other sources of ignition well away. Keep a type ABC fire extinguisher handy.
- Do Not operate engine if smell of fuel is present or other explosive conditions exist.
- Do Not use a flame to check for leaks.

TROUBLESHOOTING

SYMPTOM	POSSIBLE CAUSE	CORRECTIVE ACTION		
Engine does not crank	Loose battery cables	<ul style="list-style-type: none"> • Check all battery cable connections. 		
	Defective battery	<ul style="list-style-type: none"> • Test battery. Replace as necessary. 		
	Improper battery charger function	<ul style="list-style-type: none"> • Ensure charger is plugged into receptacle. • Check for tripped main circuit. Reset if required. • Check all charger cable connections for cleanliness and tightness. • Check charger lights to verify correct operation. See Table A, Page 25. 		
		Fault in starter signal circuit	<ul style="list-style-type: none"> • Contact a qualified generator dealer for service assistance. 	
		Blown control circuit fuse	<ul style="list-style-type: none"> • Check control circuit fuse. 	
	Engine cranks without starting	Low battery	<ul style="list-style-type: none"> • Test battery. Replace as necessary. • Ensure charger is plugged into receptacle. • Check for tripped main circuit breaker. Reset if required. • Check all charger cable connections for cleanliness and tightness. • Check charger lights to verify correct operation. See Table A, Page 25. 	
Poor fuel supply			<ul style="list-style-type: none"> • Ensure all manual shutoff valves are open. • Check for proper fuel supply pressure. • Verify size and fill level of propane tank (LPG only). • Check fuel solenoid voltage during cranking. 	
			Low oil pressure	<ul style="list-style-type: none"> • Check engine oil level. • Check switch for proper function.
				High engine temperature
No generator output			Main line circuit breaker tripped	
		Disconnect breaker tripped	<ul style="list-style-type: none"> • Check for tripped breaker in circuit between generator output and transfer switch. Clear fault, then reclose breaker. 	
		Generator loss of excitation	<ul style="list-style-type: none"> • Contact a qualified generator dealer for service assistance. 	
		Excitation capacitor failure	<ul style="list-style-type: none"> • Contact a qualified generator dealer for service assistance. 	
	Generator diode or varistor failure	<ul style="list-style-type: none"> • Contact a qualified generator dealer for service assistance. 		
	Generator head fault	<ul style="list-style-type: none"> • Contact a qualified generator dealer for service assistance. 		

TROUBLESHOOTING

SYMPTOM	POSSIBLE CAUSE	CORRECTIVE ACTION
Low generator output voltage	Excitation capacitor failure	• Contact a qualified generator dealer for service assistance.
	Generator diode or varistor failure	• Contact a qualified generator dealer for service assistance.
Overspeed light stays lit	Shutdown due to high engine speed	• Verify correct engine speed setting.
Underspeed light stays lit	Shutdown due to low engine speed	• Reduce loads connected to generator.
Overcrank light stays lit	Failure to start	• See "Engine cranks without starting".
Not In Auto light stays lit	Generator not set for unattended operation	• Place mode switch into AUTO position if automatic function is required.
Low oil pressure light stays lit	Shutdown due to low engine oil pressure	• Check engine oil level.
		• Verify correct type of engine oil for ambient temperature conditions.
Low battery light stays lit	Low battery	• Test battery. Replace as necessary.
		• Ensure charger is plugged into receptacle.
		• Check for tripped main circuit breaker. Reset if required.
		• Check all charger cable connections for cleanness and tightness.
		• Check battery charger inline fuse.
		• Check charger lights to verify correct operation. See Table A, Page 25.
High engine temperature light stays lit	Shutdown due to high engine temperature	• Allow engine to cool, then restart.
		• Decrease loads on generator.
		• Check enclosure openings for blockage.
		• Check radiator coolant level.

POWERSTATION[®] Automated Power System Limited Warranty

Warranty: Powermate Corporation warrants to the original consumer purchaser in the U.S. or Canada that it will repair or replace any parts or components found to be defective in material or workmanship. The product must be properly installed and maintained in accordance with operator's manuals, and must be used solely as emergency stand-by power to a utility-supplied primary power system. Warranty service must be performed by an authorized service center.

Warranty Period:

Comprehensive: Covers the entire unit (including engine and alternator) for three (3) years or 1500 hours of operation, whichever occurs first, from the date of purchase. This warranty covers the cost of parts and labor to repair or replace defective parts.

Extended Warranty on Engine/Alternator: Covers the engine and alternator for five (5) years or 1500 hours of operation, whichever occurs first, from the date of purchase. If repair or replacement of defective engine/alternator parts or components is needed after the first three years, Powermate will provide or pay for the replacement parts or components. (Labor not included.)

For warranty service, the customer must provide dated proof of purchase and must notify Powermate within the warranty period. This warranty is not transferable.

Not Covered: The following are not covered by the warranty:

- Routine maintenance and tune-ups; replacement of normal maintenance items such as filters, spark plugs, fuses, or lamps; or consumables such as fuel, oil or coolant/antifreeze;
- Starting batteries, or service associated with battery failure;
- Damages or repairs caused by:
 - ~ Improper installation
 - ~ Improper maintenance, or failure to maintain and service the product according to the operating instructions
 - ~ Operation with improper fuels or lubricants, or at speeds, loads, or conditions contrary to operating instructions
 - ~ Abuse, accident, theft, vandalism, acts of God or other external causes;
- Overtime charges during repair or air freight shipping charges incurred at the customer's request, unless done with Powermate's prior approval.

Warranty is void (i) if the product is modified or altered contrary to published specifications, (ii) if repairs are performed by anyone other than Powermate-authorized service center or with parts other than Powermate-approved parts, or (ii) where the generator is used as a primary power source or as back up for solar, wind-power or other alternative power system.

For warranty service: Call toll free 866-769-3703, or write to Powermate Corporation, Product Services, 4970 Airport Road, Kearney, NE 68848.

EXCLUSIONS AND LIMITATIONS: THE COMPANY MAKES NO OTHER WARRANTY OF ANY KIND, EXPRESS OR IMPLIED. IMPLIED WARRANTIES, INCLUDING WARRANTIES OF MERCHANTABILITY AND OF FITNESS FOR A PARTICULAR PURPOSE, ARE HEREBY DISCLAIMED. THE WARRANTY SERVICE DESCRIBED ABOVE IS THE EXCLUSIVE REMEDY UNDER THIS WARRANTY; LIABILITY FOR INCIDENTAL AND CONSEQUENTIAL DAMAGES IS EXCLUDED TO THE EXTENT PERMITTED BY LAW.

This warranty gives you specific legal rights, and you may also have other rights which vary from state to state. Some states do not allow a disclaimer of implied warranties, or the exclusion or limitation of incidental and consequential damages, so the above disclaimers and exclusions may not apply to you.



**CONTACT THE POWERMATE PRODUCT SERVICE DEPARTMENT AT
1-866-769-3703**

to obtain warranty service information or to order replacement parts or accessories.

HOW TO ORDER REPLACEMENT PARTS

Even quality built equipment such as the Powermate standby generator you have purchased, might need occasional replacement parts to maintain it in good condition over the years. To order replacement parts, please give the following information:

1. Model No. and Serial No. and all specifications shown on the Model No./Serial No. plate.
2. A brief description of the trouble with the generator.

**Powermate Corporation
4970 Airport Road
P. O. Box 6001
Kearney, NE 68848
1-866-769-3703
1-308-237-2181
Fax 1-308-234-4187**

Made in USA with domestic and foreign components
Powermate Corporation, Aurora, IL 60504
©2007 Powermate Corporation

All Rights Reserved. Tous droits réservés. Reservados todos los derechos.

Powermate® is a registered trademark of Powermate Corporation.
Powermate® est une marque déposée de Powermate Corporation.
Powermate® es una marca comercial registrada de Powermate Corporation.

PowerStation® is a registered trademark of Powermate Corporation.
PowerStation® est une marque déposée de Powermate Corporation.
PowerStation® es una marca comercial registrada de Powermate Corporation.

Free Manuals Download Website

<http://myh66.com>

<http://usermanuals.us>

<http://www.somanuals.com>

<http://www.4manuals.cc>

<http://www.manual-lib.com>

<http://www.404manual.com>

<http://www.luxmanual.com>

<http://aubethermostatmanual.com>

Golf course search by state

<http://golfingnear.com>

Email search by domain

<http://emailbydomain.com>

Auto manuals search

<http://auto.somanuals.com>

TV manuals search

<http://tv.somanuals.com>