

POWERMATIC®

Operating Instructions and Parts Manual 20" and 24" Band Saws Models 2013 and 2415



*For model 2013 serial no. 13102013913 and higher.
For model 2415 serial no. 140224151098 and higher.*

Powermatic
427 New Sanford Rd.
LaVergne, TN 37086
Ph.: 800-274-6848
www.powermatic.com

Part No. M-1791257
Revision E2 10/2014
Copyright © 2014 Powermatic

Warranty and Service

Powermatic warrants every product it sells against manufacturers' defects. If one of our tools needs service or repair, please contact Technical Service by calling 1-800-274-6846, 8AM to 5PM CST, Monday through Friday.

Warranty Period

The general warranty lasts for the time period specified in the literature included with your product or on the official Powermatic branded website.

- Powermatic products carry a limited warranty which varies in duration based upon the product. (See chart below)
- Accessories carry a limited warranty of one year from the date of receipt.
- Consumable items are defined as expendable parts or accessories expected to become inoperable within a reasonable amount of use and are covered by a 90 day limited warranty against manufacturer's defects.

Who is Covered

This warranty covers only the initial purchaser of the product from the date of delivery.

What is Covered

This warranty covers any defects in workmanship or materials subject to the limitations stated below. This warranty does not cover failures due directly or indirectly to misuse, abuse, negligence or accidents, normal wear-and-tear, improper repair, alterations or lack of maintenance. Powermatic woodworking machinery is designed to be used with Wood. Use of these machines in the processing of metal, plastics, or other materials may void the warranty. The exceptions are acrylics and other natural items that are made specifically for wood turning.

Warranty Limitations

Woodworking products with a Five Year Warranty that are used for commercial or industrial purposes default to a Two Year Warranty. Please contact Technical Service at 1-800-274-6846 for further clarification.

How to Get Technical Support

Please contact Technical Service by calling 1-800-274-6846. **Please note that you will be asked to provide proof of initial purchase when calling.** If a product requires further inspection, the Technical Service representative will explain and assist with any additional action needed. Powermatic has Authorized Service Centers located throughout the United States. For the name of an Authorized Service Center in your area call 1-800-274-6846 or use the Service Center Locator on the Powermatic website.

More Information

Powermatic is constantly adding new products. For complete, up-to-date product information, check with your local distributor or visit the Powermatic website.

How State Law Applies

This warranty gives you specific legal rights, subject to applicable state law.

Limitations on This Warranty

POWERMATIC LIMITS ALL IMPLIED WARRANTIES TO THE PERIOD OF THE LIMITED WARRANTY FOR EACH PRODUCT. EXCEPT AS STATED HEREIN, ANY IMPLIED WARRANTIES OF MERCHANTABILITY AND FITNESS FOR A PARTICULAR PURPOSE ARE EXCLUDED. SOME STATES DO NOT ALLOW LIMITATIONS ON HOW LONG AN IMPLIED WARRANTY LASTS, SO THE ABOVE LIMITATION MAY NOT APPLY TO YOU.

POWERMATIC SHALL IN NO EVENT BE LIABLE FOR DEATH, INJURIES TO PERSONS OR PROPERTY, OR FOR INCIDENTAL, CONTINGENT, SPECIAL, OR CONSEQUENTIAL DAMAGES ARISING FROM THE USE OF OUR PRODUCTS. SOME STATES DO NOT ALLOW THE EXCLUSION OR LIMITATION OF INCIDENTAL OR CONSEQUENTIAL DAMAGES, SO THE ABOVE LIMITATION OR EXCLUSION MAY NOT APPLY TO YOU.

Powermatic sells through distributors only. The specifications listed in Powermatic printed materials and on the official Powermatic website are given as general information and are not binding. Powermatic reserves the right to effect at any time, without prior notice, those alterations to parts, fittings, and accessory equipment which they may deem necessary for any reason whatsoever.

Product Listing with Warranty Period

90 Days – Parts; Consumable items
1 Year – Motors, Machine Accessories
2 Year – Woodworking Machinery used for industrial or commercial purposes
5 Year – Woodworking Machinery

NOTE: Powermatic is a division of JPW Industries, Inc. References in this document to Powermatic also apply to JPW Industries, Inc., or any of its successors in interest to the Powermatic brand.

Table of Contents

Warranty and Service.....	2
Table of Contents.....	3
Warning.....	5
Introduction.....	7
Specifications.....	7
Features and Terminology.....	8
Floor Diagrams.....	8
Unpacking.....	9
Contents of the Shipping Container.....	9
Assembly.....	10
Installing Fence and Rails.....	10
Dust Collection.....	12
Grounding Instructions.....	12
Extension cords.....	13
230 Volt, Single Phase Operation.....	13
230 Volt, Three Phase Operation.....	13
Converting from 230 Volt to 460 Volt (Three Phase Only).....	14
Three-Phase Test Run.....	14
Adjustments.....	15
Table Tilt.....	15
90° Table Stop.....	15
Installing/Changing Blades.....	16
Blade Tension.....	16
Blade Tracking.....	17
Upper Blade Guide Assembly.....	18
Upper Blade Guides and Upper Support Bearing.....	18
Lower Blade Guides and Lower Support Bearing.....	19
Miter Gauge.....	20
Belt Tension.....	20
Belt Alignment.....	21
Blade Speed Adjustment.....	21
Operating Controls.....	21
Brake Pedal.....	22
Operation.....	22
General Procedure.....	22
Ripping.....	23
Crosscutting.....	23
Resawing.....	23
Blade Lead.....	23
Blade Selection.....	24
Width.....	25
Pitch.....	25
Shape.....	25
Set.....	26
Material.....	26
Blade Breakage.....	26
Maintenance.....	27
Tire Replacement.....	27
Band Wheel Replacement.....	27
Blade Selection Guide.....	28
For Radius Cutting.....	28
Troubleshooting – Operational Problems.....	29
Troubleshooting – Mechanical and Electrical Problems.....	31
Replacement Parts.....	32
Parts List: Saw Body Assembly (2013 Band Saw).....	33
Parts List: Saw Body Assembly (2415 Band Saw).....	34
Saw Body Assembly (2013 and 2415).....	35
Parts List: Table Assembly (2013 Band Saw).....	36
Parts List: Table Assembly (2415 Band Saw).....	38
Table Assembly (2013 and 2415).....	40
Parts List: Upper Wheel Base Assembly (2013 Band Saw).....	41
Parts List: Upper Wheel Base Assembly (2415 Band Saw).....	42

Upper Wheel Base Assembly (2013 and 2415)	43
Parts List: Lower Wheel Base Assembly (2013 Band Saw).....	44
Parts List: Lower Wheel Base Assembly (2415 Band Saw).....	46
Lower Wheel Base Assembly (2013 and 2415)	48
Parts List: Guide Bracket Assembly (2013 Band Saw)	49
Parts List: Guide Bracket Assembly (2415 Band Saw)	51
Guide Bracket Assembly (2013 and 2415).....	53
Electrical Connections: 230 Volt, Single Phase – Model 2013 Band Saw ONLY	54
Electrical Connections: 230 Volt, Single Phase – Model 2415 Band Saw ONLY	55
Electrical Connections: 230 Volt, 3 Phase – Models 2013 and 2415.....	56
Electrical Connections: 460 Volt, 3 Phase – Models 2013 and 2415.....	57



Warnings

1. Read and understand the entire owner's manual before attempting assembly or operation.
2. Read and understand the warnings posted on the machine and in this manual. Failure to comply with all of these warnings may cause serious injury.
3. Replace the warning labels if they become obscured or removed.
4. This band saw is designed and intended for use by properly trained and experienced personnel only. If you are not familiar with the proper and safe operation of a band saw, do not use until proper training and knowledge have been obtained.
5. Do not use this band saw for other than its intended use. If used for other purposes, Powermatic disclaims any real or implied warranty and holds itself harmless from any injury that may result from that use.
6. Always wear approved safety glasses/face shields while using this band saw. Everyday eyeglasses only have impact resistant lenses; they are not safety glasses.
7. Before operating this band saw, remove tie, rings, watches and other jewelry, and roll sleeves up past the elbows. Remove all loose clothing and confine long hair. Non-slip footwear or anti-skid floor strips are recommended. Do **not** wear gloves.
8. Wear ear protectors (plugs or muffs) during extended periods of operation.
9. Some dust created by power sanding, sawing, grinding, drilling and other construction activities contain chemicals known to cause cancer, birth defects or other reproductive harm. Some examples of these chemicals are:
 - Lead from lead based paint.
 - Crystalline silica from bricks, cement and other masonry products.
 - Arsenic and chromium from chemically treated lumber.Your risk of exposure varies, depending on how often you do this type of work. To reduce your exposure to these chemicals, work in a well-ventilated area and work with approved safety equipment, such as face or dust masks that are specifically designed to filter out microscopic particles.
10. Do not operate this machine while tired or under the influence of drugs, alcohol or any medication.
11. Make certain the switch is in the **OFF** position before connecting the machine to the power supply.
12. Make certain the machine is properly grounded.
13. Make all machine adjustments or maintenance with the machine unplugged from the power source.
14. Remove adjusting keys and wrenches. Form a habit of checking to see that keys and adjusting wrenches are removed from the machine before turning it on.
15. Keep safety guards in place at all times when the machine is in use. If removed for maintenance purposes, use extreme caution and replace the guards immediately.
16. Check damaged parts. Before further use of the machine, a guard or other part that is damaged should be carefully checked to determine that it will operate properly and perform its intended function. Check for alignment of moving parts, binding of moving parts, breakage of parts, mounting and any other conditions that may affect its operation. A guard or other part that is damaged should be properly repaired or replaced.
17. Provide for adequate space surrounding work area and non-glare, overhead lighting.
18. Keep the floor around the machine clean and free of scrap material, oil and grease.
19. Keep visitors a safe distance from the work area. **Keep children away.**
20. Make your workshop child proof with padlocks, master switches or by removing starter keys.



Warnings

21. Give your work undivided attention. Looking around, carrying on a conversation and “horse-play” are careless acts that can result in serious injury.
22. Maintain a balanced stance at all times so that you do not fall or lean against the blade or other moving parts. Do not overreach or use excessive force to perform any machine operation.
23. Use the right tool at the correct speed and feed rate. Do not force a tool or attachment to do a job for which it was not designed. The right tool will do the job better and safer.
24. Use recommended accessories; improper accessories may be hazardous.
25. Maintain tools with care. Keep blade sharp and clean for the best and safest performance. Follow instructions for lubricating and changing accessories.
26. Turn off the machine before cleaning. Use a brush or compressed air to remove chips or debris — do not use your hands.
27. Do not stand on the machine. Serious injury could occur if the machine tips over.
28. Never leave the machine running unattended. Turn the power off and do not leave the machine until it comes to a complete stop.
29. Remove loose items and unnecessary work pieces from the area before starting the machine.

Familiarize yourself with the following safety notices used in this manual:



CAUTION This means that if precautions are not heeded, it may result in minor injury and/or possible machine damage.



WARNING This means that if precautions are not heeded, it may result in serious injury or possibly even death.

- - SAVE THESE INSTRUCTIONS - -

Introduction

This manual is provided by Powermatic covering the safe operation and maintenance procedures for a Powermatic Model 2013 or 2415 Band Saw. This manual contains instructions on installation, safety precautions, general operating procedures, maintenance instructions and parts breakdown. This machine has been designed and constructed to provide years of trouble free operation if used in accordance with instructions set forth in this manual. If there are any questions or comments, please contact either your local supplier or Powermatic. Powermatic can also be reached at our web site: www.powermatic.com.

Specifications

Model Number	2013	2415
Stock Number (2HP, 1PH, 230V).....	1791257	na
Stock Number (3HP, 1PH, 230V).....	na	1791259
Stock Number (3HP, 3PH, 230/460V*)	1791258	na
Stock Number (5HP, 3PH, 230/460V*)	na	1791260
Blade Speeds (SFPM)	2,000 and 4,000	2,000 and 4,000
Thickness Capacity, Maximum (in.)	12-3/8	14-3/8
Width Capacity, Maximum (in.)	20	24
Table Size (in.)	24 x 24	24 x 28
Table Tilt (deg.)	45 right, 10 left	45 right, 10 left
Approximate Blade Length (in.).....	158-1/2	180-1/2
Blade Widths (in.).....	1/4 minimum, 1-1/2 maximum	1/4 minimum, 1-1/2 maximum
Switch.....	magnetic	magnetic
Dust Collection Minimum CFM Required	600	600
Table Height at 90° (in.)	35-1/4	35-3/8
Floor Space Required (in.)	39 x 45-1/2	39 x 51-1/2
Shipping Weight (lbs.)	970	1190

* pre-wired 230 volt **NOTE:** For 460V operation, magnetic switch (part no. 2013-102D for model 2013; and part no. 2415-102D for model 2415) must be purchased separately and installed. A qualified electrician is recommended.

The above specifications were current at the time this manual was published, but because of our policy of continuous improvement, Powermatic reserves the right to change specifications at any time and without prior notice, without incurring obligations.

Features and Terminology

(Model 2415 shown)

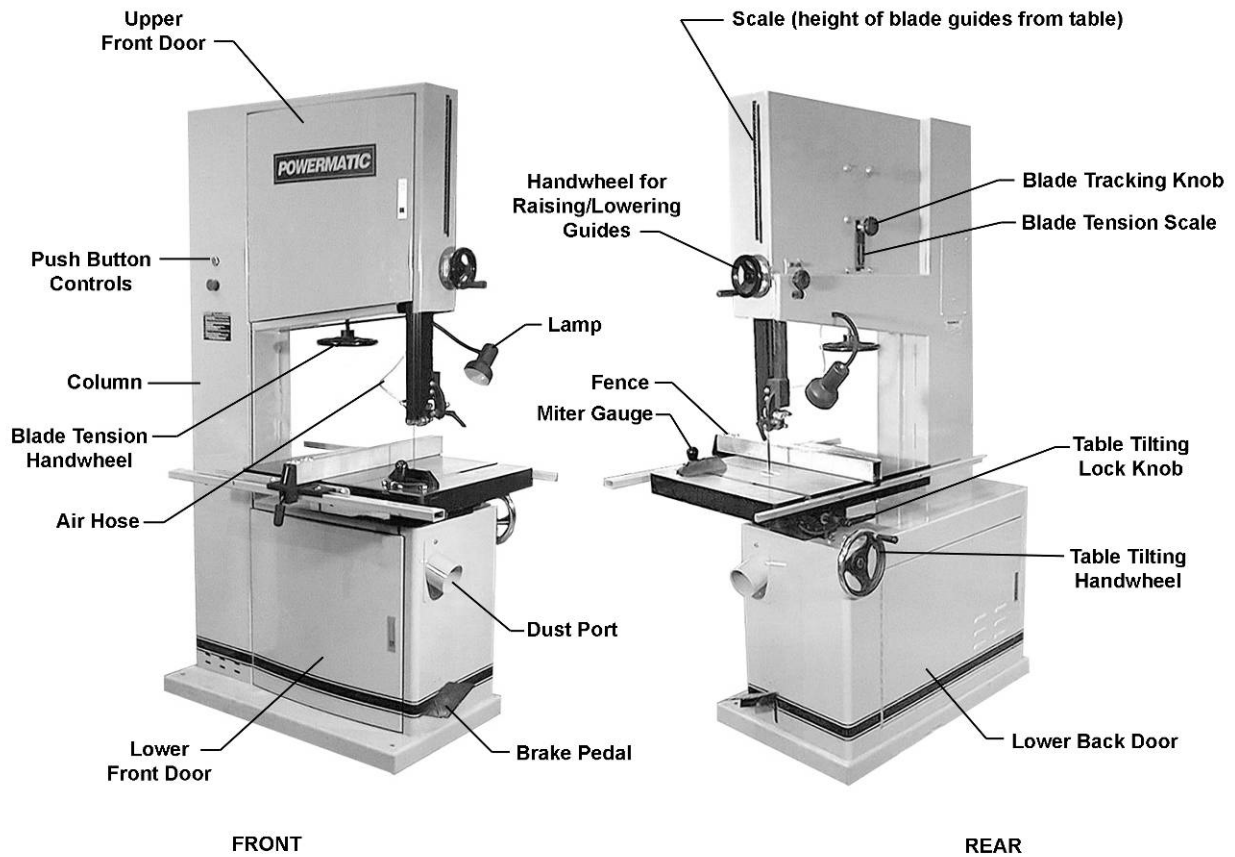

Floor Diagrams

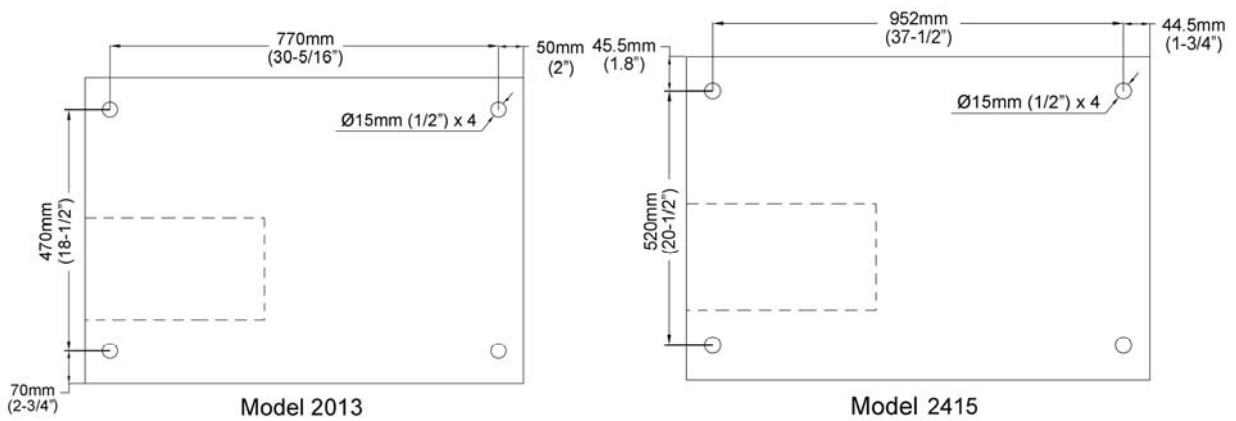

Unpacking

Open shipping container and check for shipping damage. Report any damage immediately to your distributor and shipping agent. Do not discard any shipping material until the Band Saw is set up and running properly.

Compare the contents of your container with the following parts list to make sure all parts are intact. Missing parts, if any, should be reported to your distributor. Read the instruction manual thoroughly for assembly, maintenance and safety instructions.

Contents of the Shipping Container

- 1 Band Saw
- 1 Miter Gauge
- 1 Front Rail
- 1 Rear Rail
- 1 Guide Rail
- 1 Fence
- 1 Fence Body
- 1 Combination Wrench - 10/12mm
- 1 Bag of Fasteners, containing:
 - 2 Hex Cap Screws, 5/16-18 x 1-1/4"
 - 4 Hex Cap Screws, 5/16-18 x 3/4"
 - 6 Flat Washers, 5/16"
 - 6 Lock Washers, 5/16"
 - 7 Hex Cap Screws, 1/4-20 x 5/8"
 - 7 Flat Washers, 1/4"
 - 7 Lock Washers, 1/4"
- 1 Owner's Manual
- 1 Warranty Card

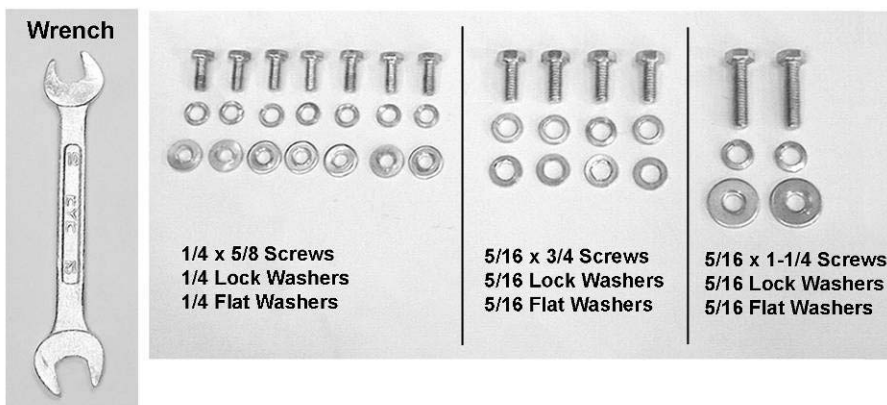
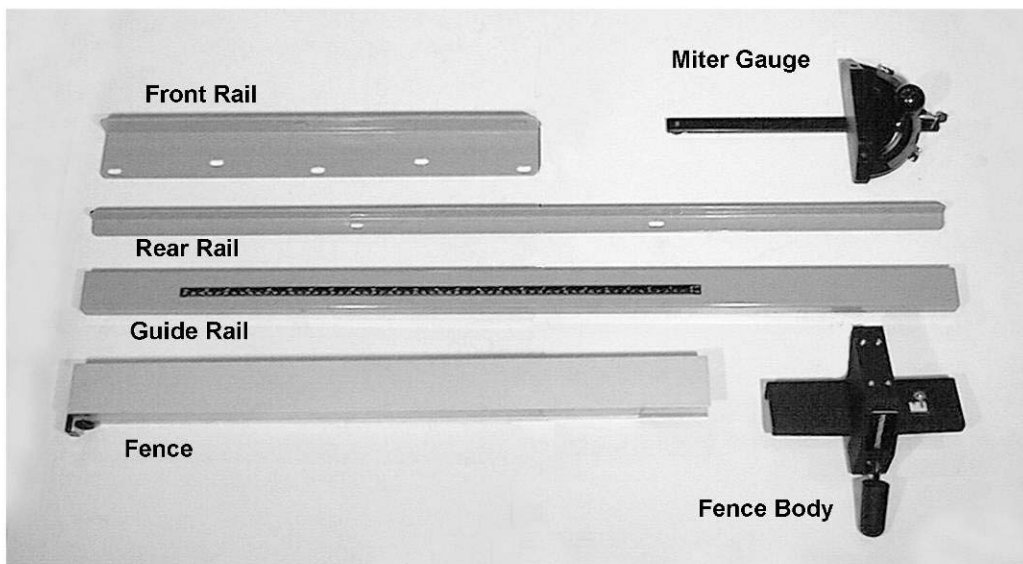

⚠ WARNING

Read and understand the entire contents of this manual before attempting set-up or operation! Failure to comply may cause serious injury.

Assembly

Tools required for assembly:

Forklift or hoist with straps
10-12mm wrench (provided)
14mm wrench

(NOTE: A socket wrench set may speed assembly time)

Remove all crating and plastic from around the band saw. Remove any lag screws or holding straps which secure the band saw to the wood pallet.

Use a hoist or forklift with straps to lift the band saw from the pallet. Position the strap as shown in Figure 1. (Do NOT place forks or straps directly under the band saw table to lift it.) Move the band saw to its permanent location, which should be dry and well lit, with enough space on all sides to handle long stock or perform routine maintenance on the machine. Make sure the floor is able to support the weight of the machine.

Areas of the Band Saw have been given a protective coating at the factory. This should be removed with a soft cloth moistened with kerosene or mineral spirits. Do not get solvents near plastic or rubber parts, and do not use an abrasive pad as it may scratch metal surfaces.



Figure 1

Installing Fence and Rails

1. Mount the front rail (A, Figure 1a) to the saw table with two 5/16 x 1-1/4 hex cap screws, two 5/16 lock washers, and two 5/16 flat washers. Screws should be placed horizontally in approximately the center of the slot. Hand tighten the screws.
2. Mount the rear rail (B, Figure 1a) to the table with two 1/4 x 5/8 hex cap screws, two 1/4 lock washers, and two 1/4 flat washers. Hand tighten the screws.
3. Push the front and rear rails upward (toward the table top) as far as they will go.
4. Tighten the two hex cap screws holding the front rail to the table, with a 12mm wrench. Tighten the two hex cap screws holding the rear rail to the table with a 10mm wrench.
5. Attach the guide rail (C, Figure 1a) to the front rail with five 1/4 x 5/8 hex cap screws, five 1/4 lock washers, and five 1/4 flat washers. The scale on the guide rail should face toward the operator. Hand tighten the screws only.

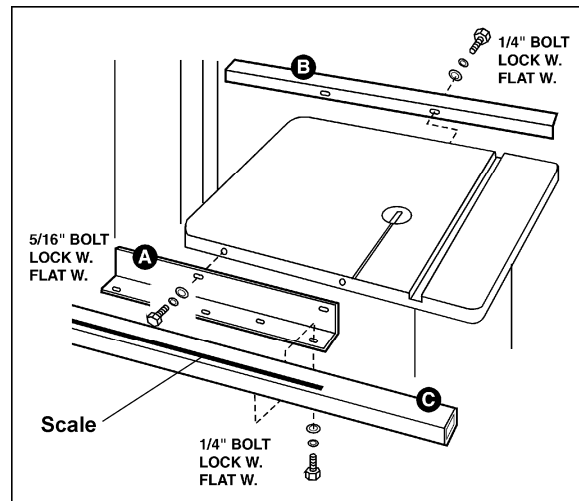

Figure 1a

6. Attach the fence (D, Figure 2) to the fence body (E, Figure 2) with four 5/16 x 3/4 hex cap screws, four 5/16 lock washers, and four 5/16 flat washers. Hand tighten the screws only.
7. Place the fence assembly onto the guide rail and against the edge of the miter slot, as shown in Figure 2. The hook at the rear of the fence should fit under the rear rail (see Figure 5).
8. The fence must align parallel to the miter slot along the entire length of the fence.
9. Lock the fence by pushing down the lock handle (G, Figure 2). Because the screws are only hand-tight, you can shift the fence slightly as needed until the fence parallels the miter slot.

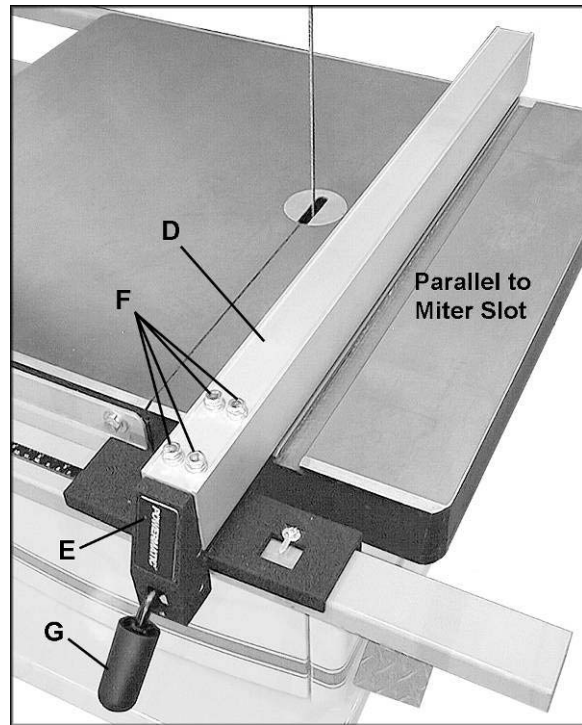

Figure 2

10. When the fence has been properly aligned to the miter slot, tighten the four hex cap screws (F, Figure 2) with a 12mm wrench. Make sure the fence remains parallel to the miter slot as you tighten the screws. (NOTE: This alignment will again be checked once the guide rail has been tightened.)
11. Move the fence assembly to the other side of the blade so that the pointer (Figure 3) on the fence body points to "zero" on the scale. Lock the fence by pushing the handle down.
12. Move the guide rail with the locked fence until the fence is flush against the blade. (Do not force the fence into the blade so that the blade bends.) See Figure 3. Do not unlock the fence to perform this. Move the fence and guide rail together when establishing the zero point.
13. Tighten the five hex cap screws that hold the guide rail to the front rail, with a 10mm wrench. NOTE: After tightening the guide rail, double check that the fence is still parallel to the miter slot. Make additional adjustments if needed.

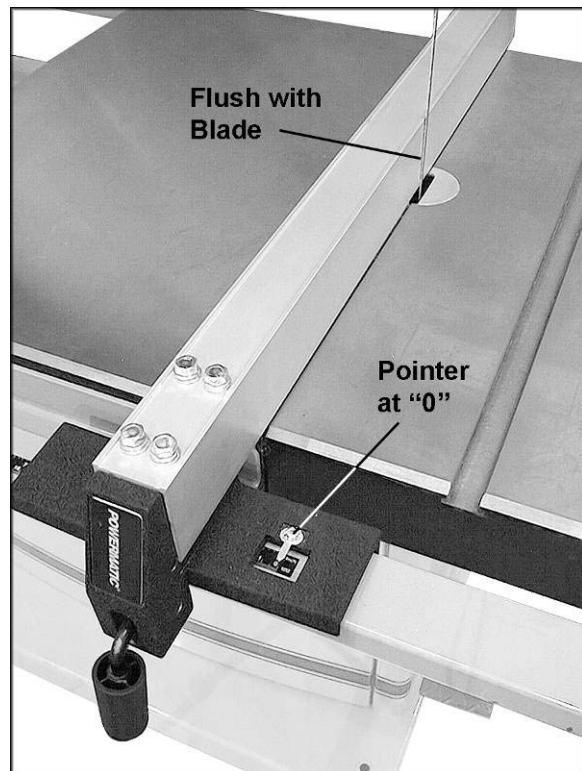

Figure 3

14. Check the clearance between the table and the fence. The fence should not rub against the table surface but be slightly above it. This gap should be the same at the front of the table as it is at the rear. See Figure 4.
15. If the gap between fence and table is not consistent, loosen either of the hex nuts on the hook (Figure 5) and rotate the sliding pad until the fence/table gap is consistent across the full length of the table. When this is achieved, tighten both hex nuts.
16. Check the adjustment of the hook at the rear of the fence. The hook should be positioned so that it overlaps the rear rail by approximately 1/8". See Figure 5. To adjust the hook, loosen the upper hex nut (Figure 6) and slide the hook in or out as needed. Re-tighten upper hex nut.

Dust Collection

The use of a dust collection system is strongly recommended for this band saw. It will help keep the shop clean as well as reduce any potential health hazards caused by inhalation of wood dust. The collector should have a capacity sufficient for this size machine (minimum of 600 CFM).

Attach the hose of the dust collector to the 4" dust port below the band saw table (Figure 6). Secure with a hose clamp or duct tape.

NOTE: Dryer vent hose is not acceptable for wood dust collection.

Grounding Instructions

⚠WARNING Electrical connections must be made by a qualified electrician in compliance with all relevant codes. This machine must be properly grounded to help prevent electrical shock and possible fatal injury.

This machine must be grounded. In the event of a malfunction or breakdown, grounding provides a path of least resistance for electric current to reduce the risk of electric shock.

Improper connection of the equipment-grounding conductor can result in a risk of electric shock. The conductor with insulation having an outer surface that is green with or without yellow stripes, is the equipment-grounding conductor. If repair or replacement of the electric cord or plug is necessary, do not connect the equipment-grounding conductor to a live terminal.

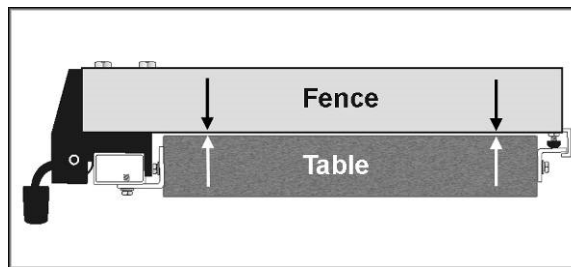

Figure 4

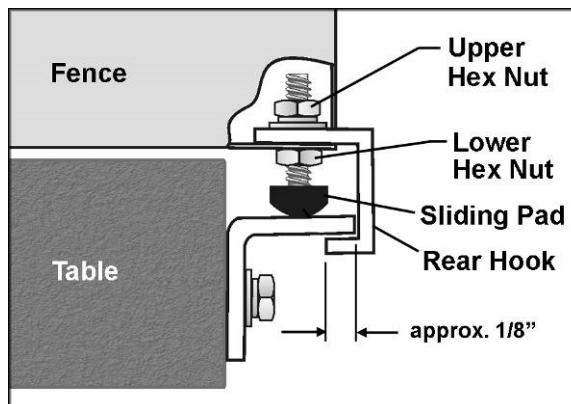

Figure 5

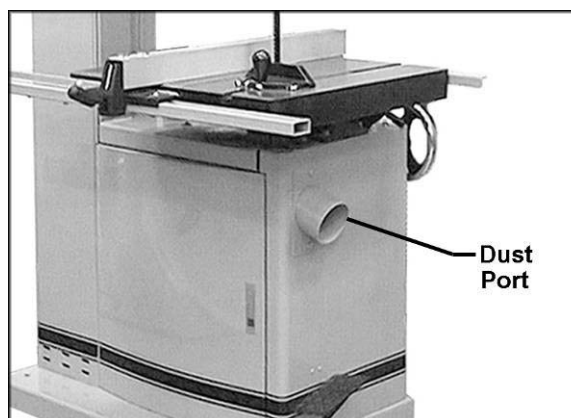

Figure 6

Check with a qualified electrician or service personnel if the grounding instructions are not completely understood, or if in doubt as to whether the tool is properly grounded.

Repair or replace a damaged or worn cord immediately.

Make sure the voltage of your power supply matches the specifications on the motor plate of the Band Saw. The machine should be connected to a dedicated circuit, and protected by a circuit breaker or time delay fuse, with minimum amp ratings as shown in Table 1. **Local codes take precedence over recommendations.**

Model	Recommended circuit*
1791257 (2HP 1PH 230V)	30 Amp
1791258 (3HP 3PH 230V)	30 Amp
1791258 (3HP 3PH 460V)	15 Amp
1791259 (3HP 1PH 230V)	30 Amp
1791260 (5HP 3PH 230V)	40 Amp
1791260 (5HP 3PH 460V)	20 Amp

*subject to local codes

Table 1

Extension cords

The use of an extension cord is not recommended for the 2013 or 2415 Band Saw. But if one is necessary, make sure the cord rating is suitable for the amperage listed on the machine's motor plate. An undersized cord will cause a drop in line voltage resulting in loss of power and overheating.

Use the chart in Figure 7 as a general guide in choosing the correct size cord. If in doubt, use the next heavier gauge. The smaller the gauge number, the heavier the cord.

230 Volt, Single Phase Operation

As received from the factory, the **single-phase** model of the Band Saw is designed to run on 230 volt power. You may either install a plug or "hard-wire" the Band Saw directly to a service panel.

If connecting a plug, use a proper UL/CSA listed 2-pole, 3-wire grounding plug suitable for 230V operation.

If the Band Saw is to be hard-wired to a panel, make sure a disconnect is available for the operator. During hard-wiring of the Band Saw, make sure the fuses have been removed or the breakers have been tripped in the circuit to which the Band Saw will be connected. Place a warning placard on the fuse holder or circuit breaker to prevent it being turned on while the machine is being wired.

230 Volt, Three Phase Operation

The **three-phase** model is factory wired for 230 volt, but can be converted to 460 volt if so desired (see "Converting From 230 Volt to 460 Volt"). You may either install a plug or "hard-wire" the Band Saw directly to a service panel.

Recommended Gauges (AWG) of Extension Cords

Amps	Extension Cord Length *					
	25 feet	50 feet	75 feet	100 feet	150 feet	200 feet
< 5	16	16	16	14	12	12
5 to 8	16	16	14	12	10	NR
8 to 12	14	14	12	10	NR	NR
12 to 15	12	12	10	10	NR	NR
15 to 20	10	10	10	NR	NR	NR
21 to 30	10	NR	NR	NR	NR	NR

*based on limiting the line voltage drop to 5V at 150% of the rated amperes.

NR: Not Recommended.

Figure 7

If you are connecting a plug, use a proper UL/CSA listed 3-pole, 4-wire grounding plug suitable for 230 volt operation.

If the Band Saw is to be hard-wired to a panel, make sure a disconnect is available for the operator.

During hard-wiring of the Band Saw, make sure the fuses have been removed or the breakers have been tripped in the circuit to which the Band Saw will be connected. Place a warning placard on the fuse holder or circuit breaker to prevent it being turned on while the machine is being wired.

Converting from 230 Volt to 460 Volt (Three Phase Only)

To convert from 230 volt to 460 volt:

1. Remove the four Phillips head screws on the switch plate (Figure 8) and tilt the switch plate down. Then remove the cover of the switch box.
2. Replace the current contactor with the 460V magnetic contactor (part no. 2013-102D for model 2013; part no. 2415-102D for model 2415; purchased separately).
3. Re-connect the motor leads according to the diagrams inside the motor junction box. These diagrams are also found on pages 56 and 57 of this manual. (*Diagram in motor junction box should take priority.*)
4. Change the lamp input power from 230V to 460V in the panel of the transformer (Figure 9) in accordance with the diagrams on pages 56 and 57.
5. If using a plug, install a proper UL/CSA listed plug suitable for 460V operation.

IMPORTANT: Consult the diagrams on pages 56 and 57 for clarification of any of these changes on 230V to 460V conversion.

Three-Phase Test Run

On the **three-phase** unit, after wiring has been completed, you should check that the wires have been connected properly:

1. Open lower front door of the Band Saw.
2. Connect machine to power source and press the start button, shown in Figure 28, for just an instant, then press the stop button. (See "Operating Controls" on page 21 for further information on the control buttons.)
3. The lower wheel should rotate clockwise as viewed from the front of the machine. If the rotation of the lower wheel is incorrect, **disconnect machine from power.**
4. Switch any two of the three wires at "R,S,T" (see "Electrical Connections", pages 56 and 57) and re-connect machine to power source.

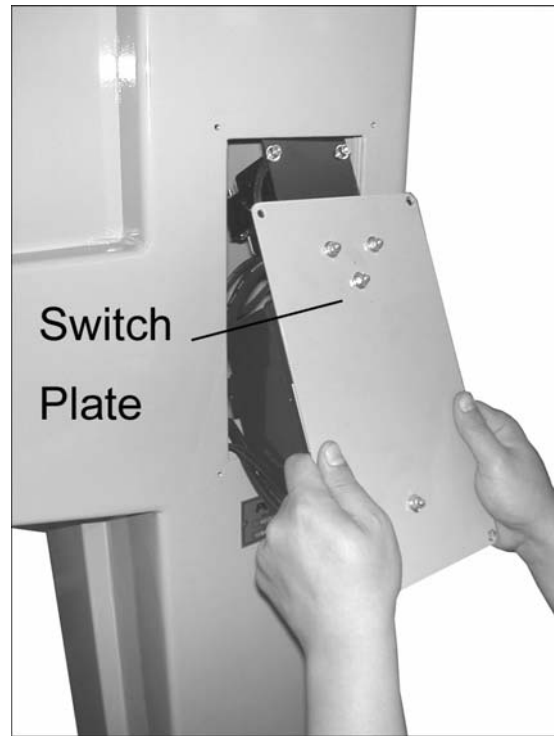

Figure 8

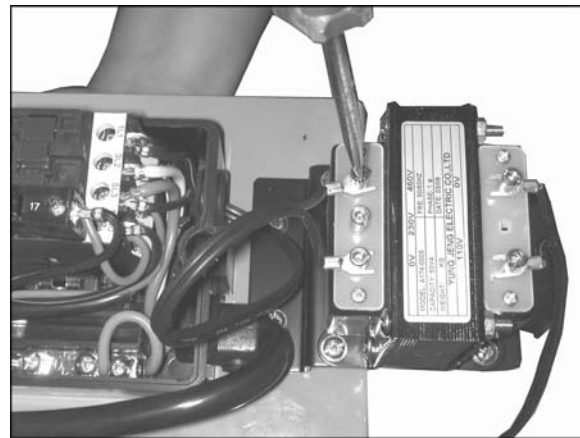

Figure 9

Adjustments

Table Tilt

1. Loosen the lever (Figure 10).
2. Rotate the handwheel (Figure 10) clockwise to tilt table up to 45 degrees to the right, or counterclockwise to tilt the table up to 10 degrees to the left (as viewed from the operator's position).

NOTE: If you tilt the table to the left, you must first remove the stop screw from the machine, shown in Figure 12.

3. Tighten the lever (Figure 10).

NOTE: The lever, shown in Figure 10, can be pivoted so that it doesn't contact the band saw surface. Simply lift straight out on the lever and rotate it on the pin, then release it making sure it seats itself on the pin.

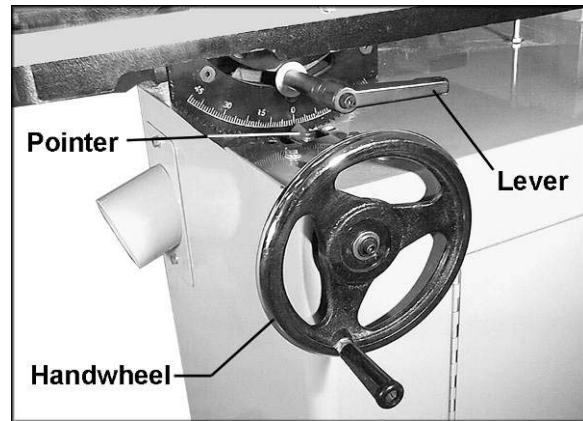

Figure 10

90° Table Stop

The 90° stop, shown in Figure 12, ensures the table will always be perpendicular to the blade after the table is returned to horizontal position.

Check and adjust this 90° stop as follows:

1. Disconnect machine from power source.
2. Loosen lever (Figure 10) and tilt table left until the stop screw rests against the metal platform of the Band Saw, as shown in Figure 12.
3. Place a square on the table and against the blade to check that the table is 90° to the blade. See Figure 11.
4. If table and blade are not square, loosen lock nut (Figure 12) with a 14mm wrench, and turn the head of the stop screw with a 17mm wrench. Turn the screw as needed until there is no longer light showing between the square and the blade.
5. Tighten lock nut (Figure 12) to secure the table stop in position.
6. Tighten the lever (Figure 10).
7. Check that the scale pointer (Figure 10) is at zero. If necessary, loosen the screw on the pointer and shift the pointer to zero. Tighten the screw.

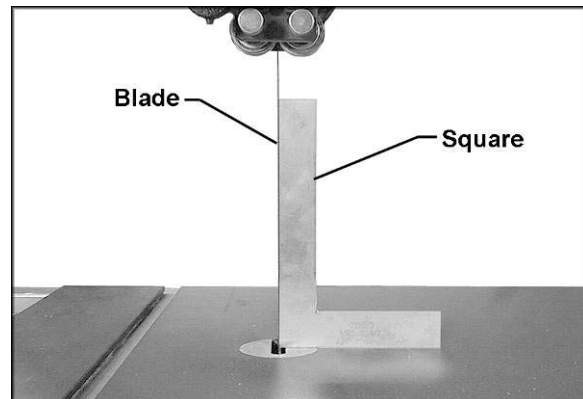

Figure 11

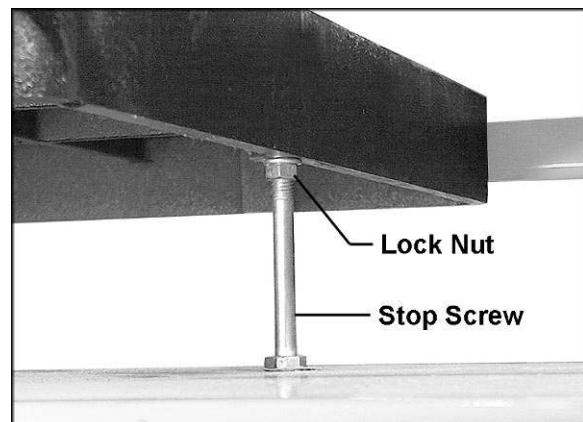

Figure 12

Installing/Changing Blades

CAUTION Always wear gloves when handling blades. New blades are usually packaged in a coiled position; to prevent injury uncoil them slowly and carefully, while wearing gloves and safety glasses.

1. Disconnect machine from power source.
2. Decrease blade tension by rotating blade tension handwheel (A, Figure 14) according to the arrow direction in Figure 14, until the handwheel stops.
3. Remove the table insert (Figure 13).
4. Remove the set screw at the end of the slot (Figure 13) with 4mm (or 5/32") hex wrench.
5. Lower the upper blade guide assembly by loosening the knob (B, Figure 14) and rotating the handwheel (C, Figure 14).
6. Open upper and lower front doors.
7. Carefully remove the blade from between upper and lower blade guides. Remove blade from upper and lower wheels.
8. Guide new blade through table slot. Place blade in upper and lower blade guides. NOTE: Make sure blade teeth point down toward table, and toward the front of the saw.
9. Position blade on the middle of the upper and lower wheels.
10. Replace table insert and set screw.
11. Before operating the band saw, the new blade must be tensioned and tracked properly. Find instructions for tensioning and tracking the blade under "Blade Tension" and "Blade Tracking." The blade guides must also be set properly according to the instructions on pages 18 and 19.

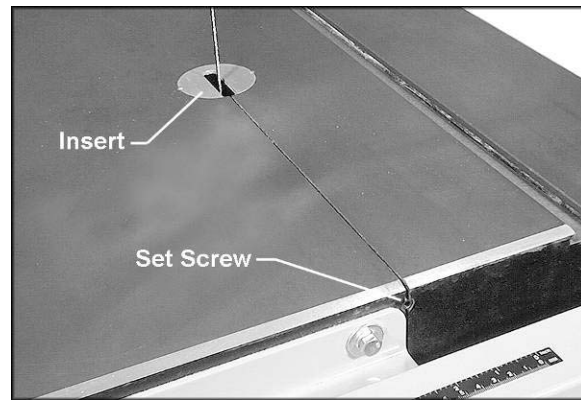

Figure 13

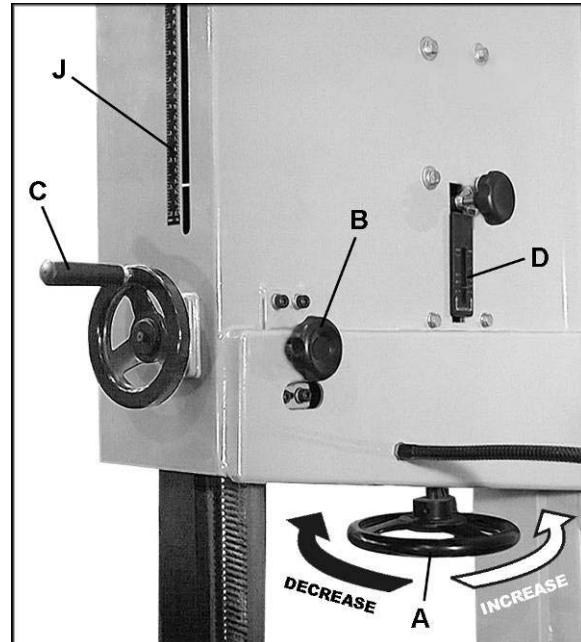

Figure 14

Blade Tension

1. Disconnect machine from power source.
2. Close both upper and lower doors.
3. Rotate blade tension handwheel to set the blade tension, according to the arrow directions in Figure 14.
4. The gauge (D, Figure 14) indicates the approximate tension according to the width of the blade in inches. Initially, set the blade tension to correspond to the width of your blade. As you become familiar with the saw, you may find it necessary to change the blade tension from the initial setting.

Changes in blade width and the type of material being cut will have an effect on blade tension.

Keep in mind that too little or too much blade tension can cause blade breakage and/or poor cutting performance.

TIP: When the band saw is not being used, slightly release the tension on the blade – this will prolong the blade's life. Make a note of the specific tension setting for that particular blade, as shown on the gauge (D, Figure 14). The tension can then be reset quickly when band saw operations are resumed.

Blade Tracking

“Tracking” refers to the position of the saw blade on the wheels while the machine is in operation. Tracking has been factory-adjusted. However, it should be checked occasionally, including after every blade change.

IMPORTANT: Make tracking adjustments with knob (F, Figure 15). DO NOT use screws (G, Figure 15); these were used by the manufacturer for wheel alignment and should NOT be used for blade tracking.

To inspect and adjust tracking, proceed as follows:

1. Disconnect machine from power source.
2. The blade must be properly tensioned *before* adjusting blade tracking. Make sure the blade guides and other parts of the machine will not interfere with the movement of the blade.
3. Open upper front door to expose the upper wheel. Rotate the wheel clockwise by hand, and observe the position of the blade on the wheel. The blade should ride upon the center of the wheel (Figure 16).
4. If the blade tends to move toward the edge of the wheel, loosen wing nut (E, Figure 15) and slightly rotate knob (F, Figure 15). Rotating the knob clockwise will cause the blade to move toward the rear edge of the wheel. Rotating the knob counterclockwise will cause the blade to move toward the front edge of the wheel.

NOTE: This adjustment is sensitive; perform it in small increments and give the blade time to react to the changes, as you continue to rotate the wheel.

5. When the blade is tracking properly in the center of the wheel, re-tighten wing nut (E, Figure 15).
6. Close upper front door.



Figure 15

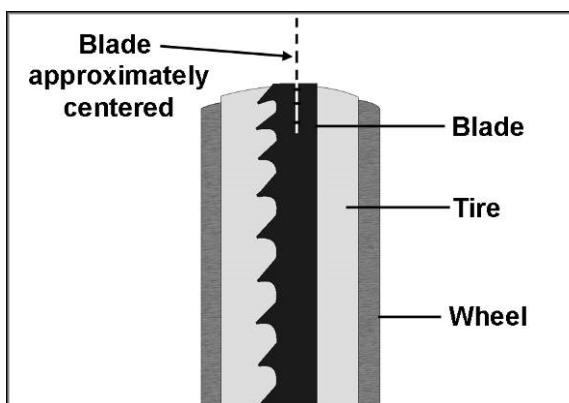

Figure 16

Upper Blade Guide Assembly

1. Disconnect machine from power source.
2. Loosen lock knob (see B, Figure 14) and raise or lower upper blade guide assembly by turning the handwheel (C, Figure 14).
3. Position the blade guide assembly about 3/16" above the material to be cut. The scale (J, Figure 14) shows the distance from bottom of upper blade guides to the table surface.
4. Tighten lock knob (B, Figure 14).

Upper Blade Guides and Upper Support Bearing

To adjust the bearing guides for proper blade control, proceed as follows.

1. Disconnect machine from power source.
2. Blade must already be tensioned and tracking properly.
3. Loosen the locking handle (A, Figure 17).
4. Adjust the guide bracket (B, Figure 17) by rotating knob (G, Figure 17) until the front of the guide bearings (C, Figure 17) are just behind the blade's gullet (curved area at the base of the tooth). See Figure 18.
5. Tighten the locking handle (A, Figure 17).
6. Loosen set screw (D, Figure 17) on the guide bearing assembly, with a 3mm hex wrench. (Figure 17 shows the set screw for the right hand bearing; the set screw for the left hand bearing is shown in Figure 19.)
7. The guide bearing rotates on an eccentric shaft. Adjust the guide bearing, by rotating the knob (H, Figure 19) until the guide bearing rests lightly against the blade. Do not force the guide bearing against the side of the blade.
8. Tighten set screw (D, Figure 17).
9. Repeat the process for the other guide bearing. After adjustment, make sure the set screw (D, Figure 19) is tightened.
10. Loosen nut (E, Figure 19).
11. Adjust the support bearing using the knob (F, Figure 19) until the space between the support bearing and the back edge of the blade is approximately 1/64". A convenient way to achieve this spacing is by placing a dollar bill folded twice (four thicknesses of a dollar bill is approximately 1/64") between blade and support bearing.

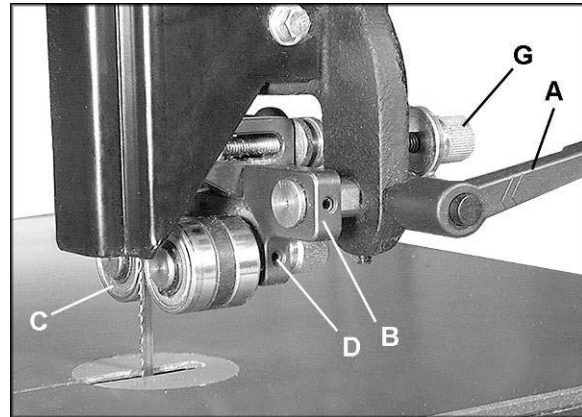

Figure 17

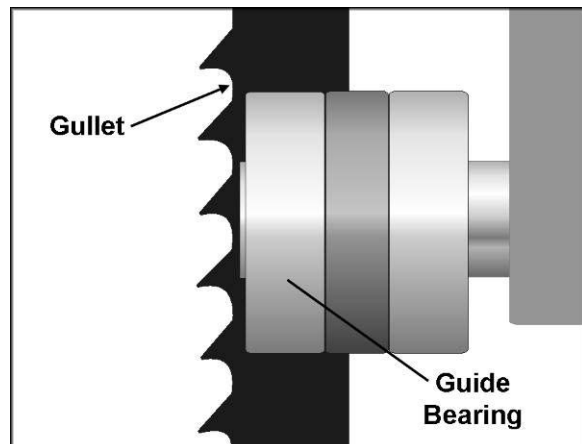

Figure 18

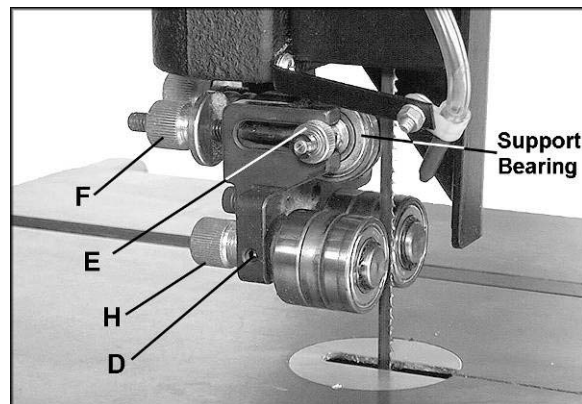

Figure 19

12. Adjust the support bearing until it lightly contacts the dollar bill.
13. When support bearing adjustment is complete, remove dollar bill and tighten nut (E, Figure 19).

Lower Blade Guides and Lower Support Bearing

1. Disconnect machine from power source.
2. Blade must already be tensioned and tracking properly.
3. Loosen two hex cap screws (J, Figure 20).
4. Adjust the guide bracket (K, Figure 20) so that the front of the guide wheels are just behind the blade's gullet (curved area at the base of the tooth).
5. Tighten the two hex cap screws (J, Figure 20).
6. Loosen lock ring (L, Figure 20) on the guide wheel assembly.
7. Rotate the knob (M, Figure 20) until the guide wheel rests lightly against the blade. Do not force the guide wheel against the side of the blade.
8. Tighten the lock ring (L, Figure 20).
9. Repeat this adjustment for the guide wheel on the opposite side.
10. Loosen thumb screw (N, Figure 20).
11. Slide the shaft of the support bearing until the space between the support bearing and the back edge of the blade is approximately 1/64". A convenient way to achieve this spacing is by placing a dollar bill folded twice (four thicknesses of a dollar bill is approximately 1/64") between blade and support bearing.
12. Adjust the support bearing until it lightly contacts the dollar bill.
13. The bearing holder on the shaft is eccentric. Rotate the support bearing until the back edge of the blade overlaps the front face of the support bearing by approximately 1/8". See Figure 21.
14. When adjustments to the support bearing are complete, tighten thumb screw (N, Figure 20).

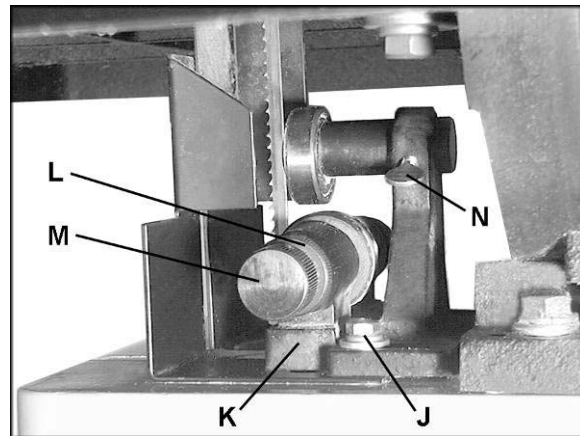

Figure 20

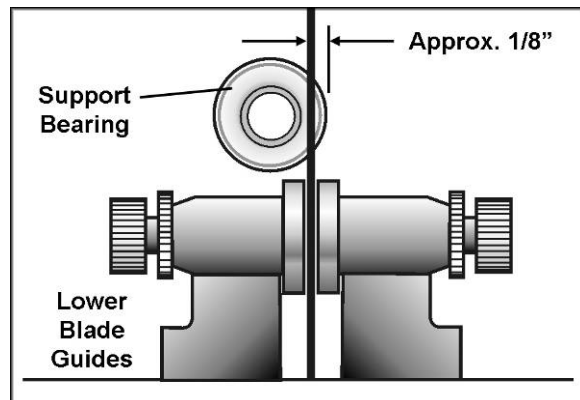

Figure 21

Miter Gauge

A miter gauge is provided for crosscutting operations. Install the miter gauge by sliding the end of the miter gauge bar into the T-slot in the table, as shown in Figure 22.

To adjust the angle of the miter gauge:

1. Loosen the handle (A, Figure 22).
2. Rotate the gauge body until the pointer (B, Figure 22) lines up with the desired angle on the scale. You may have to pivot the stop (C, Figure 22) out of the way to allow the body to rotate.
3. Tighten the handle (A, Figure 22).
4. There are three stops – at 90° and 45° left and right. Each of these can be adjusted by loosening the hex nut (D, Figure 22) and turning the screw (E, Figure 22) as needed. Re-tighten the hex nut (D, Figure 22) when adjustment is finished.
5. Make sure the stop (C, Figure 22) is flipped back into place.

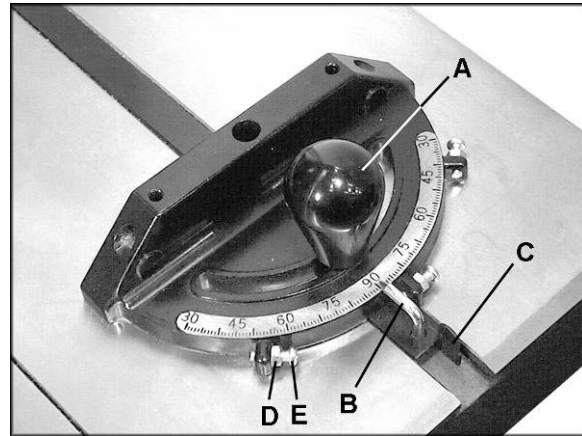

Figure 22

Belt Tension

The drive belt and pulleys are properly adjusted at the factory. However, belt tension should be occasionally checked. The belt will need to be re-tensioned after belt replacement or changing speeds.

1. Disconnect machine from power source.
2. Open the lower back door.
3. Loosen the four hex nuts on the motor plate (A, Figure 23).
4. Turn the tension screw (B, Figure 23) counterclockwise to reduce tension (for example, to remove the belt) or clockwise to increase the tension on the belt.
5. Check the tension by pushing down with moderate pressure against the center of the belt (Figure 24). An adequately tensioned belt will deflect about 1/2".
6. Tighten the hex nut on the tension screw (B, Figure 23) and tighten the four hex nuts (A, Figure 23).

NOTE: A new belt may stretch slightly during the "breaking in" process, and the tension may need to be checked and adjusted occasionally during this period.

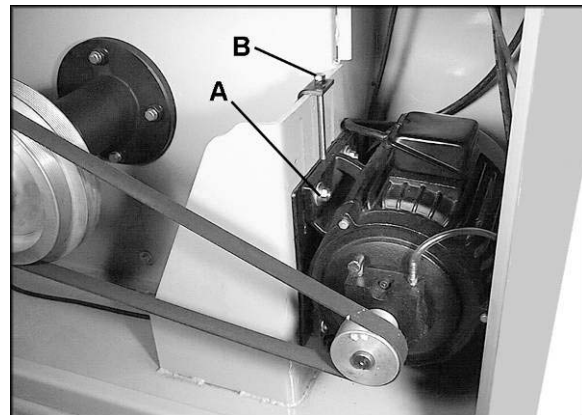

Figure 23

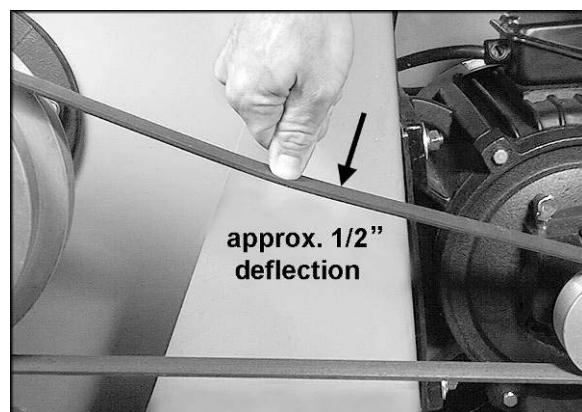

Figure 24

Belt Alignment

If the drive belt is not aligned properly, it can be aligned with one or more of the four set screws located behind the steel plate. Figure 25 shows two of the set screws.

1. Loosen the four hex nuts (A, Figure 23)
2. Rotate clockwise one of the set screws (Figure 25) with a 4mm hex wrench, to push out the motor plate at that point. This will shift slightly the angle of the motor. Use whichever set screw is most effective in adjusting the angle of the motor until the drive belt is aligned.
3. Confirm the alignment of the drive belt by placing a straight edge against the faces of both pulleys, as shown in Figure 26. If the straight edge lies flush against both pulleys, then the pulleys and belt are aligned.
4. Re-tighten the four hex nuts (A, Figure 23).

Blade Speed Adjustment

The bandsaw will operate at 2,000 or 4,000 SFPM (surface feet per minute). Figure 27 shows the appropriate belt position to achieve each speed.

To change the speed:

1. Disconnect machine from power source.
2. Loosen the four hex nuts (A, Figure 23) and rotate the tension screw (B, Figure 23) counterclockwise to release tension on the belt.
3. Slide the belt onto the appropriate set of pulleys (Figure 27). Make sure the belt is aligned properly.
4. Re-tension the belt (see under "Belt Tension") and securely tighten all four hex nuts on the motor plate (A, Figure 23).

Operating Controls

The START (green) and STOP (red) control buttons are mounted to the column (Figure 28).

After the STOP button has been pushed, it remains engaged. Rotate the STOP button clockwise to release it. The Band Saw can now be restarted with the START button.

⚠WARNING After the machine is shut off, allow the wheels and blade to come to a complete stop before opening the doors, making adjustments, or leaving the area.

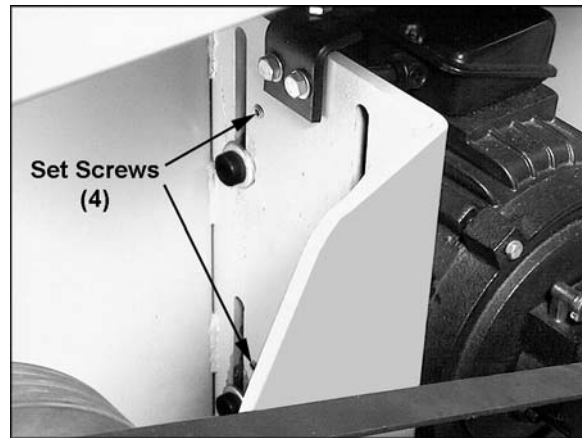

Figure 25

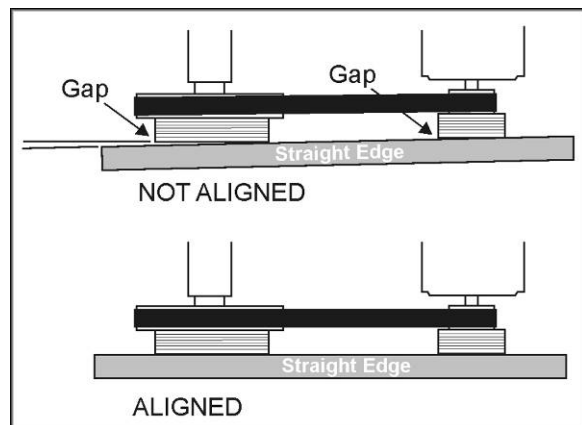

Figure 26

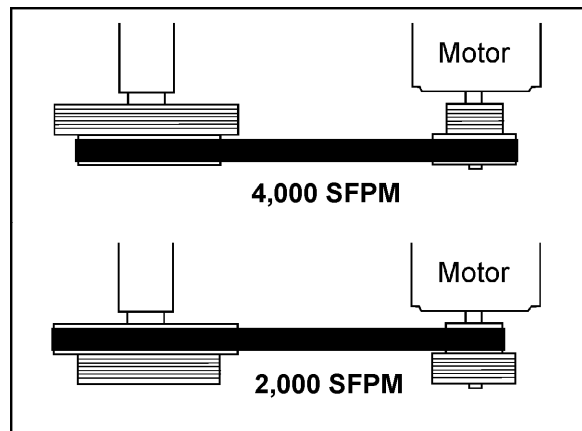

Figure 27

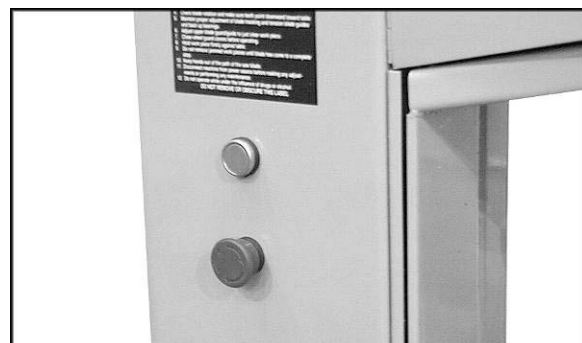

Figure 28

Brake Pedal

An alternate method of stopping the machine is to press the brake pedal, shown in Figure 29. The band saw will shut off when the brake pedal is pressed.

The brake pedal is also useful for stopping the blade quickly, instead of waiting for the blade to coast slowly to a stop after the machine has been shut off.

Re-start the saw by pressing the start button on the column.

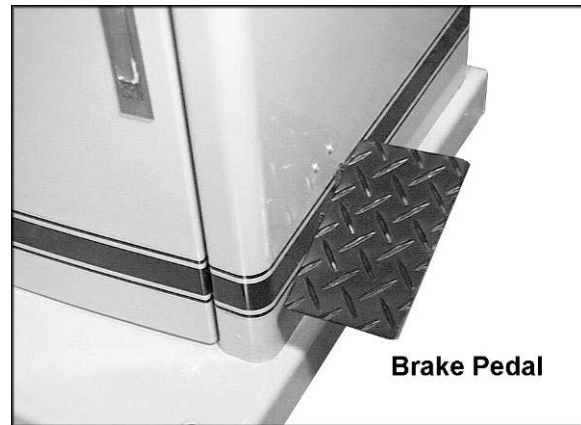

Figure 29

Operation

General Procedure

1. Make sure the blade is adjusted correctly for tension and tracking.
2. Adjust blade guide assembly so that the guide bearings are just above the workpiece (about 3/16") allowing minimum exposure to the blade. See Figure 30.
3. If using the fence, move it into position and lock it to the guide rail. If you are using the miter gauge for a crosscut, the fence should be moved safely out of the way.
4. Turn on the band saw and allow a few seconds for the machine to reach full speed.

⚠WARNING Whenever possible, use a push stick, hold-down, power feeder, jig, or similar device while feeding stock, to prevent your hands getting too close to the blade.

5. Place the straightest edge of the workpiece against the fence, and push the workpiece slowly into the blade. Do not force the workpiece into the blade.

⚠CAUTION When cutting, do not overfeed the blade; overfeeding will reduce blade life, and may cause the blade to break.

6. When cutting long stock, the operator should use roller stands, support tables, or an assistant to help stabilize the workpiece.

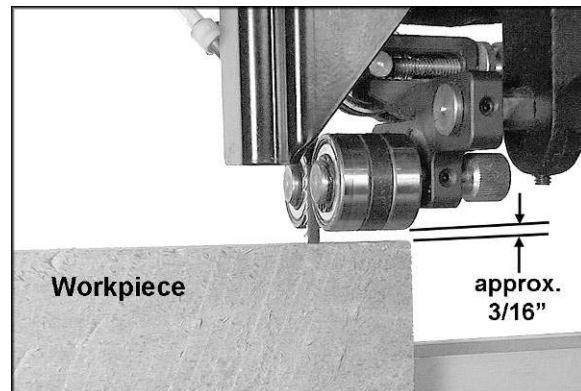

Figure 30

Ripping

Ripping is cutting lengthwise down the workpiece, and with the grain (of wood stock). See Figure 31.

Crosscutting

Crosscutting is cutting across the grain of the workpiece, while using the miter gauge to feed the workpiece into the blade.

Slide the bar of the miter gauge into the end of the slot on the table.

The right hand should hold the workpiece steady against the miter gauge, while the left hand pushes the miter gauge past the blade, as shown in Figure 32.

Do not use the fence in conjunction with the miter gauge. The offcut of the workpiece must not be constrained during or after the cutting process.

CAUTION Using the fence in conjunction with the miter gauge can cause binding and possible damage to the blade.

Resawing

Resawing is the process of slicing stock to reduce its thickness, or to produce boards that are thinner than the original workpiece. Figure 33 demonstrates resawing.

The ideal blade for resawing is the widest one the machine can handle, as the wider the blade the better it can hold a straight line.

When resawing thin stock, use a push block, push stick, or similar device to keep your hands away from the blade.

Blade Lead

Blade drift, or "lead," is a problem that may occur when the blade begins to wander off the cutting line even when the band saw fence is being used. Figure 34 shows an example of blade lead.

Blade lead can be caused by a number of factors, and these should all be checked and corrected if necessary:

- Fence is not parallel to miter slot and blade.
- Blade is not tensioned correctly.
- Blade is dull.
- Teeth have too much "set" on one side of the blade.

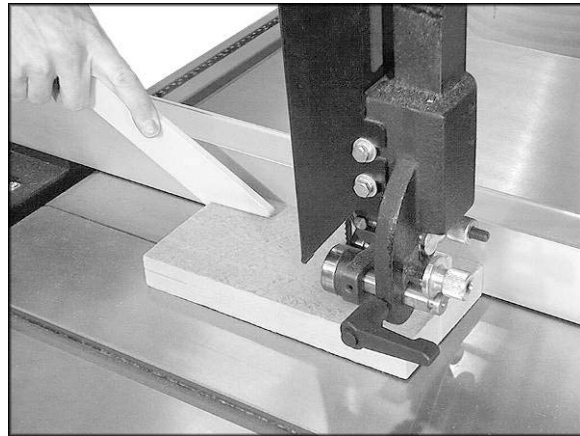

Figure 31
(push stick not included)

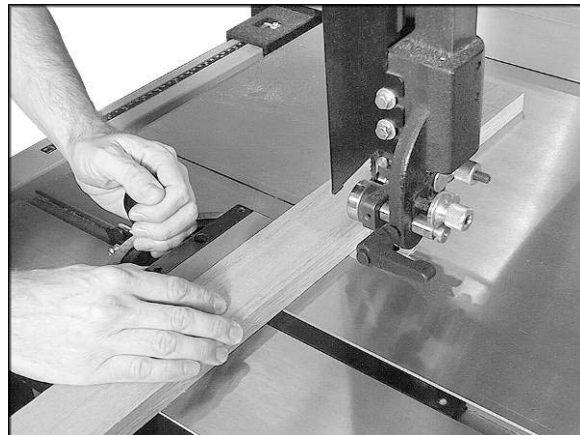

Figure 32

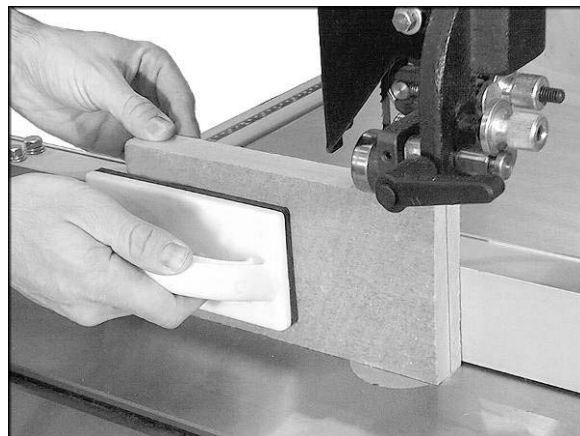

Figure 33
(push block not included)

If replacement of the blade is not currently an option, the blade lead can be compensated for by skewing the fence. Proceed as follows:

1. Cut a scrap piece of wood about the same length as the band saw table, and joint one edge along its length, or rip it on a table saw to give it a straight edge.
2. Draw a line on the board parallel with the jointed, or straight edge of the board.
3. Move the band saw fence out of the way, and carefully make a freehand cut along your drawn line on the board. Stop about midway on the board, and shut off the band saw (allow the blade to come to a complete stop) but do not allow the board to move.
4. Clamp the board to the table.
5. Slide the band saw fence over against the board until it contacts the straight edge of the board at some point. Lock the fence down.
6. Loosen the four hex cap screws at the top of the fence (see Figure 3) and shift the fence until it is parallel to the board along its length.
7. Re-tighten the four hex cap screws.

NOTE: Skewing the fence to correct blade lead is effective for that particular blade; when a new blade is installed, the fence will probably need re-adjustment.

Blade Selection

Using the proper blade for the job will increase the operating efficiency of your band saw, help reduce necessary saw maintenance, and improve your productivity. Thus, it is important to follow certain guidelines when selecting a blade.

Here are factors to consider when selecting a blade:

- The type of material you will be cutting.
- The thickness of the workpiece.
- The features of the workpiece, such as bends or curves with small radii.

These factors are important because they involve basic concepts of saw blade design. There are five (5) blade features that are normally changed to meet certain kinds of sawing requirements. They are:

1. width
2. pitch (number of teeth per inch)
3. tooth form (or shape)
4. the "set" of the teeth
5. the blade material itself

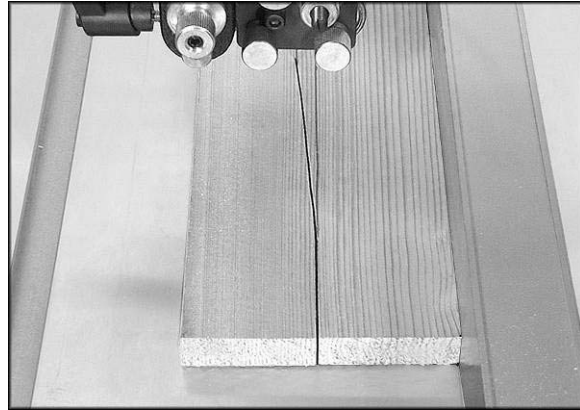

Figure 34

Width

Band saw blades come in different standard widths, measured from the back of the blade to the tip of the tooth. Generally, wider blades are used for ripping or making straight cuts, such as resawing. Narrower blades are often used when the part being cut has curves with small radii. (When cutting straight lines with a narrow blade, the blade may have a tendency to wander, causing "blade lead.")

Pitch

Pitch is measured in "teeth per inch" (T.P.I.) and can be constant or variable. Figure 35 shows blades with different pitches. A fine pitch (more teeth per inch) will cut slower but smoother. A coarse pitch (fewer teeth per inch) will cut rougher but faster.

As a rule of thumb, the thicker the workpiece, the coarser will be the blade pitch. If you have to cut a hard or very brittle material, you will probably want to use a blade with a finer pitch in order to get clean cuts.

Using a blade with too few teeth may cause vibration and a rough cut, while too many teeth may cause the gullets to fill with sawdust and overheat the blade.

As a general rule, use a blade that will have no fewer than 6 and no more than 12 teeth in the workpiece at any given time.

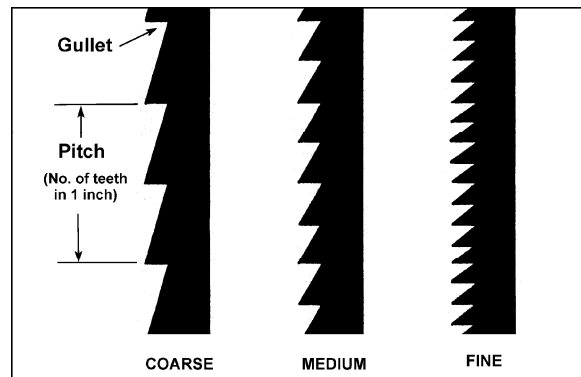

Figure 35

Shape

Figure 36 shows common types of tooth shape. Tooth shape has an effect on cutting rate.

The Regular blade, sometimes called a "raker" blade, has evenly spaced teeth that are the same size as the gullets, and a 0-degree rake angle. These offer precise, clean cuts at slower rates. It is usually a good choice for cutting curves.

The Skip type has fewer teeth and larger gullets, allowing faster cutting rates than the Regular type, with a slightly coarser finish. It is useful for re-sawing and ripping thick stock.

The Hook type blade has larger teeth and gullets and a positive rake angle for more aggressive, faster cutting when re-sawing or ripping thick stock.

Variable-tooth blades combine features of the other styles, and generally produce smooth, quiet cuts.

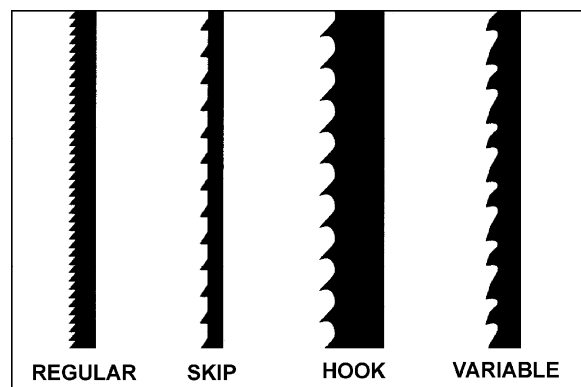

Figure 36

Set

The term "set" refers to the way in which the saw teeth are bent or positioned. Bending the teeth creates a kerf that is wider than the back of the blade.

Set patterns are usually selected depending upon the type of material that needs to be cut. Three common set patterns are shown in Figure 37.

Generally, the Raker set is used for cutting metal workpieces; the Wave set, when the thickness of the workpiece changes, such as cutting hollow tubing or structurals. The Straight set is most often preferred when cutting wood or plastics.

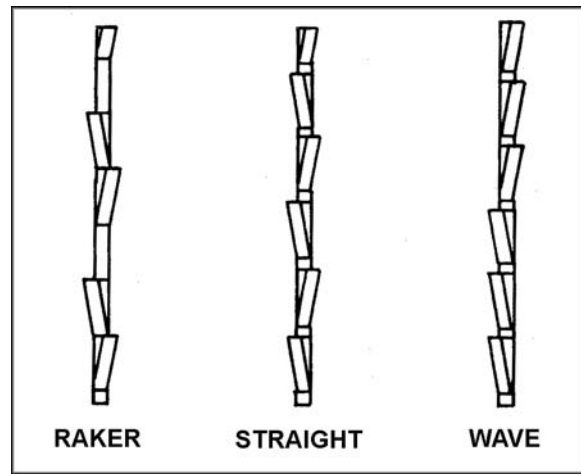

Figure 37

Material

Band saw blades can be made from different types of materials. Some of the most common include spring steel, carbon steel, bimetal (carbon steel equipped with a high speed cobalt steel edge welded to it), or carbide tips.

Because of the importance of blade selection, it is recommended that you use the blade selection guide on page 28.

Blade Breakage

Band saw blades are subject to high stresses and breakage may sometimes be unavoidable. However, many factors can be controlled to help prevent most blade breakage. Here are some common causes for breakage:

1. Misalignment of the blade guides.
2. Feeding workpiece too quickly.
3. Using a wide blade to cut a tight radius curve.
4. Excessive tension.
5. Teeth are dull or improperly set.
6. Upper guides are set too high off the workpiece.
7. Faulty weld on blade.

Maintenance

⚠WARNING Before doing maintenance, disconnect machine from electrical supply by pulling out the plug or switching off the main switch! Failure to comply may cause serious injury.

Clean the band saw regularly to remove any resinous deposits and sawdust. Keep the miter slot in the table free of dust and debris. Keep the guide bearings clean and free of resin.

Grease the rack and pinion system of the guide bar.

Oil any pins, shafts, and joints. Do not get oil on the pulleys or belts.

Bearings on the band saw are sealed for life and do not require lubrication.

Check that the cleaning brush over the lower wheel is working properly; adjust if necessary.

Remove any deposits from the band wheels to avoid vibration and blade breakage.

The table surface must be kept clean and free of rust for best results. If rust appears, use a mixture of household ammonia, a good commercial detergent and 000 steel wool. (Alternatively, commercial rust removers can be found at many hardware stores.) Then wash table down with hot, soapy water, rinse and dry thoroughly.

Apply a light coat of paste wax to the table. Or, some users prefer talcum powder applied with a blackboard eraser rubbed in vigorously once a week; this will fill casting pores and form a moisture barrier. This method provides a table top that is slick and allows rust rings to be easily wiped from the surface. Important also is the fact that talcum powder will not stain wood or mar finishes as wax pickup can.

If the power cord is worn, cut, or damaged in any way, have it replaced immediately.

Tire Replacement

1. Disconnect machine from power source.
2. Remove the blade from the machine.
3. Insert a flat head screwdriver beneath the lip of the tire. Pry up the tire and pull it off the wheel. If this proves difficult, insert a wood wedge or dowel into the opening (see Figure 38), and continue to pry around the perimeter of the wheel until the tire comes off the wheel.

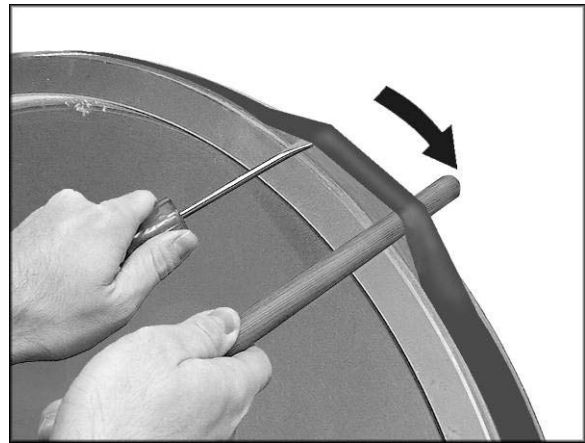

Figure 38

4. Clean the rim of the band wheel before installing the new tire.
5. The new tire can be installed without removing the band wheel from the machine; or, you can remove the band wheel (see "Band Wheel Replacement" for removal instructions) and place it on a workbench, using a home-made jig to secure it while installing the new tire.
6. Place part of the new tire over the band wheel and work it onto the rim of the band wheel. If needed, insert a wood dowel beneath the tire and move the dowel around the perimeter of the band wheel to guide the tire on.

NOTE: Although the tire may *look* too small, it will stretch around the band wheel with the proper exertion, and will form a tight fit. Unlike rubber tires for many older model band saws, the tires for the 2013 and 2415 will not require trimming, equalizing, etc., nor do they require an adhesive. Rather, they are ready to use immediately after installation.

Band Wheel Replacement

⚠WARNING The cast iron band wheels are heavy; use care when removing them.

Disconnect machine from power, and remove the blade. Loosen and remove the hex nut and flat washer at the wheel's hub. Carefully pull off the wheel by hand or with a "wheel puller."

Blade Selection Guide

Identify the material and thickness of your workpiece. The chart will show the recommended PITCH, blade TYPE, and FEED RATE.

Key: H – Hook L – Low
 S – Skip M – Medium
 R – Regular H – High

Example: 10/H/M means 10 teeth per inch / Hook Type Blade / Medium Feed

MATERIAL/S		WORKPIECE THICKNESS			
		1/2"	1"	3"	6+"
WOODS	HARDWOOD	10/R/L	8/R/L	3/H/M	3/H/M
	SOFTWOOD	10/R/L	8/R/L	3/H/M	3/H/M
NON-METALS	CARBON	10/R/L	6/R/L	3/S/M	3/S/M
	MICA	32/R/L	—	—	—
	ASBESTOS	8/R/L	6/R/L	3/S/M	3/S/M
	HARD RUBBER	10/R/L	8/R/L	6/R/M	2/S/H
PLASTICS	FORMICA	14/R/M	10/R/M	4/H/H	4/H/H
	MASONITE	10/R/L	4/S/L	3/S/M	3/H/M
	MICARTA	14/R/M	10/R/M	4/H/H	3/H/H
	PLEXIGLAS	10/R/L	6/R/L	3/S/M	3/S/M
	PAPER	14/R/L	10/R/L	4/S/L	3/S/M

For Radius Cutting

Study the part drawing or prototype, or actually measure the smallest cutting radius required, and locate this radius (in inches) on the chart at the right. Follow the curve to where the approximate blade width is specified. If a radius falls between two of the curves, select the widest blade that will saw this radius.

This procedure should be used for making initial blade selections. These recommendations can, of course, be adjusted to meet specific requirements of a cutting job. Compromises may be necessary if you cannot find all needed specifications in a single blade.

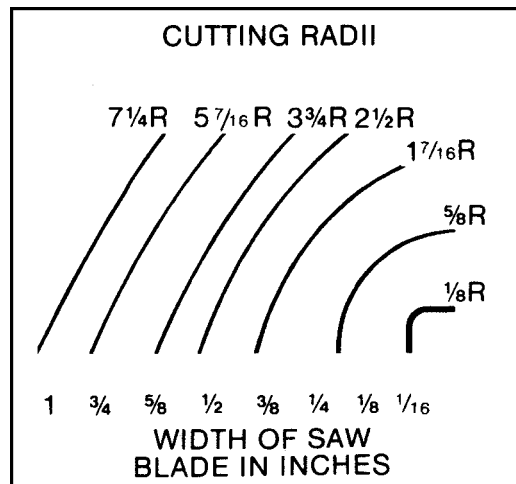

Troubleshooting – Operational Problems

Trouble	Probable Cause	Remedy
Table tilt does not hold position under load.	Locking lever is not tight.	Tighten locking lever (see page 15).
	Trunnion locking mechanism is broken or worn.	Replace trunnion locking mechanism.
Table will not tilt.	Trunnion is not lubricated.	Lubricate trunnion.
	Trunnion is jammed.	Disassemble and replace jammed parts.
Table vibration while sawing.	Incorrect blade speed.	Position belt for correct speed (see page 21). Also use acceptable feed rate for the material being worked (page 28).
	Drive belt is too slack.	Increase tension on drive belt. (see page 20). Replace belt if worn.
	Incorrect choice of saw blade pitch.	Check blade selection chart and use correct blade (see page 28).
	Saw dust or debris on band wheel. Or tire is worn/damaged.	Keep band wheels clean. Replace tires if necessary.
	Support bearing(s) are worn.	Replace support bearings.
Surface finish on workpiece is rough.	Saw blade speed is too low.	Increase speed.
	Saw blade pitch is too coarse.	Change to finer pitch blade.
Saw blade cutting inaccurately. Cuts are not straight.	Worn blade teeth or damaged blade.	Replace blade.
	Fence not parallel to blade.	Align fence properly (see page 11).
	Incorrect adjustment of blade guides.	Adjust blade guides properly (see pages 18 and 19).
	Incorrect blade speed used.	Change to correct speed (see page 21).
	Workpiece being fed too strongly.	Reduce feed force.
	Upper blade guides not located close enough to workpiece.	Guides should be about 3/16" above workpiece (see page 22).
	Incorrect choice of saw blade for that particular cutting operation.	Change to correct blade.
	Blade tension too light.	Increase tension (see page 16).
Blade cannot be tensioned properly.	Tension springs are fatigued.	Replace tension springs (contact service representative).
Blade forms cracks at base of teeth. Blade forms cracks at base of teeth. (continued)	Teeth not suitable for particular job, or are incorrectly set.	Replace with proper blade for job.
	Blade thickness not suitable for band wheel diameter.	Replace with proper thickness blade.
	Blade sharpened incorrectly, becomes overheated.	Sharpen blade properly or replace.
	Band wheels have become misaligned.	Contact service representative.

Trouble	Probable Cause	Remedy
Cracks on back edge of blade.	Workpiece being fed too quickly.	Reduce feed speed to lessen strain on the blade.
	Welding on blade not perfectly aligned.	Eliminate the welded part, and re-weld properly; or acquire a new blade.
	Support bearing is worn; caused by constant contact with back of blade.	Replace support bearing. Adjust new bearing according to instructions (see pages 18 and 19).
Blade breaks prematurely.	Feed force too great.	Reduce feed force.
	Blade pitch too coarse.	Refer to blade selection chart; use finer pitch blade (see page 28).
	Support bearing not properly supporting blade.	Check support bearing for correct position and signs of wear. Adjust or replace as needed.
	Blade tensioned too tightly.	Reduce tension (see page 16).
Blade breaks close to weld.	Blade overheated during welding.	Have blade annealed, or eliminate brittle part and weld correctly.
	Blade cooled too rapidly after welding.	Have blade annealed, or eliminate brittle part and weld correctly.
Premature dulling of saw teeth.	Blade "pitch" too fine.	Refer to blade selection chart (page 28). Use blade with coarser pitch.
	Feed pressure too light.	Increase feed pressure.
	Cutting rate too low.	Increase feed pressure and cutting rate.
	Incorrect choice of blade.	Re-examine material. Select proper blade from the chart (page 28).
	Chipped tooth or foreign object lodged in cut.	Stop the saw and remove lodged particle. Replace blade if damaged.
Blade binds in the workpiece.	Incorrect blade tension or damaged blade.	Correct accordingly.
	Blade too wide for desired radius.	Select narrower blade. See chart on page 28.

Troubleshooting – Mechanical and Electrical Problems

Trouble	Probable Cause	Remedy
Machine will not start/restart or repeatedly trips circuit breaker or blows fuses.	No incoming power.	Verify machine is connected to power source. Make sure START button is pushed in completely, and the STOP button is disengaged. See page 21.
	Cord damaged.	Replace cord.
	Overload automatic reset has not been reset.	Remove the switch plate from the rear of the column (see page 14) and reset the overload by pushing in completely the OFF (red) button on the magnetic switch. If problem persists, check amp setting on the motor starter.
	Band Saw frequently trips.	One cause of overloading trips which are not electrical in nature is too heavy a cut. The solution is to reduce feed pressure into the blade. If too heavy a cut is not the problem, then check the amp setting on the overload relay. Match the full load amps on the motor as noted on the motor plate. If amp setting is correct then there is probably a loose electrical lead. Check amp setting on motor starter.
	Building circuit breaker trips or fuse blows.	Verify that band saw is on a circuit of correct size. If circuit size is correct, there is probably a loose electrical lead. Check amp setting on motor starter.
	Switch or motor failure (how to distinguish).	If you have access to a voltmeter, you can separate a starter failure from a motor failure by first, verifying incoming voltage at 220+/-20 and second, checking the voltage between starter and motor at 220+/-20. If incoming voltage is incorrect, you have a power supply problem. If voltage between starter and motor is incorrect, you have a starter problem. If voltage between starter and motor is correct, you have a motor problem.
	Motor overheated.	Clean motor of dust or debris to allow proper air circulation. Allow motor to cool down before restarting.
	Motor failure.	If electric motor is suspect, you have two options: Have a qualified electrician test the motor for function or remove the motor and take it to a qualified electric motor repair shop and have it tested.
	Miswiring of the unit.	Double check to confirm all electrical connections are correct. Refer to appropriate wiring diagrams on pages 54 through 57 to make any needed corrections.

Trouble	Probable Cause	Remedy
Machine will not start/restart or repeatedly trips circuit breaker or blows fuses.	Switch failure.	If the start/stop switch is suspect, you have two options: Have a qualified electrician test the switch for function, or purchase a new start/stop switch and establish if that was the problem on changeout.
Band Saw does not come up to speed.	Extension cord too light or too long.	Replace with adequate size and length cord.
	Low current.	Contact a qualified electrician.

Replacement Parts

Replacement parts are listed on the following pages. To order parts or reach our service department, call 1-800-274-6848, Monday through Friday (see our website for business hours, www.powermatic.com). Having the Model Number and Serial Number of your machine available when you call will allow us to serve you quickly and accurately.

Parts List: Saw Body Assembly (2013 Band Saw)

Index No.	Part No.	Description	Size	Qty
1	2013-101A	Body		1
2	2013-102N	Magnetic Switch	1PH, 230V	1
	2013-102CSN	Contact Switch for 1 Phase (not shown)		1
	2013-102ORN	Overload Relay for 1 Phase (not shown)		1
	2013-102C	Magnetic Switch	3PH, 230V	1
	2013-102CCS	Contact Switch for 230V 3 Phase (not shown)		1
	2013-102COR	Overload Relay for 230V 3 Phase (not shown)		1
	2013-102D	Magnetic Switch	3PH, 460V	1
	2013-102DCS	Contact Switch for 460V 3 Phase (not shown)		1
	2013-102DOR	Overload Relay for 460 3 Phase (not shown)		1
3	2013-103B	Switch Plate		1
4	TS-069204	Flat Washer	#10	10
5	TS-0720051	Lock Washer	#10	8
6	TS-0560071	Hex Nut	#10-24	2
7	TS-081C022	Phillips Pan Head Machine Screw	#10-24x3/8"	6
8	TS-081C052	Phillips Pan Head Machine Screw	#10-24x3/4"	2
9	6295121	Dust Chute		1
10	TS-0680031	Flat Washer	5/16"	2
11	TS-0051051	Hex Cap Screw	5/16"-18x1"	2
12	TS-0560071	Hex Nut	#10-24	2
13	TS-0561021	Hex Nut	5/16"-18	2
14	6295126	Brush		1
15	TS-081C082	Phillips Pan Head Machine Screw	#10-24x1-1/2"	2
16	6295128	Lower Back Door		1
17	TS-0680021	Flat Washer	1/4"	9
18	TS-1503031	Socket Head Cap Screw	M6-1.0Px12	9
19	6295131	Power Cord	1PH	1
	2013-119A	Power Cord (3Ph)	ST 14AWG 600V	1
20	6295132	Lower Blade Wheel		2
21	JWBS20-21	Tire		2
22	6295134	Hex Nut	3/4"-16(L.H.)	2
23	TS-0680091	Flat Washer	3/4"	2
24	6295054	Blade	1"x.026x3 hook	1
25	6295137	Door Latch		3
26	6295138	Door Catch		3
27	6295139	Phillips Pan Head Machine Screw	M4x4	9
28	2013-128	Lower Front Door		1
29	2013-129	Upper Front Door		1
30	6295142	Stop Button		1
31	6295143	Start Button		1
32	6295144	Scale		1
33	6295145	I.D Label	2HP	1
33	6295145A	I.D Label	3HP	1
34	6295146	Warning Label		1
35	6295147	Name Plate		1
37	TS-0720081	Lock Washer	5/16"	1
38	2013-138	Upper Blade Wheel		1
39	6295208	Ball Bearing	6205	2
40	2013-140	Retaining Ring	Ø 52	2
41	2013-141	Transformer (not shown)		1
42	2013-142A	Strain Relief	3PH, PG21	2
43	2013-143	Control Cord, 1PH (not shown)		2
	2013-143A	Control Cord, 3PH (not shown)	ST, 18AWG 600V	2
44	2013-144	Switch Clamp	3PH, PG16	1
45	2013-145	Strain Relief	1PH, PG21-14	1
	2013-142A	Strain Relief	3PH, PG21-18	1

Parts List: Saw Body Assembly (2415 Band Saw)

Index No.	Part No.	Description	Size	Qty
1	2415-101A	Body		1
2	2415-102N	Magnetic Switch	1PH, 230V	1
	2415-102CSN	Contact Switch for 1 Phase (not shown)		1
	2415-102ORN	Overload Relay for 1 Phase (not shown)		1
	2415-102C	Magnetic Switch	3PH, 230V	1
	2415-102CCS	Contact Switch for 230V 3 Phase (not shown)		1
	2415-102COR	Overload Relay for 230V 3 Phase (not shown)		1
	2415-102D	Magnetic Switch	3PH, 460V	1
	2415-102DCS	Contact Switch for 460V 3 Phase (not shown)		1
	2415-102DOR	Overload Relay for 460V 3 Phase (not shown)		1
3	2013-103B	Switch Plate		1
4	TS-069204	Flat Washer	#10	10
5	TS-0720051	Lock Washer	#10	8
6	TS-0560071	Hex Nut	#10-24	2
7	TS-081C022	Phillips Pan Head Machine Screw	#10-24x3/8"	6
8	TS-081C052	Phillips Pan Head Machine Screw	#10-24x3/4"	2
9	6295121	Dust Chute		1
10	TS-0680031	Flat Washer	5/16"	2
11	TS-0051051	Hex Cap Screw	5/16"-18x1"	2
12	TS-0560071	Hex Nut	#10-24	2
13	TS-0561021	Hex Nut	5/16"-18	2
14	6295126	Brush		1
15	TS-081C082	Phillips Pan Head Machine Screw	#10-24x1-1/2"	2
16	6294804	Lower Back Door		1
17	TS-0680021	Flat Washer	1/4"	9
18	TS-1503031	Socket Head Cap Screw	M6-1.0Px12	9
19	6295131	Power Cord	1PH	1
	2415-119A	Power Cord (3PH)	ST 12AWG 600V	1
20	6294806	Lower Blade Wheel		2
21	6294807	Tire		2
22	6295134	Hex Nut	3/4"-16(L.H.)	2
23	TS-0680091	Flat Washer	3/4"	2
24	6295061	Blade	1"x.026x3 hook	1
25	6295137	Door Latch		3
26	6295138	Door Catch		3
27	6295139	Phillips Pan Head Machine Screw	M4x4	9
28	2415-128	Lower Front Door		1
29	2415-129	Upper Front Door		1
30	6295142	Stop Button		1
31	6295143	Start Button		1
32	6294810	Scale		1
33	6294811	I.D Label	3HP	1
33	6294811A	I.D Label	5HP	1
34	6295146	Warning Label		1
35	6295147	Name Plate		1
37	TS-0720081	Lock Washer	5/16"	1
38	2415-138	Upper Blade Wheel		1
39	6295208	Ball Bearing	6205	2
40	2013-140	Retaining Ring	Ø 52	2
41	2013-141	Transformer (not shown)		1
42	2013-142A	Strain Relief	3PH, PG21	2
43	2013-143	Control Cord, 1PH (not shown)		2
	2013-143A	Control Cord, 3PH (not shown)	ST, 18AWG 600V,	2
44	2013-144	Switch Clamp	3PH, PG16	1
45	2013-145	Strain Relief	1PH, PG21-14	1
	2013-142A	Strain Relief	3PH, PG21-18	1

Parts List: Table Assembly (2013 Band Saw)

Index No.	Part No.	Description	Size	Qty
1	2013-201	Carriage Bolt	1/2"-12x9"	1
2	6295149	Trunnion (Left Side)		1
3	2013-203	Table Bracket		1
4	TS-0680041	Flat Washer	3/8"	8
5	TS-0720091	Lock Washer	3/8"	8
6	TS-0060061	Hex Cap Screw	3/8"-16x1-1/4"	8
7	6295154	Name Plate		1
8	6295155	Pointer		1
9	TS-0720051	Lock Washer	#10	1
10	TS-081C022	Phillips Pan Head Machine Screw	#10-24x3/8"	1
11	6295158	Locking Handle		1
12	TS-0680061	Flat Washer	1/2"	1
13	2013-213	Angle Scale Plate		1
	6295328	Miter Gauge Assembly (Items 14 thru 24, 86)		1
14	6295161	Pin		1
15	6295162	Flat Head Screw	1/4"	1
16	6295163	Guard Disc		1
17	TS-1533062	Phillips Pan Head Machine Screw	M5-0.8Px20	3
18	TS-1540031	Nut	M5	3
19	6295166	Knob		1
20	6295167	Miter Gauge Body		1
21	6295168	Pin		1
22	6295169	Pointer		1
23	TS-1521011	Socket Set Screw	M4x4	1
24	6295171	Stop Block		1
25	6295172	Work Table		1
26	TS-0050021	Hex Cap Screw	1/4"-20x5/8"	9
	6295329	Fence Assembly (Items 7,27,28,32,33,34,39 thru 52)		1
27	TS-0720071	Lock Washer	1/4"	10
28	TS-0680021	Flat Washer	1/4"	10
29	6295176	Rear Rail		1
30	6295177	Table Insert		1
31	6295178	Spring Pin	Ø3x10	2
32	TS-0561011	Hex Nut	1/4"-20	2
33	6295180	Rear Hook		1
34	6295181	Sliding Pad		1
35	TS-0570031	Hex Nut	3/8"-16	1
36	TS-0060171	Hex Cap Screw	3/8"-16x4"	1
37	6295184	Scale		1
38	6295185	Guide Rail		1
39	6295186	Fence		1
40	TS-0081031	Hex Cap Screw	5/16"-18x3/4"	4
41	TS-0720081	Lock Washer	5/16"	4
42	TS-0680031	Flat Washer	5/16"	4
43	TS-0810012	Screw	#10-24x1/4"	1
44	TS-0733031	External Tooth Lock Washer	#10	1
45	6295193	Pointer		1
46	6295194	Fence Body		1
47	6295195	Knob		1
48	6295196	Lock Handle		1
49	6295197	Lock Plate		1
50	6295198	Pad		2
51	6295199	Pin		1
52	6295200	Pin		1
53	2013-253	Bushing		1
54	TS-0051061	Hex Cap Screw	5/16"-18x1-1/4"	2
56	TS-0270051	Socket Set Screw	5/16"-18x1/2"	1
57	TS-0270061	Socket Set Screw	5/16"-18x5/8"	4
58	6294841	Front Rail		1
59	2013-259	Trunnion (Right Side)		1

Index No.	Part No.	Description	Size	Qty
60	2013-260	Shaft		1
61	2013-261	C-Ring	S-17	1
62	2013-262	Gear		1
63	2013-263	Worm Gear		1
64	TS-081F032	Phillips Pan Head Machine Screw	1/4"-20X1/2"	2
65	2013-265	Worm Gear Cap		1
66	BB-6002	Ball Bearing	6002	1
67	2013-267	C-Ring	S-15	1
68	2013-268	Worm Shaft		1
69	TS-0270051	Socket Set Screw	5/16"-18X1/2"	2
70	2013-270	Bevel Gear		2
71	2013-271	Bushing		1
72	TS-0267021	Socket Set Screw	1/4"-20x1/4"	6
73	2013-273	Key	5x5x12	1
74	2013-274	C-Ring	S-13	1
75	2012-275	Bushing		2
76	2013-276	Handwheel Assembly		1
77	2013-277	Shaft		1
78	TS-0246031	Flat Head Socket Screw	5/16"-18x3/4"	6
79	TS-0255031	Button Head Socket Screw	5/16"-18x5/8"	4
80	TS-0720081	Lock Washer	5/16"	4
81	TS-0680031	Flat Washer	5/16"	4
82	2013-282	Gear Bracket		1
83	2013-283	Handle		1
84	2013-284	Key	3x3x8	2
85	2013-285	End Cover		2
86	2013-286	Guide Bar		1

Parts List: Table Assembly (2415 Band Saw)

Index No.	Part No.	Description	Size	Qty
1	2013-201	Carriage Bolt	1/2-12x9"	1
2	6295149	Trunnion (Left Side)		1
3	2013-203	Table Bracket		1
4	TS-0680041	Flat Washer	3/8"	8
5	TS-0720091	Lock Washer	3/8"	8
6	TS-0060061	Hex Cap Screw	3/8"-16x1-1/4"	8
7	6295154	Name Plate		1
8	6295155	Pointer		1
9	TS-0720051	Lock Washer	#10	1
10	TS-081C022	Phillips Pan Head Machine Screw	#10-24x3/8"	1
11	6295158	Locking Handle		1
12	TS-0680061	Flat Washer	1/2"	1
13	2013-213	Angle Scale Plate		1
	6295328	Miter Gauge Assembly (Items 14 thru 24, 86)		1
14	6295161	Pin		1
15	6295162	Flat Head Screw	1/4"	1
16	6295163	Guard Disc		1
17	TS-1533062	Phillips Pan Head Machine Screw	M5x20	3
18	TS-1540031	Nut	M5	3
19	6295166	Knob		1
20	6295167	Miter Gauge Body		1
21	6295168	Pin		1
22	6295169	Pointer		1
23	TS-1521011	Socket Set Screw	M4x4	1
24	6295171	Stop Block		1
25	6294836	Work Table		1
26	TS-0050021	Hex Cap Screw	1/4"-20x5/8"	9
	6294842	Fence Assembly (Items 7, 27, 28, 32, 33, 34, 39 thru 52)		1
27	TS-0720071	Lock Washer	1/4"	10
28	TS-0680021	Flat Washer	1/4"	10
29	6294837	Rear Rail		1
30	6295177	Table Insert		1
31	6295178	Spring Pin	Ø3x10	2
32	TS-0561011	Hex Nut	1/4"-20	2
33	6295180	Rear Hook		1
34	6295181	Sliding Pad		1
35	TS-0570031	Hex Nut	3/8"-16	1
36	TS-0060171	Hex Cap Screw	3/8"-16x4"	1
37	6294838	Scale		1
38	6294839	Guide Rail		1
39	6294840	Fence		1
40	TS-0081031	Hex Cap Screw	5/16"-18x3/4"	4
41	TS-0720081	Lock Washer	5/16"	4
42	TS-0680031	Flat Washer	5/16"	4
43	TS-0810012	Screw	#10-24x1/4"	1
44	TS-0733031	External Tooth Lock Washer	#10	1
45	6295193	Pointer		1
46	6295194	Fence Body		1
47	6295195	Knob		1
48	6295196	Lock Handle		1
49	6295197	Lock Plate		1
50	6295198	Pad		2
51	6295199	Pin		1
52	6295200	Pin		1
53	2013-253	Bushing		1
54	TS-0051061	Hex Cap Screw	5/16"-18x1-1/4"	2
56	TS-0270051	Socket Set Screw	5/16"-18x1/2"	1
57	TS-0270061	Socket Set Screw	5/16"-18x5/8"	4
58	6294841	Front Rail		1
59	2013-259	Trunnion (Right Side)		1

Index No.	Part No.	Description	Size	Qty
60	2013-260	Shaft		1
61	2013-261	C-Ring	S-17	1
62	2013-262	Gear		1
63	2013-263	Worm Gear		1
64	TS-081F032	Phillips Pan Head Machine Screw	1/4"-20X1/2"	2
65	2013-265	Worm Gear Cap		1
66	BB-6002	Ball Bearing	6002	1
67	2013-267	C-Ring	S-15	1
68	2013-268	Worm Shaft		1
69	TS-0270051	Socket Set Screw	5/16"-18X1/2"	2
70	2013-270	Bevel Gear		2
71	2013-271	Bushing		1
72	TS-0267021	Socket Set Screw	1/4"-20x1/4"	6
73	2013-273	Key	5x5x12	1
74	2013-274	C-Ring	S-13	1
75	2012-275	Bushing		2
76	2013-276	Handwheel Assembly		1
77	2013-277	Shaft		1
78	TS-0246031	Flat Head Socket Screw	5/16"-18x3/4"	6
79	TS-0255031	Button Head Socket Screw	5/16"-18x5/8"	4
80	TS-0720081	Lock Washer	5/16"	4
81	TS-0680031	Flat Washer	5/16"	4
82	2013-282	Gear Bracket		1
83	2013-283	Handle		1
84	2013-284	Key	3x3x8	2
85	2013-285	End Cover		2
86	2013-286	Guide Bar		1

Table Assembly (2013 and 2415)

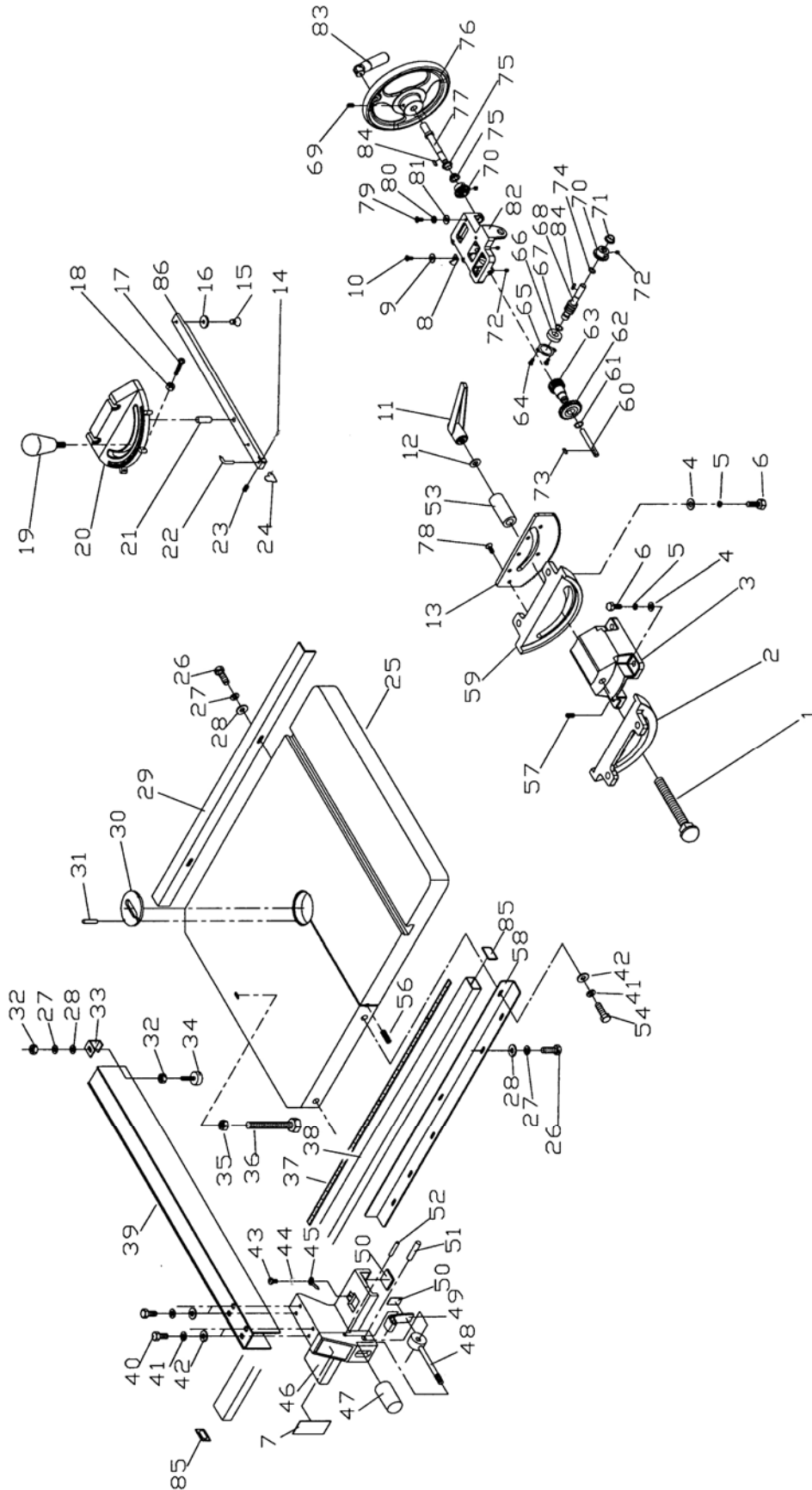

Parts List: Upper Wheel Base Assembly (2013 Band Saw)

Index No.	Part No.	Description	Size	Qty
1	2013-301	Upper Wheel Shaft <i>(for 2013, serial #05032013437 and higher)</i>		1
	6295889	Upper Wheel Shaft <i>(for 2013-1, serial #01062013080 to 05032013437)</i> <i>(for 2013-3, serial #01062013090 to 05032013437)</i>		1
2	TS-0680091	Flat Washer	3/4"	1
4	TS-0720091	Lock Washer	3/8"	8
5	2013-305	Upper Wheel Shaft Bracket		1
6	6295890	Lock Nut	3/4"-16 UNF	1
7	TS-0270051	Socket Set Screw	5/16"-18x1/2"	5
8	6295213	C-Ring	S-20	2
9	6295214	Lever Shaft		1
10	6295215	Upper Adjustment Bracket		1
11	6295891	Upper Wheel Guide Bracket		1
12	6295217	Adjustment Bracket		1
13	TS-0640091	Nylon Lock Hex Nut	3/8"-16	1
14	6295219	Lock Knob		1
15	6295220	Adjustment Screw		1
16	6295221	Elevator Bracket		1
17	6295222	Spring		2
18	6295223	Guide Bar		2
19	TS-0810012	Screw	#10-24x1/4"	1
20	6295225	Bracket		1
21	6295226	Pointer		1
22	TS-0720051	Lock Washer	#10	3
23	6295227	Upper Wheel Bracket Base		1
24	6295228	Bracket Shaft		2
25	6295229	Handwheel		1
26	TS-0720081	Lock Washer	5/16"	2
27	TS-0640081	Nylon Insert Lock Nut	5/16"-18	2
28	TS-0208121	Socket Head Cap Screw	5/16"-18 x 2-1/2"	2
29	TS-0680041	Flat Washer	3/8"	4
30	TS-0060081	Hex Cap Screw	3/8"-16x1-3/4"	6
31	2013-331	Work Lamp	115V	1
32	6295236	Scale (Blade tension)		1
33	2013-333	Bushing		3
34	TS-081C022	Phillips Pan Head Machine Screw	#10-24x3/8"	2

Parts List: Upper Wheel Base Assembly (2415 Band Saw)

Index No.	Part No.	Description	Size	Qty
1	2013-301	Upper Wheel Shaft (for 2415, serial #05022415369 and higher)		1
	6295889	Upper Wheel Shaft (for 2415-1, serial #01062415017 to 05022415368) (for 2415-3, serial #01062415011 to 05022415368)		1
2	TS-0680091	Flat Washer	3/4"	1
4	TS-0720091	Lock Washer	3/8"	8
5	2013-305	Upper Wheel Shaft Bracket		1
6	6295890	Lock Nut	3/4"-16 UNF	1
7	TS-0270051	Socket Set Screw	5/16"-18x1/2"	5
8	6295213	C-Ring	S-20	2
9	6295214	Lever Shaft		1
10	6295215	Upper Adjustment Bracket		1
11	6295891	Upper Wheel Guide Bracket		1
12	6295217	Adjustment Bracket		1
13	TS-0640091	Nylon Lock Hex Nut	3/8"-16	1
14	6295219	Lock Knob		1
15	6294812	Adjustment Screw		1
16	6295221	Elevator Bracket		1
17	6294813	Spring		2
18	6294814	Guide Bar		2
19	TS-0810012	Screw	#10-24x1/4"	1
20	6294815	Bracket		1
21	6295226	Pointer		1
22	TS-0720051	Lock Washer	#10	3
23	6294816	Upper Wheel Bracket Base		1
24	6295228	Bracket Shaft		2
25	6295229	Handwheel		1
26	TS-0720081	Lock Washer	5/16"	2
27	TS-0640081	Nylon Insert Lock Nut	5/16"-18	2
28	TS-0208121	Socket Head Cap Screw	5/16"-18 x 2-1/2"	2
29	TS-0680041	Flat Washer	3/8"	4
30	TS-0060081	Hex Cap Screw	3/8"-16x1-3/4"	6
31	2013-331	Work Lamp	115V	1
32	6294818	Scale (Blade tension)		1
33	2013-333	Bushing		3
34	TS-081C022	Phillips Pan Head Machine Screw	#10-24x3/8"	2

Upper Wheel Base Assembly (2013 and 2415)

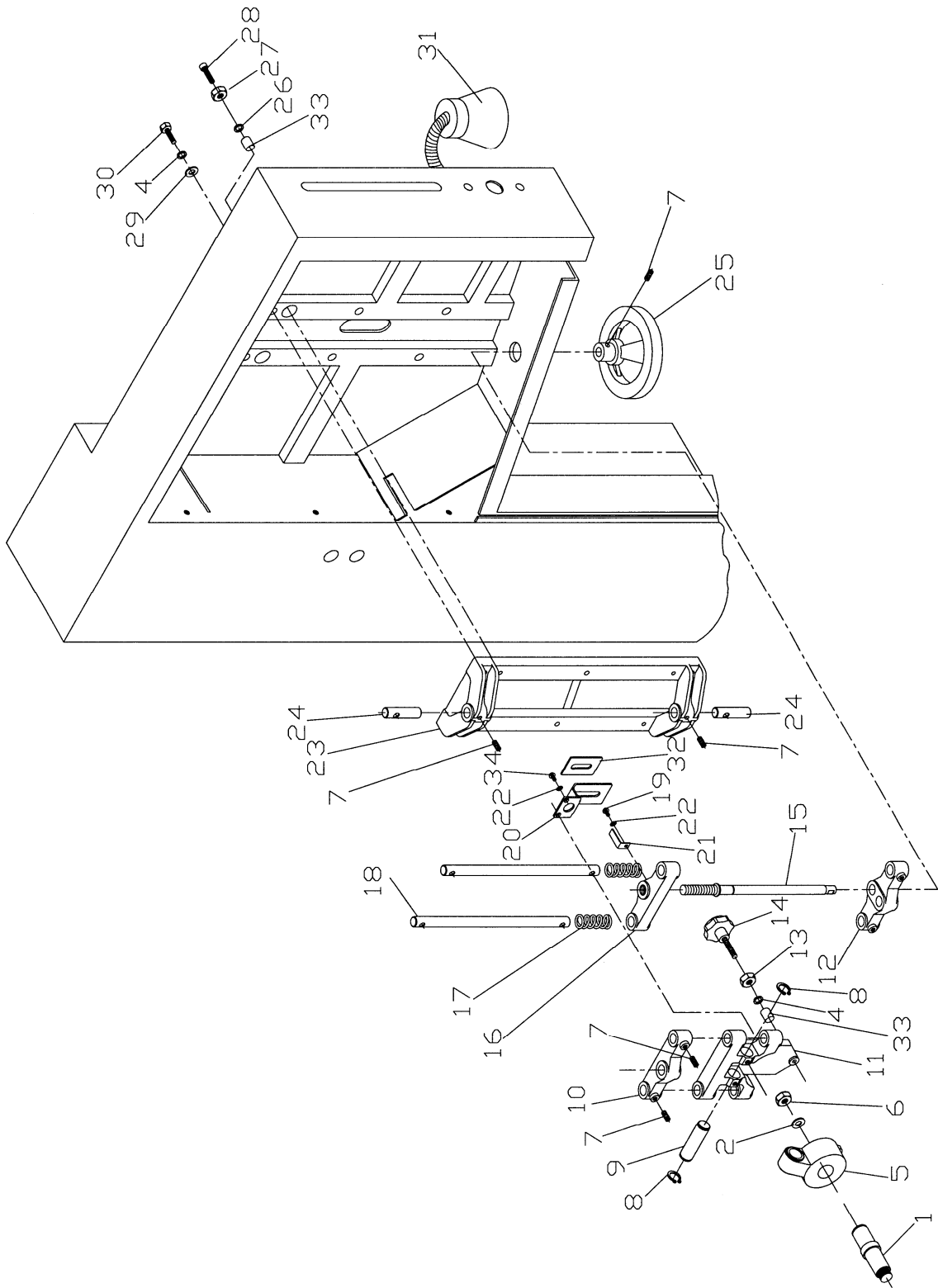

Parts List: Lower Wheel Base Assembly (2013 Band Saw)

Index No.	Part No.	Description	Size	Qty
1	TS-0207061	Socket Head Cap Screw	1/4"-20x1"	1
2	TS-0680021	Flat Washer	1/4"	5
3	6295238	Brake Pedal		1
4	6295239	Brake Bracket		2
5	TS-0561011	Hex Nut	1/4"-20	9
6	6295241	Spring		1
7	6295242	Brake Switch		1
8	TS-0640091	Nylon Insert Lock Nut	3/8"-16	1
9	6295243	Brake Wheel		1
10	6295244	Brake Belt		1
11	6295245	Brake Band		1
12	TS-0050031	Hex Cap Screw	1/4"-20x3/4"	4
13	6295247	Key	7x7x25	2
14	6295248	Shaft		1
15	6295249	Ball Bearing	6206	2
16	6295250	Bearing Base		1
17	6295251	Adjusting Screw		4
18	TS-0720091	Lock Washer	3/8"	4
19	TS-0060091	Hex Cap Screw	3/8"-16x2"	5
20	6295253	Hex Nut	M28	1
21	6295254A	Spindle Pulley (serial # 08102013704 and higher)		1
	6295254	Spindle Pulley (serial # 08102013703 and lower)		1
22	TS-0267041	Socket Set Screw	1/4"-20x3/8"	2
23	TS-0680031	Flat Washer	5/16"	10
24	TS-0720081	Lock Washer	5/16"	6
25	TS-0561021	Hex Nut	5/16"-18	5
26	6295256	Motor	2HP, 1PH	1
	2013-426SC	Starting Capacitor	500MFD, 125VAC	1
	2013-426RC	Running Capacitor	30µF, 300VAC	1
	6295331	Motor	3HP, 3PH	1
	2013-426AJB	Junction Box (not shown)	3PH	1
	2013-426AJBC	Junction Box Cover (not shown)	3PH	1
27	TS-0208081	Socket Head Cap Screw	5/16"-18x1-1/2"	4
28	6295258	Core		1
29	6295259	Core Piece		4
30	6295260	Fan Cover		1
31	6295261	Hose Connector		1
32	6295262	Air Input Valve		1
33	TS-0207041	Socket Head Cap Screw	1/4"-20x3/4"	3
34	6295264A	Motor Pulley (serial # 08102013704 and higher)		1
	6295264	Motor Pulley (serial # 08102013703 and lower)		1
35	6295265	Belt	501J	1
36	6295266	Hose		1
37	TS-0270031	Socket Set Screw	5/16"-18x3/8"	4
38	6295268	Key	7x7x40	2
39	6295269	Motor Cord	1Ph	1
	2013-439A	Motor Cord (3PH)	ST 14AWG 600V	1
41	TS-0060091	Hex Cap Screw	3/8"-16x2"	1
42	6295272	Plate		2
43	TS-2284302	Phillips Pan Head Machine Screw	M4x30	2
44	TS-1540021	Hex Nut	M4	2
45	6294830	Motor Plate		1
46	TS-0270031	Socket Set Screw	5/16"-18x3/8"	4
47	6294832	Belt Tension Bracket		1
48	TS-0051021	Hex Cap Screw	5/16"-18x5/8"	2
49	TS-0051111	Hex Cap Screw	5/16"-18x2-1/2"	1
50	TS-0640071	Nylon Insert Lock Nut	1/4"-20	2
51	TS-0680041	Flat Washer	3/8"	2
52	TS-0561031	Hex Nut	3/8"-16	4

Index No.	Part No.	Description	Size	Qty
53	TS-0720071	Lock Washer	1/4"	4
54	TS-081C032	Screw	#10-24x1/2"	4
55	TS-0720051	Lock Washer	#10	4
56	TS-069204	Flat Washer	#10	4
57	TS-0560071	Hex Nut	#10-24	4
58	2013-458A	Motor Strain Relief (not shown)	3PH,PG19	1
59	2013-459	Limit Switch Cord (not shown)	ST 18AWG 600V	1

Parts List: Lower Wheel Base Assembly (2415 Band Saw)

Index No.	Part No.	Description	Size	Qty
1	TS-0207061	Socket Head Cap Screw	1/4"-20x1"	1
2	TS-0680021	Flat Washer	1/4"	5
3	6294819	Brake Pedal		1
4	6295239	Brake Bracket		2
5	TS-0561011	Hex Nut	1/4"-20	9
6	6295241	Spring		1
7	6295242	Brake Switch		1
8	TS-0640091	Nylon Insert Lock Nut	3/8"-16	1
9	6295243A	Brake Wheel		1
10	6294820	Brake Belt		1
11	6294821	Brake Band		1
12	TS-0050031	Hex Cap Screw	1/4"-20x3/4"	4
13	6295247	Key	7x7x25	2
14	6295248A	Shaft		1
15	6295249	Ball Bearing	6206	2
16	6295250	Bearing Base		1
17	6295251	Adjusting Screw		4
18	TS-0720091	Lock Washer	3/8"	4
19	TS-0060091	Hex Cap Screw	3/8"-16x2"	5
20	6295253	Hex Nut	M28	1
21	6294822A	Spindle Pulley (serial # 08082415835 and higher)		1
	6294822	Spindle Pulley (serial # 08082415834 and lower)		1
22	TS-0267041	Socket Set Screw	1/4"-20x3/8"	2
23	TS-0680031	Flat Washer	5/16"	10
24	TS-0720081	Lock Washer	5/16"	6
25	TS-0561021	Hex Nut	5/16"-18	5
26	2415-426	Motor	3HP, 1PH	1
	2013-426SC	Starting Capacitor	500MFD, 125VAC	1
	2415-426RC	Running Capacitor	40µF, 250VAC	1
	2415-426A	Motor	5HP, 3PH	1
	2415-426AJB	Junction Box		1
	2415-426AJBC	Junction Box Cover		1
27	TS-0208081	Socket Head Cap Screw	5/16"-18x1-1/2"	4
28	6295258	Core		1
29	6295259	Core Piece		4
30	6295260	Fan Cover		1
31	6295261	Hose Connector		1
32	6295262	Air Input Valve		1
33	TS-0207041	Socket Head Cap Screw	1/4"-20x3/4"	3
34	6294825A	Motor Pulley (serial # 08082415835 and higher)		1
	6294825	Motor Pulley (serial # 08082415834 and lower)		1
35	6294826	Belt	540J	1
36	6294827	Hose		1
37	TS-0270031	Socket Set Screw	5/16"-18x3/8"	4
38	6295268	Key	7x7x40	2
39	6295269	Motor Cord	1Ph	1
	2415-439A	Motor Cord (3PH)	ST 12AWG 600V	1
41	TS-0060091	Hex Cap Screw	3/8"-16x2"	1
42	6295272	Plate		2
43	TS-2284302	Phillips Pan Head Machine Screw	M4x30	2
44	TS-1540021	Hex Nut	M4	2
45	6294830	Motor Plate		1
46	TS-0270031	Socket Set Screw	5/16"-18x3/8"	4
47	6294832	Belt Tension Bracket		1
48	TS-0051021	Hex Cap Screw	5/16"-18x5/8"	2
49	TS-0051111	Hex Cap Screw	5/16"-18x2-1/2"	1
50	TS-0640071	Nylon Lock Hex Nut	1/4"-20	2
51	TS-0680041	Flat Washer	3/8"	2
52	TS-0561031	Hex Nut	3/8"-16	4
53	TS-0720071	Lock Washer	1/4"	4

Index No.	Part No.	Description	Size	Qty
54	TS-081C032	Screw	#10-24x1/2"	4
55	TS-0720051	Lock Washer	#10	4
56	TS-069204	Flat Washer	#10	4
57	TS-0560071	Hex Nut	#10-24	4
58	2013-142A	Motor Strain Relief (not shown)	3PH,PG21-18	1
59	2013-459	Limit Switch Cord (not shown)	ST 18AWG 600V	1

Lower Wheel Base Assembly (2013 and 2415)

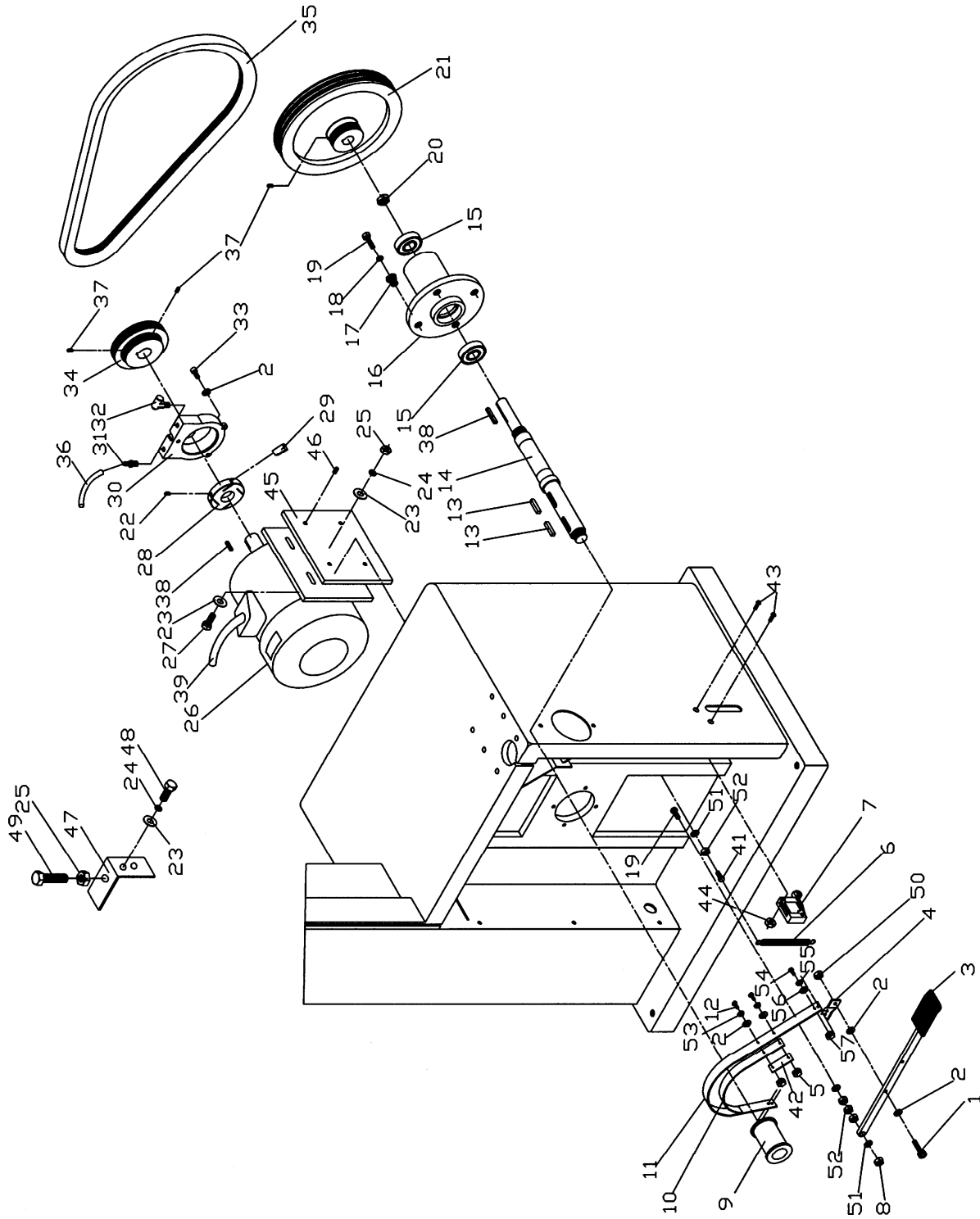

Parts List: Guide Bracket Assembly (2013 Band Saw)

Index No.	Part No.	Description	Size	Qty
1	6295275	Guide Bar Case Bracket		1
2	6295276	Cover		1
3	TS-0081031	Hex Cap Screw	5/16"-18x3/4"	4
4	TS-0050011	Hex Cap Screw	1/4"-20x1/2"	1
5	6295278	Pointer		1
6	6295279	Guide Bar		1
7	6295280	Worm		1
8	6295281	Miniature Ball Bearing	609	1
9	6295282	C-Ring	S-12	2
10	6295283	Gear		1
11	TS-0208071	Socket Head Cap Screw	5/16"-18x1-1/4"	6
12	6295285	Gear Base		1
13	6295286	Set Block		1
14	6295287	Thumb Screw	1/4"-20x1/4"	1
15	6295288	Inner Blade Guard		1
16	6295289	Blade Guard		1
17	TS-0050021	Hex Cap Screw	1/4"-20x5/8"	4
18	TS-0720071	Lock Washer	1/4"	4
19	TS-0680021	Flat Washer	1/4"	7
20	6295291	Guide Bar Bracket		1
21	TS-0270131	Socket Set Screw	5/16"-18x2"	1
22	6295293	Locking Handle	1/4"x3/4"	1
23	TS-1521011	Socket Set Screw	M4x4	4
24	6295294	Knob		2
25	TS-0267021	Socket Set Screw	1/4"-20x1/4"	6
26	6295296	Lever Shaft		1
27	6295297	Hand Nut		2
28	6295298	Bolt		1
29	6295299	Support Bearing Bracket (L)		1
30	6295300	Adjustment Bolt		1
31	TS-0207041	Socket Head Cap Screw	1/4"-20x3/4"	2
32	6295302	Support Bearing Shaft		1
33	6295303	Spacer		2
34	6295304	C-Ring	S-15	4
35	6295305	Ball Bearing	6202	5
36	6295306	Shaft		2
37	6295307	Knob	3/8"-16x2"	1
38	TS-0208071	Socket Head Cap Screw	5/16"-18x1-1/4"	4
39	TS-0720081	Lock Washer	5/16"	6
40	6295308	Ball Bearing		1
41	6295309	Bracket		1
42	TS-0208041	Socket Head Cap Screw	5/16"-18x3/4"	2
43	6295311	Plastic Washer		1
44	6295312	Handwheel		1
45	6295313	Handle		1
46	6295314	Guide Wheel Assembly		1
47	6295315	Blade Support Shaft w/Bearing		1
48	6295316	Lower Guide Bracket		1
49	TS-0050051	Hex Cap Screw	1/4"-20x1"	2
50	6295318	Bracket		1
51	TS-0680031	Flat Washer	5/16"	4
52	TS-0207021	Socket Head Cap Screw	1/4"-20x1/2"	4
53	6295320	Lower Blade Guard		1
54	6295321	Locking Nut		1
55	6295322	C-Ring	E-5	1
56	6295323	Air Nozzle		1
57	6295324	Hose Clamp		1
58	TS-081C022	Screw	#10-24x3/8"	1
59	6295325	Bracket		1
60	TS-0560071	Hex Nut	#10-24	1

Index No.	Part No.	Description	Size	Qty
61	TS-069204	Flat Washer	#10	1
62	6295327	Support Bearing Shaft (R)		1
63	TS-0270031	Socket Set Screw	5/16"-18x3/8"	3
64	TS-081C032	Phillips Pan Head Machine Screw	#10-24x1/2"	1
65	TS-0270051	Socket Set Screw	5/16"-18x1/2"	4
66	TS-0267041	Socket Set Screw	1/4"-20x3/8"	4
67	2013-567	Eccentric Set Screw		1

Parts List: Guide Bracket Assembly (2415 Band Saw)

Index No.	Part No.	Description	Size	Qty
1	6295275	Guide Bar Case Bracket		1
2	6295276	Cover		1
3	TS-0081031	Hex Cap Screw	5/16"-18x3/4"	4
4	TS-0050011	Hex Cap Screw	1/4"-20x1/2"	1
5	6295278	Pointer		1
6	6294835	Guide Bar		1
7	6295280	Worm		1
8	6295281	Miniature Ball Bearing	609	1
9	6295282	C-Ring	S-12	2
10	6295283	Gear		1
11	TS-0208071	Socket Head Cap Screw	5/16"-18x1-1/4"	6
12	6295285	Gear Base		1
13	6295286	Set Block		1
14	6295287	Thumb Screw	1/4"-20x1/4"	1
15	6295288	Inner Blade Guard		1
16	6295289	Blade Guard		1
17	TS-0050021	Hex Cap Screw	1/4"-20x5/8"	4
18	TS-0720071	Lock Washer	1/4"	4
19	TS-0680021	Flat Washer	1/4"	7
20	6295291	Guide Bar Bracket		1
21	TS-0270131	Socket Set Screw	5/16"-18x2"	1
22	6295293	Locking Handle	1/4"x3/4"	1
23	TS-1521011	Socket Set Screw	M4x4	4
24	6295294	Knob		2
25	TS-0267021	Socket Set Screw	1/4"-20x1/4"	6
26	6295296	Lever Shaft		1
27	6295297	Hand Nut		2
28	6295298	Bolt		1
29	6295299	Support Bearing Bracket (L)		1
30	6295300	Adjustment Bolt		1
31	TS-0207041	Socket Head Cap Screw	1/4"-20x3/4"	2
32	6295302	Support Bearing Shaft		1
33	6295303	Spacer		2
34	6295304	C-Ring	S-15	4
35	6295305	Ball Bearing	6202	5
36	6295306	Shaft		2
37	6295307	Knob	3/8"-16x2"	1
38	TS-0208071	Socket Head Cap Screw	5/16"-18x1-1/4"	4
39	TS-0720081	Lock Washer	5/16"	6
40	6295308	Ball Bearing		1
41	6295309	Bracket		1
42	TS-0208041	Socket Head Cap Screw	5/16"-18x3/4"	2
43	6295311	Plastic Washer		1
44	6295312	Handwheel		1
45	6295313	Handle		1
46	6295314	Guide Wheel Assembly		1
47	6295315	Blade Support Shaft w/Bearing		1
48	6295316	Lower Guide Bracket		1
49	TS-0050051	Hex Cap Screw	1/4"-20x1"	2
50	6295318	Bracket		1
51	TS-0680031	Flat Washer	5/16"	4
52	TS-0207021	Socket Head Cap Screw	1/4"-20x1/2"	4
53	6295320	Lower Blade Guard		1
54	6295321	Locking Nut		1
55	6295322	C-Ring	E-5	1
56	6295323	Air Nozzle		1
57	6295324	Hose Clamp		1
58	TS-081C022	Screw	#10-24x3/8"	1
59	6295325	Bracket		1
60	TS-0560071	Hex Nut	#10-24	1

Index No.	Part No.	Description	Size	Qty
61	TS-069204	Flat Washer	#10	1
62	6295327	Support Bearing Shaft (R)		1
63	TS-0270031	Socket Set Screw	5/16"-18x3/8"	3
64	TS-081C032	Phillips Pan Head Machine Screw	#10-24x1/2"	1
65	TS-0270051	Socket Set Screw	5/16"-18x1/2"	4
66	TS-0267041	Socket Set Screw	1/4"-20x3/8"	4
67	2013-567	Eccentric Set Screw		1

Guide Bracket Assembly (2013 and 2415)

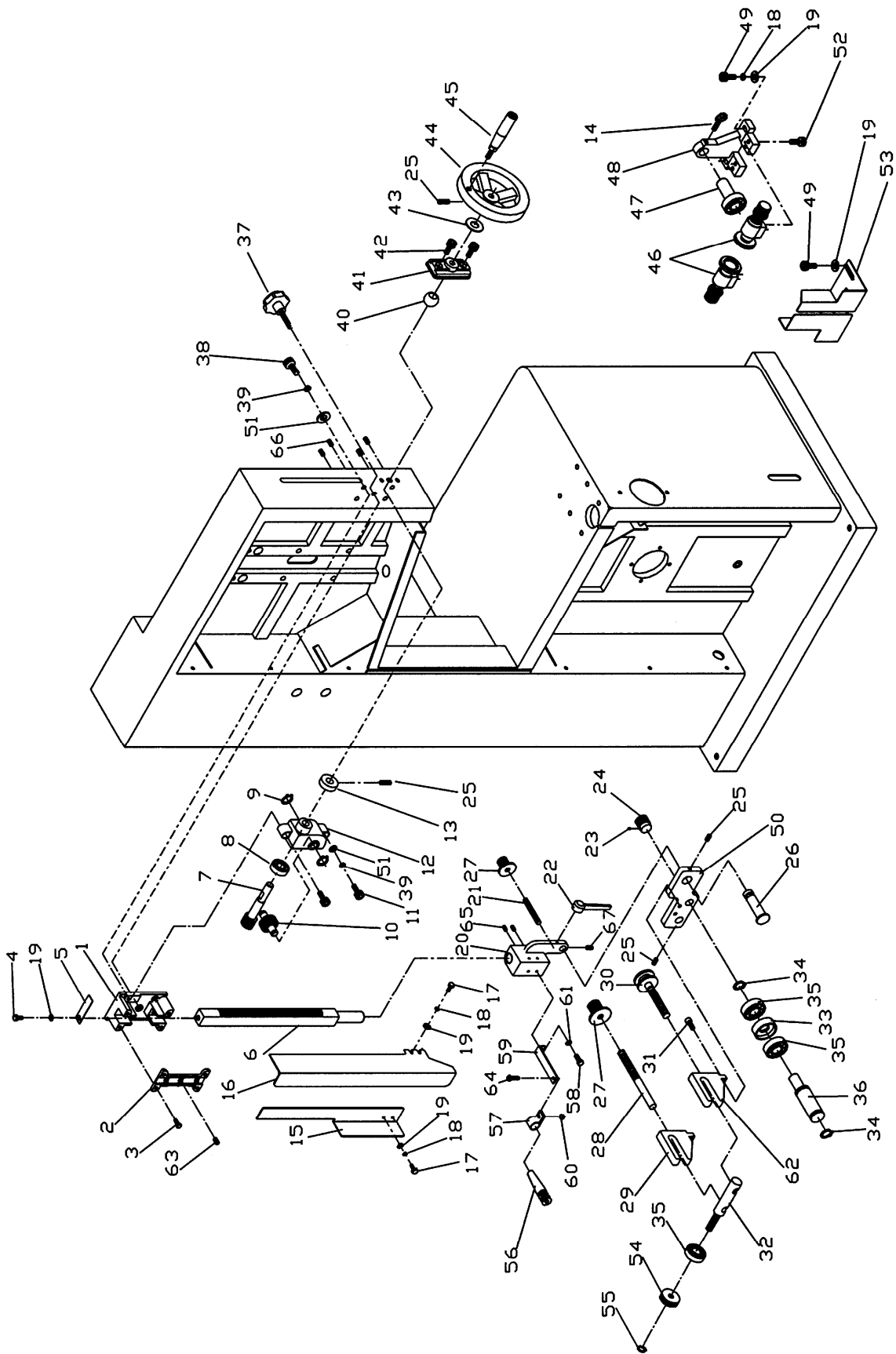

Magnetic Switch

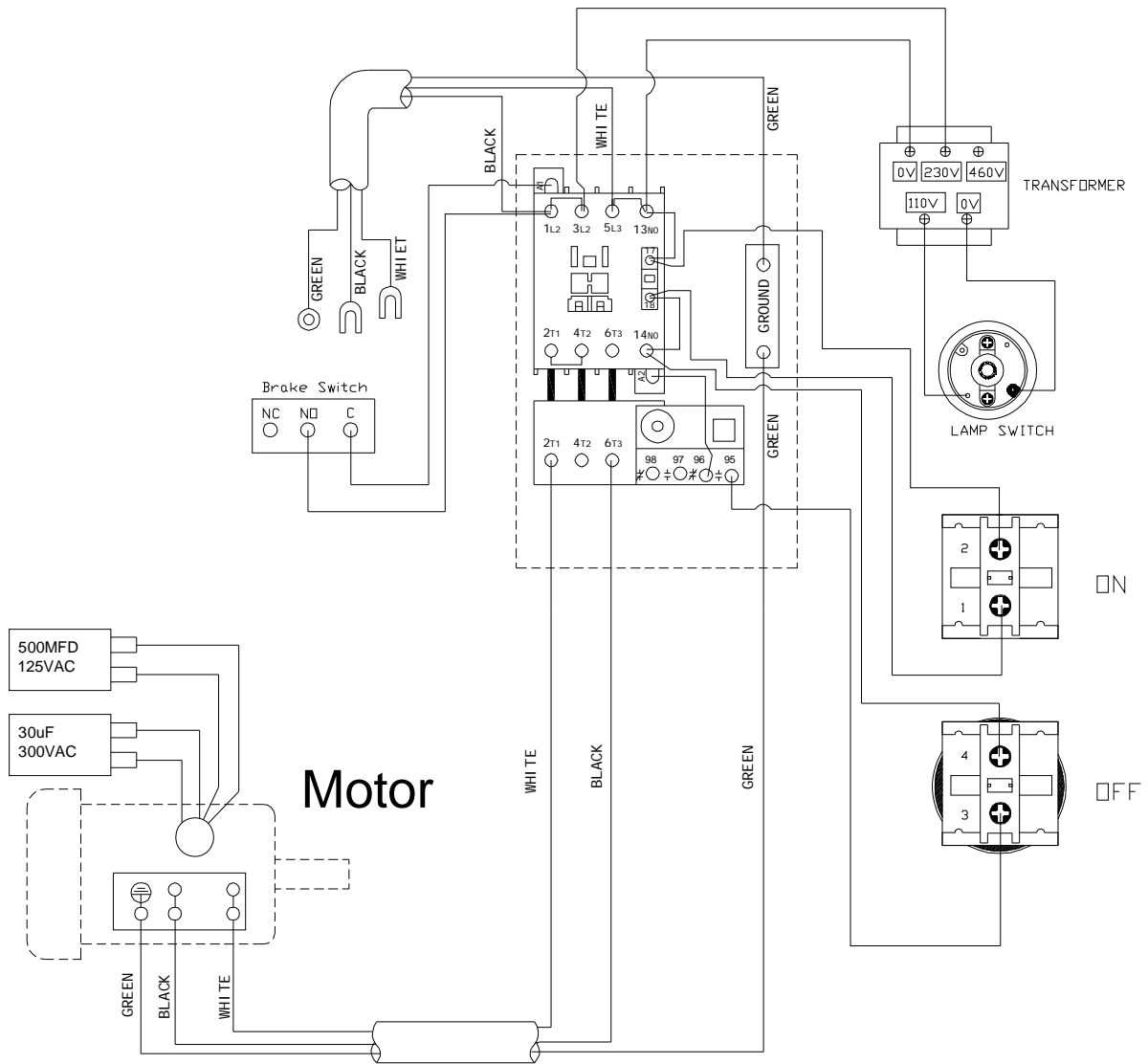

2013 Band Saw ONLY

Electrical Connections: 230 Volt, Single Phase – Model 2415 Band Saw ONLY

Magnetic Switch

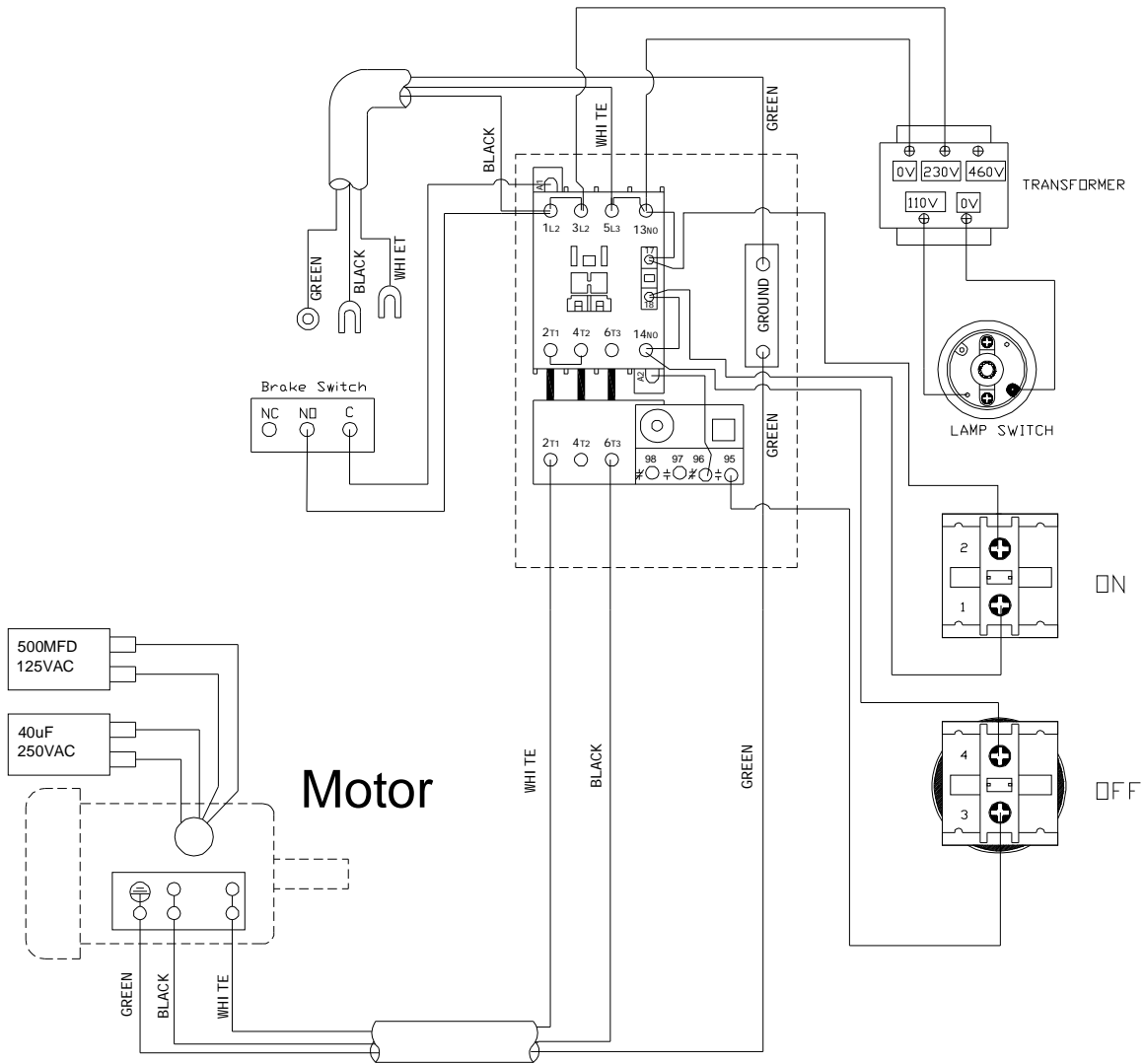

2415 Band Saw ONLY

Magnetic Switch

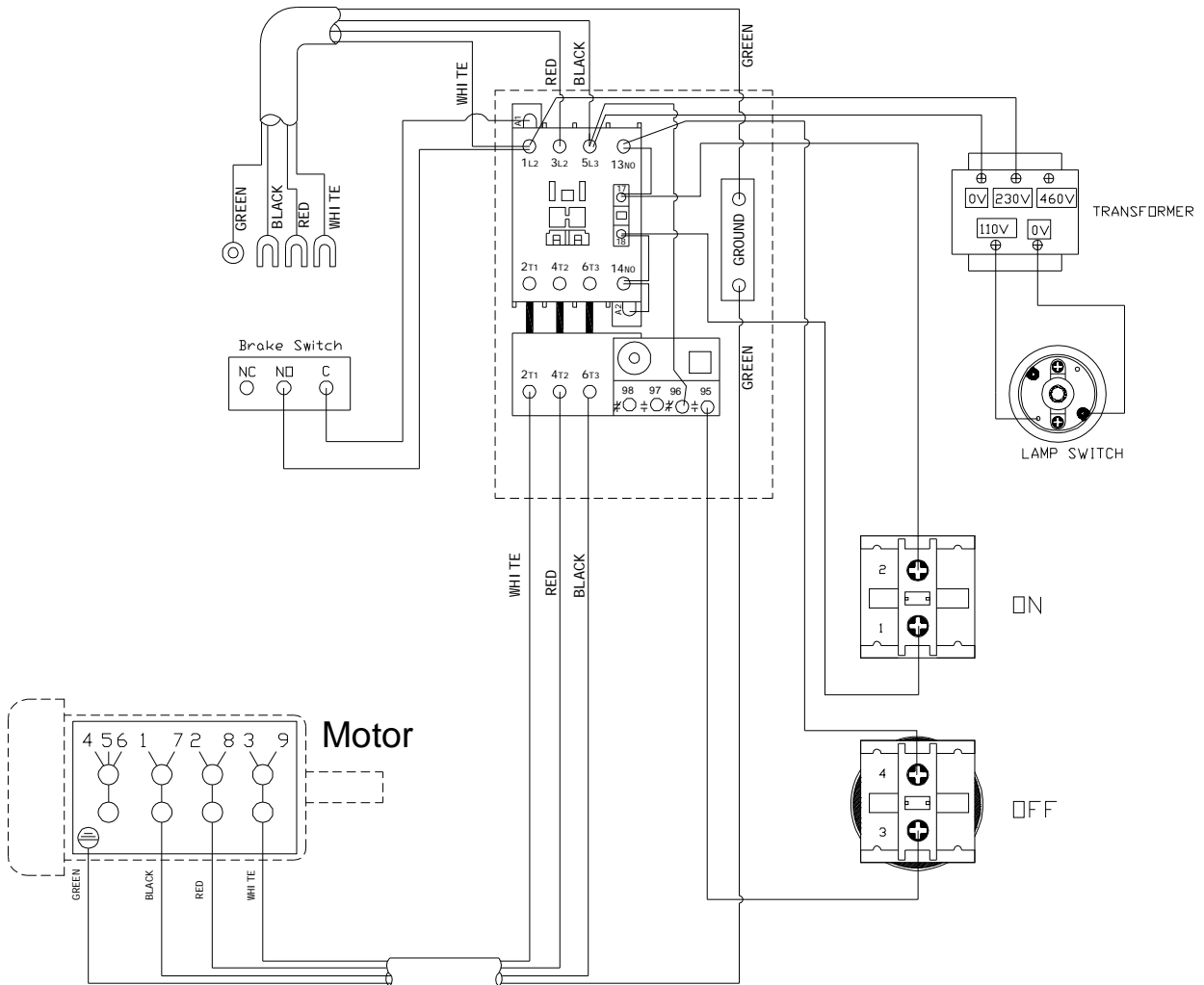

Magnetic Switch

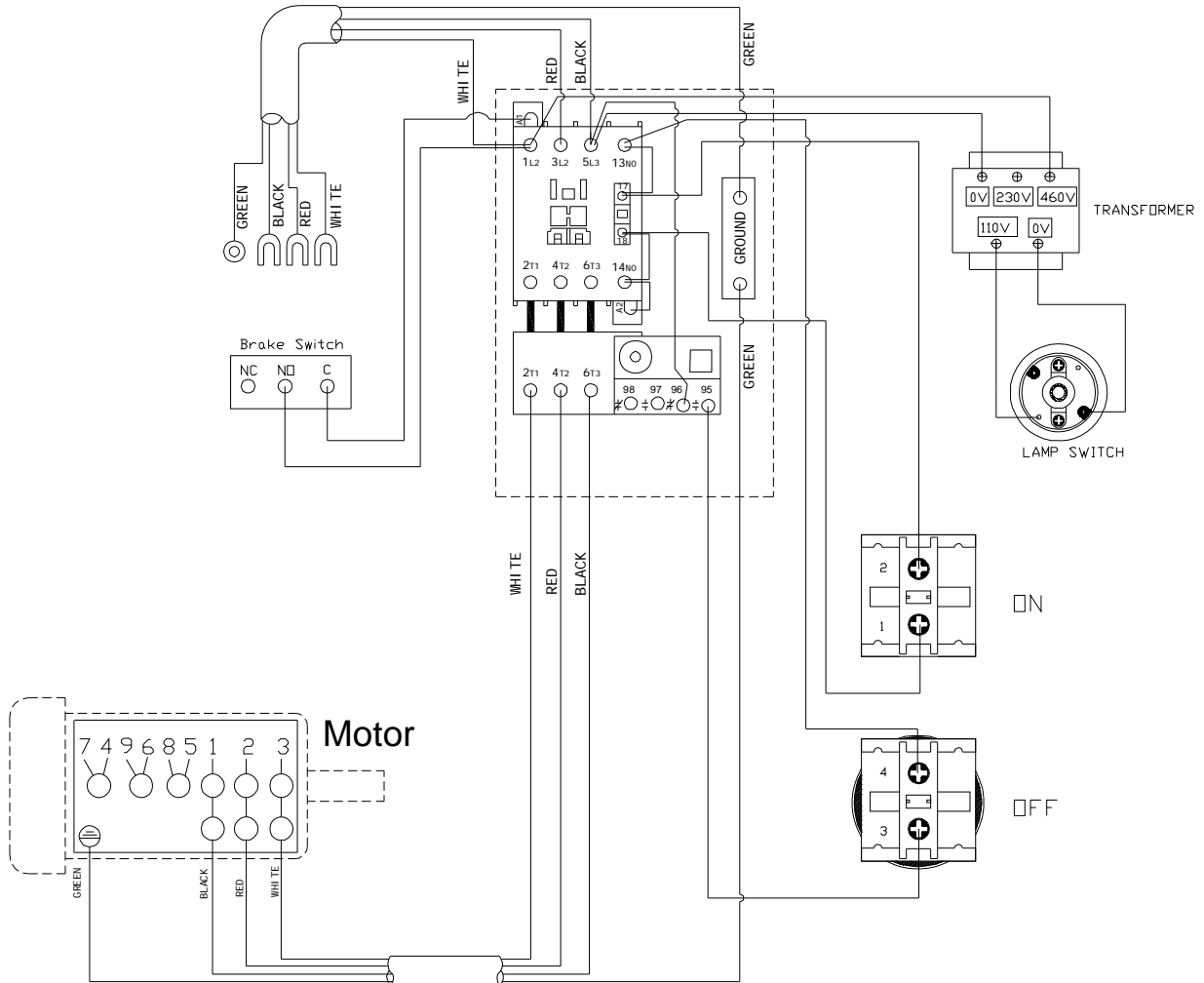

This page intentionally left blank.

This page intentionally left blank.



427 New Sanford Rd.
LaVergne, TN 37086
Phone: 800-274-6848
www.powermatic.com

Free Manuals Download Website

<http://myh66.com>

<http://usermanuals.us>

<http://www.somanuals.com>

<http://www.4manuals.cc>

<http://www.manual-lib.com>

<http://www.404manual.com>

<http://www.luxmanual.com>

<http://aubethermostatmanual.com>

Golf course search by state

<http://golfingnear.com>

Email search by domain

<http://emailbydomain.com>

Auto manuals search

<http://auto.somanuals.com>

TV manuals search

<http://tv.somanuals.com>