

POWERWARE® FERRUPS FE/QFE UPS

User's Guide

500 VA–18 kVA, 50 and 60 Hz



POWERWARE® FERRUPS FE/QFE UPS

User's Guide

500 VA–18 kVA, 50 and 60 Hz

www.powerware.com

Class A EMC Statements

FCC Part 15

NOTE This equipment has been tested and found to comply with the limits for a Class A digital device, pursuant to part 15 of the FCC Rules. These limits are designed to provide reasonable protection against harmful interference when the equipment is operated in a commercial environment. This equipment generates, uses, and can radiate radio frequency energy and, if not installed and used in accordance with the instruction manual, may cause harmful interference to radio communications. Operation of this equipment in a residential area is likely to cause harmful interference in which case the user will be required to correct the interference at his own expense.

ICES-003

This Class A Interference Causing Equipment meets all requirements of the Canadian Interference Causing Equipment Regulations ICES-003.

Cet appareil numérique de la classe A respecte toutes les exigences du Règlement sur le matériel brouilleur du Canada.

For Users in Germany

We hereby certify that the uninterruptible power system (QFE 500 VA, 700 VA, 850 VA, 1.15 kVA, 1.4 kVA, 1.8 kVA, 2.1 kVA, 3.1 kVA, 4.3 kVA, 5.3 kVA, 7 kVA, 10 kVA, 12.5 kVA, and 18 kVA) complies with the RFI suppression requirements of Vfg. 243/1991 and Vfg. 46/1992. The German Postal Service was notified that the equipment is being marketed. The German Postal Service has the right to retest the equipment and verify compliance.

Hiermit wird bescheinigt, daß die unterbrechungsfreie Stromversorgung (QFE 500 VA, 700 VA, 850 VA, 1.15 kVA, 1.4 kVA, 1.8 kVA, 2.1 kVA, 3.1 kVA, 4.3 kVA, 5.3 kVA, 7 kVA, 10 kVA, 12.5 kVA, and 18 kVA) in Übereinstimmung mit den Bestimmungen der Vfg. 243/1991 und Vfg. 46/1992 funktentstört ist. Der Deutschen Bundespost wurde das Inverkehrbringen dieses Gerätes angezeigt und die Berechtigung zur Überprüfung der Serie auf Einhaltung der Bestimmung eingeräumt.

Powerware reserves the right to change specifications without prior notice.

Powerware and CheckUPS are registered trademarks and EnviroCom is a trademark of Powerware Corporation.

Microsoft and Windows are registered trademarks of Microsoft Corporation.

HyperTerminal is a registered trademark of Hilgraeve.

TeleVideo is a registered trademark of TeleVideo, Inc.

WYSE is a registered trademark of WYSE Technology Inc.

©Copyright 2002 Powerware, Raleigh, NC, USA. All rights reserved. No part of this document may be reproduced in any way without the express written approval of Powerware.



TABLE OF CONTENTS

1 Introduction	1
Identifying Your UPS	1
2 Safety Warnings	3
3 UPS Startup	17
Startup for the FE and QFE 500 VA–3.1 kVA UPS	17
Startup for the FE and QFE 4.3–18 kVA UPS	19
Rear Panels	23
4 Operation	25
Front Panel Indicators	25
Using the Control Panel	27
Changing Operating Modes	27
Entering Passwords	28
Displaying and Changing Parameters	29
Locking and Unlocking the Control Panel	29
Using the Configuration Menu	30
Automatic System Test	31
Logic Test	31
Inverter Test	31
Battery Test	31
Parameters	32
UPS Shutdown	35
Extended Power Outages	37
5 Communication	39
Powerware Software Suite	39
Communication Port	40
Connecting a Terminal or Computer to the RS-232 Port	41
Entering Commands from a Terminal or Computer	44
Remote Monitoring	47
Remote Shutdown	47

6 Options	49
Bypass Switches	49
Control Panel	49
Environmental Monitoring	49
Extended Runtimes	49
Warranties	49
7 Maintenance	51
8 Specifications	53
9 Troubleshooting	59
Alarms	59
Alarm and Inverter Logs	62
Reading the Alarm Log from a Control Panel	62
Reading the Inverter Log from a Control Panel	63
Reading the Alarm Log from a Terminal or Computer	64
Reading the Inverter Log from a Terminal or Computer	65
Alarm Code Summary	65
Service and Support	66



CHAPTER 1

INTRODUCTION

Welcome to the growing Powerware® FERRUPS uninterruptible power system (UPS) family. This UPS represents a breakthrough in the design of advanced, online UPSs.

Identifying Your UPS



NOTE Before starting up the UPS, verify that it has been installed according to the *Powerware FERRUPS FE/QFE UPS (500 VA–18 kVA) Installation Guide*.

FERRUPS UPSs come in different sizes (see Figure 1). If your UPS is a 500 VA–3.1 kVA model, continue with “Startup for the FE and QFE 500 VA–3.1 kVA UPS” on page 17. If your UPS is a 4.3–18 kVA model, continue with “Startup for the FE and QFE 4.3–18 kVA UPS” on page 19.

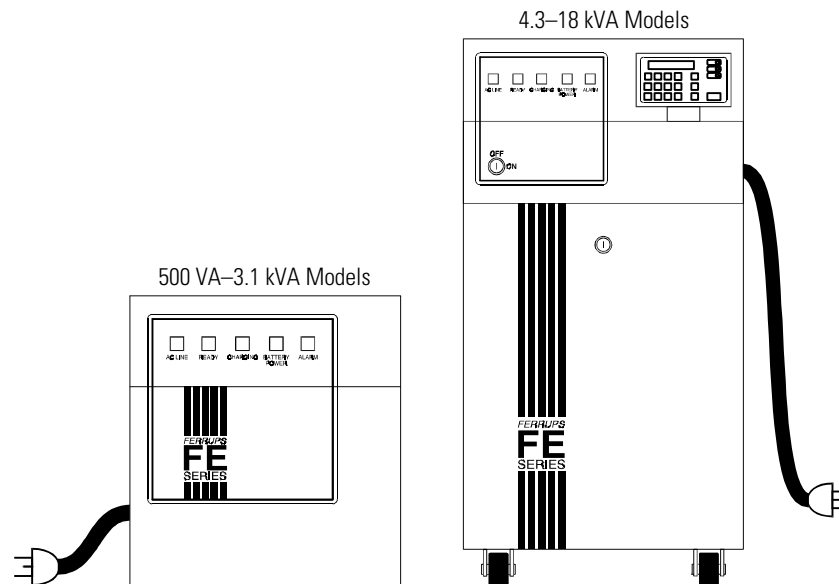

Figure 1. FERRUPS UPS



CHAPTER 2

SAFETY WARNINGS

Read the following precautions before you install the UPS.

IMPORTANT SAFETY INSTRUCTIONS

SAVE THESE INSTRUCTIONS. This manual contains important instructions that you should follow during installation and maintenance of the UPS and batteries. Please read all instructions before operating the equipment and save this manual for future reference.

DANGER



This UPS contains **LETHAL VOLTAGES**. All repairs and service should be performed by **AUTHORIZED SERVICE PERSONNEL ONLY**. There are **NO USER SERVICEABLE PARTS** inside the UPS.

WARNING



- This UPS contains its own energy source (batteries). The output receptacles may carry live voltage even when the UPS is not connected to an AC supply.
- Do not remove or unplug the input cord when the UPS is turned on. This removes the safety ground from the UPS and the equipment connected to the UPS.
- To reduce the risk of fire or electric shock, install this UPS in a temperature and humidity controlled, indoor environment, free of conductive contaminants. Ambient temperature must not exceed 40°C (104°F). Do not operate near water or excessive humidity (95% max).
- To comply with international standards and wiring regulations, the total equipment connected to the output of this UPS must not have an earth leakage current greater than 1.5 milliamperes.



CAUTION

- Batteries can present a risk of electrical shock or burn from high short-circuit current. Observe proper precautions. Servicing should be performed by qualified service personnel knowledgeable of batteries and required precautions. Keep unauthorized personnel away from batteries.
- Proper disposal of batteries is required. Refer to your local codes for disposal requirements.
- Never dispose of batteries in a fire. Batteries may explode when exposed to flame.

Sikkerhedsanvisninger

VIGTIGE SIKKERHEDSANVISNINGER GEM DISSE ANVISNINGER DENNE BRUGERVEJLEDNING INDEHOLDER VIGTIGE SIKKERHEDSANVISNINGER



FARE

Denne UPS indeholder LIVSFARLIG HØJSPÆNDING. Alle reparationer og vedligeholdelse bør kun udføres af en AUTORISERET SERVICETEKNIKER. Ingen af UPS'ens indvendige dele kan repareres af brugeren.



ADVARSEL!

- Denne UPS indeholder egen energiforsyning (batterier). Udgangsnetstikkene kan lede strøm, selv når UPS'en ikke er tilsat en AC-energikilde.
- Netledningen må ikke fjernes og stikket må ikke trækkes ud, mens UPS'en er tændt. Dette fjerner sikkerhedsjorden fra UPS'en og fra det udstyr, der er sat til.
- Installér denne UPS i et temperatur- og fugtighedskontrolleret indendørsmiljø, frit for ledende forureningsstoffer for at formindske risikoen for brand og elektrisk stød. Rumtemperaturen må ikke overstige 40°C. UPS'en bør ikke betjenes nær vand eller høj fugtighed (maksimalt 95%).
- I overensstemmelse med internationale normer og bestemmelser for el-installation må det udstyr, der er forbundet til udgangen af denne UPS, tilsammen ikke overskride en jordafdelingsspænding på mere end 1,5 milliamperere.



ADVARSEL

- Batterier kan udgøre en fare for elektrisk stød eller forbrændinger forårsaget af høj kortslutningsspænding. De korrekte forholdsregler bør overholdes.
- Korrekt bortskaffelse af batterier er påkrævet. Overhold gældende lokale regler for bortskaffelsesprocedurer.
- Skaf dig aldrig af med batterierne ved at brænde dem. Batterierne kan eksplodere ved åben ild.

Belangrijke Veiligheidsinstructies

BELANGRIJKE VEILIGHEIDSINSTRUCTIES BEWAAR DEZE INSTRUCTIES DEZE HANDLEIDING BEVAT BELANGRIJKE VEILIGHEIDSINSTRUCTIES



GEVAAR

Deze UPS bevat LEVENSGEVAARLIJKE ELEKTRISCHE SPANNING. Alle reparaties en onderhoud dienen UITSLUITEND DOOR ERKEND SERVICEPERSONEEL te worden uitgevoerd. Er bevinden zich GEEN ONDERDELEN in de UPS die DOOR DE GEBRUIKER kunnen worden GEREPAREERD.



WAARSCHUWING

- Deze UPS bevat zijn eigen energiebron (batterijen). De uitgangsaansluitingen kunnen onder spanning staan wanneer de UPS niet op een wisselstroom voeding is aangesloten.
- Verwijder de ingang snoer niet of haal de stekker van de ingang snoer er niet uit terwijl de UPS aan staat. Hierdoor zou de UPS en uw aangesloten apparatuur geen aardebeveiliging meer hebben.
- Teneinde de kans op brand of elektrische schok te verminderen dient deze UPS in een gebouw met temperatuur- en vochtigheidsregeling te worden geïnstalleerd, waar geen geleidende verontreinigingen aanwezig zijn. De omgevingstemperatuur mag 40°C niet overschrijden. Niet gebruiken in de buurt van water of bij zeer hoge vochtigheid (max. 95%).
- Om aan de internationale normen en bedradingsvoorschriften te voldoen mag de gehele apparatuur die op de uitgang van deze UPS is aangesloten, geen aardlekstroom van meer dan 1,5 milliampère hebben.



OPGELET

- Batterijen kunnen gevaar voor elektrische schok of brandwonden veroorzaken als gevolg van een hoge kortsluitstroom. Volg de desbetreffende aanwijzingen op.
- De batterijen moeten op de juiste wijze worden opgeruimd. Raadpleeg hiervoor uw plaatselijke voorschriften.
- Nooit batterijen in het vuur gooien. De batterijen kunnen ontploffen.

Tarkeita Turvaohjeita

TÄRKEITÄ TURVAOHJEITA - SUOMI SÄILYÄ NÄMÄ OHJEET TÄMÄ OPAS SISÄLTÄÄ TÄRKEITÄ TURVAOHJEITA



VAARA

Tämä UPS sisältää HENGENVAARALLISIA JÄNNITTEITÄ. Kaikki korjaukset ja huollot on jätettävä VAIN VALTUUTETUN HUOLTOHENKILÖN TOIMEKSI. UPS ei sisällä MITÄÄN KÄYTTÄJÄN HUOLLETTAVIA OSIA.



VAROITUS

- Tämä UPS sisältää oman energialähteen (akuston). Ulostuloliittimissä voi olla jännite, kun UPS ei ole liitettynä verkkojännitteeseen.
- Älä poista tai irrota sisääntulojohtoa, kun UPS on kytkettynä. Tämä poistaa turvamaadoituksen UPS-laitteesta ja siihen liitetystä laitteistosta.
- Vähentääksesi tulipalon ja sähköiskun vaaraa asenna tämä UPS sisätiloihin, joissa lämpötila ja kosteus on säädettävissä ja joissa ei ole virtaa johtavia epäpuhtauksia. Ympäristön lämpötila ei saa ylittää 40 °C. Älä käytä lähellä vettä ja vältä kosteita tiloja (95 % maksimi).
- Kansainväliset normit ja johdotusmääräykset vaativat, että kaikkien tämän UPS-laitteen ulostulokytkentöjen yhteinen maavuotovirta ei ylitä 1,5 milliampeeria (mA).

VARO

- Akusto saattaa aiheuttaa sähköiskun tai syttyä tuleen, jos akusto kytketään oikosulkuun. Noudata asianmukaisia ohjeita.
- Akusto täytyy hävittää säädösten mukaisella tavalla. Noudata paikallisia määräyksiä.
- Älä koskaan heitä akkuja tuleen. Ne voivat räjähtää.

Consignes de sécurité

**CONSIGNES DE SÉCURITÉ IMPORTANTES
CONSERVER CES INSTRUCTIONS
CE MANUEL CONTIENT DES CONSIGNES DE SÉCURITÉ
IMPORTANTES**

DANGER!

Cet onduleur contient des TENSIONS MORTELLES. Toute opération d'entretien et de réparation doit être EXCLUSIVEMENT CONFIEE A UN PERSONNEL QUALIFIE AGRÉÉ. AUCUNE PIÈCE RÉPARABLE PAR L'UTILISATEUR ne se trouve dans l'onduleur.

AVERTISSEMENT!

- Cet onduleur renferme sa propre source d'énergie (batteries). Les prises de sortie peuvent être sous tension même lorsque l'onduleur n'est pas branché sur le secteur.
- Ne pas retirer le cordon d'alimentation lorsque l'onduleur est sous tension sous peine de supprimer la mise à la terre de l'onduleur et du matériel connecté.
- Pour réduire les risques d'incendie et de décharge électrique, installer l'onduleur uniquement à l'intérieur, dans un lieu dépourvu de matériaux conducteurs, où la température et l'humidité ambiantes sont contrôlées. La température ambiante ne doit pas dépasser 40 °C. Ne pas utiliser à proximité d'eau ou dans une atmosphère excessivement humide (95 % maximum).
- Afin d'être conforme aux normes et règlements internationaux de câblage, le courant de fuite à la terre de la totalité du matériel branché sur la sortie de l'onduleur ne doit pas dépasser 1,5 mA.



ATTENTION!

- Les batteries peuvent présenter un risque de décharge électrique ou de brûlure par des courts-circuits de haute intensité. Prendre les précautions nécessaires.
- Une mise au rebut réglementaire des batteries est obligatoire. Consulter les règlements en vigueur dans votre localité.
- Ne jamais jeter les batteries au feu. L'exposition aux flammes risque de les faire exploser.

Sicherheitswarnungen

WICHTIGE SICHERHEITSANWEISUNGEN AUFBEWAHREN. DIESES HANDBUCH ENTHÄLT WICHTIGE SICHERHEITSANWEISUNGEN.



WARNUNG

Die USV führt lebensgefährliche Spannungen. Alle Reparatur- und Wartungsarbeiten sollten nur von Kundendienstfachleuten durchgeführt werden. Die USV enthält keine vom Benutzer zu wartenden Komponente.



ACHTUNG

- Diese USV ist mit einer eigenen Energiequelle (Batterie) ausgestattet. An den Ausgangssteckdosen kann auch dann Spannung anliegen, wenn die USV nicht an einer Wechselspannungsquelle angeschlossen ist.
- Das Eingangskabel nicht entfernen oder abziehen, während die USV eingeschaltet ist, weil hierdurch die Sicherheitserdung von der USV und den daran angeschlossenen Geräten entfernt wird.
- Um die Brand- oder Elektroschockgefahr zu verringern, diese USV nur in Gebäuden mit kontrollierter Temperatur und Luftfeuchtigkeit installieren, in denen keine leitenden Schmutzstoffen vorhanden sind. Die Umgebungstemperatur darf 40°C nicht übersteigen. Die USV nicht in der Nähe von Wasser oder in extrem hoher Luftfeuchtigkeit (max. 95 %) betreiben.
- Um internationale Normen und Verdrahtungsvorschriften zu erfüllen, dürfen die an den Ausgang dieser USV angeschlossenen Geräte zusammen einen Erdschlußstrom von insgesamt 1,5 Milliampere nicht überschreiten.



VORSICHT!

- Batterien können aufgrund des hohen Kurzschlußstroms Elektroschocks oder Verbrennungen verursachen. Die entsprechenden Vorsichtsmaßnahmen sind unbedingt zu beachten.
- Die Batterien müssen ordnungsgemäß entsorgt werden. Hierbei sind die örtlichen Bestimmungen zu beachten.
- Batterien niemals verbrennen, da sie explodieren können.

Προειδοποιήσεις Ασφάλειας

ΣΗΜΑΝΤΙΚΕΣ ΟΔΗΓΙΕΣ ΑΣΦΑΛΕΙΑΣ ΦΥΛΑΞΤΕ ΑΥΤΕΣ ΤΙΣ ΟΔΗΓΙΕΣ ΤΟ ΠΑΡΟΝ ΕΓΧΕΙΡΙΔΙΟ ΠΕΡΙΕΧΕΙ ΣΗΜΑΝΤΙΚΕΣ ΟΔΗΓΙΕΣ ΑΣΦΑΛΕΙΑΣ



ΚΙΝΔΥΝΟΣ

Αυτό το UPS περιέχει ΘΑΝΑΤΗΦΟΡΑ ΤΑΣΗ. Όλες οι επισκευές και οι συντηρήσεις πρέπει να γίνονται ΜΟΝΟ ΑΠΟ ΕΞΟΥΣΙΟΔΟΤΗΜΕΝΟ ΓΙΑ ΤΗ ΣΥΝΤΗΡΗΣΗ ΠΡΟΣΩΠΙΚΟ. Το UPS ΔΕΝ ΠΕΡΙΕΧΕΙ ΚΑΝΕΝΑ ΕΞΑΡΤΗΜΑ ΠΟΥ ΝΑ ΜΠΟΡΕΙ ΝΑ ΕΠΙΣΚΕΥΑΣΤΕΙ ΑΠΟ ΤΟ ΧΡΗΣΤΗ.



ΠΡΟΕΙΔΟΠΟΙΗΣΗΚ

- Το συγκεκριμένο UPS περιέχει τη δική του πηγή ενέργειας (συσσωρευτές). Οι ρευματοδότες εξόδου μπορεί να έχουν ενεργό τάση ακόμη και όταν το UPS δεν είναι συνδεδεμένο σε πηγή εναλλασσόμενου ρεύματος (AC).
- Μην βγάξετε από την πρίζα το καλώδιο τροφοδοσίας όταν το UPS είναι ανοιχτό. Μ' αυτό τον τρόπο αφαιρείτε τη γείωση ασφαλείας από το UPS και από τον εξοπλισμό που είναι συνδεδεμένος με το UPS.
- Για να μειώσετε τον κίνδυνο πυρκαγιάς ή ηλεκτροπληξίας, εγκαταστήστε το συγκεκριμένο UPS σε εσωτερικό χώρο με ελεγχόμενη θερμοκρασία και υγρασία, ο οποίος να μην περιέχει αγωγίμα υλικά. Η θερμοκρασία περιβάλλοντος δεν πρέπει να ξεπερνάει τους 40° C. Μη χρησιμοποιείτε το UPS κοντά σε νερό ή υπερβολική υγρασία (μέγιστη τιμή: 95%).

- Για να συμφωνεί με τα διεθνή πρότυπα και τους κανονισμούς καλωδίωσης, το ρεύμα διαρροής προς τη γη ολόκληρου του εξοπλισμού, που είναι συνδεδεμένος με την έξοδο του συγκεκριμένου UPS, δεν πρέπει να είναι μεγαλύτερο από 1,5 mA.

ΠΡΟΣΟΧΗ



- Οι συσσωρευτές μπορεί να προκαλέσουν ηλεκτροπληξία ή έγκαυμα από υψηλό ρεύμα βραχυκυκλώματος. Λαμβάνετε τις κατάλληλες προφυλάξεις.
- Απαιτείται σωστή διάθεση των συσσωρευτών. Δείτε τους τοπικούς κανονισμούς που αφορούν τις απαιτήσεις διάθεσής τους.
- Ποτέ μην πετάτε τους συσσωρευτές στη φωτιά, γιατί μπορεί να εκραγούν.

Avvisi di sicurezza

IMPORTANTI ISTRUZIONI DI SICUREZZA CONSERVARE QUESTE ISTRUZIONI QUESTO MANUALE CONTIENE IMPORTANTI ISTRUZIONI DI SICUREZZA

PERICOLO



La TENSIONE contenuta in questo gruppo statico di continuità è LETALE. Tutte le operazioni di riparazione e di manutenzione devono essere effettuate ESCLUSIVAMENTE DA PERSONALE TECNICO AUTORIZZATO. All'interno del gruppo statico di continuità NON vi sono PARTI RIPARABILI DALL'UTENTE.

AVVERTENZA



- Questo gruppo statico di continuità contiene una fonte di energia autonoma (le batterie). Le prese di uscita possono condurre tensione energizzata quando il gruppo statico di continuità non è collegato con una fonte di alimentazione a corrente alternata.
- Non rimuovere nè scollegare il cavo di ingresso quando il gruppo statico di continuità è acceso poichè in tal modo si disattiverebbe il collegamento a terra di sicurezza del gruppo statico di continuità e dell'apparecchiatura ad esso collegata.

- Per ridurre il rischio di incendio o di scossa elettrica, installare il gruppo statico di continuità in un ambiente interno a temperatura ed umidità controllata, privo di agenti contaminanti conduttivi. La temperatura ambiente non deve superare i 40°C. Non utilizzare l'unità in prossimità di acqua o in presenza di umidità eccessiva (95% max).
- Per conformità con gli standard internazionali e con le norme in merito al cablaggio, tutta l'apparecchiatura collegata con l'uscita del gruppo statico di continuità non deve avere una corrente di dispersione di terra superiore a 1,5 milliampere.

ATTENZIONE



- Le batterie possono presentare rischio di scossa elettrica o di ustioni provocate da alta corrente dovuta a corto circuito. Osservare le apposite istruzioni.
- Le batterie devono essere smaltite in modo corretto. Per i requisiti di smaltimento fare riferimento alle disposizioni locali.
- Non gettare mai le batterie nel fuoco poichè potrebbero esplodere se esposte alle fiamme.

Viktig Sikkerhetsinformasjon

FARLIG



Denne UPS'en inneholder LIVSFARLIGE SPENNINGER. All reparasjon og service må kun utføres av AUTORISERT SERVICEPERSONALE. BRUKERE KAN IKKE UTFØRE SERVICE PÅ NOEN AV DELENE i UPS'en.

FARLIG



- Denne UPS'en har en egen energikilde (batterier). Stikkontaktene kan være strømførende selv om UPS'en ikke er tilsluttet en vekselstrømforsyning.
- Strømforsyningskabelen må ikke fjernes eller trekkes ut når UPS'en er på, slik at ikke sikkerhetsjordingen fjernes fra UPS'en og det utstyret som er forbundet med den.
- For å redusere fare for brann eller elektriske støt, bør denne UPS'en installeres i et innendørs miljø med kontrollert temperatur og luftfuktighet som er fritt for ledende, forurensende stoffer. Romtemperaturen må ikke overskride 40°C. Den må ikke brukes i nærheten av vann eller ved meget høy luftfuktighet (95% maks.).

- Alt utstyr som er forbundet med utgangen av denne UPS'en må ikke ha en sterkere total lekkasjestrøm enn 1,5 milliampere for å være i overensstemmelse med internasjonale standarder og forkablingsbestemmelser.

FORSIKTIG



- Batterier kan forårsake elektriske støt eller forbrenning på grunn av høy kortslutningsstrøm. Følg instruksene.
- Batterier må fjernes på korrekt måte. Se lokale forskrifter vedrørende krav om fjerning av batterier.
- Kast aldri batterier i flammer, da de kan eksplodere, hvis de utsettes for åpen ild.

Regulamentos de Segurança

INSTRUÇÕES DE SEGURANÇA IMPORTANTES GUARDE ESTAS INSTRUÇÕES ESTE MANUAL CONTÉM INSTRUÇÕES DE SEGURANÇA IMPORTANTES

CUIDADO



A UPS contém VOLTAGEM MORTAL. Todos os reparos e assistência técnica devem ser executados SOMENTE POR PESSOAL DA ASSISTÊNCIA TÉCNICA AUTORIZADO. Não há nenhuma PEÇA QUE POSSA SER REPARADA PELO USUÁRIO dentro da UPS.

ADVERTÊNCIA



- Esta UPS contém sua própria fonte de energia (baterias). Os receptáculos de saída podem conter voltagem ativa quando a UPS não se encontra conectada a uma fonte de alimentação de corrente alternada.
- Não remova ou desconecte o cabo de entrada quando a UPS estiver ligada. Isto removerá o aterramento de segurança da UPS e do equipamento conectado.
- Para reduzir o risco de incêndios ou choques elétricos, instale a UPS em ambiente interno com temperatura e umidade controladas e livres de contaminadores condutíveis. A temperatura ambiente não deve exceder 40°C. Não opere próximo a água ou em umidade excessiva (máx: 95%).
- Para estar de acordo com os padrões internacionais e os regulamentos de fiação, o equipamento total conectado à saída desta UPS não deve ter uma corrente de fuga à terra maior que 1,5 miliampères.



PERIGO

- As baterias podem apresentar o risco de choque elétrico, ou queimaduras provenientes de alta corrente de curto-circuito. Observe as instruções adequadas.
- Siga as instruções apropriadas ao desfazer-se das baterias. Consulte os códigos do local para maiores informações sobre os regulamentos de descarte de produtos.
- Nunca jogue as baterias no fogo, porque há risco de explosão.

Предупреждения по мерам безопасности

ВАЖНЫЕ УКАЗАНИЯ ПО МЕРАМ БЕЗОПАСНОСТИ СОХРАНИТЕ ЭТИ УКАЗАНИЯ ДАННОЕ РУКОВОДСТВО СОДЕРЖИТ ВАЖНЫЕ УКАЗАНИЯ ПО МЕРАМ БЕЗОПАСНОСТИ



ОПАСНО

В данном ИБП имеются СМЕРТЕЛЬНО ОПАСНЫЕ НАПРЯЖЕНИЯ. Все работы по ремонту и обслуживанию должны выполняться ТОЛЬКО УПОЛНОМОЧЕННЫМ ОБСЛУЖИВАЮЩИМ ПЕРСОНАЛОМ. Внутри ИБП нет узлов, ОБСЛУЖИВАЕМЫХ ПОЛЬЗОВАТЕЛЕМ.



ПРЕДУПРЕЖДЕНИЕ

- Данный ИБП содержит собственные источники энергии (аккумуляторы). На выходных розетках может иметься напряжение, даже когда ИБП не подключен к сети переменного тока.
- Не отсоединяйте сетевой шнур и не извлекайте его вилку из розетки при включенном ИБП. При этом защитное заземление отключается от ИБП и от оборудования, подключенного к ИБП.
- Для снижения опасности пожара или поражения электрическим током устанавливайте ИБП в закрытом помещении с контролируемой температурой и влажностью, в котором отсутствуют проводящие загрязняющие вещества. Температура окружающего воздуха не должна превышать 40°C. Не эксплуатируйте устройство около воды или в местах с повышенной влажностью (макс. 95%).

- Для обеспечения соблюдения требований международных стандартов и требований к разводке электрических цепей, суммарная величина тока утечки на землю всего оборудования, подключенного к выходу ИБП, не должна превышать 1,5 миллиампера.

ОСТОРОЖНО



- Аккумуляторы могут вызвать опасность поражения электрическим током или ожога от тока короткого замыкания. Соблюдайте соответствующие меры предосторожности.
- Необходимо соблюдать правила утилизации аккумуляторов. Обратитесь к местным нормативным актам за информацией о требованиях к утилизации.
- Никогда не бросайте аккумуляторы в огонь. Аккумуляторы могут взорваться под воздействием огня.

Advertencias de Seguridad

INSTRUCCIONES DE SEGURIDAD IMPORTANTES GUARDE ESTAS INSTRUCCIONES ESTE MANUAL CONTIENE INSTRUCCIONES DE SEGURIDAD IMPORTANTES

PELIGRO



Este SIE contiene VOLTAJES MORTALES. Todas las reparaciones y el servicio técnico deben ser efectuados SOLAMENTE POR PERSONAL DE SERVICIO TÉCNICO AUTORIZADO. No hay NINGUNA PARTE QUE EL USUARIO PUEDA REPARAR dentro del SIE.

ADVERTENCIA



- Este SIE contiene su propia fuente de energía (las baterías). Los receptáculos de salida pueden transmitir corriente eléctrica aun cuando el SIE no esté conectado a un suministro de corriente alterna (c.a.).
- No retire o desenchufe el cable de entrada mientras el SIE se encuentre encendido. Esto suprime la descarga a tierra de seguridad del SIE y de los equipos conectados al SIE.

- Para reducir el riesgo de incendio o de choque eléctrico, instale este SIE en un lugar cubierto, con temperatura y humedad controladas, libre de contaminantes conductores. La temperatura ambiente no debe exceder los 40°C. No trabaje cerca del agua o con humedad excesiva (95% máximo).
- Para cumplir con los estándares internacionales y las normas de instalación, la totalidad de los equipos conectados a la salida de este SIE no debe tener una intensidad de pérdida a tierra superior a los 1,5 miliamperios.

PRECAUCIÓN



- Las baterías pueden presentar un riesgo de descargas eléctricas o de quemaduras debido a la alta corriente de cortocircuito. Preste atención a las instrucciones correspondientes.
- Es necesario desechar las baterías de un modo adecuado. Consulte las normas locales para conocer los requisitos pertinentes.
- Nunca deseche las baterías en el fuego. Las baterías pueden explotar si se las expone a la llama.

Säkerhetsföreskrifter

VIKTIGA SÄKERHETSFÖRESKRIFTER SPARA DESSA FÖRESKRIFTER DENNA BRUKSANVISNING INNEHÅLLER VIKTIGA SÄKERHETSFÖRESKRIFTER

FARA



Denna UPS-enhet innehåller LIVSFARLIG SPÄNNING. ENDAST AUKTORISERAD SERVICEPERSONAL får utföra reparationer eller service. Det finns inga delar som ANVÄNDAREN KAN UTFÖRA SERVICE PÅ inuti UPS-enheten.

VARNING



- Denna UPS-enhet har en egen energikälla (batterier). De utgående kontakterna kan vara strömförande när UPS-enheten inte är ansluten till en växelströmkälla.
- Ta aldrig bort nätsladden när UPS-enheten är påslagen. Detta tar bort skyddsjordningen från både UPS-enheten och den anslutna utrustningen.

- Minska risken för brand eller elektriska stötar genom att installera denna UPS-enhet inomhus, där temperatur och luftfuktighet är kontrollerade och där inga ledande föroreningar förekommer. Omgivande temperatur får ej överstiga 40°C. Använd inte utrustningen nära vatten eller vid hög luftfuktighet (max 95 %).
 - För att överensstämna med internationell standard och installationsföreskrifter får inte den totala utrustning som anslutits till uttagen på denna UPS-enhet ha läcksström som överstiger 1,5 milliamperere.
-



VIKTIGT

- Batterierna kan ge elektriska stötar eller brännskador från hög kortslutningsström. Följ tillämpliga anvisningar.
 - Batterierna måste avyttras enligt anvisningarna i lokal lagstiftning.
 - Använda batterier får aldrig brännas upp. De kan explodera.
-



CHAPTER 3

UPS STARTUP

This section provides step-by-step instructions for starting the Powerware FERRUPS UPS. Follow these procedures closely to avoid potential damage to your equipment or the UPS and to protect yourself and others from hazardous operating conditions.

Startup for the FE and QFE 500 VA–3.1 kVA UPS

To start the FE and QFE 500 VA–3.1 kVA UPS, use the following steps:

1. Confirm the equipment to be protected by the UPS is powered off.
2. **For FE Plug-Receptacle UPSs:** Plug the UPS power cord into a power outlet.



NOTE If the plug does not match your receptacle outlet, ask your electrician to install the proper outlet.

For QFE Plug-Receptacle UPSs: Disconnect the power cord from the computer or other equipment to be protected by the UPS and plug it into the UPS. Plug the other end of the power cord into a power outlet.



NOTE Do not use the cord supplied with the UPS; this cord is for plugging the equipment into the UPS output receptacles.

NOTE If the plug does not match your receptacle outlet, ask your electrician to install the proper outlet.

NOTE If you need to order a UPS power cord, please call your service representative.

For Hardwired UPSs: Confirm that an electrician has completed and tested the connection to the proper power source and connected your protected equipment according to the *Powerware FERRUPS FE/QFE UPS (500 VA–18 kVA) Installation Guide*. Turn the AC line disconnect switch to the ON position.

- The AC LINE indicator illuminates (see Figure 2).



NOTE The AC LINE indicator does not illuminate for FE models with serial numbers 25000 and greater until the UPS ON/OFF switch is turned to the ON position.

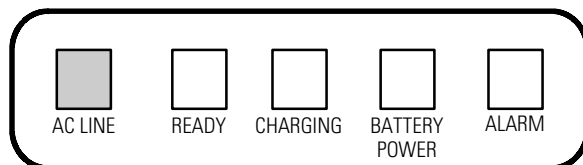

Figure 2. Front Panel Indicators

- If you have an external battery cabinet with a DC switch, turn the switch to the ON position.
- Turn the UPS ON/OFF switch to the ON position. After a short startup test, the READY indicator flashes for a few seconds and then remains illuminated. The UPS is ready to supply output power.



NOTE The UPS and external battery cabinets are shipped with the batteries charged. However, batteries may lose some of the charge during shipping and storage. You can use the UPS immediately after unpacking, but it may not provide the full-rated backup time during a power failure. Upon initial startup, the UPS may need to operate for 24 hours before the battery is fully charged and full battery-backup time is available. If the CHARGING indicator is illuminated, operate the UPS for 24 hours to fully charge the battery.

- For Plug-Receptacle UPSs:** Plug the equipment to be protected into the UPS output receptacles.



NOTE For QFE models, use the supplied UPS cord to connect your equipment to the UPS output receptacles.

For Hardwired UPSs: Turn the bypass switch to the UPS position.

- Turn on the equipment that is connected to the UPS.

Startup for the FE and QFE 4.3–18 kVA UPS

To start the FE and QFE 4.3–18 kVA UPS, use the following steps:

1. Confirm the equipment to be protected by the UPS is powered off.
2. **For Plug-Receptacle UPSs:** Verify that the AC input power is off at the service panel. Plug the UPS power cord into a power outlet.



NOTE If the plug does not match your receptacle outlet, ask your electrician to install the proper outlet.

For Hardwired UPSs: Confirm that an electrician has completed and tested the connection to the proper power source and connected your protected equipment according to the *Powerware FERRUPS FE/QFE UPS (500 VA–18 kVA) Installation Guide*. Confirm that your AC line disconnect switch and the UPS ON/OFF switch are both in the OFF position.

3. If your UPS has a DC switch, turn on the switch according to the UPS model:

4.3–7 kVA: If you have an external battery cabinet(s) with a DC switch, turn the switch to the ON position.

If you do not have an external battery cabinet(s): unlock the UPS front cover panel using the FERRUPS key and remove the front cover panel. Locate the DC switch behind the UPS front cover panel. If there is a precharge button next to the switch, press it for a few seconds. Turn the DC switch to the ON position and reinstall the UPS front cover panel.

10–18 kVA: If you have an external battery cabinet(s) with a DC switch, turn the switch to the ON position.

4. **Starting the UPS on battery power:** Use the key to turn the ON/OFF switch to the ON position. After a brief self-check, the BATTERY POWER and READY indicators illuminate. The UPS beeps every 20 seconds, indicating the UPS is running on battery power. The control panel scrolls this display:

```
FERRUPS
Mode:      Auto
Charger:   Off
Beeper:    Enabled
```



NOTE If the ALARM indicator is on, read the alarm message on the control panel display, turn the ON/OFF and DC switches to the OFF position, and call your service representative.

For Plug-Receptacle UPSs: Turn the AC input power on at the service panel. The AC LINE indicator illuminates. After a few seconds, the UPS switches from battery power to AC input power. The BATTERY POWER indicator turns off.

For Hardwired UPSs: Turn the AC line disconnect switch to the ON position. The AC LINE indicator illuminates. After a few seconds, the UPS switches from battery power to AC input power. The BATTERY POWER indicator turns off. Now, turn the UPS bypass switch (either on the back of the UPS or mounted nearby) to the UPS position.



NOTE The UPS and external battery cabinets are shipped with the batteries charged. However, batteries may lose some of the charge during shipping and storage. You can use the UPS immediately after unpacking, but it may not provide the full-rated backup time during a power failure. Upon initial startup, the UPS may need to operate for 24 hours before the battery is fully charged and full battery-backup time is available. If the CHARGING indicator is illuminated, operate the UPS for 24 hours to fully charge the battery.

5. **For Plug-Receptacle UPSs:** Plug the equipment you want to protect into the UPS receptacles and turn on the equipment. If the ALARM indicator illuminates, see “Alarms” on page 59.

For Hardwired UPSs: Turn on the equipment connected to the UPS. If the ALARM indicator illuminates, see “Alarms” on page 59.

6. Set the time and date using the control panel.



NOTE The correct time and date for is needed for the UPS alarm and inverter logs. Reset the time and date whenever the UPS has been shut down.

Time is parameter 0; see “Parameters” on page 32 for more information. To set the time, follow these steps:

Press this key:	Display shows:
[DISPLAY]	Display:
[0]	Display: 0
[ENTER]	00 Time: 11:30:20
[PROGRAM]	00 Pgm:

The date is parameter 10. To display the date, follow these steps:

Press this key:	Display shows:
[DISPLAY]	Display:
[1][0]	Display: 10
[ENTER]	10 Date: 01/01/96
[PROGRAM]	10 Pgm:

7. If your FERRUPS UPS is configured to use an external battery cabinet, you must program the battery capacity in ampere-hour (Ah) for the total number of battery packs used in the UPS. If you purchased one of the FERRUPS battery pack options available from Powerware, select the Ah value from Table 1.

Before programming the battery Ah, enter the user password following the instructions in “Entering Passwords” on page 28. To change the battery Ah, parameter 69 (Batt Ah), follow these steps:

Press this key:	Display shows:
[DISPLAY] [6] [9] [ENTER]	69 Batt AH [Default]
[PROGRAM]	69 Pgm:
[Ah Value from Table 1]	69 Pgm: [xxx]
[ENTER]	69 Pgm: [new value]

where xxx is the Battery Ah value from Table 1.

Table 1. External Battery Pack Ah Values

Battery Pack	Battery Ah	Battery Pack	Battery Ah
1ME	100	1FE	100
2ME	150	2FE	150
3ME	200	3FE	200
4ME	225	4FE	225
5ME	300	5FE	300
6ME	400	6FE	400
7ME	600	7FE	600
8ME	75	8FE	75
9ME	100	9FE	100
10ME	150	10FE	150
11ME	200	11FE	200
12ME	225	12FE	225
13ME	300	13FE	300
14ME	400	14FE	400
15ME	600	15FE	600
21ME	75	16FE	100
24ME	150	17FE	150
25ME	200	18FE	200
EBPS10	33	19FE	225
EBPS12.5	75	20FE	300
EBPS18	75	21FE	400
		22FE	600

Rear Panels

This section shows the rear panels of the FERRUPS models.

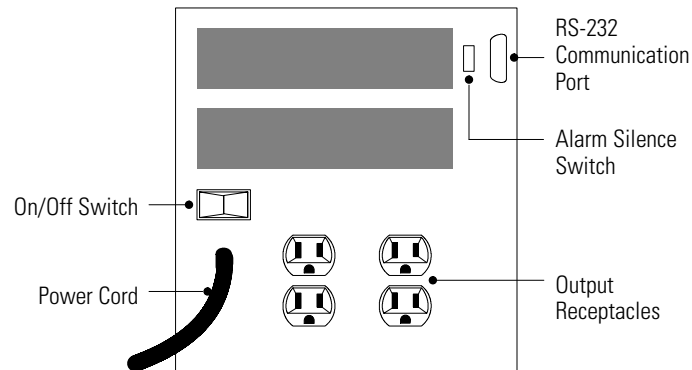

Figure 3. FERRUPS 500–850 VA UPS Rear Panel

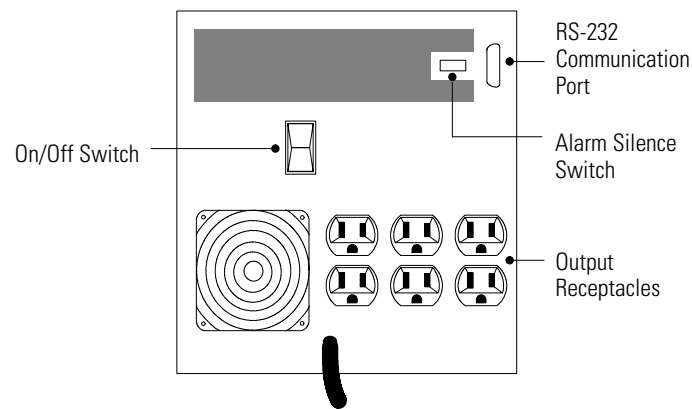

Figure 4. FERRUPS 1.15–1.4 kVA Rear Panel

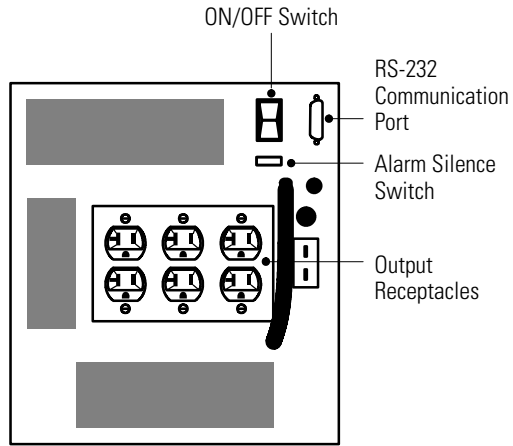

Figure 5. FERRUPS 1.8–3.1 kVA Rear Panel

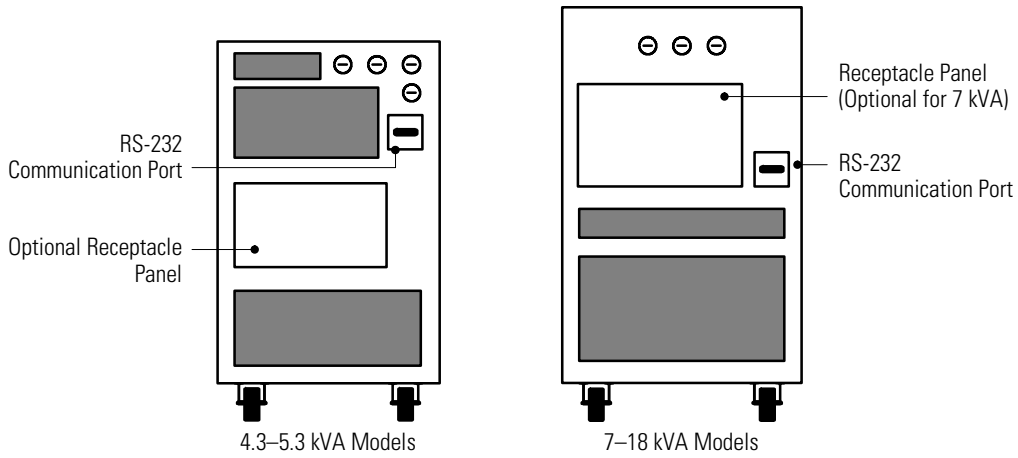

Figure 6. FERRUPS 4.3–18 kVA Rear Panels



CHAPTER 4

OPERATION

This section describes:

- The UPS front panel indicators
- Using the control panel
- Automatic system testing
- Parameters
- Shutting down the UPS

Front Panel Indicators

The UPS front panel indicators indicate how the UPS is operating and also alert you of potential power problems. Figure 7 shows the UPS front panel indicators. Table 2 explains the status of each indicator.

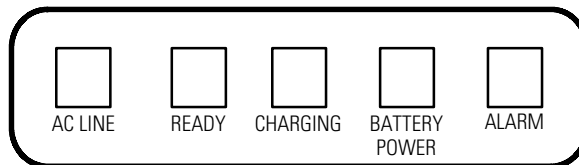

Figure 7. Front Panel Indicators

Table 2. Indicator Status

Indicator	Status	Explanation
AC LINE	On	The UPS is getting power from the AC input power source. NOTE The AC LINE indicator does not illuminate for FE models with serial numbers 25000 and greater until the UPS ON/OFF switch is turned to the ON position.
	Off	<ul style="list-style-type: none"> • The UPS is not getting input power. • There is a power outage. • The AC input breaker is tripped. • The UPS is unplugged. • For FE models with serial numbers 25000 and greater, the ON/OFF switch is not in the ON position.
	Flashing	Not applicable.
READY	On	The UPS is ready to provide battery backup power when needed.
	Off	The UPS cannot provide battery backup power because: <ul style="list-style-type: none"> • It is in the Line Condition mode or the Off mode (see “Using the Control Panel” on page 27). • The batteries may be discharged. • It may be running on battery power.
	Flashing	The UPS is testing the batteries as part of the automatic system test (see “Automatic System Test” on page 31); or, you have started a timed shutdown (see Table 8 on page 44).
CHARGING	On	The UPS is charging its batteries.
	Off	The battery charger is off; batteries are at full charge.
	Flashing	Not applicable.
BATTERY POWER	On	The UPS is providing power from its batteries; it is in the Inverter On mode.
	Off	The UPS is providing conditioned power from the AC input power source, or the UPS is off.
	Flashing	The UPS is testing the inverter as part of the automatic system test (see “Automatic System Test” on page 31).
ALARM	On	The UPS is warning you that an alarm exists. If you have not silenced the alarm, the beep sequence identifies the problem (see “Alarms” on page 59.) If you have a control panel, an alarm message appears on its display.
	Off	No alarm exists.
	Flashing	Not applicable.

Using the Control Panel

The control panel comes with all FE/QFE 4.3–18 kVA models. If you have an FE/QFE 500 VA–3.1 kVA, you may have ordered the control panel as an option (refer to TIP 407 to connect the control panel).

The control panel is attached to the front of the UPS with a 6-ft (1.8m) cable, providing hand-held operation. The control panel's READY, BATTERY POWER, and ALARM indicators work like the READY, BATTERY POWER, and ALARM indicators on the front of the UPS (see "Front Panel Indicators" on page 25.)

You can use the control panel to change UPS system modes and display and change parameters. You can also lock the control panel and change some of its features. If you press the wrong key at any time, press [CLEAR] and then the correct key. The control panel makes a clicking noise each time you press a key.

Changing Operating Modes

There are four UPS operating modes:

- Auto
- Inverter On
- Line Condition
- Off

The FERRUPS UPS selects the appropriate operating mode automatically; however, there may be times when you need to set the operating mode manually from the control panel. Notice that names of the operating modes appear in red on the bottom of keys 1–4.

Table 3. Operating Modes

Operating Mode	How to Select It	What It Means
Off	Press [CTRL]-[1] [ENTER] [ENTER].	The UPS does not provide power to your equipment, but you can still use the control panel if battery power is present. The READY indicator is off.
Auto	Press [CTRL]-[2] [ENTER] [ENTER].	This is the normal operating mode. The UPS conditions AC input power and provides the conditioned power to your equipment. The UPS is ready to switch to battery power if necessary. The AC LINE and READY indicators are illuminated.
Line Condition	Press [CTRL]-[3] [ENTER] [ENTER].	The UPS is conditioning AC input power and providing the conditioned power to your equipment, but if there is a brownout or power outage, the UPS does not switch to battery power. Instead, the UPS shuts down its output until AC input power is available again. The READY indicator is off when the UPS is in this mode.
Inverter On (Battery Power)	Press [CTRL]-[4] [ENTER] [ENTER].	The UPS converts battery power to AC power for your equipment. It does not charge the batteries. The BATTERY POWER indicator is on. The UPS calculates the runtime remaining and sounds an alarm when runtime starts to get low.

Entering Passwords

Before you can change some parameter values, you must enter a password. You must also enter a password before you enter some of the commands listed on page 44.



NOTE Some parameters, such as Time, Date, and User ID, are not password-protected initially. If you change parameter 39 to "Yes," a User password is required to change these parameters, use [CTRL] keys, or use some commands. See "Parameters" on page 32 and "Entering Commands from a Terminal or Computer" on page 44 for more information.

The User Password is 377. If you need a higher password, call your service representative. To enter the User Password, follow these steps:

Press this key:	Display shows:
[CLEAR]	FERRUPS
[PROGRAM]	Password:
[3] [7] [7]	Password: 377
[ENTER]	Level: User

To clear the password, press [CLEAR] until **Password Cleared** appears on the control panel display.

Displaying and Changing Parameters

The names of the first 11 parameters appear in green on the top of the number keys. To display a parameter, press [DISPLAY], the parameter number, and [ENTER]. For example, to display parameter 0 (time), follow these steps:

Press this key:	Display shows:
[DISPLAY]	Display:
[0]	Display: 0
[ENTER]	00 Time 07:04:08

To change a parameter, display it first. Then, press [PROGRAM], enter the new value for the parameter, and press [ENTER]. For example, to change parameter 0 (time), follow these steps:

Press this key:	Display shows:
[DISPLAY] [0] [ENTER]	00 Time 07:04:08
[PROGRAM]	00 Pgm:
[9] [3] [0]	00 Pgm: 930
[ENTER]	00 Time 09:30:00

Locking and Unlocking the Control Panel

You may need to lock the control panel if you want to limit its use. When disabled the control panel does not respond to the key functions until it is enabled again. To disable the panel, press the keys shown in the following example (verify that you have the necessary code to unlock the control panel).

Press this key:	Display shows:
[CLEAR] and [ENTER] together	-Keypad Locked-

When you lock the control panel, it beeps and shows the display above for approximately two seconds. The control panel beeps and shows this display whenever you try to use the keys. The front panel indicators continue to show the UPS status, and the control panel shows UPS alarms. To enable the control panel again,

Press this key:	Display shows:
[CLEAR] and [ENTER] together	Unlock #:
[8] [2] [0] [4] [9]	Unlock #: 82049
[ENTER]	Keypad Unlocked

After approximately two seconds, the control panel shows the same display it showed before you unlocked it. If you enter the wrong unlock number, the control panel displays **-Keypad Locked-** for two seconds, and the control panel remains locked.

Using the Configuration Menu

The control panel includes a Configuration Menu that lets you adjust its baud rate and brightness, turn the beeper on or off, turn on and off the click you hear when you press keys, and control other features. The label on the back of your control panel includes more information on this menu (see Figure 8).

Remote Control Panel (RCP)
Access Instructions for Configuration Menu

Simultaneously press [CONTROL] and [PROGRAM] to enter RCP Configuration menu

At any time: Press **[ENTER]** to display/edit next menu item
 Press **[PROGRAM]** to exit menu and save changes
 Press **[CLEAR]** to exit menu without saving changes

Menu Item	Range	Notes
Baud Rate	0 - 5	0=300, 1=1200, 2=2400, 3=4800, 4=9600, 5=19200
Brightness	0 - 7	Display brightness: 0=Min, 7=Max
Beeper	0 - 1	Beeper enabled? 0=No, 1=Yes
Keyclick	0 - 1	Keyclick enabled? 0=No, 1=Yes
Repeat	0 - 1	Autorepeat of depressed key? 0=No, 1=Yes
Connect	0 - 1	Send "123DCP" at startup? 0=No, 1=Yes

Figure 8. Remote Control Panel

Automatic System Test

The UPS performs an automatic system test every seven days to test the memory, batteries, and inverter. During the system test, the BATTERY POWER and READY indicators Flash. For the results of the last system test, you can display parameter 26 (see page 35).

Logic Test

First, the UPS checks its memory. If it finds a problem, the UPS sounds alarm O, Memory Check (– – –). See “Alarms” on page 59.

Inverter Test

The inverter converts DC battery power into the AC power your equipment uses. During the inverter test, the UPS pulses its inverter to see if it delivers the proper amount of current. If not, the UPS sounds alarm N, Check Inverter (– •). See “Alarms” on page 59.

Although it is testing the inverter, the UPS is not in Inverter On mode. The UPS continues to condition input power and is ready to provide battery power if there is a power outage. The BATTERY POWER indicator flashes during this part of the test.



NOTE FE models with serial numbers 25000 and greater do not perform an individual inverter test.

Battery Test

The UPS also checks its batteries to verify that they can support your equipment for the minimum specified runtime. If not, the UPS sounds alarm M, Check Battery (– –). See “Alarms” on page 59. The READY indicator flashes during this part of the test.

Parameters

Table 4 shows the first 26 parameters. You can view or reset the parameters using the control panel or a terminal or computer.

If you plan to view or change parameters from the control panel, see “Using the Control Panel” on page 27 for instructions.

If you plan to view or change parameters from a terminal or computer that you have connected to the RS-232 port, see “Entering Commands from a Terminal or Computer” on page 44. When you use commands to display or change parameters, identify the parameter with either its number or name (see Table 4). If you use the name, you can enter the entire parameter name or just the short form; you can also abbreviate the parameter name as long as your abbreviation includes the letters in the short form.

Although you do not need a password to view any of the first 26 parameters, all of them require a password to change (see the password column in Table 4.) See “Entering Passwords” on page 28 or “Entering Commands from a Terminal or Computer” on page 44 for password information.



NOTE All changeable parameters except 0 (Time), 10 (Date), and 15 (Unit ID) are set at the factory. Only qualified technicians using the proper metering equipment should change other parameters. Improper calibration may cause the FERRUPS UPS to malfunction. Call your service representative before you attempt to change any parameters except 0, 10, and 15.

Table 4. Parameters

Parameter Number	Sample Display	Password	Parameter Name (Short Form)	Explanation
0	00 Time 07:04:00	None	time (t)	System Time. The UPS uses this time to record alarms and inverter runs. When the DC power has been off and you restart the UPS, the time shown is the last recorded time before shutdown. Reset time when DC power has been off.
1	01 V In 120.7	Service	acvoltsin (vi)	The input voltage the UPS is receiving. When this value drops below the brownout voltage, the UPS switches to inverter.
2	02 V Out 120.7	Service	acvoltsout (vo)	The voltage the UPS is providing to your equipment.

Parameter Number	Sample Display	Password	Parameter Name (Short Form)	Explanation
3	03 --Reserved--		Reserved	
4	04 I Out 3.1	Service	acampsioout (o)	The current your equipment is drawing from the UPS.
5	05 VA Out 374	Change Not Allowed	vaout (va)	Volt-Amps Out. The total "apparent power" your equipment is drawing from the UPS. This value is based on parameter 2 multiplied by parameter 4, and should be less than or equal to the VA or kVA rating of the UPS. See VA Limit, parameter 19.
6	06 I Batt 0.0	Service	ibatt (ib)	Battery Current. When the UPS is running on AC input, this is the charging current inA. When the UPS runs on battery power (inverter), this is the amount of current (inA) the batteries are supplying to the UPS.
7	07 V Batt 48.51	Service	vbatt (vb)	Battery Volts. The present battery voltage. The UPS sounds an alarm if this value is too low.
8	08 Freq 60.43 Hz	Change Not Allowed	frequency (f)	In normal operation, this is the frequency of power the UPS is receiving from the AC input source. If this value falls outside preset limits, the UPS goes to battery power. When the UPS is running on battery power, this is the frequency the UPS is supplying to your equipment.
9	09 RunTime 12m	Change Not Allowed	runtime (rt)	Estimated Runtime Remaining. The amount of time the UPS continues to support your equipment when the UPS is running on battery power. The UPS sounds an alarm when this value falls below a preset limit.
10	10 Date 06/01/93	None	date (d)	System Date. The UPS uses this date to record alarms and inverter runs. The date must be reset when you restart the UPS after DC power is turned off.
11 or [DISPLAY] [1] [1] [ENTER]	11 Amb Temp 23c	Change Not Allowed	ambtemp (at)	The temperature (in Celsius) inside the UPS. The UPS sounds an alarm and shuts down if this value is too high.
12	12 SinkTemp 26c	Change Not Allowed	heatsinktemp (st)	The temperature of the heatsink. The UPS sounds an alarm if this value is too high.
13	13 --Reserved--		Reserved	

Parameter Number	Sample Display	Password	Parameter Name (Short Form)	Explanation
14	14 XfmrTemp 28c	Change Not Allowed	xfmrtemp (xt)	The temperature of the transformer. The UPS sounds an alarm and shuts down if this value is too high. NOTE This parameter is only active on some models; for other models, the display always shows -63c.
15	15 Unit ID Network #1 UPS	None (See "Entering Passwords" on page 28.)	unitident (id)	UPS ID. An identification string that can be configured for use with your network.
16	16 FullLoad% 075	Change Not Allowed	fullload (l)	Percent of Full Load. The percentage of the UPS's total capacity that is actually being used by your equipment.
17	17 Watts 374	Change Not Allowed	watts (w)	The total "real power" your equipment is drawing from the UPS.
18	18 PF 0.73 Dist	Change Not Allowed	powerfact (pf)	The power factor of your equipment; the difference in the way it draws voltage and current. Power factor is equal to Watts Out (parameter 17) divided by VA Out (parameter 5). This parameter also tells whether the power factor is leading (Lead), lagging (Lag), or distortion (Dist).
19	19 VALimit 500	Change Not Allowed	valimit (val)	The maximum volt-amps the UPS can supply to your equipment at the present power factor. The UPS sounds an alarm when VA Out (parameter 5) is higher than this value.
20	20 #PwrOut 1	Change Not Allowed	powerout (po)	The number of times there has been a loss of input power since you started the UPS.
21	21 #OvrLds 0	Change Not Allowed	overloads (ol)	The number of times the UPS has sensed an overload; that is, the number of times VA Out has been greater than VA Limit.
22	22 SysHrs 00000	Change Not Allowed	syshours (sh)	The total number of hours the UPS has been operating, regardless of mode. This number does not increase when the UPS ON/OFF switch is in the OFF position.
23	23 InvMin 0000.0	Change Not Allowed	invmin (im)	The total number of minutes the inverter has run since startup.

Parameter Number	Sample Display	Password	Parameter Name (Short Form)	Explanation
24	24 Inverter Log L 0319 2127 1215	Change Not Allowed	inverterlog (il)	A record of the date, time, duration and reason for the last 20 inverter (battery power) runs (see "Alarm and Inverter Logs" on page 62).
25	25 Alarm Log A 0319 2127 1215	Change Not Allowed	alarmlog (al)	A record of the date, time, duration and reason for the last 20 alarms (see "Alarm and Inverter Logs" on page 62).
26	26 Test Results (See explanation.)	Change Not Allowed	testresults (tr)	This parameter records the results of the last system test. The parameter display includes the time and date of the test and the results of each part of the system test (see "Automatic System Test" on page 31.)

Additional Parameters The microprocessor in the UPS keeps track of more than 100 parameters. Parameters 27 and above are alarm and operation set points, calibration factors and other settings. You usually do not need access to these parameters for normal operation of the UPS. If you need information about the full range of UPS parameters, call your service representative to ask for TIP 407 or TIP 503. TIP 407 describes communication from a control panel. TIP 503 describes communication through the RS-232 port.

UPS Shutdown

The FERRUPS UPS is designed for many years of round-the-clock operation. Usually, you do not need to shut down the UPS, even if your equipment is shut down for several days. Even when it's not powering your equipment, the UPS monitors its internal condition and keeps the Time and Date parameters current.

There are times, though, when you want to shut down the UPS, such as:

1. When you do not expect to use it for an extended period of time.
2. When it is being serviced.
3. Before you move it.
4. When it has gone into the Off mode because the batteries have been discharged during an extended outage.
5. When a system malfunction requires a UPS shutdown.

CAUTION

When AC input voltage is present, the UPS system can provide output voltage even though its batteries are disconnected. To confirm that there is no UPS output voltage, always disconnect the AC input source; if the UPS has one or more separate battery cabinets, open the DC disconnect switch on each battery cabinet or disconnect the battery cabinet from the UPS.

1. **UPSs with no bypass switch:** Turn off the protected equipment. Continue to Step 2.

If you need to use the equipment while the UPS is off, plug the equipment into standard wall outlets and restart the equipment.

UPSs with a Break-Before-Make (BBM) bypass switch (see the label on the side of the switch): Shut down the protected equipment. Turn the bypass switch to the LINE position. Continue to Step 2.

If you need to use the equipment while the UPS is off, restart the equipment. The equipment receives direct AC line instead of conditioned power from the UPS.

UPSs with a Make-Before-Break (MBB) bypass switch (see the label on the side of the switch): Verify that the AC LINE indicator is on, the BATTERY POWER indicator is off, and the UPS is providing output. If all three of these conditions are present, turn the bypass switch to the LINE position. Your equipment receives direct AC line instead of conditioned power from the UPS. Continue to Step 2.

If all three of these conditions are not present, follow Steps 2–4 before you turn the bypass switch to the LINE position. This causes a break in power to your equipment between shutting down the UPS and turning the bypass switch to the LINE position.

CAUTION

Equipment can be damaged if you change the switch position when line is applied and the UPS is off or on battery! Refer to TIP 410.

2. Turn the UPS ON/OFF switch to the OFF position.
3. If the UPS is plugged in, unplug it. For hardwired models, turn the AC line disconnect switch to the OFF position.

4. **500 VA–3.1 kVA:** If you have a battery cabinet that has a DC switch on the front, turn the switch to the OFF position. If your battery cabinet does not have a DC switch on the front, unplug the connector between the battery cabinet(s) and the UPS; be sure to reconnect this connector before you start the UPS again.
4.3–18 kVA: Unlock the lock in the center of the front panel and remove the panel. If there is a DC switch behind the panel, turn it to the OFF position. Reattach the panel to the UPS. If your UPS has separate battery cabinets, turn the DC switch at each battery cabinet to the OFF position.
5. **If the UPS is turned off for an extended period of time,** recharge the batteries every 90–120 days to prevent battery damage. To restart the UPS, see “Startup” on page 17.

Extended Power Outages

If the power is out for an extended time, the UPS continues to provide power for your equipment until it gets near the end of its runtime. You can check the remaining battery runtime by reading parameter 9 (see page 33.) At a preset number of minutes before the end of the runtime (factory-default setting is five minutes), the UPS sounds a Low Runtime alarm (–••). Shut down your equipment and turn off the UPS to conserve the remaining battery power (see “UPS Shutdown” on page 35). When AC input power returns, turn on the UPS to recharge the batteries.

If your UPS shuts itself down because its battery voltage is too low, shut down the UPS until the AC input power returns (see “UPS Shutdown” on page 35).



CHAPTER 5

COMMUNICATION

The FERRUPS UPS is capable of full-duplex communication and can communicate with a computer, a Local Area Network (LAN), or a multi-user computer system. If your system comes with UPS monitoring and automatic shutdown software, the FERRUPS UPS can communicate with that software. If your system does not have software, you can use the CheckUPS II Power Management Software included on the Powerware Software Suite CD-ROM.

If you do not plan to use CheckUPS II software or other UPS monitoring software, you can still set up RS-232 communication with the UPS and use commands and parameters to control UPS operation.

Powerware Software Suite

Each UPS ships with the Powerware Software Suite CD-ROM and a communication cable. To begin installing CheckUPS® II software, refer to the instructions accompanying the Powerware Software Suite CD-ROM.

CheckUPS II software uses an RS-232 serial link to communicate with the UPS, and (using Microsoft® Windows®) it provides you with up-to-date graphics of UPS power and system data and power flow. It also gives you a complete record of critical power events and notifies you of important UPS or power information. If there is a power outage and the UPS system battery power becomes low, CheckUPS II software can automatically shut down your computer system to protect your data before the UPS Low Battery shutdown occurs.



NOTE You can download the latest software version from www.powerware.com.

Communication Port

The communication port cable pins are identified in Figure 9 and the pin functions are described in Table 5.

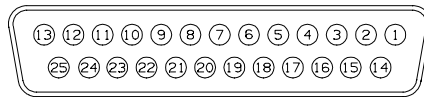

Figure 9. Communication Port

Table 5. Communication Port Pin Functions

Pin	Function	Function
2	Transmit Data (in)	
3	Receive Data (out)	
4	Request to Send	To enable hardware handshaking on these pins, call your service representative.
5	Clear to Send	
6	+12V Level (0.01A) when the UPS is operating	
7	Signal Ground	
11	Contact opens when on inverter	These relay contacts are rated at 25 Vac/Vdc and 250 mA (see "Remote Monitoring" on page 47). NOTE FE 500 VA–3.1 kVA models with serial numbers 25000 and greater have equivalently rated DC solid state switches.
12	Contact closes when on inverter	
13	Common Inverter Signal Contact	
14	+12V, 0.5A (500 VA–3.1 kVA) or 0.3A (4.3–18 kVA) Do not use for setting logic levels.	
18	+12V Level (0.01A) when UPS is operating	
20	AS/400 Option	
21	Remote Shutdown	
23	Contact closes on alarm	These relay contacts are rated at 25 Vac/Vdc and 250 mA (see "Remote Monitoring" on page 47). Pins 23 and 25 change status when the UPS is turned off.
24	Common Alarm Signal Contact	
25	Contact opens on alarm	NOTE FE 500 VA–3.1 kVA models with serial numbers 25000 and greater have equivalently rated DC solid state switches.

NOTE Pins 2–5 and 7 are for RS-232 communication, Pins 11–13 and 23–25 are for remote monitoring, and Pin 21 (used with 6 or 18) is for remote shutdown. The following sections describe how to take advantage of these features. Pin 20 is for option use only.

Connecting a Terminal or Computer to the RS-232 Port



CAUTION

Do not make connections to the RS-232 communication port if the UPS is connected to a positive ground battery system. The RS-232 ground must be isolated or equipment damage will result. For help, contact your service representative.

If you are connecting a terminal to the RS-232 port, the terminal must be capable of serial communication.

If you are connecting a computer, the computer must be running terminal emulation software (such as HyperTerminal®). Most modem software packages can emulate a terminal; if you do not have a terminal emulation program, please contact your service representative for more information.

1. To connect the FERRUPS UPS DB-25S (female) RS-232 port to your terminal or computer, you need a cable designed specifically for this purpose. (See Figure 10 and Figure 11.) Powerware offers cables for computers or terminals using 25-pin or 9-pin serial ports; call your service representative to order one of these cables. If you would like to build your own cable, follow these requirements:
 - Use a high-quality, shielded cable.
 - **Do not use a standard 25-conductor straight-through cable;** only include straight-through connections for the pins shown in Figure 10 and Figure 11.

For RS-232 communication, use Pins 2 (transmit data), 3 (receive data), and 7 (signal ground). For hardware handshaking (request to send on Pin 4 and clear to send on Pin 5), contact your service representative. No other pins should be connected from the UPS RS-232 port to your terminal or computer.

For more information on pin connections and the function of the non-serial pins on the RS-232 port, see Table 5 on page 40 and “Remote Monitoring” and “Remote Shutdown” on page 47.



NOTE To connect a modem, see TIP 503.

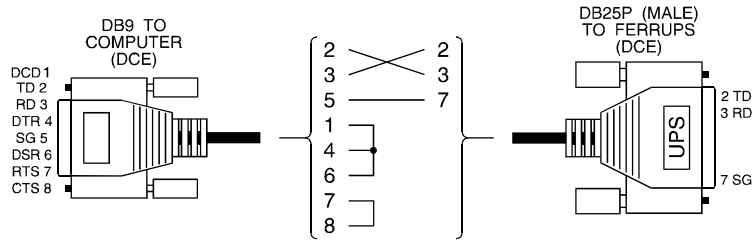

Figure 10. DB-9 to UPS Pinout

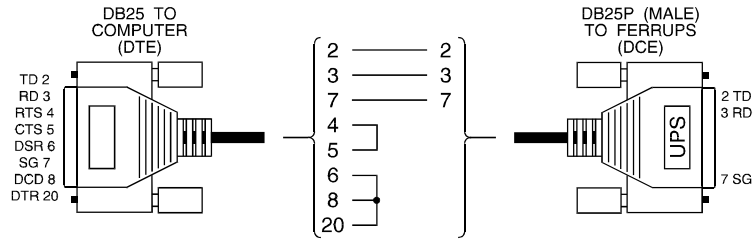

Figure 11. DB-25 to UPS Pinout

2. Connect the cable from the RS-232 port on the back of the UPS to the serial port on your terminal or computer.
3. Your terminal or computer should be set to: 1200 baud, 8 bits, No parity, 1 stop bit, and full duplex.

The terminal or terminal emulation software should also be set to full duplex. If you are using a terminal, note that the FERRUPS UPS supports the Televideo® 900 series, ADM3A and WYSE® 50 emulation.

Table 6 shows the standard settings at the UPS DB-25S port and the settings that can be adjusted. Call your service representative if you need to adjust any of the settings.

Table 6. DB-25 Port Settings

Specification	Standard Setting	Adjustable to
Connector	25 pin D (female) wired as DCE.	
Format	ASCII, 8 bits, 1 stop bit. Most significant bit set to 0.	Standard setting or 7/8 bits, 1/2 stop
Baud Rate	1200	50–38400
Parity	None	Odd, Even, or None
Duplex	Full	Full or Half

4. Turn your terminal on or run your terminal emulation software. Then press [ENTER] on your keyboard; a prompt appears on the screen. The prompt varies depending on your current password level:

=> Normal prompt

User=> User Password has been entered

5. Press [ENTER] on your keyboard a few times to verify that the UPS responds.
6. To control or monitor the UPS, simply type the desired command and press [ENTER].

Table 7 shows what keystrokes to use as you type commands or view displays. See Table 8 for more information on UPS commands.

Table 7. Keystroke Commands

Action	Key Sequence
Delete last character typed.	[BACKSPACE] or [CTRL]-[H]
Delete line.	[CTRL]-[X]
Pause displays that take more than one screen.	[CTRL]-[S]
Resume scrolling. (Turn Pause off.)	[CTRL]-[Q]

Entering Commands from a Terminal or Computer

To monitor or control the FERRUPS UPS from a terminal or computer, simply type in one of the commands and press [ENTER] (see Table 8). Use the following command syntax:

- type the command in uppercase or lowercase
- use the entire command or the short form (you can also abbreviate the command as long as you include the letters in the short form)
- use a semicolon to separate more than one command on a line

Table 8. Commands

Command	Short Form	Password	Function
alarmshelp	ah	None	Shows a list of all possible alarm messages, the audio code and letter for each alarm and whether the alarm is active.
alarmlog	al	None	Displays Alarm Log. See “Alarm and Inverter Logs” on page 62.
alarmtest	at	None	Allows you to test the alarm function. Alarmtest sounds the User Test alarm (J). See page 61.
alarmtest cancel	at c	None	Turns the User Test alarm off.
chargemode	chm	None*	Shows the UPS battery charger mode. By entering a mode after the chargemode command, you can change the charger mode: <ul style="list-style-type: none"> • chargemode off (chm f) or chargemode disable (chm d) = charger off • chargemode on (chm o) or chargemode enable (chm e) = charger on • chargemode auto (chm a) = charger enabled if AC input voltage and battery voltage are acceptable
clearalarms	ca	None	Clears all active alarms.
clearhistory	ch	None	Clears the minimum and maximum parameter values shown when you use the extendedhistory or history commands.
clearpassword	cp	None	Clears the current password.
commands	cm	None	Displays a list of all valid commands.
contdisplay	cd	Depends on parameter password	Continuously displays the parameter that you are currently displaying. You can specify other parameters for the continuous display by entering the name or number of each parameter after the contdisplay command.
contstatus	cs	None	Continuously displays the Status information (see the status command.)

*If you change parameter 39 to “Yes,” this command requires a User password.

Command	Short Form	Password	Function
date	da	None*	Displays system time and date. To set the date, enter date [month]/[day]/[year] .
delay	dl	None	Delays next command when you enter a number after delay . Each unit represents 2.5 milliseconds, so delay 1 would cause a 2.5 millisecond delay. For a 1-second delay, enter delay 400 .
display	d	Depends on parameter password	Displays the values of one or more parameters (see Table 4 on page 32). Format: display [parameter # or name] [parameter # or name] Example: d 1 fulllo ad o l displays the values of parameters 1, 16 and 21
extendedhistory	xh	None	Displays the minimum and maximum values of parameters 1 (Vac In), 2 (Vac Out), 7 (Vdc) and 5 (VA Out); the command then clears the minimum and maximum values (see Table 4 on page 32).
format	f	None	Displays an 80-character line containing information on the FERRUPS' status. CheckUPS II and other UPS monitoring software use this data.
help	? or he	None	Shows a list of terminal/computer commands.
history	h	None	Displays the minimum and maximum values of parameter 1 (Vac In); the command then clears the minimum and maximum values.
identify	l	None	Shows Powerware's address and telephone number and the software version.
inverterlog	il	None	Displays the Inverter Log. See "Alarm and Inverter Logs" on page 62.
logs	l	None	Displays both the Alarm and Inverter Logs. See "Alarm and Inverter Logs" on page 62.
off [time]	o [time]	None*	Shuts down the UPS a given number of seconds. The READY indicator flashes until the UPS shuts down, and the UPS beeps five seconds before shutdown. Example: OFF 60 shuts down the UPS in 60 seconds.
off [time] autostart	o [time] a	None*	Shuts down the UPS in a given number of seconds (see above), and restarts the UPS shortly after power returns.
off cancel	o c	None*	Cancels timed shutdown.
parameters	p	Depends on parameter password	Shows a list of system parameters. See "Parameters" on page 32. You can also display a range of parameters by entering the starting and ending parameter number or name after the command. Example: Parameters 1 10 displays parameters 1 through 10.

*If you change parameter 39 to "Yes," this command requires a User password.

Command	Short Form	Password	Function
paramkeywords	pk	Depends on parameter password	Displays all parameters and their keywords (the names you can use with commands). You can also display a range of parameters by entering the numbers or names of the starting and ending parameters.
password	pw	None	Allows you to enter the User Password. Typing password alone clears the current password. Example: password 377 enters the User Password.
program	pr	Depends on parameter password	Lets you set the value of any parameter. You must enter the appropriate password before you reset the value. See the Password command above. Format: PR [parameter # or name] [newvalue] Example: PR 0 815 resets the time (parameter 0) to 8:15 a.m.
remote	rm	None	Configures the RS-232 port so the connected terminal works like a control panel.
shutdown or shutdown autostart	sd sd a	None*	Shuts down the UPS output in 60 seconds (if you enter shutdown alone) or the number of seconds you specify after the command. The READY indicator flashes until the UPS shuts down. If you specify autostart , the UPS restarts shortly after power returns.
shutdown cancel	sd c	None*	Cancels a shutdown started with the shutdown command.
shutup	sh	None	Turns off audible alarm.
status	s	None	Shows date, time, system status, present system mode, active alarms, and the value of various system parameters.
systemmode _	sm	None*	Typing systemmode alone displays which system mode is now active. You can use systemmode with a, o, i, or l to enter one of the modes below.
systemmode auto	sm a	None*	Enters the Auto mode. This is the normal FERRUPS UPS mode. In this mode, the UPS provides conditioned AC power to your equipment; if there is a power outage, the UPS is ready to switch to battery power.
systemmode off	sm f	None*	Enters the Off mode. In this mode, the UPS is not providing power to your equipment, but you can still use the UPS control panel.
systemmode inverter	sm l	None*	Enters the Inverter On mode. In this mode, the UPS is converting DC battery power to AC power for your equipment.
systemmode linecondition	sm l	None*	Enters the Line Condition mode. In this mode, the UPS provides conditioned AC power to your equipment, but it does not switch to battery power if there is a power outage. Instead, the UPS sounds a Low AC Out alarm.

*If you change parameter 39 to "Yes," this command requires a User password.

Command	Short Form	Password	Function
systemtest	stst	None*	Starts a system test of the logic, inverter and battery.
time	t	None	Shows the current UPS time. To set the time, enter [hour]:[minutes] after the command.
unshutup	u	None	Turns audible alarm back on.

*If you change parameter 39 to "Yes," this command requires a User password.

Remote Monitoring

Alarm Signal Contacts: These are relay contacts (rated at 25 Vac/Vdc and 250 mA) that change status on any alarm condition or when the UPS is turned off. Contacts that close on an alarm are available between Pins 23 and 24. Contacts that open on an alarm are available between Pins 24 and 25.

Inverter On Signal Contacts: These are relay contacts (rated at 25 Vac/Vdc and 250 mA) that change status when the inverter turns on. Contacts that close on inverter operation are available between Pins 12 and 13. Contacts that open on inverter operation are available between Pins 11 and 13.



NOTE FE 500 VA–3.1 kVA models with serial numbers 25000 and greater have equivalently rated DC solid state switches.

Remote Shutdown

The FERRUPS UPS can be connected to a remote shutdown switch to shut off output from the UPS to your protected equipment. The shutdown switch must have a set of contacts that can apply the UPS's +12 Vdc on Pin 6 to the UPS's Pin 21. (You can use Pin 18 instead of Pin 6; **do not use Pin 14.**) Use a shielded, single twisted-pair cable to connect the switch to the UPS pins. A connection between Pins 6 and 21 (or 18 and 21) shuts down UPS output power to the protected equipment.

When the UPS Remote Shutdown feature has been activated, the UPS is in the Off mode and the Emergency Power Off alarm sounds. A control panel or a terminal connected to the UPS displays "Emergency PwrOff."

To restart the UPS, break the connection between Pins 6 and 21 (or between Pins 18 and 21) at the UPS's RS-232 port. Then, follow the steps in "Startup" on page 17 for your model. Note that the 12V level on Pin 6 or Pin 18 is only available when the UPS is operating.

You can change the type of signal that the UPS responds to and how quickly it responds. You can also set up the UPS to restart automatically when the shutdown signal stops. See TIP 503 or contact your service representative for more information.



CHAPTER 6

OPTIONS

Powerware offers many options for your FERRUPS UPS. If you would like more information, contact your local Powerware office or distributor.

Bypass Switches

If your UPS does not have a plug, a bypass switch lets you transfer your protected equipment to direct AC input power conveniently when it's time to service the UPS. Contact your local Powerware office or distributor for recommendations and additional information on the different bypass switches.

Control Panel

Control panels and extension cables are available that provide UPS monitoring and operation from a remote location.

Environmental Monitoring

Powerware's EnviroCom™ monitors office and UPS conditions and phones you when there is a problem. EnviroCom II also lets you:

- call the UPS for an update on its status and environment
- control and communicate with the UPS through a modem

Extended Runtimes

If you want extended runtimes, call your local Powerware office or distributor for information on adding additional battery capacity or an optional battery charger.

Warranties

Besides our standard two-year warranty, Powerware offers several warranty enhancement plans to meet your service and maintenance needs. Contact your local Powerware office or distributor for more information.



CHAPTER 7

MAINTENANCE



NOTE Technicians must observe important safety precautions while performing these checks.

The FERRUPS UPS is designed to provide years of trouble-free operation. Its internal control system checks the batteries and inverter periodically to ensure reliable operation. In fact, you'll probably find that your FERRUPS system requires less maintenance than any of your other computer peripherals.

Nevertheless, the FERRUPS UPS and optional external battery cabinets do require some attention to assure continued reliable service. Powerware recommends that you schedule preventive maintenance checks at least every six months. At these checks, the service technician should follow Powerware's recommended maintenance schedule, which includes the following items:

- Check operating environment for clean, cool, dry conditions.
- Inspect and clean the unit.
- View and record the alarm and inverter logs.
- Check the batteries.
- Check the AC and DC meter functions and recalibrate if necessary.
- Perform an outage test.
- Check and record the values of the first 19 parameters while the UPS is online and on battery.

For more information on preventive maintenance checks, contact your service representative.



CHAPTER 8

SPECIFICATIONS

Table 9. FE and QFE 500 VA–3.1 kVA

Model	500 VA/ 350W	700 VA/ 500W	850 VA/ 600W	1.15 kVA/ 800W	1.4 kVA/ 1 kW	1.8 kVA/ 1.25 kW	2.1 kVA/ 1.5 kW	3.1 kVA/ 2.2 kW
AC Input Voltage and Current, Standard Charger								
FE: 120 Vac	4.6A	5.6A	6.6A	8.9A	11A	16A	19A	25A
208 Vac ¹	2.4A	2.8A	3.7A	5.0A	6.0A	9.2A	11A	14A
220 Vac	2.3A	2.7A	2.5A	4.6A	5.8A	7.8A	9.4A	12A
240 Vac ¹	2.1A	2.5A	3.2A	4.2A	5.3A	8.2A	9.2A	12A
QFE: 120 Vac	4.4A	5.8A	7.0A	8.4A	11A	15A	16A	24A
220 Vac	2.6A	3.9A	4.4A	4.9A	5.7A	7.9A	8.2A	13A
230 Vac	2.5A	3.8A	4.2A	4.6A	5.4A	7.5A	7.8A	12A
240 Vac	2.4A	3.5A	4.0A	4.4A	5.2A	7.2A	7.4A	12A
Recommended AC Input Service: 60 Hz with 120 Vac ¹	10A	10A	10A	15A	15A	20A	20A	30A
Output Voltage and Maximum Output Current ²								
FE: 120 Vac	4.1A	5.9A	7.0A	9.3A	12A	15A	17A	26A
208 Vac	2.3A	3.3A	4.0A	5.3A	6.5A	8.4A	9.9A	15A
220 Vac	—	—	—	5.0A	6.1A	8.0A	9.0A	14A
240 Vac	2.1A	2.8A	3.4A	4.7A	5.6A	7.3A	8.6A	13A
QFE: 120 Vac	4.1A	5.7A	7.1A	9.4A	12A	14A	17A	25A
220 Vac	2.2A	3.2A	3.8A	5.0A	6.4A	7.9A	9.3A	14A
230 Vac	2.2A	3.1A	3.6A	4.8A	6.2A	7.6A	8.9A	13A
240 Vac	2.1A	2.9A	3.5A	4.6A	5.9A	7.2A	8.5A	13A
Efficiency on AC Line	85%	86%	85%	88%	88%	90%	90%	91%
On Line BTU/hour:	210	277	361	372	465	474	568	742
kW/hour:	.062	.081	.106	.109	.136	.139	.166	.217
Audible Noise (dB)	41	41	47	49	49	51	51	51

Model	500 VA/ 350W	700 VA/ 500W	850 VA/ 600W	1.15 kVA/ 800W	1.4 kVA/ 1 kW	1.8 kVA/ 1.25 kW	2.1 kVA/ 1.5 kW	3.1 kVA/ 2.2 kW
Runtime (minutes)								
QFE Full Load:	9	14	11	18	14	11	9	14
Half Load:	25	35	28	48	37	30	25	35
FE Full Load:	9	11	9	8	11	11	9	14
Weight :								
Without Battery:								
60 Hz Models:	44 lb	46 lb	51 lb	92 lb	106 lb	120 lb	132 kg	144 lb
50 Hz Models:	22.2 kg	25 kg	27.7 kg	41.7 kg	45.4 kg	58.1 kg	63.5 kg	69 kg
With Battery:								
60 Hz Models:	54 lb	62 lb	67 lb	102 lb	122 lb	176 lb	188 lb	248 lb
50 Hz Models:	28 kg	36.3 kg	39 kg	59.9 kg	69.9 kg	83 kg	89 kg	116.1 kg
Dimensions (H x W x D)	12" x 10" x 21.25" 30.5 x 25.5 x 54.0 cm			15.1" x 15.2" x 20.2" 38.5 x 39.0 x 51.5 cm		21.2" x 15.25" x 22.9" 54.0 x 39.0 x 58.5 cm		

¹Size input protection according to all applicable local or national codes. Fuse and circuit breaker sizes vary. Sizes shown are for the U.S. and Canada.

²At 0.7 leading power factor.

Table 10. FE and QFE 4.3–18 kVA

Model	4.3 kVA/ 3 kW	5.3 kVA/ 3.7 kW	7 kVA/ 5 kW	10 kVA/ 7.5 kW	12.5 kVA/ 10 kW	18 kVA/ 15 kW
AC Input Voltage and Current, Standard Charger						
FE: 120 Vac	32A ¹	38A ¹	51A ¹	—	—	—
208 Vac	18A	22A	30A	45A	58A	86A
220 Vac	17A	21A	27A	41A	53A	81A
240 Vac	16A	19A	26A	39A	50A	76A
QFE: 220 Vac	19A	21A	27A	43A	55A	81A
230 Vac	18A	20A	26A	41A	53A	78A
240 Vac	17A	19A	24A	39A	51A	75A
Recommended Input Service for 60 Hz Models ²	120 = 40A ¹ 208 = 25A 240 = 20A	120 = 50A ¹ 208 = 30A 240 = 25A	120 = 65A ¹ 208 = 40A 240 = 35A	208 = 60A 240 = 50A	208 = 75A 240 = 65A	208 = 115A 240 = 100A

Model	4.3 kVA/ 3 kW	5.3 kVA/ 3.7 kW	7 kVA/ 5 kW	10 kVA/ 7.5 kW	12.5 kVA/ 10 kW	18 kVA/ 15 kW
Output Voltage and Maximum Output Current ³						
FE: 120 Vac	34A	44A	58A	82A	103A	149A
208 Vac	20A	26A	34A	48A	58A	84A
220 Vac	19A	24A	31A	46A	55A	82A
240 Vac	17A	22A	29A	41A	51A	73A
QFE: 220 Vac	19A	23A	31A	45A	56A	84A
230 Vac	18A	22A	30A	43A	52A	76A
240 Vac	17A	21A	28A	41A	51A	73A
Efficiency On AC Line	90%	90%	90%	90%	91%	92%
On Line BTU/hour:	1138	1403	1896	2844	3375	4452
kW/hour:	.333	.411	.556	.833	.989	1.3
Audible Noise (dB)	50	51	54	55	56	57
Runtime (minutes)						
Full Load:	8	20	12	11	18	10
Half Load:	20	50	33	26	48	26
Weight :						
Without Battery:						
60 Hz Models:	243 lb	268 lb	362 lb	442 lb	505 lb	625 lb
50 Hz Models:	115.7 kg	131.1 kg	176.5 kg	217.7 kg	251.3 kg	312.1 kg
With Battery:						
60 Hz Models:	348 lb	484 lb	578 lb	—	—	—
50 Hz Models:	163.3 kg	229.1 kg	274.4 kg	—	—	—
N Cabinet with Standard Batteries	—	—	—	395 lb (179.2 kg)	535 lb (242.7 kg)	675 lb (306.2 kg)
Dimensions (H x W x D) ⁵	29.5" x 15.5" x 25" 75.0 x 39.5 x 63.5 cm			36.5" x 19" x 32" 93.0 x 48.5 x 81.5 cm		

¹FE 4.3 kVA, 5.3 kVA, and 7 kVA models have optional 120 Vac input voltage.

²Size input protection according to all applicable local or national codes. Fuse and circuit breaker sizes vary. Sizes shown are for the U.S. and Canada.

³At 0.7 to 0.83 leading power factor.

⁴FE and QFE 10 kVA, 12.5 kVA, and 18 kVA models do not have internal batteries. Batteries are in a separate battery cabinet or rack.

⁵If your model has an internal bypass switch, add 8" (20.0 cm) to the depth.

Table 11. Electrical Input and Output

Nominal Frequency	Online: 60 Hz (FE) or 50 Hz (QFE) with nominal power line grid stability of ± 0.005 Hz. On inverter: 60 Hz (FE) or 50 Hz (QFE) ± 0.03 Hz. Output frequency tracks input line frequency up to limit, which is adjustable from ± 0.01 Hz to ± 3.00 Hz. Inverter turns on if line frequency exceeds the selected limit.
Regulation	$\pm 3\%$ load regulation (under any line, load, or battery condition to within -8.3% and $+5\%$ of nominal)
Voltage Waveform	Sine wave; $<5\%$ THD at rated linear loads, computer-grade power
Overload Capability	On line (nominal Vac in): 150% surge and 125% for 10 minutes. On inverter (nominal Vdc in): 150% surge and 110% for 10 minutes. Overload operation is not thermally limited. The FERRUPS UPS microprocessor continuously monitors output VA and sounds an alarm before loss of output voltage regulation occurs.
DC Input Protection	DC fuse and battery charger fuse
Output Protection	Output Protection: The ferroresonant transformer inherently limits current and provides overload protection. The FERRUPS UPS has high AC and low AC output voltage alarms, as well as an overload alarm. If the AC output voltage falls below the low AC output voltage alarm setpoint, the UPS sounds an alarm after five seconds. If the AC output voltage falls below the low AC output shutdown setpoint, the UPS sounds an alarm and shuts down. Some models have output receptacles protected by fuses or circuit breakers.
Lightning and Surge Protection	The FERRUPS UPS provides 2000-to-1 spike attenuation. Tested using lightning standard per ANSI/IEEE C62.41 Category A (6000V spike and 200A) and Category B (6000V spike and 3000A) test, and ANSI/IEEE C62.45 test procedures.
Isolation, Including Output Neutral to Ground Bonding	The FERRUPS UPS provides a true separately derived power source, as defined by National Electrical Code Article 250-5d, with output neutral bonded to ground. There is no direct connection between input and output, and less than 2 pF of effective input to output capacitance.

Table 12. Environmental and Safety

Operating Temperature	0°C to 40°C (32°F to 104°F)
Storage Temperature	UPS with batteries: -20° to +40°C (-4° to 104°F) UPS without batteries: -20° to +60°C (-4° to 140°F)
Relative Humidity	0–95% noncondensing
Operating Altitude	Up to 3,050 meters above sea level (10,000 ft) The maximum operating ambient temperature decreases 1°C per 300m above 1525m (2°F per 1000 ft above 5000 ft)
Ventilation	The air around the UPS must be clean and free of dust, corrosive chemicals, and other contaminants. The FERRUPS UPS uses internal fans to circulate the air for cooling. The air must be free to circulate around the UPS and battery cabinet(s). Do not operate the UPS in a sealed room or container.
Noise Rejection	Common Mode: Greater than 120 dB with output neutral bonded to ground Transverse (Normal) Mode: Greater than 60 dB

Table 13. Battery

Voltage	500–850 VA models: Nominal battery voltage is 24 Vdc for 60 Hz, 12 Vdc for 50 Hz. Standard battery charger output is rated at 2A. 1.15–1.4 kVA models: Nominal battery voltage is 48 Vdc for 60 Hz, 12 Vdc for 50 Hz. Standard battery charger output is rated at 2A. 1.8–3.1 kVA models: Nominal battery voltage is 48 Vdc. Standard battery charger output is rated at 4A. 4.3–7 kVA models: Nominal battery voltage is 48 Vdc. Standard battery charger output is rated at 5A. 10–18 kVA models: Nominal battery voltage is 120 Vdc. Standard battery charger output is rated at 5A.
Type	Standard batteries are sealed, gas recombinant, lead-acid type, especially designed for UPS use.

NOTE Optional battery chargers at higher current ratings are available. Call your local Powerware office or distributor for more information.



CHAPTER 9

TROUBLESHOOTING

When your FERRUPS UPS detects an alarm condition, the UPS displays the alarm with the following indications:

- the ALARM indicator on the front panel (and the control panel if you have one) illuminates
- sounds an audible alarm
- displays an alarm message on the control panel (if you have one).



NOTE If the control panel does not display the message, press [CLEAR] until you reach the scrolling display.

Alarms

When an alarm occurs, follow these steps:

1. Find out which alarm condition the UPS is detecting.
 - If you have a control panel, you can read the alarm on the display.
 - If you do not have a control panel, listen to the alarm code; the UPS sounds the Morse Code for the alarm letter.
2. Find the alarm in Table 14 and follow the instructions to resolve the problem.
3. To silence the alarm:
 - FE/QFE 500 VA–3.1 kVA models:** Turn the Alarm Silence Switch on the UPS rear panel to the OFF position.
 - FE/QFE 4.3–18 kVA models:** Press [CTRL]-[5] [ENTER] [ENTER] on the control panel.
4. After the alarm condition is cleared, turn the alarm beep back on (using either the switch or the control panel).



NOTE If you do not turn the alarm beep back on, the UPS is not able to sound an alarm code the next time there is an alarm.

Table 14. Alarms

Letter	Audio Code	Alarm Message	What It Means	What To Do
A	• –	Low Battery	The UPS has shut down after running on battery and discharging the batteries.	Wait for AC input power to be restored. When AC input power returns, turn on the UPS. The CHARGING indicator illuminates as the UPS begins recharging batteries.
B	– • • •	Near Low Battery	The battery voltage has reached the Near Low Battery setpoint.	The alarm should clear itself when the battery charger has charged the batteries enough.
C	– • – •	High Battery	The battery voltage is too high because of a problem with the charging circuit or parameter settings.	Contact your service representative.
D	– • •	Low Runtime	The UPS is running on battery power, and the battery runtime remaining is low.	Shut down your equipment and turn off the UPS to conserve battery power. When AC input power returns, turn the UPS on again.
E	•	Low AC Output	The output voltage is below a preprogrammed setpoint.	The UPS shuts down. Shut down your equipment or bypass the UPS, and turn the UPS switch off. Contact your service representative.
F	• • – •	High AC Output	The output voltage is higher than the alarm setting.	Contact your service representative.
G	– – •	Output Overload	Power requirements exceed UPS capacity (check the UPS VA rating) or the load is defective.	Turn off and unplug the UPS. Remove some of the equipment from the UPS. Restart the UPS. If the overload condition persists (125% for 10 minutes), the UPS automatically shuts down.
H	• • • •	Hi Ambient Temp	The temperature inside the UPS is too high. If the temperature reaches a preset point, the UPS shuts down.	If the UPS has shut down, contact your service representative. If not, shut down the protected equipment and the UPS, correct the cause of the high temperature if possible, and turn the UPS on again. If the problem persists, contact your service representative.
I	• •	Hi Heatsink Temp	The inverter temperature is too high. If the temperature reaches a preset point, the UPS shuts down.	If the UPS has shut down, contact your service representative. If not, shut down your equipment or bypass the UPS; turn the UPS off. Contact your service representative.

Letter	Audio Code	Alarm Message	What It Means	What To Do
J	• ---	User Test Alarm	The user is testing the alarm feature.	To start the user test alarm from the control panel, press [CTRL]-[8] [ENTER] [ENTER]. Repeat the procedure to turn the alarm off.
K	-- •-	Hi Transfmr Temp	The transformer temperature is too high. If the temperature reaches a preset point, the UPS shuts down.	The UPS may have shut down; if so, contact your service representative. If the UPS has not shut down, shut down your equipment or bypass the UPS; then, turn the UPS off and contact your service representative.
L	• - • •	Check Charger	The UPS has detected a charger problem.	Contact your service representative.
M	--	Check Battery	The batteries have failed the automatic system test.	Contact your service representative.
N	- •	Check Inverter	The inverter has failed the automatic system test.	Contact your service representative.
O	----	Memory Check	Possible microprocessor problem.	Shut down your equipment or bypass the UPS; turn off the UPS. Contact your service representative.
P	• - - •	Emergency PwrOff	The Remote Shutdown feature has been activated at the RS-232 port (see "Remote Shutdown" on page 47.)	To restart the UPS, disconnect the signal to Pin 21 on the RS-232 port. If you have a control panel, put the UPS in Auto mode. If not, turn the On/Off switch off and then on again.
Q	-- • -	Hi PFM Res Temp	The Power Factor Module's temperature is too high. If the temperature reaches a preset point, the UPS shuts down.	If the UPS has shut down, contact your service representative. If not, shut down your equipment or bypass the UPS; then, turn the UPS off and contact your service representative.
R	• - •	Probe Missing	A temperature probe is missing or damaged.	The UPS may shut down. Contact your service representative.
S	• • •	High AC Input	The input voltage is higher than the alarm setting.	Contact your service representative.

Letter	Audio Code	Alarm Message	What It Means	What To Do
T	–	Call Service	The UPS has detected a problem that requires service.	The UPS shuts down. Contact your service representative.
W	• – –	Fan Alarm	The fan has stopped.	The UPS may have shut down; if so, contact your service representative. If the UPS has not shut down, shut down your equipment or bypass the UPS; then, turn the UPS off and contact your service representative.

Alarm and Inverter Logs

Your FERRUPS UPS makes an entry in its logs every time it sounds an alarm or switches to inverter (battery power). This information can be helpful in diagnosing problems.

You can view the Alarm and Inverter Logs from either the UPS control panel or a terminal or computer that you have connected to the RS-232 port (see “Connecting a Terminal or Computer to the RS-232 Port” on page 41).

Reading the Alarm Log from a Control Panel

The Alarm Log is parameter 25. To display the Alarm Log from a control panel, follow these steps:

Press this key:	Display shows:
[DISPLAY]	Display:
[2][5]	Display: 25
[ENTER]	25 Alarm Log

The display scrolls through the 20 most recent entries in the Alarm Log. If you have not had 20 alarm conditions, the display scrolls through the entries FERRUPS has recorded. You can use the number keys as you view this scrolling display:

Use this key:	To do this:
[0]	Pause the scrolling and start it again.
[1] through [9]	Go to the next log entry.

Each log entry consists of four pieces of information: the alarm code, the date (month/day) of the alarm, the time (in 24-hour time) and the duration (in hours and minutes).

For instance, one entry might look like this:

B 0205 1017 0005

In this example, “B” means the alarm was “Near Low Battery” (see “Alarms” on page 59); if alarm B was active, there would be an asterisk (*) after “B.” “0205” means the alarm occurred on February 5 (2/5). “1017” means the alarm occurred at 10:17 a.m. “0005” means the alarm condition lasted for 0 hours and 5 minutes.

Reading the Inverter Log from a Control Panel

The Inverter Log is parameter 24. To display the Inverter Log, follow these steps:

Press this key:	Display shows:
[DISPLAY]	Display:
[2][4]	Display: 24
[ENTER]	24 Inverter Log

The display scrolls through the 20 most recent entries in the Inverter Log. If the inverter has not run 20 times, the display scrolls through the entries the UPS has recorded. You can use the number keys as you view this scrolling display:

Use this key:	To do this:
[0]	Pause the scrolling and start it again.
[1] through [9]	Go to the next log entry.

Each entry includes four pieces of information: the inverter code, the date (month/day) of the inverter run, the time (in 24-hour time) and the duration (in hours and minutes). For instance, one entry might look like this:

L 0205 0951 0015

In this example, “L” means the the UPS went to inverter because it lost AC input power; if the inverter was still running, there would be an asterisk (*) after the “L.” “0205” means the inverter ran on February 5 (2/5). “0951” means the inverter ran at 9:51 a.m. “0015” means the inverter ran for 0 hours and 15 minutes.

Table 15. Inverter Codes

Inverter Code	Meaning	Explanation
T	System Test	UPS went to inverter to test the batteries.
B	Brownout	AC input voltage was too low.
L	Line Loss	AC input power was lost.
M	Manual	The inverter was started manually.
F	Frequency	Input frequency was too high or too low.
R	Reset	A system reset was performed.

Reading the Alarm Log from a Terminal or Computer

To display the Alarm Log on a terminal or computer, you can use the `alarmlog` or `logs` command (see “Entering Commands from a Terminal or Computer” page 44). These commands display up to 20 log entries in a table. For example, the log might look like this table:

Active	EventDate	EventTime	Duration	Code/Event
No	08/25/1993	11:25:32	00:00:45	J-User Test Alarm
No	08/24/1993	12:13:18	00:01:08	A-Low Battery
No	08/24/1993	12:05:07	00:08:11	B-Near Low Battery

The table shows whether the alarm is active now (Active), the date and time of each alarm, how long it lasted (Duration), and what caused the alarm (Code/Event).

You can also display parameter 25 to view the Alarm Log; this display is the same as the control panel display.

Reading the Inverter Log from a Terminal or Computer

To display the Inverter Log on a terminal or computer, you can use the `inverterlog` or `logs` command (see “Entering Commands from a Terminal or Computer” page 44). These commands display up to 20 log entries in a table. For example, the log might look like this:

Active	EventDate	EventTime	Duration	Code/Event
No	08/25/1993	11:25:32	00:00:45	M-Manual turnon
No	08/24/1993	12:13:18	00:01:08	L-Line fault

The table shows whether the UPS is running on inverter (battery power) now (Active), the date and time that the UPS ran on battery power, the length of time the UPS ran on battery power (Duration), and the reason (Code/Event).

You can also display parameter 24 to view the Inverter Log; this display is the same as the control panel display.

Alarm Code Summary

A	•–	Low Battery	L	•–••	Check Charger
B	–•••	Near Low Battery	M	––	Check Battery
C	–•–•	High Battery	N	–•	Check Inverter
D	–••	Low Runtime	O	–––	Memory Check
E	•	Low AC Output	P	•––•	Emergency PwrOff
F	••–•	High AC Output	Q	––•–	Hi PFM Res Temp
G	––•	Output Overload	R	•–•	Probe Missing
H	••••	Hi Ambient Temp	S	•••	High AC Input
I	••	Hi Heatsink Temp	T	–	Call Service
J	•–––	User Test Alarm	W	•––	Fan Alarm
K	–•–	Hi Transfmr Temp			

Figure 12. Alarm Code Summary

Service and Support

If you have any questions or problems with the UPS, call your **Local Distributor** or the **Help Desk** at one of the following telephone numbers and ask for a UPS technical representative.

In the United States: **1-800-356-5737** or **1-608-565-2100**

Europe, Middle East, Africa: **+44-17 53 608 700**

Asia: **+852-2830-3030**

Australia: **+61-3-9706-5022**

Please have the following information ready when you call the Help Desk:

- Model number
- Serial number
- Version number (if available)
- Date of failure or problem
- Symptoms of failure or problem
- Customer return address and contact information

If repair is required, you will be given a Returned Material Authorization (RMA) Number. This number must appear on the outside of the package and on the Bill Of Lading (if applicable). Use the original packaging or request packaging from the Help Desk or distributor. Units damaged in shipment as a result of improper packaging are not covered under warranty. A replacement or repair unit will be shipped, freight prepaid for all warranted units.



NOTE For critical applications, immediate replacement may be available. Call the **Help Desk** for the dealer or distributor nearest you.

Free Manuals Download Website

<http://myh66.com>

<http://usermanuals.us>

<http://www.somanuals.com>

<http://www.4manuals.cc>

<http://www.manual-lib.com>

<http://www.404manual.com>

<http://www.luxmanual.com>

<http://aubethermostatmanual.com>

Golf course search by state

<http://golfingnear.com>

Email search by domain

<http://emailbydomain.com>

Auto manuals search

<http://auto.somanuals.com>

TV manuals search

<http://tv.somanuals.com>