

# OWNER'S MANUAL



## AMPLIFIER MODELS

*DCX 300.4*

*DCX 600.4*

*DCX 800.5*

*DCX 1000.4*

## TABLE OF CONTENTS

---

Congratulations	2
Service	2
Caution	2
Features	3
Specifications	3
Fuse Requirements	4
Amplifier Status LEDs	5
QBASS/QBASS PLUS Specifications	6
Tools/Parts for Installation	6
Wiring	7
Ground Wiring	9
Charging System	9
Current Draw	10
Power Wire Size	11
Power Lock Connectors	11
Amplifier Bridging	11
Mixed Mono Output	12
DCX 300.4 Front Plate Diagram	13
DCX 300.4 End Plate Diagram	14
DCX 600.4 and DCX 1000.4 Front Plate Diagram	15
DCX 800.5 Front Plate Diagram	17
DCX 600.4, DCX 800.5, DCX 1000.4 End Plate Diagram	19
Inputs	19
DCX 300.4, 600.4, 1000.4 Block Diagram	20
DCX 800.5 Block Diagram	21
Advanced Instrumentation Input	22
QBASS	22
QBASS PLUS	23
TC-X Crossover	23
Crossover Detent Chart	25
Input Combine	26
Adjusting Input Gain	26
High Mass Internal Heatsink	26
Forced Air Thermal Management	26
AP-IV Protection Circuit	27
Troubleshooting	28

## **CONGRATULATIONS**

---

Thank you for choosing *PrecisionPower™* audio equipment. Designed and engineered in the USA, this product combines innovative technology with the finest materials to consistently deliver *Absolutely State of the Art™* performance, sound quality, reliability, and value. This *PrecisionPower™* product reflects our commitment to offer you unparalleled performance and quality for years of dependable service and listening enjoyment.

## **SERVICE**

---

Do not attempt to service *PrecisionPower™* products yourself. Performing maintenance on your audio equipment will void the warranty. Many parts of the *PrecisionPower™* product are custom built to our specifications. **Our factory parts are not made available to anyone else nor are they for sale.** Our goal is to make sure that your *PrecisionPower™* product will always sound as good as the day it was purchased. Contact your *Authorized PrecisionPower™ Dealer* about obtaining any warranty service through *PrecisionPower™*. (See the Warranty on the outside of the back cover).

## **CAUTION**

---

Extended use of a high powered audio system may result in hearing loss or damage. While *PrecisionPower™* systems are capable of "Concert Level" volumes with incredible accuracy, they are also designed for you to enjoy at more reasonable levels all of the sonic subtleties created by musicians. Please observe all local sound ordinances.

## FEATURES

---

Advanced Instrumentation Input Stage  
**TC-X Crossover** 12dB/Octave; HP/LP/FULL; 30-4kHz Crossover  
Adaptive PWM Power Supply (**DCX 300.4, DCX 600.4, DCX 800.5**)  
**AP-IV** Protection Circuitry  
Fully Regulated PWM Power Supply (**DCX 1000.4**)  
Fully Complementary Darlington Output Stage  
Forced Air Thermal Management (**DCX 1000.4**)  
**QBASS™** Bass Boost (**DCX 300.4**)  
**QBASS Plus™** Bass Boost (**DCX 600.4, DCX 800.5, DCX 1000.4**)  
High Voltage Input Capability with -12dB Attention Switch  
Gold Plated RCA Input and Output Connectors  
**PowerLock™** Speaker and Power Wire Connectors  
Mixed Mono/Stereo Operation  
2 Yr Warranty if installed by an Authorized *PrecisionPower* Dealer

## SPECIFICATIONS

---

### Power Ratings

<u>MODEL</u>	<u>4ohm STEREO</u>	<u>2ohm STEREO</u>	<u>4ohm MONO</u>
<b>DCX 300.4</b>	4 X 50	4 X 75	2 X 150
<b>DCX 600.4</b>	4 X 75	4 X 150	2 X 300
<b>DCX 1000.4</b>	4 X 125	4 X 250	2 X 500
<b>DCX 800.5</b>	4 X 50	4 X 100	2 X 200
	<u>4ohm MONO</u>	<u>2ohm MONO</u>	
5/Ch.	1 X 200	1 X 400	

**All power ratings given above are tested at 12.5V; 4 ohms; 20Hz - 20kHz.**

### General Specifications

Frequency Response	20Hz - 20kHz
Power Bandwidth	10Hz - 50 kHz
Total Harmonic Distortion	>0.02%
S/N Ratio	<110dB
Input Topology	Instrumentation
Input Sensitivity	150mV - 12 Volts RMS (with -12dB pad)
Input Impedance	40 kOhms
Load Impedance (stereo)	2 - 8 Ohms
Load Impedance (bridged)	4 - 8 Ohms
Supply Voltage	11 - 16 Volts
Damping Factor	>500
Slew Rate	>20V/μs

**QBASS™**  
**QBASS PLUS™**

Crossovers  
Crossover Frequency  
Idle Current:

Up to +18dB @ 40Hz  
Up to +18dB Boost  
@30, 36, 44, or 60Hz  
12dB/Octave  
30-4kHz  
**DCX 300.4** 2 Amps  
**DCX 600.4** 2.5 Amps  
**DCX 1000.4** 3 Amps  
**DCX 800.5** 2.5 Amps

**Dimensions**

	Length	Width	Height
<b>DCX 300.4</b>	21-1/2"	10-1/2"	2-3/4"
<b>DCX 600.4</b>	24-3/4"	10-1/2"	2-3/4"
<b>DCX 1000.4</b>	29-3/8"	10-1/2"	2-3/4"
<b>DCX 800.5</b>	28-1/8"	10-1/2"	2-3/4"

**FUSE REQUIREMENTS**

---

You will need to install an in-line fuse or circuit breaker in the power wire within 18" of the battery. This fuse or circuit breaker is to protect your vehicle from fire in case the power wire shorts to the vehicle body. If you are only using one amplifier, use the fuse rating indicated in this chart. If you are using more than one amplifier, add up the fuse ratings for all the amplifiers. This sum is the rating for your fuse or circuit breaker. You may also want to add a power distribution block near your amplifiers to distribute large gauge power cable to multiple amplifiers.

Amp	Fuse
DCX 300.4	50A
DCX 600.4	70A
DCX 1000.4	100A
DCX 800.5	100A

## AMPLIFIER STATUS LEDS

---

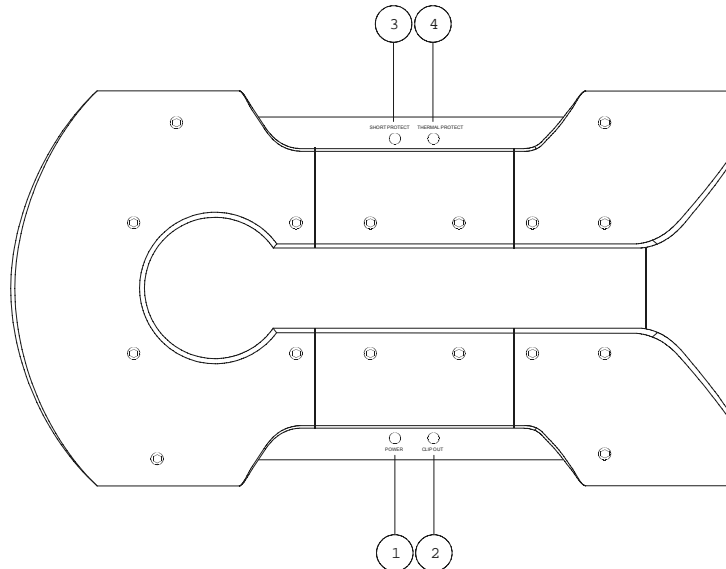

The LEDs provide the following indications:

- 1. Power** - This LED illuminates RED when the amplifier power is turned on with the remote input (output muted). After a short time delay this LED will turn GREEN (amplifier ready).
- 2. Clip Output** - This LED illuminates RED on the peaks of the output signal when the peaks are too high. This clipping causes audible distortion in the speakers.
- 3. Short** - This LED illuminates RED on a short condition. The amplifier will turn off and try to turn back on.
- 4. Thermal** - This LED illuminates RED on a thermal condition. The amplifier will turn off and turn back on in a minute or so.

**Note:** Read the **AP-IV Protection Circuit** section for additional information regarding **Short and Thermal** protection.

## **QBASS/QBASS PLUS SPECIFICATIONS**

---

### **QBASS™ (DCX 300.4)**

Up to 18dB of boost centered at 40Hz, with a Q-factor of 2.

### **QBASS PLUS™ (DCX 600.4, 1000.4, 800.5)**

Up to 18dB of boost with selectable center frequency at 30Hz, 36Hz, 44Hz or 60Hz, with a Q-factor of 2.

### Optional **QBASS REMOTE™ (DCX 600.4, 1000.4, 800.5)**

This boost control can be mounted in the dash and will supersede the boost control on the amplifier endplate.



## **TOOLS/PARTS FOR INSTALLATION**

---

**NOTE: TOOLS ARE NOT SUPPLIED.**

Small flat blade screwdriver  
Phillips screwdriver (#2 or medium sized)  
Wire cutters  
Wire strippers  
4 - #6 round head screws, and 1 - #8 sheet metal screw. (or nut, bolt, flat washer, star washer) (see details)  
2 - Ring connectors (large enough to accommodate your method of grounding)  
In-line fuse or circuit breaker  
Power and ground wire  
Speaker wire - 12-16 gauge  
Grommets (sized to work with the power wire you plan to use in your installation)  
Tube of silicone sealant

## WIRING

Before beginning, disconnect the negative (-) terminal of the battery prior to connecting the amplifier to the positive (+) 12V terminal to prevent a short to ground and potential damage to wiring and equipment. Some vehicle radios have an anti-theft feature where when the radio is removed from 12V the radio will no longer function and must be code reset.

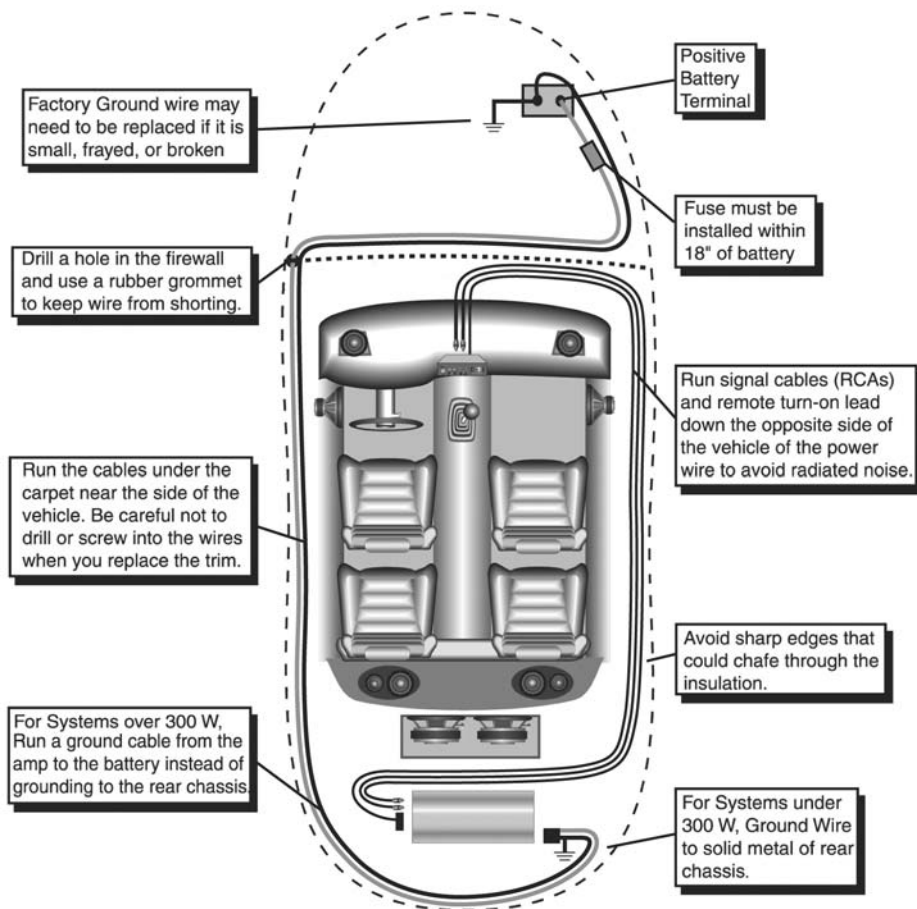

**Note:** The cables running from the battery to the rear of the car should be installed on the side of the car opposite to the antenna.

When using 16 gauge wire or larger, run the speaker wires from the amplifier location through the vehicle to the speakers. Observe the



same precautions for routing these wires that you followed for running the power and remote turn on wires. Cut off excess and, using wire strippers, strip 1/4-inch of insulation. Locate the speaker/remote turn-on **PowerLock™** connector. Loosen the outer screws on the underside of the connector. Insert the speaker leads into the end. Check to be sure you've maintained proper polarity before securing each wire, and plug the **PowerLock™** into the amplifier.

**Note:** The power connector is inserted into the amplifier with the wire clamping screws in the up position as shown below.

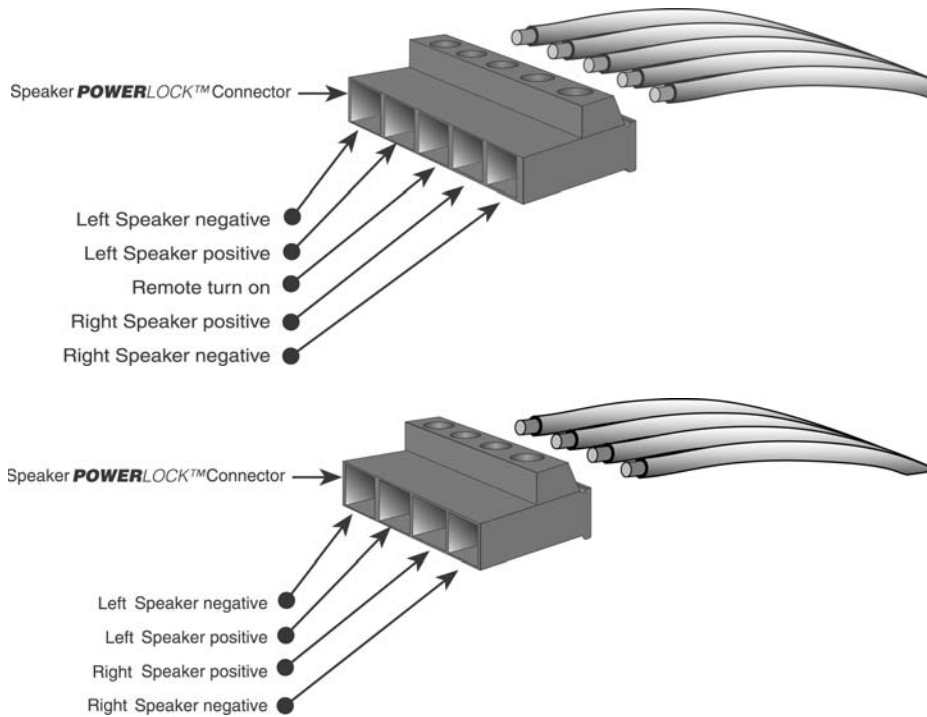

For the rear channels, locate the four terminal speaker **PowerLock™** connector. (For **DCX 800.5**, the 5<sup>th</sup> channel also uses a four terminal **PowerLock™** connector.) On 4 and 5 channel **DCX** amplifiers, all speaker **PowerLock™** plug into the amplifier with the screws facing up. Loosen the screws on the top of the blocks and insert the stripped ends of the speaker wires into the end. Double check polarity, secure each wire by tightening the screws, and plug the **PowerLock™** connector into the amplifier with the screws on top.

## **GROUND WIRING**

---

Locate an area near the amplifier(s) that is metal and clean an area about the size of a quarter down to bare metal. Inspect the area around and underneath to be sure you will not drill into wires, brake or fuel lines, etc. Drill a pilot hole in the middle of this area. Terminate the ground wire with a ring connector and attach it to the bare metal using a #8 sheet metal screw and washer or preferable, a bolt, nut and a star washer. (not supplied). We suggest crimping and soldering this connection. After the connection is complete, coat the area



(on both sides) with silicone or some similar material to prevent rust from developing on the bare metal. If your grand total current draw is over 80 amps (*or total power is over 500 watts*). Keep the ground and power wires as close together as possible, and use the same gauge wire for both. This will ensure that you have a good ground path, and may eliminate such potential problems as engine noise and overheated amplifiers.

## **CHARGING SYSTEM**

---

If your total current draw is over 100 amps (*or total output power is over 600 watts*), you are probably exceeding the capability of your charging system. Dimming lights and fluctuating voltage are solid indicators that you need to upgrade your alternator, battery, or both. You should also check the condition and current capacity of the stock battery negative cable and connections, and replace or upgrade as necessary. Keep in mind that your amplifiers simply convert electrical energy to acoustical energy, and any electrical deficiency will compromise the performance of your sound system. For more information about charging system upgrades, see you local authorized *PrecisionPower™* Dealer or call *PrecisionPower™* Technical Support at **1-800-62POWER x2033**.

## CURRENT DRAW

---

The following is a basic formula to be used as a guide to determine current draw. Your new **DCX** amplifier is more efficient than most other amplifiers. This formula is to be used as a guideline. Using wire of a larger gauge can only improve the current transfer of your system. Do **NOT** use smaller wire gauge.

$$\text{Total RMS output} \times 1.5 = \text{Total Input Wattage}$$

$$\frac{\text{Total Input Wattage}}{\text{Supply Voltage}} = \text{Current Draw (in Amps)}$$

**Example:** A **DCX** amplifier has two channels at 250 watts per channel RMS rating into 4 ohms (250X2 = 500 watts).

You would use the formula in the following way:

$$500 \text{ W} \times 1.5 = 750 \text{ watts}$$

$$\frac{750\text{W}}{12\text{V}} = 62.5 \text{ Amps total current draw}$$

If the same amplifier is driven into a 2 ohm stereo or 4 ohm mono load, double its 4 ohm RMS rating. All **DCX** amplifiers will effectively double their power at this load.

$$500\text{W} \times 1.5 \times 2 = 1500 \text{ watts}$$

$$\frac{1500\text{W}}{12\text{V}} = 125 \text{ Amps total current draw}$$

If you are using more than one amplifier, add up the total current draw for all of them and choose the appropriate gauge based on the grand total.

## **POWER WIRE SIZE**

A minimum of 8 gauge or a maximum of 4 gauge wire is recommended dependent on the application.

The ground wire must be the same gauge as the power wire.

## **POWER LOCK CONNECTORS**

Once you have run both the power and ground wires, then connect the cables to the amplifier. Cut off excess wire, and using wire strippers, strip the ends of the power and ground cables approximately 1/4 inch. Locate the *PowerLock™* power and ground connector (supplied). With a small flat blade screwdriver, loosen the screws before attempting to insert the cable wires. Insert the wires into the appropriate hole, and tighten the screws. Once the wires are secure, the *PowerLock™* may be plugged into the amplifier. The Power/Ground *PowerLock™* will accommodate 6 gauge wire for the **DCX 300.2** and **DCX 600.4**, and 4 gauge wire for the **DCX 800.5** and **DCX 1000.4**.

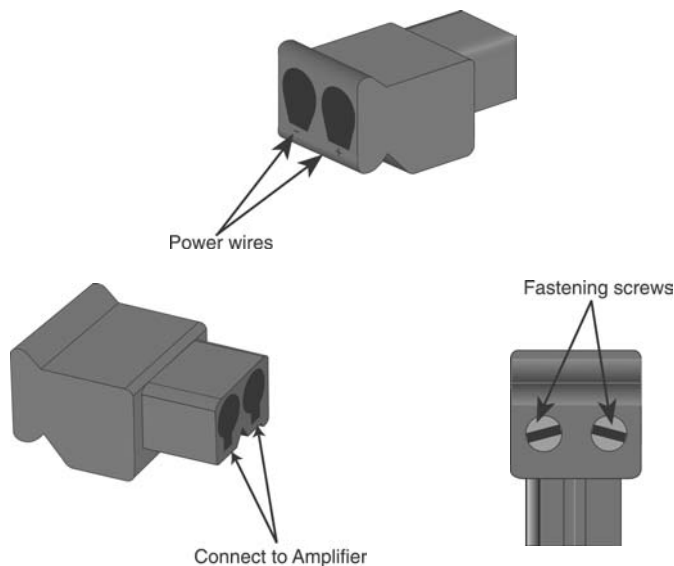

## **AMPLIFIER BRIDGING**

Pairs of channels in **DCX** multi-channel amplifiers are capable of being bridged into a 4 ohm mono output without switches or bridging

modules. This feature permits the creation of a mono channel for a suitable subwoofer or center channel. Deriving the mono channel is accomplished by using the Left Channel Positive wire (**L+**) as the positive speaker wire and the Right Channel Negative wire (**R-**) as the negative speaker wire.

**Note:** It is important that a minimum 4 ohm impedance is observed. If the impedance drops below 4 ohms while the amplifier is wired in the bridged configuration, the amplifier's protection circuitry may engage.

**Note:** This does not apply to the DCX 800.5 sub channel, which can drive a 2 ohm load safely.

#### **MIXED MONO OUTPUT**

---

The ability to run stereo speakers while simultaneously running a mono output from the same amplifier is accomplished by running the stereo speakers normally and tapping into the appropriate wires for the "mixed mono" channel (left channel positive for the positive speaker wire and right channel negative for the negative speaker wire). Speaker impedance should be no lower than 2 ohms on the stereo channels and 4 ohms on the mono channel.

**Note:** Passive crossovers must be used for "mixed mono" operation. Choose a low pass crossover around 100Hz for your subwoofer, then choose a high pass crossover for your stereo channels. The high pass crossover must be at the same or slightly higher frequency than the low pass crossover to maintain the correct impedance. See your *PrecisionPower* dealer or call **1-800-62POWER** for more information about passive crossovers.

## DCX 300.4 FRONT PLATE DIAGRAM

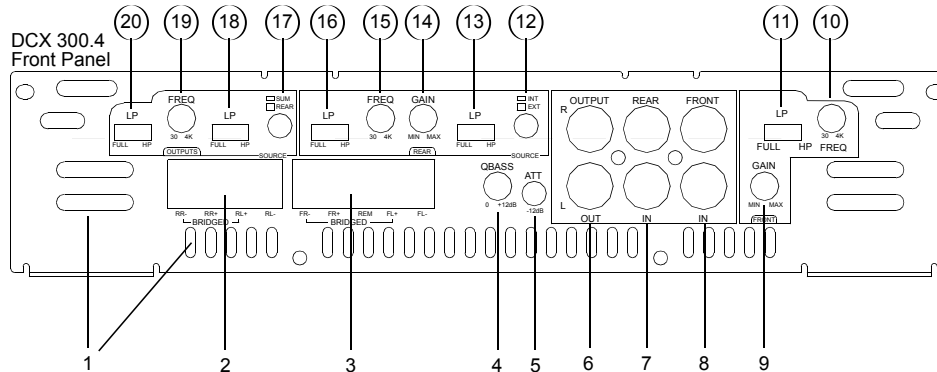

- 1. Cooling Plenums:** Maintain a minimum 2" clearance around cooling plenums for proper amplifier cooling.
- 2. Rear Speaker Connector:** Plug in the *PowerLock™* connector here.
- 3. Front Speaker/Remote Connector:** Plug in the *PowerLock™* connector here.
- 4. QBASS™ Level Control:** Controls bass boost, centered at 40Hz with up to 18dB of boost.
- 5. -12dB Attenuation Switch:** Push this switch 'IN' for high voltage input (4V-12V) capability. This button must be pushed 'IN' for use with speaker level input on common ground head-units or for high voltage line drivers.
- 6. RCA Output:** RCA outputs provide HP/LP/FULL 30-4kHz signal to another amplifier.
- 7. Rear Inputs:** Plug in the rear RCA leads from your source here.
- 8. Front Inputs:** Plug in the front RCA leads from your source here.
- 9. Front Gain:** Use this control to match the output level of the source unit to the front channel of the amplifier.
- 10. Front Freq. Control:** Move this detented control in a clockwise direction to adjust the front crossover frequency from 30Hz to 4 kHz. (see Crossover Frequency chart in this manual).
- 11. Front HP/LP/FULL Switch:** Select the desired crossover setting. HP/LP/FULL for the speaker output signal of the front channel.
- 12. Rear Input INT/EXT Switch:** Select the INT position if you want

to use the internal signal path from the front crossover for the rear input, or the EXT position to use the external rear RCA input.

**13. Source HP/LP/FULL Switch:** Select the desired setting. HP/LP/FULL for the internal signal from the front channel to the rear channel when not using an external rear RCA input.

**14. Rear Gain:** Use this control to match the output level of the head unit to the rear channel of the amplifier.

**15. Rear Freq. Control:** Move this detented control in a clockwise rotation to adjust the rear crossover frequency from 30Hz to 4kHz. (See the Crossover Frequency chart in this manual).

**16. Rear HP/LP/FULL Switch:** Select the desired crossover setting, HP/LP/FULL for the speaker output signal of the rear channel.

**17. Source Sum/Rear Switch:** Select the SUM position if you want to use the RCA output signal summed from the front and rear audio channels, or the REAR position to select the input off of the rear channel only for bandpass capability.

**18. Source HP/LP/FULL Switch:** Select the desired crossover setting. HP/LP/FULL for the output signal of the rear channel when not using the SUM source input.

**19. Output Freq. Control:** Use this control to adjust the rear high pass crossover frequency from 30Hz to 4kHz. (See the Crossover Frequency chart in this manual).

**20. Output HP/LP/FULL Switch:** Select the desired crossover setting. HP/LP/FULL for the signal of the output RCA.

#### **DCX 300.4 END PLATE DIAGRAM**

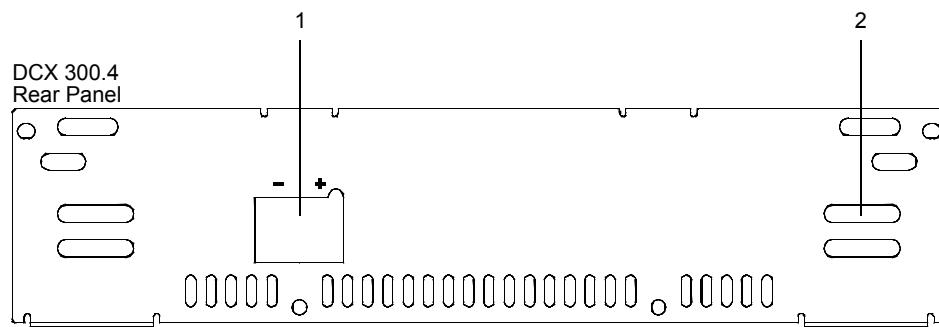

**1. Power/Ground PowerLock™:** After you have securely connected your power and ground wires, plug in the Power/Ground PowerLock™ connector here.

**2. Cooling Plenums:** Maintain a minimum 2" clearance around cooling plenums for proper amplifier cooling.

**DCX 600.4 AND DCX 1000.4 FRONT PLATE DIAGRAM**

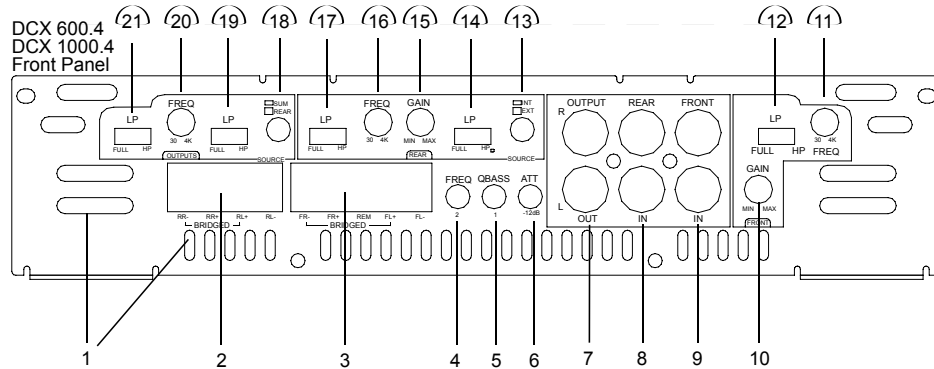

**1. Cooling Plenums:** Maintain a minimum 2" clearance around cooling plenums for proper amplifier cooling.

**2. Rear Speaker Connector:** Plug in the **PowerLock™** connector here.

**3. Front Speaker/Remote Connector:** Plug in the **PowerLock™** connector here.

**4 & 5. QBASS™ 1 and QBASS™ 2 Freq.:** Use these switches, **QBASS™ 1** and **QBASS™ 2** to program the **QBASS PLUS™** circuit frequency.

**6. -12dB Attenuation Switch:** Push this switch 'IN' for high voltage input (4V-12V) capability. This button must be pushed 'IN' for use with speaker level input on common ground head-units or for high voltage line drivers.

**7. RCA Output:** RCA outputs provide HP/LP/FULL 30-4kHz signal to another amplifier.

**8. Rear Inputs:** Plug in the rear RCA leads from your source here.

**9. Front Inputs:** Plug in the front RCA leads from your source input here.

**10. Front Gain:** Use this control to match the output level of the source unit to the front channel of the amplifier.

**11. Front Freq. Control:** Move this detented control in a clockwise direction to adjust the front crossover frequency from 30Hz to 4kHz.

**12. Front HP/LP/FULL Switch:** Select the desired crossover



setting. HP/LP/FULL for the speaker output signal of the front channel.

**13. Rear Source INT/EXT Switch:** Select the INT position (switch in) if you want to use the internal signal path from the front crossover for the rear input, or the EXT position (switch out) to use the external rear RCA input.

**14. Rear HP/LP/FULL Switch:** Select the desired setting. HP/LP/FULL for the internal signal from the front channel to the rear channel when not using an external rear RCA input.

**15. Rear Gain:** Use this control to match the output level of the head unit to the rear channel of the amplifier.

**16. Rear Freq. Control:** Move this detented control in a clockwise rotation to adjust the rear crossover frequency from 30Hz to 4kHz.

**17. Rear HP/LP/FULL Switch:** Select the desired crossover setting, HP/LP/FULL for the speaker output signal of the rear channel.

**18. Source Sum/Rear Switch:** Select the SUM (switch in position) if you want to use the RCA output information summed from the front and rear audio channels. Select the REAR (switch out position) to select the input off of the rear channel, providing bandpass capability.

**19. Output Source HP/LP/FULL Switch:** Select the desired crossover setting, HP/LP/FULL for the RCA output signal.

**20. Output Crossover Freq. Control:** Use this control to adjust the output crossover frequency from 30Hz to 4kHz.

**21. Output Crossover HP/LP/FULL Switch:** Select the desired crossover setting, HP/LP/FULL for the internal output signal of the RCA output.

**Note:** See the next section for the rear panel view of this endplate.

## DCX 800.5 FRONT PLATE DIAGRAM

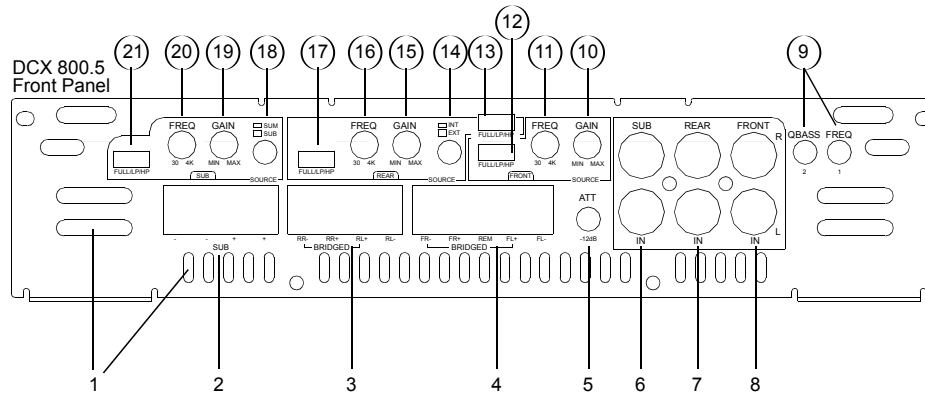

- 1. Cooling Plenums:** Maintain a minimum 2" clearance around cooling plenums for proper amplifier cooling.
- 2. Sub Speaker Connector:** Plug in the *PowerLock™* connector here.
- 3. Rear Speaker Connector:** Plug in the *PowerLock™* connector here.
- 4. Front Speaker/Remote Connector:** Plug in the *PowerLock™* connector here.
- 5. -12dB Attenuation Switch:** Push this switch 'IN' for high voltage input (4V-12V) capability. This button must be pushed 'IN' for use with speaker level input on common ground head-units or for high voltage line drivers.
- 6. Sub Input:** Plug in the front RCA leads from your source unit here.
- 7. Rear Inputs:** Plug in the rear RCA leads from your source here.
- 8. Front Inputs:** Plug in the front RCA leads from your source input here.
- 9. QBASS™ 1 and QBASS™ 2 Freq.:** Use these switches, *QBASS™ 1* and *QBASS™ 2* to program the *QBASS PLUS™* circuit frequency.
- 10. Front Gain:** Use this control to match the output level of the source unit to the front channel of the amplifier.
- 11. Front Freq. Control:** Move this detented control in a clockwise direction to adjust the front crossover frequency from 30Hz to 4kHz.

**12. Front HP/LP/FULL Switch:** Select the desired crossover setting. HP/LP/FULL for the speaker output signal of the front channel.

**13. Rear Input INT/EXT Switch:** Select the INT position if you want to use the internal signal path from the front crossover for the rear input, or the EXT position to use the external rear RCA input.

**14. Rear Source INT/EXT Switch:** Select the INT position (switch in) if you want to use the internal signal path from the front crossover for the rear input, or the EXT position (switch out) to use the external rear RCA input.

**15. Rear Gain:** Use this control to match the output level of the head unit to the rear channel of the amplifier.

**16. Rear Freq. Control:** Move this detented control in a clockwise rotation to adjust the rear crossover frequency from 30Hz to 4kHz.

**17. Rear HP/LP/FULL Switch:** Select the desired crossover setting, HP/LP/FULL for the speaker output signal of the rear channel.

**18. Sub Source INT/EXT Switch:** Select the INT position if you want to use the internal signal path from the rear crossover for the sub input, or the EXT position to use the external sub RCA input.

**19. Sub Gain:** Use this control to match the output level of the head unit to the sub channel of the amplifier.

**20. Sub Freq. Control:** Use this control to adjust the sub high pass crossover frequency from 30Hz to 4kHz.

**21. Sub HP/LP/FULL Switch:** Select the desired crossover setting, HP/LP/FULL for the internal output signal of the sub channel to the speaker output.

## DCX 600.4, DCX 800.5, DCX 1000.4 END PLATE DIAGRAM

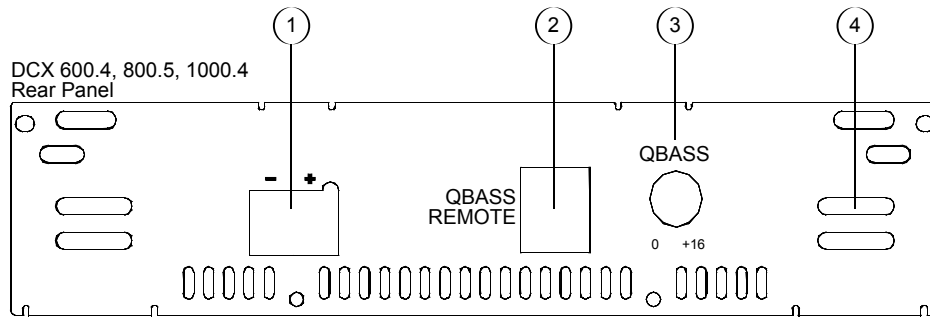

- 1. Power/Ground PowerLock™:** After you have securely connected your power and ground wires, plug in the Power/Ground PowerLock™ connector here.
- 2. QBASS REMOTE™:** Plug in the data cable from the optional QBASS REMOTE™ dash mounted level control here. (The remote level control will bypass the amplifier's on board QBASS™ control.)
- 3. QBASS PLUS™:** Up to 18dB of bass level control boost.
- 4. Cooling Plenums:** Maintain a minimum 2" clearance around cooling plenums for proper amplifier cooling.

## INPUTS

There are two sets of RCA jacks on the front end of your amplifier. The RCA cables from your source unit go in the set labeled INPUTS. If your source unit doesn't have RCA outputs, then add a set of RCA plugs (available at your dealer) to your front or rear set of speaker leads (see drawing below). Plug them into the input jacks, and push in the **-12dB** input attenuation switch.

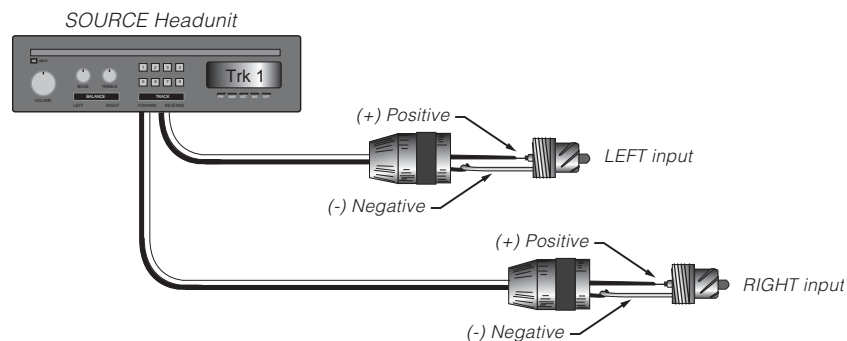

# DCX 300.4, 600.4, 1000.4 BLOCK DIAGRAM

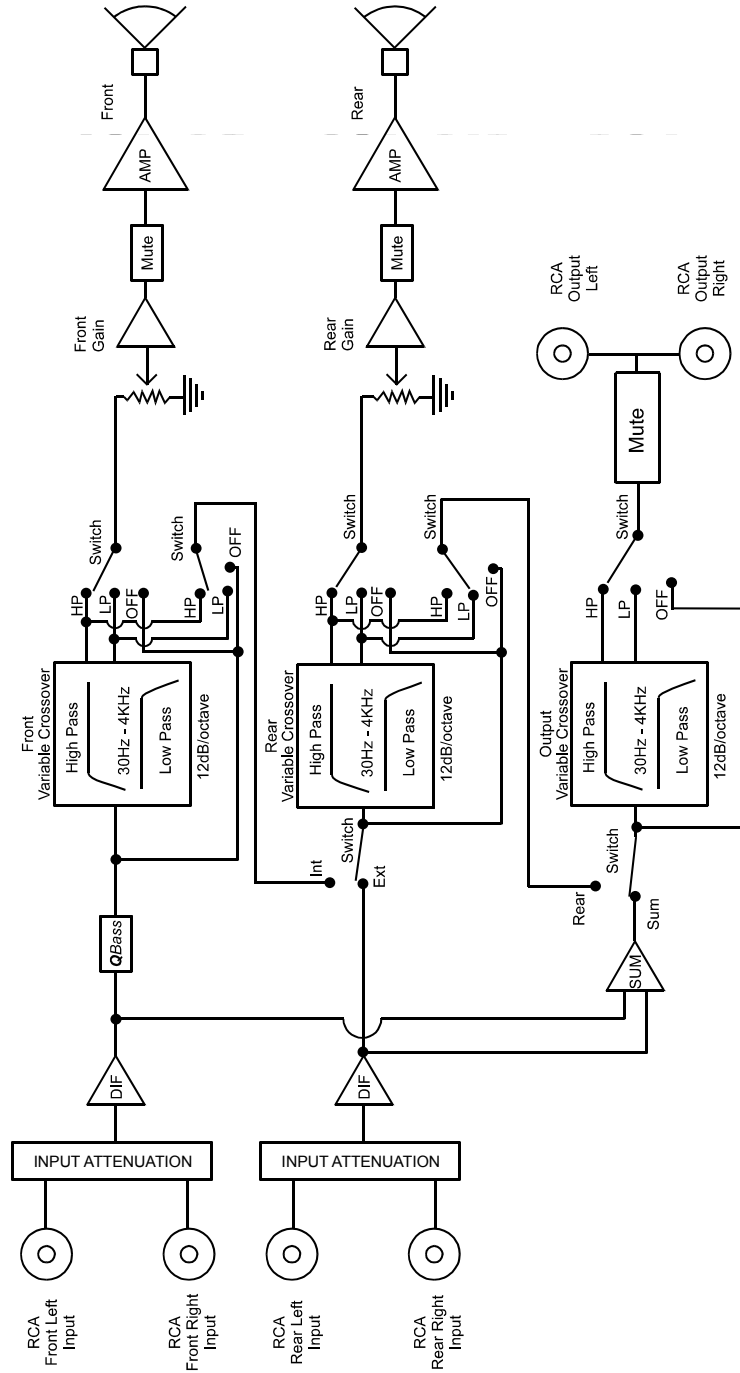

# DCX 800.5 BLOCK DIAGRAM

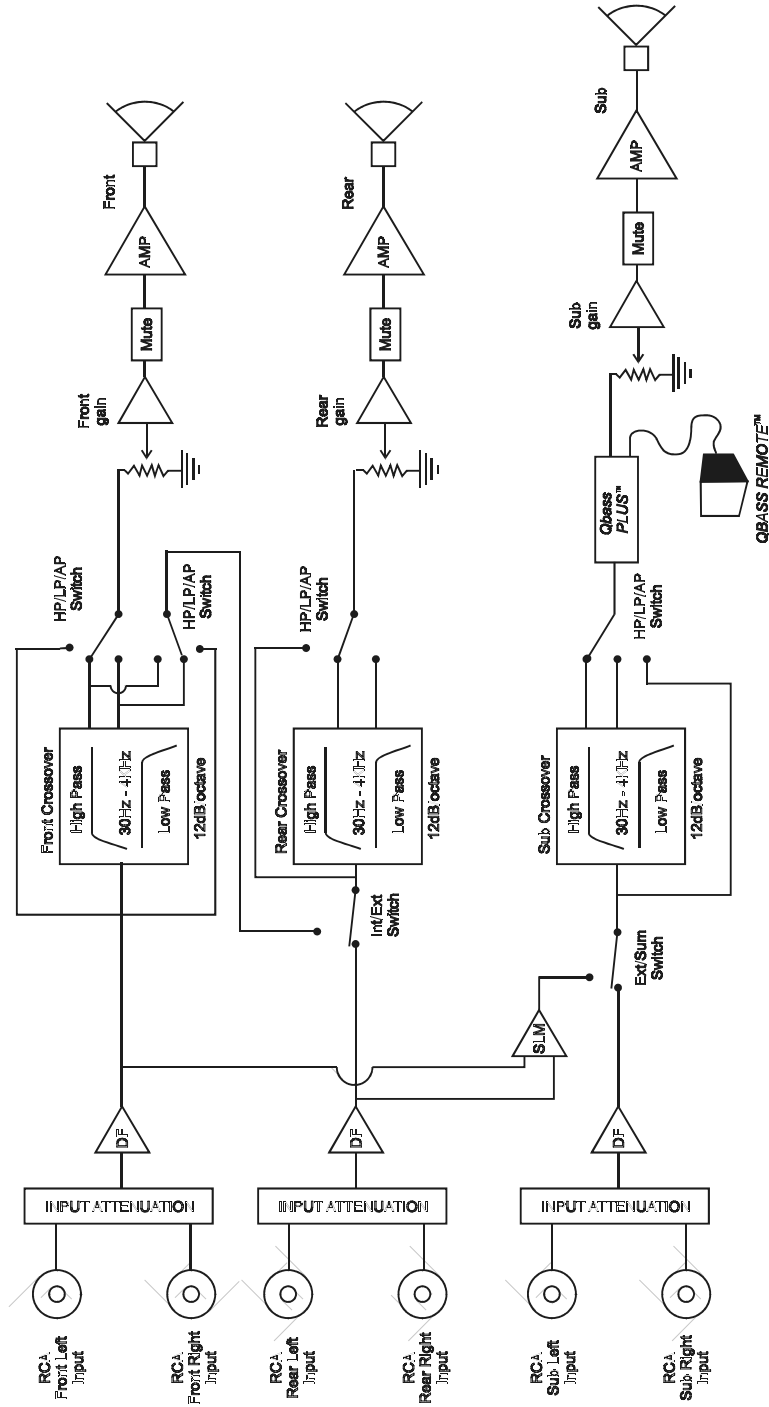

## ADVANCED INSTRUMENTATION INPUT

The Advanced Instrumentation Input has been incorporated from the legendary *PrecisionPower™ 2500F1*. This circuit completely isolates the chassis ground from the audio circuit of the amplifier and reduces noise radiated into your signal cables by up to 40dB. This is equivalent to a noise reduction of approximately one hundred times what the noise level would be without this circuitry. It provides all the benefits of a true balanced line without the need of any special cables (see diagram below). This type of input works with any conventional RCA cables.

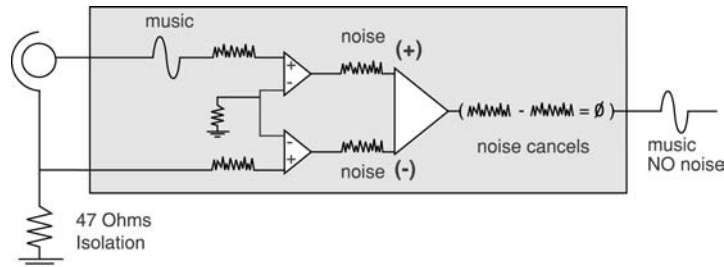

## QBASS

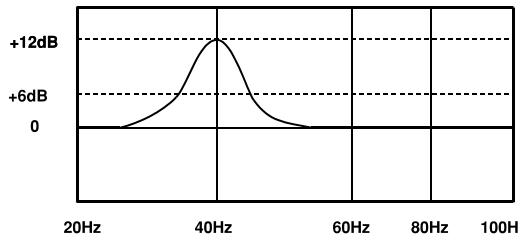

For extra BOOM from your system, we've developed the **QBASS™** bass control circuit. The **QBASS™** control is located on the end plate panel, and allows you to add up to 18dB of boost centered at 40Hz by rotating the control clockwise.

## QBASS PLUS

On **DCX 600.4**, **DCX 800.5**, and **DCX 1000.4** amplifiers, we've taken bass control to a higher level with **QBASS PLUS™**. The two **QBASS™** switches (labeled 1 and 2) on the front end of the amplifier allow you to select one of four frequency centers 30Hz, 36Hz, 44Hz and 60Hz. On the rear end plate you will find the **QBASS™** level control and plug-in for an optional **QBASS REMOTE™** dash mounted level control. Adjust the level control clockwise for up to +18dB of boost at your selected frequency.

QBASS™ Settings		
1	2	Freq.
IN	IN	30Hz
IN	OUT	36Hz
OUT	IN	44Hz
OUT	OUT	60Hz

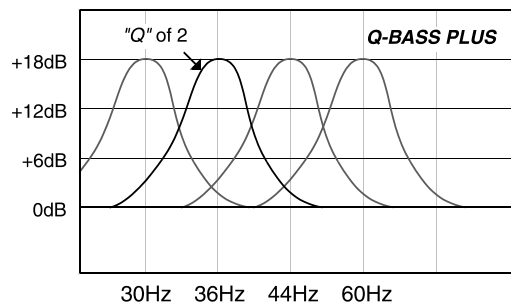

**CAUTION: QBASS PLUS™** should only be used in systems with a strong subwoofer section. +18dB is a tremendous amount of bass boost and may damage your speakers or create excessive distortion if abused.

The optional **QBASS REMOTE™**: This boost control can be mounted in the dash and will supersede the boost control on the endplate.

The **PrecisionPower DCX™** amplifiers no longer need an optional **QPORT™** to connect multiple **QBASS PLUS™** equipped amplifiers while using one **QBASS REMOTE™**. The new **QBASS PLUS™** circuitry in the **DCX** amplifiers is now positioned before the crossover circuit. In doing this, **PrecisionPower™** engineers have allowed you to daisy chain your RCA output to the next amplifier input, causing the first amplifier's **QBASS REMOTE™** to become the master control amplifier. See your authorized **PrecisionPower™** dealer for more information!

## TC-X CROSSOVER



Your new **DCX** amplifier has a **TC-X** Crossover (Total Control X-over®) 30Hz-4kHz (see this guide for Crossover Chart).12dB per octave phase correlated crossover built-in to provide superior system flexibility without the added expense and installation of an outboard crossover. The speaker outputs of your amplifier are high pass, low pass, or all-pass according to the HP/LP/FULL switch on the front endplate. You would choose low pass (middle position of switch) to use this amplifier for subwoofers, choose high pass (left position of switch), or full (right position of switch) to use this amplifier for full range speakers.

The RCA outputs are controlled by a separate HP/LP/FULL switch, and are always independent of the speaker output crossover. As well as being able to independently select HP/LP/FULL, your new **DCX** amplifier allows independent selection of frequencies from 30Hz-4kHz (see Crossover Detent Chart in this guide).

#### ***DCX 300.4/600.4/1000.4***

**Front** - 12dB/Octave, Detented High Pass 30Hz-4kHz  
**Rear** - 12dB/Octave, Detented High Pass; HP/LP/FULL

**RCA Outputs** - 12dB/Octave, Detented High Pass; HP/LP/FULL  
**QBASS PLUS™** - on Rear Channel - up to 18dB @ 30, 36, 44, 60Hz

#### ***DCX 800.5***

**Front** - 12dB/Octave, Detented High Pass 30Hz-4kHz  
**Rear** - 12dB/Octave, Detented High Pass; HP/LP/FULL

**RCA Outputs** - 12dB/Octave, Detented; HP/LP/FULL  
**Sub-Summed Stereo** - 12dB/Octave Detented; 30Hz-4kHz;  
HP/LP/FULL  
**QBASS PLUS™** - on Sub Channel - up to 18dB @ 30, 36, 44, 60Hz

## CROSSOVER DETENT CHART

---

Detent #	Low Pass Frequency (Hz) @ -3dB	High Pass Frequency (Hz) @ -3dB
1	28	52
2	28	52
3	30	52
4	30	56
5	30	56
6	32	60
7	34	64
8	36	72
9	38	76
10	42	80
11	46	88
12	50	92
13	52	100
14	54	116
15	60	132
16	66	148
17	76	168
18	88	192
19	100	216
20	116	244
21	136	284
22	144	348
23	168	404
24	198	468
25	240	512
26	286	564
27	310	624
28	340	700
29	380	800
30	424	932
31	484	1036
32	576	1144
33	632	1300
34	748	1504
35	932	1812
36	1076	2196
37	1428	2840
38	1700	4116
39	2436	4540
40	2830	4728
41	2980	4728

## **INPUT COMBINE**

---

Your multi-channel **DCX** amplifier can use both front and rear outputs from your head unit to maintain the ability to fade front to rear, or you can run a single set of RCAs to the front inputs and push in the Rear Input INT/EXT switch on the amplifier endplate to route the front signal to the rear channels as well.

## **ADJUSTING INPUT GAIN**

---

1. Adjust all amplifier input gain controls to just above minimum sensitivity (fully counterclockwise).
2. Using the cleanest music source (CD) playing, turn up the head unit source volume until you can hear distortion. Now turn it down a bit until you cannot hear the distortion (usually just below full volume).
3. Increase the amplifier gain (clockwise) until the onset of audible distortion. Then decrease the gain to the point just before the distortion starts. This setting minimizes background noise and prevents overload.
4. Repeat step 3 for any remaining independently controlled amplifiers (rear and subwoofer gain controls) in the system.

## **HIGH MASS INTERNAL HEATSINK**

---

The unique heatsink on your **DCX** amplifier has been designed with fins on the inside of the aluminum extrusion. This allows for the transfer of heat from the circuitry to the heatsink fins and out through the vents in the endplates. Be sure you provide ample space around the amplifier for cooling: at least 2" on all sides.

## **FORCED AIR THERMAL MANAGEMENT**

---

To manage the additional heat associated with higher output capability, a thermally controlled fan has been designed into the **DCX 1000.4**. When the heatsink temperature reaches a pre-determined value, the fan is activated and cool air is drawn in

through the lower intake vents on the endplate. This cool air flows below the circuit board, through the fan and across the internal fins, cooling the heatsink. The warm air is then forced out through the upper end-plate exhaust vents.

#### **AP-IV PROTECTION CIRCUIT**

---

Short Circuit Protection engaged: The **DCX** amplifiers will turn off and try to come back on immediately (the Short RED LED will illuminate). The amplifier will cycle like this indefinitely with “blips” of sound each time. If this is the case, check your speakers and wiring for low impedance and short circuits.

Thermal Protection engaged. The **DCX** amplifiers will turn off and after a minute or so will come back on (the Thermal RED LED will illuminate). In this case, ensure that there is nothing blocking the normal convection airflow of the amplifier. No obstruction should be within 2” of the amplifier on all sides.

**Note: Low battery voltage will cause the amplifier to run warmer and possibly damage the amplifier.**

## **TROUBLESHOOTING**

---

NO SOUND Is the LED illuminated?

**YES**

**NO**

Check Power and Remote  
turn-on wire for voltage.  
Make sure the ground wire  
is secure.

STILL NO SOUND

See your Authorized *PrecisionPower™* Dealer or call 1-800-62POWER.

SOUND IN ONE CHANNEL ONLY

Reverse the left and right speakers by unplugging the speaker connector,  
turning it over and plugging it back in.

SOUND IS NOW IN

**OPPOSITE CHANNEL**

Reverse RCA inputs.

**SAME CHANNEL**

Problem is in the speaker or  
speaker wire of the silent  
channel.

SOUND IS NOW IN

**OPPOSITE CHANNEL**

Reverse RCA inputs  
at head unit.

**SAME CHANNEL**

Problem is in the amplifier.  
See your local Authorized  
PrecisionPower Dealer or  
call 1-800-62POWER.

SOUND IS NOW IN

**OPPOSITE CHANNEL**

Problem is in the head  
unit or before the amplifier.

**SAME CHANNEL**

Problem is in the RCA  
cables.

## LIMITED TWO YEAR CONSUMER WARRANTY:

Directed Electronics, Inc. promises to the original purchaser, to replace this product should it prove to be defective in workmanship or material under normal use, for a period of two years from the date of purchase by the dealer as indicated by the date code marking of the product PROVIDED the product was installed by an authorized Directed dealer. During this two-year period, there will be no charge for this replacement PROVIDED the unit is returned to Directed, shipping pre-paid. If the unit is installed by anyone other than an authorized Directed dealer, the warranty period will be 1 year from the date of purchase by the dealer as indicated by the date code marking of the product. During this 1-year period there will be no charge for this replacement PROVIDED the unit is returned to Directed, shipping pre-paid. This warranty is non-transferable and does not apply to any unit that has been modified or used in a manner contrary to its intended purpose, and does not cover damage to the unit caused by installation or removal of the unit. This warranty is void if the product has been damaged by accident or unreasonable use, neglect, improper service or other causes not arising out of defects in materials or construction. ALL WARRANTIES INCLUDING BUT NOT LIMITED TO EXPRESS WARRANTY, IMPLIED WARRANTY, WARRANTY OF MERCHANTABILITY, FITNESS FOR PARTICULAR PURPOSE, AND WARRANTY OF NON-INFRINGEMENT OF INTELLECTUAL PROPERTY ARE EXPRESSLY EXCLUDED TO THE MAXIMUM EXTENT ALLOWED BY LAW, AND DIRECTED NEITHER ASSUMES NOR AUTHORIZES ANY PERSON TO ASSUME FOR IT ANY LIABILITY IN CONNECTION WITH THE SALE OF THE PRODUCT. DIRECTED HAS ABSOLUTELY NO LIABILITY FOR ANY AND ALL ACTS OF THIRD PARTIES INCLUDING ITS AUTHORIZED DEALERS OR INSTALLERS. Unit must be returned to Directed, postage pre-paid, with: consumer's name, telephone number, and address, authorized dealer's name and address, and product description. IN ORDER FOR THIS WARRANTY TO BE VALID, YOUR UNIT MUST BE SHIPPED WITH PROOF OF INSTALLATION BY AN AUTHORIZED DIRECTED DEALER. ALL UNITS RECEIVED BY DIRECTED FOR WARRANTY REPAIR WITHOUT PROOF OF DIRECTED DEALER INSTALLATION WILL BE COVERED BY THE LIMITED 1-YEAR PARTS AND LABOR WARRANTY. Note: This warranty does not cover labor costs for the removal and reinstallation of the unit. BY PURCHASING THIS PRODUCT, THE CONSUMER AGREES AND CONSENTS THAT ALL DISPUTES BETWEEN THE CONSUMER AND Directed SHALL BE RESOLVED IN ACCORDANCE WITH CALIFORNIA LAWS IN SAN DIEGO COUNTY, CALIFORNIA.



## Free Manuals Download Website

<http://myh66.com>

<http://usermanuals.us>

<http://www.somanuals.com>

<http://www.4manuals.cc>

<http://www.manual-lib.com>

<http://www.404manual.com>

<http://www.luxmanual.com>

<http://aubethermostatmanual.com>

Golf course search by state

<http://golfingnear.com>

Email search by domain

<http://emailbydomain.com>

Auto manuals search

<http://auto.somanuals.com>

TV manuals search

<http://tv.somanuals.com>