

Assembly Guide

CW-119

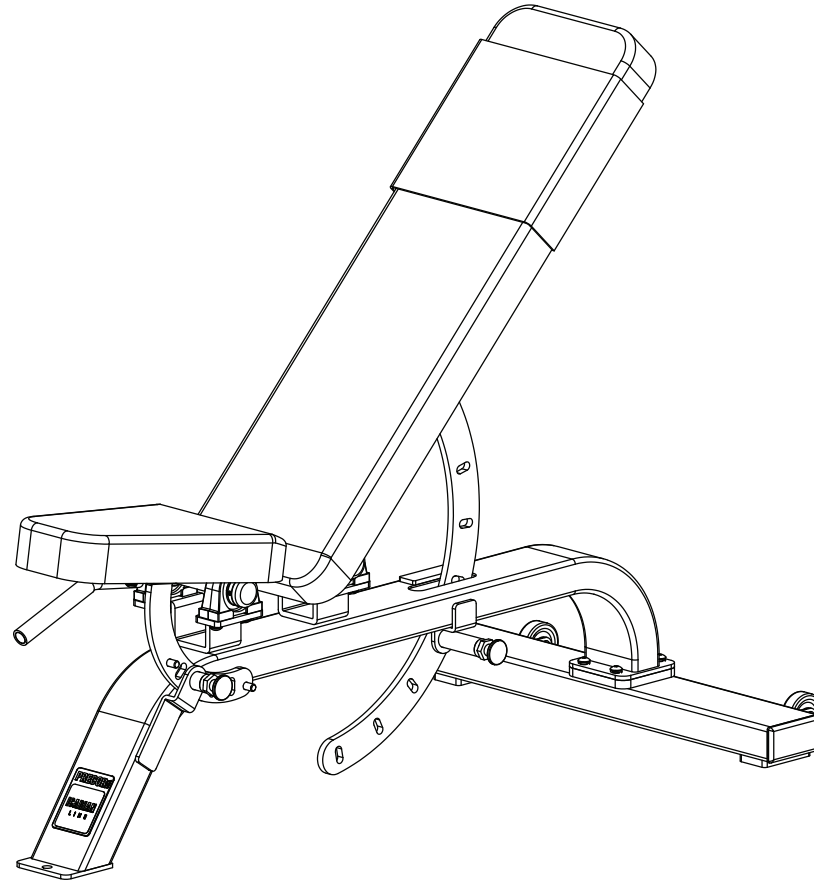

PRECOR USA 

Important Safety Instructions

When using exercise equipment, basic precautions should always be taken, including the following:

- Read all instructions before assembling the CW-119. These instructions are written for your safety and to protect the unit.
- Read each step in the assembly instructions and follow the steps in sequence. Do not skip ahead. If you skip ahead, you may learn later that you have to disassemble components and that you may have damaged the equipment, which would void the Precor Limited Warranty.
- Assemble and operate the CW-119 on a solid, level surface. Locate the unit a few feet from walls or furniture to provide easy access.
- Do not allow children or those unfamiliar with its operation on or near the equipment. Do not leave children unsupervised around the unit.
- Use the equipment only for its intended purpose. Do not use accessory attachments that are not recommended by the manufacturer, as such attachments may cause injuries.
- Do not attempt to service the CW-119 yourself. The unit does not contain any user-serviceable parts.

Obtaining Service

For information about product operation or service, refer to the Precor web site at www.precor.com where you can also find customer support numbers or a list of Precor authorized service centers.

If you contact Customer Support, have the serial number available.

You can find the serial number printed on a label affixed to the CW-119. For future reference, write the serial number in the space provided below.

Serial number: _____

Table of Contents

	Important Safety Instructions	3
	Obtaining Service	3
1	Preparations	5
	Unpacking the Equipment	5
	Required Tools	5
	Installation Requirements	5
	Hardware Kit	6
2	Assembly Instructions	7
	Open the Box	7
	Assemble the Unit	8
	Assemble the Pads	9
	Clean the Pads and Assembly	10
	Limited Warranty Statement	11
	Specifications	Back cover

1

Preparations

The CW-119 parts are inspected before shipment. Each unit contains several pieces that require assembly. You must obtain adult assistance during the assembly process.

Unpacking the Equipment

When you open the box, carefully unpack the pieces and lay them on the floor near the location where you plan to use them.

CAUTION: Be careful when you remove the packaging material with a utility knife. Do not cut the upholstery or scratch the paint.

If any items are missing, contact the dealer from whom you purchased the unit. For more information, refer to *Obtaining Service*.

Required Tools

Tools that you need to obtain before assembling the unit include:





- Wire cutter or utility knife
- SAE hex key set

Installation Requirements

Follow these installation requirements when assembling the unit:

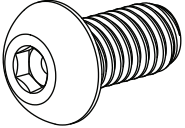
- **Review the *Important Safety Instructions*.**
- **Assemble the unit where it will be used.**
Provide ample space around the unit.
- **Install components in the sequence shown.**
- **Insert all fasteners in the same direction.**
For aesthetic purposes, insert all the fasteners in the same direction unless instructed (in text or illustrations) to do otherwise.
- **Leave room for adjustments.** Tighten the fasteners to keep the unit stable, but leave room for adjustments. Do not fully tighten fasteners until instructed to do so.

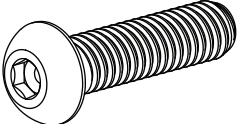
Hardware Kit

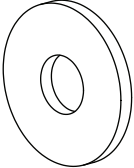
Fastener		Qty
	<p>3/8-inch x 3/4-inch buttonhead screw (A)</p>	<p>4</p>
	<p>3/8-inch split washer (B)</p>	<p>4</p>
	<p>5/16-inch x 1 1/4-inch buttonhead screw (C)</p>	<p>7</p>
	<p>5/16-inch split washer (D)</p>	<p>7</p>
	<p>5/16-inch washer (E)</p>	<p>7</p>

2

Assembly Instructions

Assembly of the CW-119 takes about 45 minutes to complete. If this is the first time you have assembled this type of equipment, plan on allowing more time.

Be careful to open boxes and assemble components in the sequence presented in this manual.

Note: With so many assembled parts, proper alignment and adjustment is critical. While tightening the fasteners, be sure to leave room for adjustments. **Do not fully tighten fasteners until instructed to do so.**

Open the Box

Use wire cutters to open the box and remove the packing materials.

The illustration shows how the CW-119 will look when you have completed its assembly. The callouts identify specific pieces.

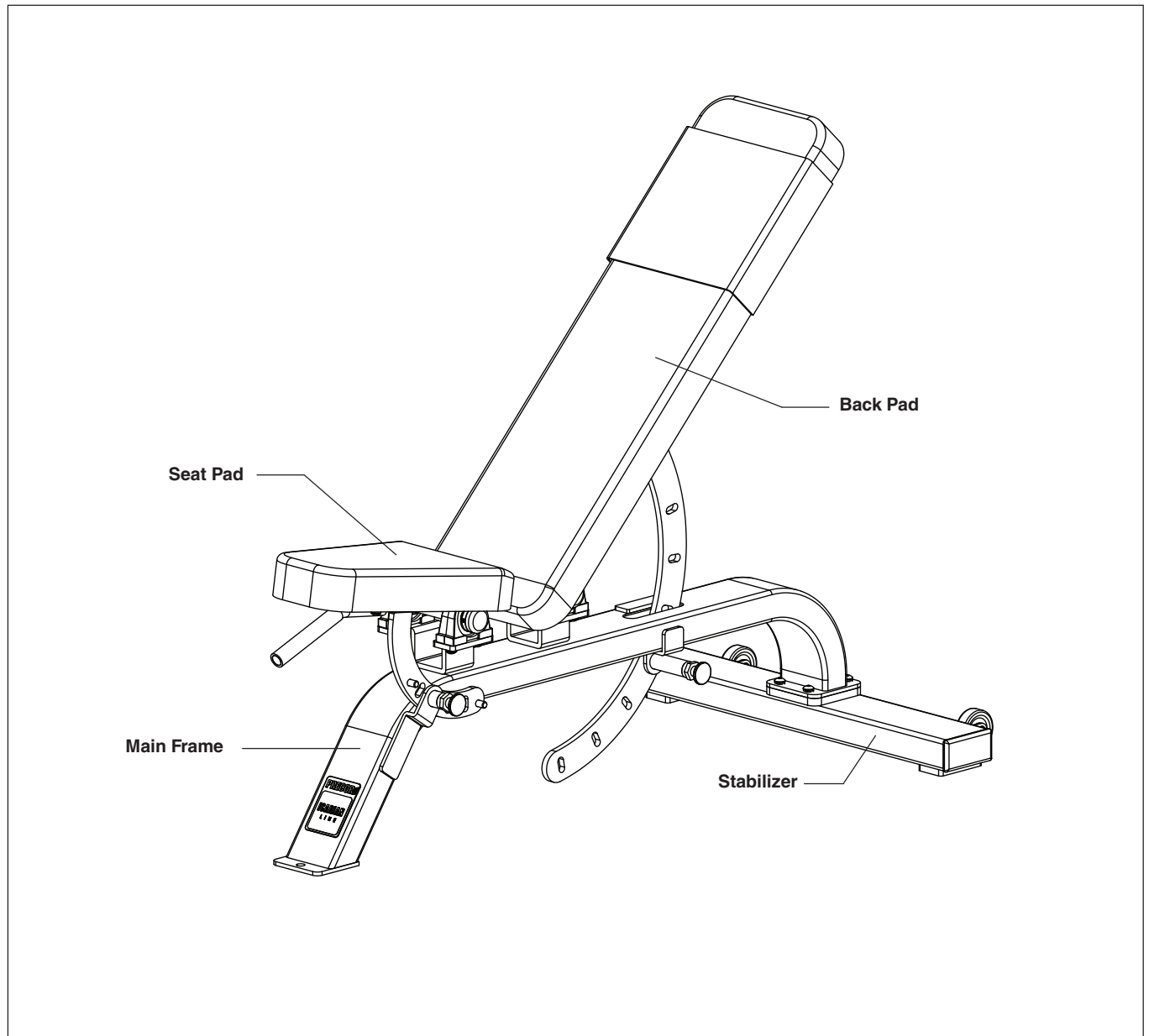

Assemble the Unit

Attach the Main Frame to the Stabilizer using
four $\frac{3}{8}$ -inch X $\frac{3}{4}$ -inch buttonhead screws (A)
four $\frac{3}{8}$ -inch split washers (B)
Wrench tighten.

Note: Make sure the wheels on the Stabilizer are
positioned as shown in the illustration.

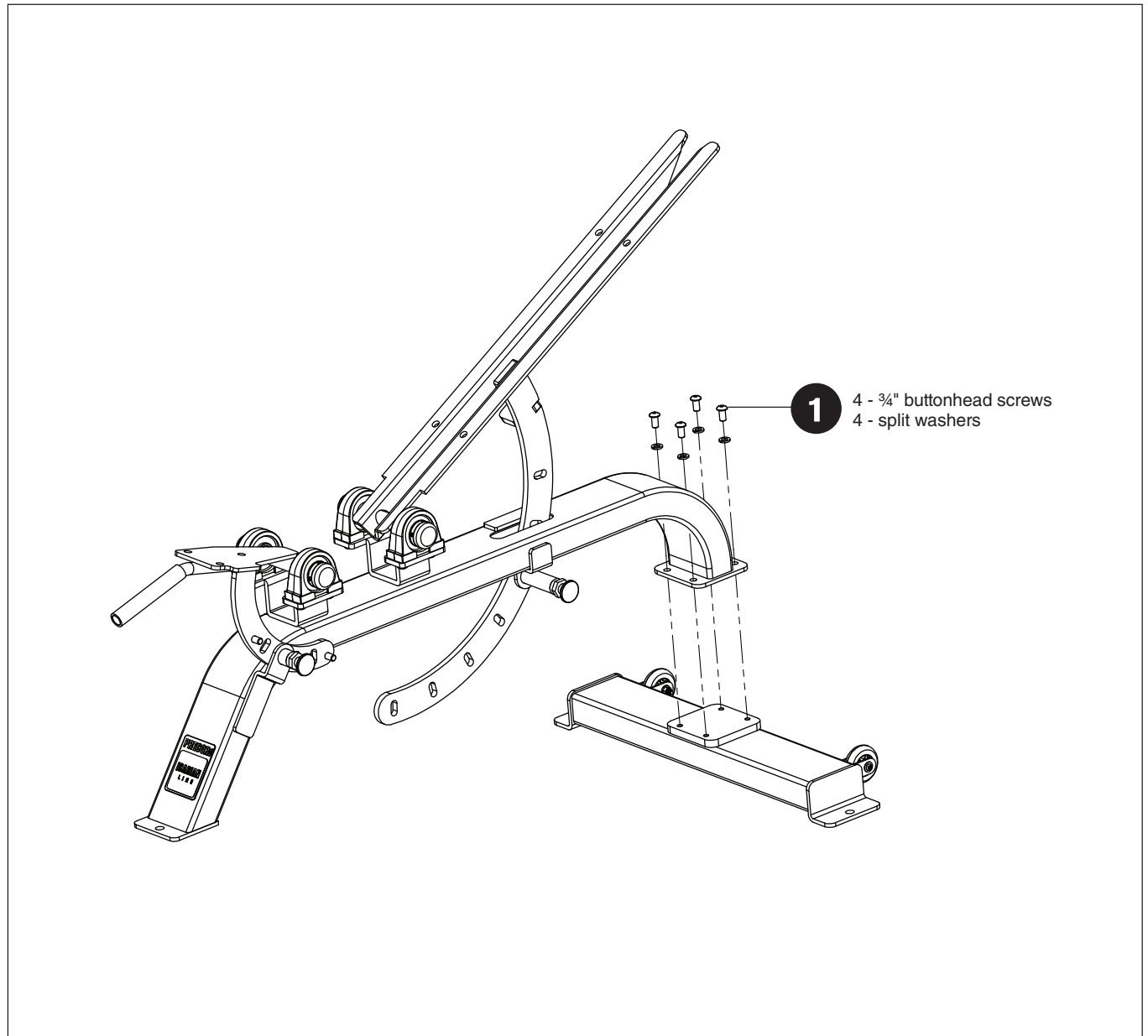

Assemble the Unit

Assemble the Pads

1. Attach the Seat Pad to the Seat Adjustment using three 1¼-inch buttonhead screws (C) three ⅝-inch split washers (D) three ⅝-inch washers (E) Wrench tighten.
2. Attach the Back Pad to the Back Adjustment using four 1¼-inch buttonhead screws (C) four ⅝-inch split washers (D) four ⅝-inch washers (E) Wrench tighten.

This completes the assembly of the CW-119.

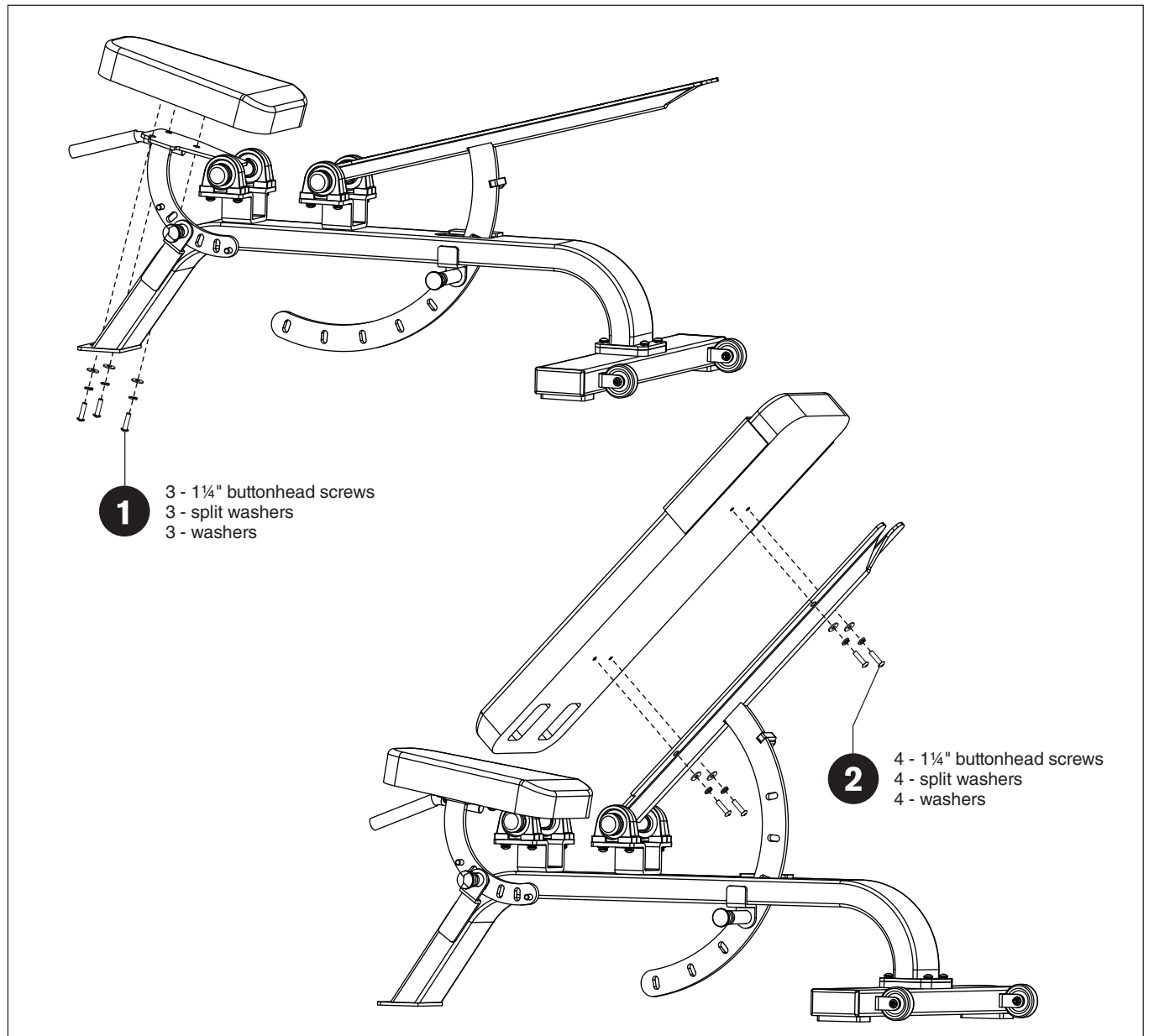

Assemble the Pads

Clean the Pads and Assembly

To clean the pads, moisten a clean, soft cloth in a mild solution of soap and water and wipe all the parts thoroughly. Dry the pad with a clean, dry cloth.

Use the same procedure to clean the Main Frame and plastic parts.

Frequently vacuum the floor underneath the CW-119 to prevent the accumulation of dust and dirt. If necessary, use the Seat Pad to lift the front end and tip the CW-119 onto its wheels to roll it to a different location.

Clean the Pads and Assembly

Limited Warranty

Precor, Incorporated (PRECOR) will repair or replace any of the following components which are defective as to materials or workmanship for products manufactured and sold after June 1, 1990:

ICARIAN & STRETCH CENTER:

Lifetime: Structural Steel Framework

Five Years: Rotary Bearings, Weight Stacks, Pulleys, Guide Rods, Structural Moving Parts

One Year: Cable, Linear Bearings, Springs

Ninety Days: Upholstery, Handgrips, All Other Items Not Listed

Notwithstanding the above, all warranties provided by PRECOR shall terminate upon transfer of ownership of the equipment by the original owner. PRECOR may require the Customer to affirm that he is the original owner of the equipment before providing warranty services. This warranty does not extend to any components which become defective due to abuse, misuse, or lack of proper maintenance or if the equipment under warranty has been modified or altered in anyway. The Customer seeking repair or replacement of defective equipment must notify PRECOR at the address set forth on the back cover of such defect, admit PRECOR authorized service representatives during normal business hours to effect repairs and pre-pay all defective equipment within thirty (30) days of its receipt of notice of the defect from a Customer or the equipment itself.

THIS WARRANTY IS LIMITED TO REPAIR AND/OR REPLACEMENT OF DEFECTIVE EQUIPMENT. Except to the extent it is precluded from doing so in a particular state or other jurisdiction by applicable law. PRECOR DISCLAIMS ANY AND ALL OTHER WARRANTIES WHETHER EXPRESSED OR IMPLIED, INCLUDING BUT NOT LIMITED TO ANY IMPLIED WARRANTY OR MERCHANTABILITY OR FITNESS FOR A PARTICULAR PURPOSE.

Moreover, if any damage or defect is caused by the transport carrier, such claims must be filed with the carrier at the time of delivery. PRECOR DISCLAIMS ANY AND ALL RESPONSIBILITY FOR SUCH DAMAGE OR DEFECT, NO DEALER, EMPLOYEE, SALES REPRESENTATIVE OR AGENT HAS ANY AUTHORITY TO MAKE ANY WARRANTIES OR REPRESENTATIONS CONCERNING PRECOR EQUIPMENT BEYOND THOSE SET FORTH IN THIS WARRANTY AND IN OTHER OFFICIAL PRECOR LITERATURE: AND PRECOR DISCLAIMS ALL RESPONSIBILITY FOR ANY SUCH UNAUTHORIZED WARRANTIES OR REPRESENTATIONS.

An individual purchasing PRECOR equipment in California for personal, family or household purposes has the right to have defective equipment serviced or repaired during the warranty period. The warranty period will be extended for the number of whole days that the equipment is out of the buyer's hands for warranty repairs. If a defect exists within the warranty period, the warranty will not expire until the defect has been fixed. The warranty period will also be extended if the warranty repairs have not been performed due to delays caused by circumstances beyond the control of the buyer, or if the warranty repairs did not remedy the defect and the buyer notifies PRECOR or its authorized dealer or sales representative of the failure of the repairs within sixty (60) days after they were completed. If after a reasonable number of attempts, the defect has not been fixed, the buyer may return the equipment for a replacement or a refund subject, in either case, to deduction of a reasonable charge for usage. This time extension does not affect the protections or remedies the buyer has under other laws. Purchasers of PRECOR strength equipment have the right to bring an action at law or in equity to resolve disputes concerning or to enforce the provisions of this warranty. Some states do not allow the exclusion of limitations of incidental or consequential damages and/or limitation on how long an implied warranty lasts, so the above limitations or exclusions may not apply to all Customers. This warranty gives Customers specific legal rights; Customers may also have other rights which may vary from state to state.

Notes:

CW-119 Specifications

Length: 48 inches (122 cm)

Height: 39 inches (99 cm)

Width: 30 inches (76 cm)

Shipping weight: 84 lb (38 kg)



Precor Incorporated
20031 142nd Avenue NE
P.O. Box 7202
Woodinville, WA USA 98072-4002
1-800-347-4404

Precor, Icarian, and Move Beyond are registered trademarks of Precor Incorporated.

Copyright 2008 Precor Incorporated.

Specifications subject to change without notice.

www.precor.com

NOTICE:

Precor is widely recognized for its innovative, award winning designs of exercise equipment. Precor aggressively seeks U.S. and foreign patents for both the mechanical construction and the visual aspects of its product design. Any party contemplating the use of Precor's product designs is hereby forewarned that Precor considers the unauthorized appropriation of its proprietary rights to be a very serious matter. Precor will vigorously pursue all unauthorized appropriation of its proprietary rights.

CW-119 Assembly Guide CW33677-102
Limited Warranty Statement CW31973-102
16 September 2008

Free Manuals Download Website

<http://myh66.com>

<http://usermanuals.us>

<http://www.somanuals.com>

<http://www.4manuals.cc>

<http://www.manual-lib.com>

<http://www.404manual.com>

<http://www.luxmanual.com>

<http://aubethermostatmanual.com>

Golf course search by state

<http://golfingnear.com>

Email search by domain

<http://emailbydomain.com>

Auto manuals search

<http://auto.somanuals.com>

TV manuals search

<http://tv.somanuals.com>