

## Shoulder Press User's Guide

### Important Safety Guidelines

**Caution:** Before using the equipment, read these instructions and all labels. Failure to do so may result in serious injury.

- Do not allow children, or those unfamiliar with the operation of this unit, on or near it.
- Before beginning any fitness program, see your physician for a thorough physical examination. Ask your physician for the appropriate target heart rate for your age and fitness level.
- If you feel pain, faintness, or dizziness, **stop exercising immediately**.

### Specifications

**Machine Dimensions** 65" L x 52" W x 67" H (165 cm L x 132 cm W x 170 cm H)

**Working Area** 65" L x 52" W (165 cm L x 132 cm W)

**Weight Stack** 215 lb (98 kg)

**Machine Weight** 600 lb (272 kg)

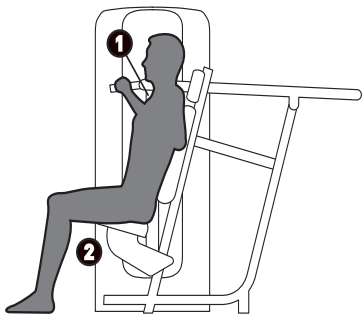

### Setup

1. Select an appropriate weight.
2. Adjust the seat height so the handles are slightly above your shoulders.

### Exercise

- Grasp both handles.
- Extend your arms in a slow, controlled motion while keeping your back firmly against the pad.
- Pause at full extension.
- Slowly return to the start position.

### Training Tips

- Avoid locking your elbows.

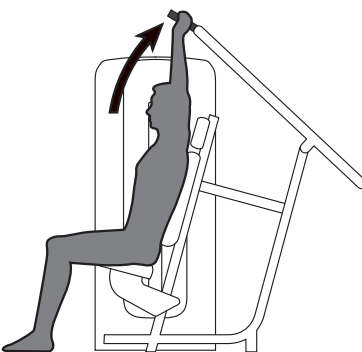

**PRECOR®**

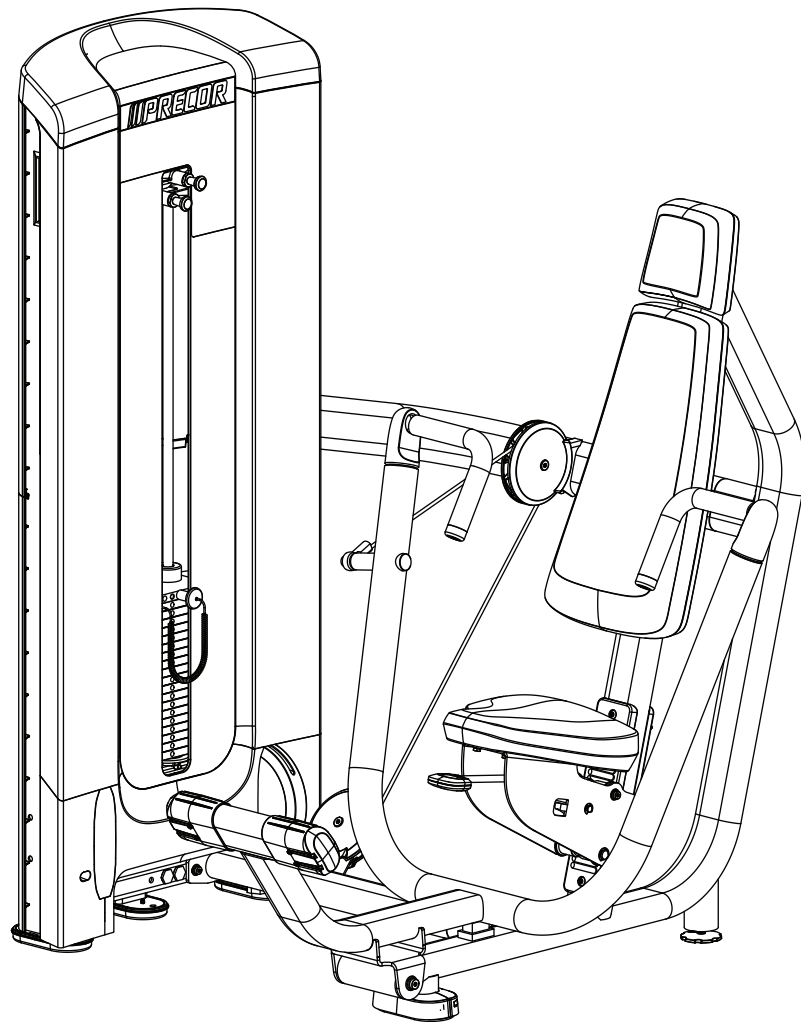

# Owner's Manual

Experience Strength™ C-Line



# Important Safety Guidelines for Owners

Follow these guidelines to maintain proper working condition of the equipment:

**Important:** Do not modify the equipment or any of its parts, or permanently remove any part from the equipment. Do not use accessory attachments that are not recommended by Precor, as such attachments might cause injuries.

- Regular maintenance must be performed by qualified technicians.
- Make sure that trainers, facility personnel, and maintenance technicians understand how to use the equipment, know important safety guidelines, and can recognize potential problems such as a worn cable or cracked weld.
- Strength training requires a significant focus by the facility and its staff to maintain the quality of the fitness environment. The facility should provide direct supervision of the fitness equipment at all times by people knowledgeable about the safe operation of the equipment and trained to recognize potential problems.
- If any facility personnel witness unsafe use of the equipment, the staff member should address the user directly, demonstrate the proper technique, and review the *Important Safety Information for Users*. Precor recommends posting a copy of the Important Safety Information for Users near the equipment in a prominent location.
- Make sure the equipment is stable and placed on a solid, level surface. The equipment is designed to be freestanding; however, equipment can be bolted to the floor for extra stability. Consult a qualified general contractor for proper fastening methods.
- Make sure that the equipment is installed with enough free space for safe operation. With most equipment, the general rule is to allow about a 4-foot (1.2 meters) circle of space from the user's center. For Functional Training equipment, make sure that the operating space is large enough to allow the cables to be fully extended in all possible directions.
- Check the equipment thoroughly based on the recommended inspection schedules outlined in this manual, including daily, weekly, monthly and annual checks.

- Place an "out-of-order" sign on the equipment during maintenance of the equipment or the surrounding area. Users should never be allowed to operate the equipment until it has been inspected and works properly. If a piece of equipment needs service, keep it out of use until repaired. Place an "out-of-order" sign on the equipment and make sure the facility's personnel know not to allow anyone to use the equipment until it is working properly.
- When working with the weight stacks, do not attempt to free any jammed assemblies alone as this may cause injury. With the help of another person, carefully return the weight stack to the proper position with the top plate resting on the first weight.
- Do not allow the equipment to be used if the top plate or weight stack is pinned in a raised position. With the help of another person, carefully return the machine to the proper position with the top plate resting on the first weight. Inspect the cable to make sure that it is seated in all of the pulleys.
- Whenever a weight can drop and hit a user, such as with an Olympic bench, Precor highly recommends that a helper or spotter be used.
- Do not place the equipment outdoors or on wet surfaces.

## Safety Approval

Certain Precor commercial strength equipment is Class S/B, C certified according to EN957 -1/2 standards. See an authorized Precor dealer for a complete and current listing of certified machines.

# Important Safety Information for Users

Before beginning any fitness program, you should obtain a complete physical examination from your physician.

*Il est conseillé de subir un examen médical complet avant d'entreprendre tout programme d'exercice. Si vous avez des étourdissements ou des faiblesses, arrêtez les exercices immédiatement.*

When using exercise equipment, you should always take basic precautions, including the following:

- If you do not understand how to operate a piece of equipment, ask someone from the facility such as a trainer to demonstrate how to use it and explain any safety instructions.
- Do not allow children on or near the equipment. Do not leave children unsupervised around the equipment.
- Use the equipment only for its intended purpose. Do not use accessory attachments that are not recommended by the manufacturer, as such attachments may cause injuries.
- Wear proper exercise clothing and shoes for your workout—no loose clothing.
- **Do not overexert yourself or work to exhaustion.** Use reasonable judgment when working with weights. Avoid using excessive weight, which may cause injury.
- If you feel pain or abnormal symptoms, stop exercising immediately and consult your physician.
- Keep head, limbs, fingers, and hair clear of all moving parts while the equipment is in use. Keep hands clear of racking pegs.
- Never drop or insert objects into any opening in the equipment.
- Always check the equipment before using it. If you spot a potential problem, contact someone in the facility immediately. Do not use the equipment until the facility has verified that the equipment is working properly. Do not attempt to fix a broken or jammed machine.
- Do not use the equipment outdoors or on wet surfaces.
- Do not drop or slam the weight stack while exercising.
- Be sure the selector pin is completely inserted. Use only the pin provided by the manufacturer. If unsure, contact someone in the facility.
- Never pin the weights in an elevated position. Do not use the equipment if the top plate or weight stack is pinned in a raised position. Notify the facility's personnel to repair the equipment and ensure that it is working properly.
- Do not use the equipment if an "out of order" sign has been placed on it.
- Read all posted instructions, including all safety instructions and warnings.

# Table of Contents

<b>Important Safety Guidelines for Owners .....</b>	<b>1</b>	<b>Annual Maintenance .....</b>	<b>17</b>
Safety Approval .....	1	Weight Stack Annual Maintenance .....	17
<b>Important Safety Information for Users .....</b>	<b>2</b>	Inspect and Lubricate Pop Pins .....	17
<b>Before You Begin .....</b>	<b>4</b>	<b>Commercial Strength Equipment Limited Warranty .....</b>	<b>18</b>
Recommended Tools .....	4		
Shroud Removal .....	5		
Obtaining Service .....	6		
<b>Daily Inspection .....</b>	<b>7</b>		
Clean Upholstery .....	7		
Inspect Pads for Wear .....	7		
Clean and Inspect Frames .....	7		
Inspect Cables and End Connections .....	8		
Check Warning and Instructional Labels .....	9		
<b>Weekly Inspection .....</b>	<b>11</b>		
Condition and Deep Clean Upholstery .....	11		
Clean and Lubricate Cable Rod Ends .....	11		
Clean and Lubricate Guide Rods .....	12		
Inspect Cables, Connections, and Tension .....	12		
Inspect Pulleys .....	13		
Inspect Weight Stack and Selector Pin .....	13		
Inspect and Lubricate Bearings and Bushings .....	13		
Check and Lubricate Seat Adjustment .....	14		
<b>Monthly Inspection .....</b>	<b>15</b>		
Inspect Frames and Movement Arms .....	15		
Lubricate Pop Pins .....	16		
Inspect All Fasteners .....	16		

# Before You Begin

Precor recommends implementing a thorough maintenance program that incorporates regular safety inspections by qualified maintenance technicians as outlined in this manual.

This manual explains how to maintain the Precor Experience Strength lines of commercial strength equipment. It provides information about items that need to be inspected and maintained on a daily, weekly, monthly, and annual basis. You should perform those tasks that are appropriate for the equipment you are maintaining, and skip those tasks that do not apply.

This manual covers the general maintenance procedures that you can perform in the fitness facility. However, if the equipment requires service beyond the maintenance procedures covered in this manual, refer to *Obtaining Service*.

**Important:** Always purchase replacement parts and hardware from Precor. Many parts are tested and manufactured specifically for Precor commercial strength equipment. If you use parts not approved by Precor, you could void the Precor Limited Warranty. Use of parts not approved by Precor may cause injury.

Precor recommends that maintenance technicians thoroughly read and understand the safety guidelines and maintenance procedures covered in this manual.

**Note:** If the equipment requires assembly, a separate assembly guide is provided. For information on how to use a piece of equipment, refer to the instructional label found on the equipment.

## Recommended Tools

We recommend that you keep the following tools available to inspect and maintain the equipment:

- Complete combination box wrench set from 1/2-inch to 15/16-inch
- Complete socket set from 1/2-inch to 15/16-inch
- Hex nut driver: 1/4-inch
- Adjustable 12-inch crescent wrench
- Complete hex key set from 5/64-inch to 3/8-inch
- Rubber mallet

# Shroud Removal

The Experience Strength product line includes a shroud that must be removed to perform the maintenance described in this manual.

**Important:** Do not remove the shroud while the equipment is in use.

Use the following instructions to remove the shroud:

1. Grasp the back of the Top Cover with both hands near the middle.
2. Apply upward pressure to remove the Top Cover.

**Note:** It may help to use your palms to push forward on the top of the Upper Back Shroud while pushing up on the Top Cover.

3. Pull the Upper Back Shroud up and away from the unit to remove it.

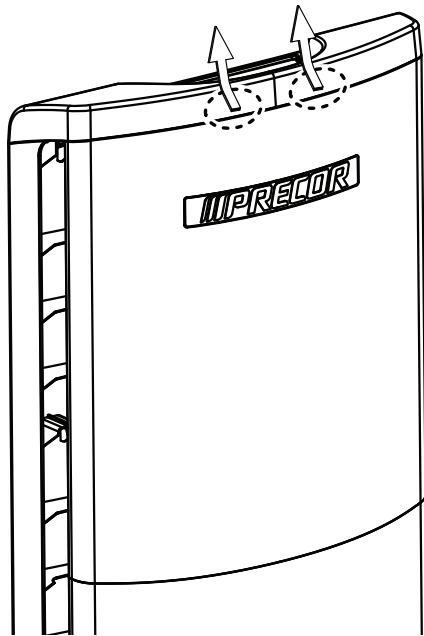

Figure 1: Removing the Top Cover

Perform the necessary maintenance. When you are finished, replace the shroud.

1. Attach the Upper Back Shroud first, aligning the tabs at the bottom with the Lower Back Shroud.

**Note:** Make sure the clips at the top of the Upper Back Shroud snap securely to the Weight Stack Frame.

2. Attach the Top Cover, making sure that it snaps securely into place.



## Obtaining Service

You should not attempt to service the strength equipment, except for the maintenance tasks described in this manual. If any items are missing, contact your dealer. If you need more information regarding customer support numbers or a list of Precor authorized service centers, visit the Precor website at [www.precor.com](http://www.precor.com).

If you have any questions regarding a piece of equipment, locate its serial number and contact Precor Customer Support. Precor uses the serial number to establish the model and year of the product. You can generally find the serial number underneath the seat support.

For future reference, write the serial numbers, model numbers, and dates of purchase for your Precor strength training equipment in the space provided. You may want to list all equipment information below for easy reference.

Model #: \_\_\_\_\_ Serial #: \_\_\_\_\_

Date purchased: \_\_\_\_\_

Model #: \_\_\_\_\_ Serial #: \_\_\_\_\_

Date purchased: \_\_\_\_\_

Model #: \_\_\_\_\_ Serial #: \_\_\_\_\_

Date purchased: \_\_\_\_\_

Model #: \_\_\_\_\_ Serial #: \_\_\_\_\_

Date purchased: \_\_\_\_\_

Model #: \_\_\_\_\_ Serial #: \_\_\_\_\_

Date purchased: \_\_\_\_\_

Model #: \_\_\_\_\_ Serial #: \_\_\_\_\_

Date purchased: \_\_\_\_\_

Model #: \_\_\_\_\_ Serial #: \_\_\_\_\_

Date purchased: \_\_\_\_\_

Model #: \_\_\_\_\_ Serial #: \_\_\_\_\_

Date purchased: \_\_\_\_\_

Model #: \_\_\_\_\_ Serial #: \_\_\_\_\_

Date purchased: \_\_\_\_\_

Model #: \_\_\_\_\_ Serial #: \_\_\_\_\_

Date purchased: \_\_\_\_\_

Model #: \_\_\_\_\_ Serial #: \_\_\_\_\_

Date purchased: \_\_\_\_\_

# Daily Inspection

You will need to perform the following tasks each day to maintain the equipment and keep it operating smoothly:

- Clean any upholstery on the equipment.
- Inspect pads for wear.
- Clean and inspect equipment frames.
- Inspect cables and end connections for wear.
- Check warning and instructional labels.

Perform the tasks that are appropriate for the equipment you are maintaining, and skip the tasks that do not apply.

## Clean Upholstery

To remove surface dirt and perspiration, clean upholstery daily with a mild soap and water solution in a spray bottle. Spray upholstered surfaces lightly and wipe them dry with a clean cloth.

**Important:** To clean the upholstery, do not use cleaning products that have any of these ingredients: solvents, alcohol, ammonia, or petroleum. Use a mild detergent-based cleaner instead.

## Inspect Pads for Wear

Inspect pads for cracks in the upholstery, loose staples, and loose mounting bolts. Replace pads as needed (refer to *Obtaining Service* to purchase new pads).

**Important:** Do not reupholster pads or use pads not approved by Precor.

## Clean and Inspect Frames

To remove grease and dirt, clean frames daily with a mild soap and water solution in a spray bottle. Wipe the equipment down with a damp cloth and dry completely. Be sure to wipe down both painted parts and chrome parts.

To restore and maintain the luster of chrome parts, use a commercial chrome cleaner.

As you clean, inspect the frames for cracks, rust, or other damage. Make sure welds are solid and fasteners are properly secured.

# Inspect Cables and End Connections

**CAUTION:** Carefully inspect the cables, pulleys, fasteners, and related hardware regularly. Replace any cable at the first sign of wear using only Precor-supplied replacement parts. With regular use, a cable can become worn and might fail. Sudden failure of a worn cable can cause severe injury to a user. Refer to *Obtaining Service* to purchase replacement parts.

Inspect the cables and end connections each day, and replace if damaged. Check for kinks, frayed wires, deterioration of the cable coating, and broken thimbles. Look for signs of wear particularly at crimped ends of the cable and near pulleys.

**Important:** Cables must be replaced immediately if they are damaged to avoid possible injury to users.

Some obvious signs of cable damage are as follows:

- 1 Exposed inner wire, stretching or cuts in the coating, or broken coating in the area that passes over a pulley
- 2 A zigzag or wavy pattern
- 3 Kinks, which may indicate internal damage
- 4 A necked-down cover
- 5 A “ballooned” cover

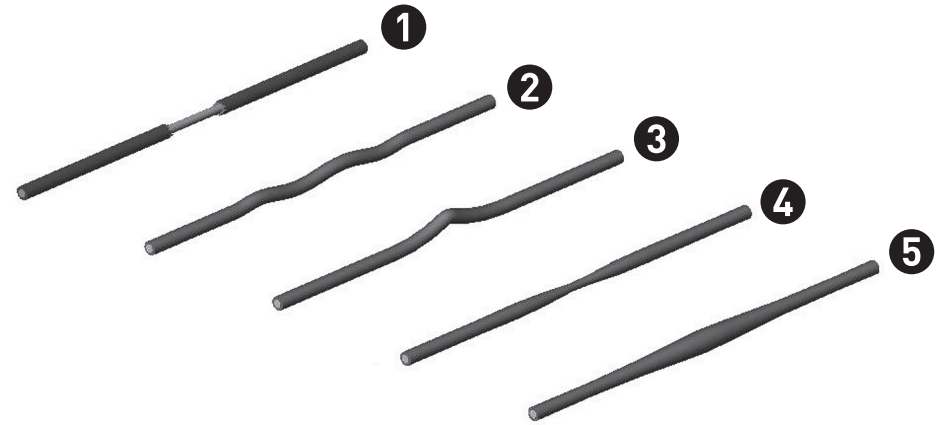

**Figure 2: Signs of cable damage**

In addition to inspecting the cables and end connections for damage, check the following:

- Make sure that each cable is properly adjusted and tightened at the top of the weight stack.
- Check cable pulleys, end connections, and end fittings. Make sure all connections are tight, adjusting cable tension as necessary.
- Make sure that the cable bolt is threaded a minimum of ten threads into the selector stem, and the locking jam nut is tight. (Refer to the following figure.)

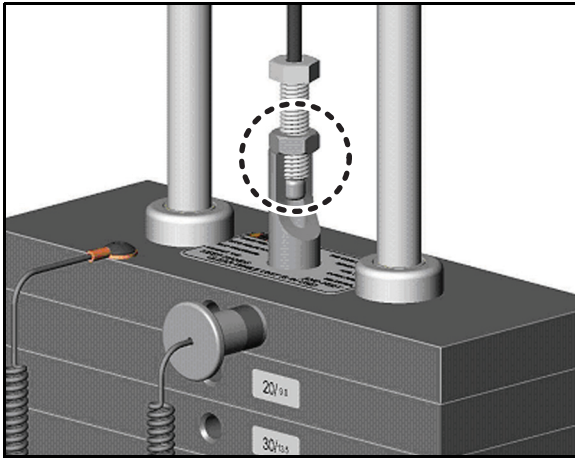

**Figure 3: Cable bolt must have a minimum of ten threads into the selector stem**

## Check Warning and Instructional Labels

Inspect warning and instructional labels daily to make sure that all the information can be clearly read. If any portion is not visible or part of the label is not adhered properly, replace that label immediately (refer to *Obtaining Service* for purchase information).

Clean labels as needed with a mild soap and water solution in a spray bottle, and dry thoroughly with a soft cloth.

The following figure shows an example of a user instructional label.

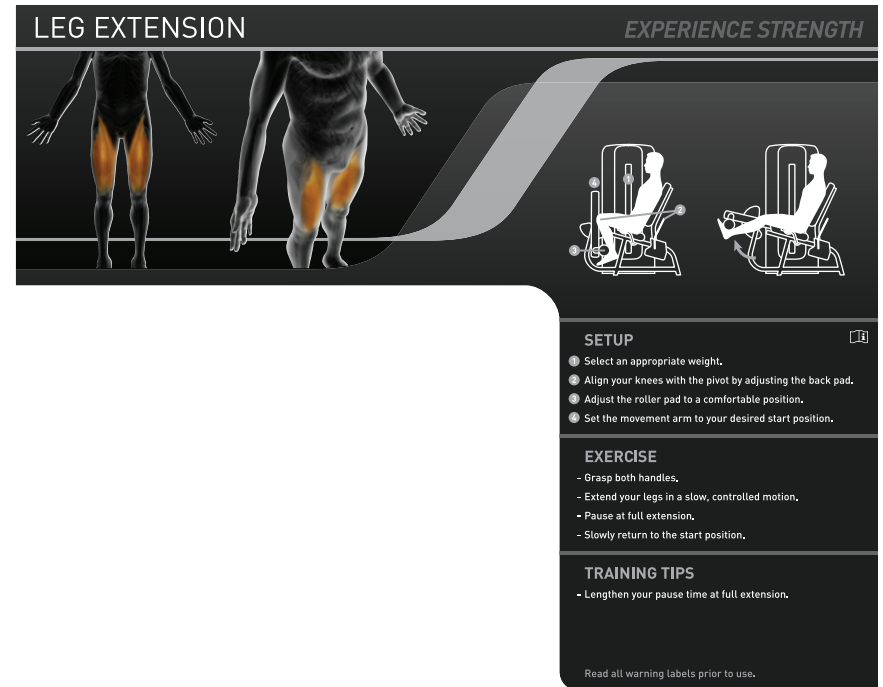

**Figure 4: Sample user instructional label for the Experience Strength C-Line**

Precor products come equipped with a number of standard warning labels. The following two figures show sample warning labels you may see on the equipment depending on the model and product line:

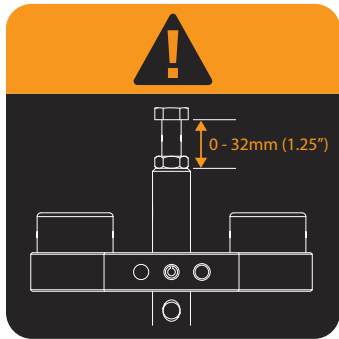

**Figure 5:** A warning label may appear on or near weight stacks where a cable bolt is threaded into the selector stem

## **Warning**

**Improper use of this equipment can result in serious injury. Even with proper use, you assume a risk of injury when using this type of equipment.**

- Before beginning a fitness program, see your physician for a thorough physical examination.
- Do not allow children on or near this equipment.
- Before using this equipment, read and follow all warnings and safety instructions.
- Inspect the equipment prior to use. Check for loose fasteners or frayed cables. If you suspect the equipment may be in need of service, notify the facility staff.
- Use the equipment only for its intended use. Obtain proper instruction.
- Make sure the selector pin is fully engaged.
- If weights, pulleys, or other parts become jammed, do not attempt to free them, as weights may fall unexpectedly. Notify the facility staff.
- Do not remove labels from the equipment. Replace labels if they become damaged or lost.

**Figure 6:** A version of this warning label appears on the equipment frame

# Weekly Inspection

This section covers the tasks you should perform each week to maintain the equipment. Perform the following tasks as appropriate for the unit you are maintaining:

- Condition and deep clean upholstery.
- Clean and lubricate cable rod ends.
- Clean and lubricate guide rods.
- Inspect cables, connections, and tension.
- Inspect cable handle attachments.
- Inspect pulleys.
- Inspect each weight stack and selector pin.
- Inspect and lubricate bearings and bushings.
- Check seat adjustment and test pop pins.

## Condition and Deep Clean Upholstery

Condition and deep clean the upholstery weekly with a lanolin-based hand cleaner or upholstery cleaner.

**Important:** To clean the upholstery, do not use cleaning products that have any of these ingredients: solvents, alcohol, ammonia, or petroleum. Use a mild detergent-based cleaner instead.

## Clean and Lubricate Cable Rod Ends

Check cable rod ends to make sure the shoulder bolts are secure. If cable rod ends are noisy, lubricate them with a silicone spray lubricant. Spray the lubricant onto the joint where the spherical portion is enclosed in the outer housing, as shown in the following figure. Wipe off any excess lubricant with a cloth.

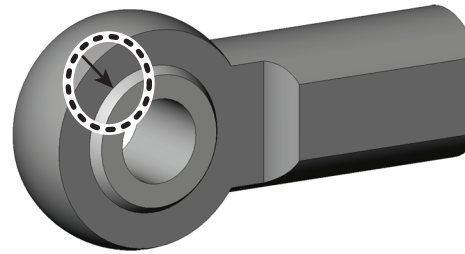

**Figure 7:** Lubricate cable rod ends with silicone spray lubricant

**Important:** Do not use petroleum-based lubricants.

## Clean and Lubricate Guide Rods

Inspect the exposed areas of the guide rods for cleanliness. Using a dry cloth, wipe any buildup of dirt or grease from the rods.

**Note:** On the Experience Line of strength equipment, the upper rear shroud must be removed to access the guide rods for inspection, cleaning, and lubricating (refer to *Shroud Removal*).

Lubricate the exposed areas of the guide rods by applying a light coat of silicone spray lubricant. Spray the lubricant on a cloth, then wipe the guide rods with the cloth. *Be careful with any lubricant spray; it can stain carpet and clothing.*

**CAUTION: Do not attempt to lubricate the guide rods when the equipment is in use. Attempting to lubricate between the weight plates without completely disassembling the stack will result in serious injury.**

**Important:** *Do not use petroleum-based lubricants. These lubricants tend to cause a rapid buildup of dirt and hair on the weight plates, which can cause the plates to stick together.*

## Inspect Cables, Connections, and Tension

Each week, give the cables and connections a thorough inspection and check cable tensions. The following lists the specific things you need to inspect:

- Check the cable termination at the weight stack. For most equipment, the exposed shank can be no more than 1¼ inches (32mm); this distance allows for a minimum of 10 turns of the bolt into the selector stem (refer to *Inspect Cables and End Connections*, earlier). Check and adjust the distance accordingly. *Also make sure that the locking jam nut is tight against the selector stem.*
- Check the cable, especially near all pulley wheels and cams.
- Check the cable as it terminates at the cam, which is stationary on most equipment. Inspect the bolt passing through the cam end fitting to be sure the two jam nuts are tightened against each other. Also, check the entire cable routing to verify that there is no interference with any structure.
- Inspect the ball end of the cable where the cable connection rests in the clevis housing.
- Make sure that each cable is properly adjusted and tightened at the top of the weight stack.
- Check cable pulleys, end connections, and end fittings. Make sure all connections are tight, adjusting cable tension as necessary.

## Inspect Pulleys

Precor uses precision ball bearing idler pulleys to guide the cable smoothly.

Inspect each pulley for damage, including hairline cracks, chips, or missing sections. Worn surfaces in the pulleys can cause severe damage to the cables and must be replaced at the first sign of wear or damage.

Be certain that the wheels turn freely as the equipment is used. Inspect each pulley for excessive side-to-side play, which indicates worn bearings or loose mounting bolts. If excessive play is discovered, remove the pulley to inspect the bearings and replace the entire pulley if necessary.

## Inspect Weight Stack and Selector Pin

Weight stacks are made of precision machined plates that are designed as a single mechanism to stack precisely. Use only Precor-supplied add-on weights and weight selector pins.

On a weekly basis, inspect weight stacks and selector pins. Wipe each plate with a damp cloth as needed. Inspect all plates for sharp burrs or damage. Wipe dirt and dust off the guide rods.

Make sure the equipment uses only the original Precor selector pin. In addition, make sure the selector pin can be fully inserted and retained in each weight plate.

## Inspect and Lubricate Bearings and Bushings

Precor uses high quality bearings designed for strength applications and long service life. Each week, do the following to maintain the bearings and bushings on the equipment:

- **Bronze bushings:** Precor recommends using a small amount of silicone spray lubricant to lubricate these bushings, which usually support rotary shafts. Spray directly onto the shaft, and then rotate the shaft through its complete range of motion several times. Inspect bushings for excessive wear and damage. *Be careful when using the spray lubricant; it can stain carpet and clothing.* Wipe off any excess lubricant with a cloth.
- **Nylon bushings:** Lubricate the nylon bushings on the guide rods by applying a light coat of silicone spray lubricant. Spray the silicone lubricant on a cloth, then wipe the cloth along the full length of the guide rod.
- **Sealed Bearing Pivot Points:** These locations are protected from the outside environment and require no lubrication. While cleaning the equipment, wipe down the shafts and external bearing surfaces with a cloth to prevent the buildup of dust and perspiration.



- **Linear Bearings:** These bearings allow weight plates and other mechanical parts to travel smoothly along guide rods. (Refer to the following figure.) Inspect the ends of each guide rod to make sure they are fastened correctly and all bolts are tight.

*Wipe down guide rods using a light application of a silicone spray lubricant to remove dust, hair, and dirt. Polish the guide rods using fine grade steel wool if surface rust is present.*

**Important:** Do not use petroleum-based lubricants.

*If you lubricate the guide rods regularly, then the bearings will function as designed. Otherwise, the guide rods may corrode. This can cause the bearings to become clogged and jammed, leading to actual gouging of the guide rods. Be sure to remove surface rust and oxidation from the guide rods as soon as you observe it.*

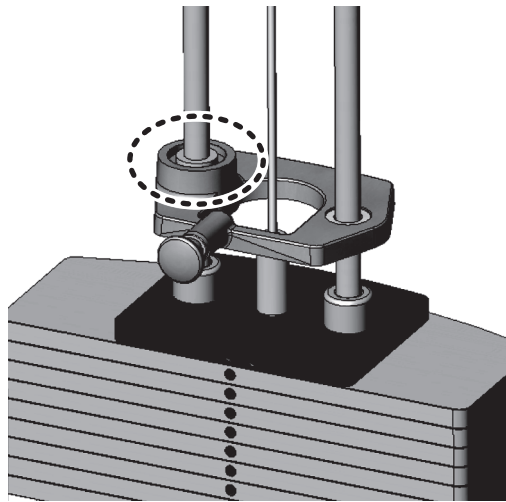

**Figure 8:** Shows a typical location of a linear bearing in its housing

## Check and Lubricate Seat Adjustment

The seat adjustment mechanism requires little maintenance. However, because seat safety is important to the safety of a workout, you should check the ratcheting seat lever regularly to see if it sticks when used.

To test if the seat lever needs lubrication, elevate the seat slightly while pressing and releasing the lever. The lever should snap back out easily. If the lever sticks, lubricate its pivot pin with silicone spray lubricant. Wipe off any excess lubricant with a cloth.

# Monthly Inspection

This section covers the tasks you should perform each month to maintain the equipment. Perform the following tasks as appropriate for the unit you are maintaining:

- Inspect frames and movement arms.
- Lubricate pop pins.
- Check and lubricate ratcheting seat lever.
- Inspect all fasteners.
- Inspect gas shocks for leaks.

## Inspect Frames and Movement Arms

Inspect frames and movement arms monthly for proper function and integrity. Check for cracks, chipped paint, or rust. Touch up dings and chips in the paint as needed. Replace any component at first signs of wear.

**Note:** You can order touch-up paint from Precor by calling Customer Support. Refer to *Obtaining Service*.

Inspect frames for cracks, particularly at the joints. If any cracks are found, take the equipment out of service immediately and have a qualified maintenance technician repair it. Refer to *Important Safety Guidelines for Owners* and *Obtaining Service*.

To remove surface rust from the frame, rub lightly with a fine wet/dry sandpaper or fine steel wool. Finish with Precor touch-up paint if needed. Maintain paint luster with an application of a mild automotive wax product.

To maintain the powder coated and chrome parts, use a mild detergent-based cleaner for light dirt and grime removal. For removing heavier dirt and grease and for polishing, use a good automotive polish. For scuffs and marks that are not removed by the above methods, use a soft scrub cleanser. Do not use solvents, lacquer thinner, acetone, or fingernail polish remover.

## Lubricate Pop Pins

Pull out the pop pin as far as it goes and apply a small amount of silicone spray lubricant. Wipe off any excess lubricant with a cloth. (Refer to the following figure.)

**CAUTION: Pulling out the pop pin may cause the unit to adjust position suddenly. To avoid injury, keep your hands and head away from moving parts.**

Test the pop pin for proper function and engagement in each adjustment hole.

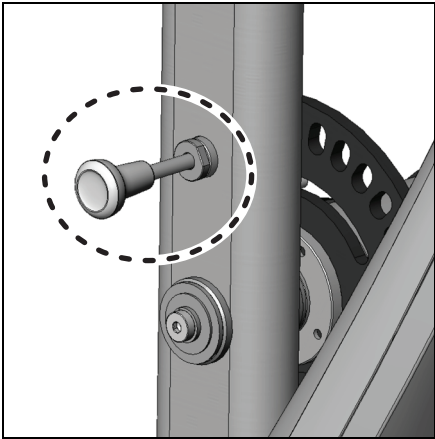

Figure 9: Lubricate the pop pin by pulling it out

## Inspect All Fasteners

Fasteners can loosen with normal use. Inspect all nuts, bolts, screws, and other fasteners to make sure they are tight and installed correctly.

Be sure to check fasteners at bolted joints to make sure the connections are secure. If a fastener is loose but in good condition, retighten it. If you are concerned about the integrity of the fastener, remove it, clean the threads, and inspect it for any damage such as cracks, bad threads, corrosion, or rust. Reinstall the fastener if it appears to be in good condition. Otherwise, remove the equipment from service until a new fastener can be installed properly. You can order new fasteners from Customer Support. For additional information, refer to *Obtaining Service*.

# Annual Maintenance

Perform these tasks on an annual basis, as appropriate for your equipment.

## Weight Stack Annual Maintenance

Once a year, Precor recommends disassembling the weight stack to clean and inspect it thoroughly.

- Carefully remove the cable and guide rods from the weight stack. Completely disassemble the weight stack in a well-ventilated area, away from the exercise floor.
- Inspect weight plates and clean them thoroughly. Cracked or broken plates should be replaced immediately (refer to *Obtaining Service* to purchase replacements). Clean each plate individually and inspect guide bushings.
- Inspect the bushings of the top weight plate and replace the plate if excessively worn or broken.
- Clean the selector stem and inspect it for wear and damage.
- Reassemble the weight stack.
- Wipe down the weight stack enclosures (shrouds) with a damp cloth as needed. Inspect all fasteners to make sure the shroud is securely mounted.

**Important:** Precor recommends that you replace worn and damaged cables during routine maintenance. It is recommended that all cables be replaced annually.

## Inspect and Lubricate Pop Pins

Remove the pop pin assembly by loosening the cap.

**CAUTION:** Pulling out the pop pin may cause the unit to adjust position suddenly. To avoid injury, keep your hands and head away from moving parts.

Inspect the plunger and spring for excessive wear and damage, and replace as required.

Apply a small amount of silicone spray lubricant to the spring and plunger, and then reinstall the entire assembly. Tighten the cap. Wipe off any excess lubricant with a cloth.

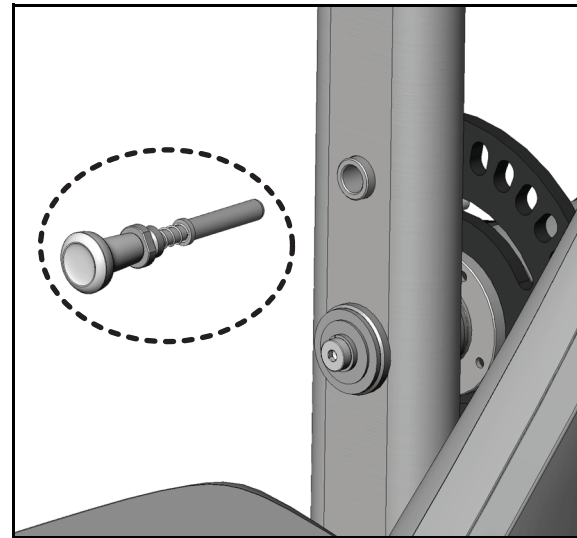

Figure 10: Inspect pop pins (pop pin shown in exploded view for clarity)

# Commercial Strength Equipment Limited Warranty

PLEASE READ THESE WARRANTY TERMS AND CONDITIONS CAREFULLY BEFORE USING YOUR PRECOR INCORPORATED PRODUCT. BY USING THE EQUIPMENT, YOU ARE CONSENTING TO BE BOUND BY THE FOLLOWING WARRANTY TERMS AND CONDITIONS.

## Limited Warranty.

Precor Incorporated warrants all new Precor products to be free from defects in materials and manufacture for the warranty periods set forth below. The warranty periods commence on the invoice date of the original purchase. This warranty applies only against defects discovered within the warranty period and extends only to the original purchaser of the product. Parts repaired or replaced under the terms of this warranty will be warranted for the remainder of the original warranty period only. To claim under this warranty, the buyer must notify Precor or your authorized Precor dealer within 30 days after the date of discovery of any nonconformity and make the affected product available for inspection by Precor or its service representative. Precor's obligations under this warranty are limited as set forth below.

## Warranty Periods and Coverage:

### Commercial Strength Products manufactured and sold after November 1, 2008.

Frame parts and weldments:	10 years
Weight stack plates and components, bearings, bushings, pulleys, seat adjustment:	5 years
Upholstery pads and rollers:	6 months
All other parts (including hand grips, end caps, cables, selector pins, shrouds):	1 year
Labor:	1 year

## Conditions and Restrictions.

This warranty is valid only in accordance with the conditions set forth below:

1. The warranty applies to the Precor product only while
  - a. it remains in the possession of the original purchaser and proof of purchase is demonstrated,
  - b. it has not been subjected to accident, misuse, abuse, improper service, or non-Precor modification,
  - c. claims are made within the warranty period.
2. Certain products are warranted for standard commercial use only (defined as use in non-fee paying clubs or facilities and less than 6 hours daily use). Unapproved use voids the warranty. Current standard commercial strength products include S-Line, S3.45, S3.25.
3. This warranty does not cover damage or equipment failure caused by electrical wiring not in compliance with electrical codes or Precor owner's manual specifications, or failure to provide reasonable and necessary maintenance as outlined in the owner's manual.
4. Except in Canada, Precor does not pay labor outside the United States.
5. Warranties outside the United States and Canada may vary. Please contact your local Dealer for details.

This Limited Warranty shall not apply to:

1. Normal wear and tear, consumables and cosmetic items, including, but not limited to the following: grips, seats, and labels.
2. Repairs performed on Precor equipment missing a serial number or with a serial tag that has been altered or defaced.
3. Service calls to correct installation of the equipment or instruct owners on how to use the equipment.
4. Pickup and delivery involved with repairs.
5. Any labor costs incurred beyond the applicable labor warranty period.

Complete this portion and keep for your records.

Purchased From: \_\_\_\_\_  
*Example: Dealer or store name.*

Phone Number: \_\_\_\_\_  
*Example: Dealer or store telephone number.*

Product/model: \_\_\_\_\_  
*Example: S3.45.*

The serial number is found on the shipping container.

## **Disclaimer and Release.**

The warranties provided herein are the exclusive warranties given by Precor and supersede any prior, contrary or additional representations, whether oral or written. ANY IMPLIED WARRANTIES, INCLUDING THE WARRANTY OF MERCHANTABILITY OR FITNESS FOR A PARTICULAR PURPOSE THAT APPLY TO ANY PARTS DESCRIBED ABOVE ARE LIMITED IN DURATION TO THE PERIODS OF EXPRESS WARRANTIES GIVEN ABOVE FOR THOSE SAME PARTS. PRECOR HEREBY DISCLAIMS AND EXCLUDES THOSE WARRANTIES THEREAFTER. Some States do not allow limitations on how long an implied warranty lasts, so the above limitation may not apply to you. PRECOR ALSO HEREBY DISCLAIMS AND EXCLUDES ALL OTHER OBLIGATIONS OR LIABILITIES, EXPRESS OR IMPLIED, ARISING BY LAW OR OTHERWISE, WITH RESPECT TO ANY NONCONFORMANCE OR DEFECT IN ANY PRODUCT, INCLUDING BUT NOT LIMITED TO: (A) ANY OBLIGATION, LIABILITY, RIGHT, CLAIM OR REMEDY IN TORT, WHETHER OR NOT ARISING FROM THE NEGLIGENCE OF PRECOR OR ITS SUPPLIERS (WHETHER ACTIVE, PASSIVE OR IMPUTED); AND (B) ANY OBLIGATION, LIABILITY, RIGHT, CLAIM OR REMEDY FOR LOSS OF OR DAMAGE TO ANY EQUIPMENT. This disclaimer and release shall apply even if the express warranty set forth above fails of its essential purpose.

## **Exclusive Remedies.**

For any product described above that fails to conform to its warranty, Precor will provide, at their option, one of the following: (1) repair; (2) replacement; or (3) refund of the purchase price. Precor Limited Warranty service may be obtained by contacting the authorized dealer from whom you purchased the item. Precor compensates Servicers for warranty trips within their normal service area to repair commercial equipment at the customer's location. You may be charged a trip charge outside the service area. THESE SHALL BE THE SOLE AND EXCLUSIVE REMEDIES OF THE BUYER FOR ANY BREACH OF WARRANTY.

## **EXCLUSION OF CONSEQUENTIAL AND INCIDENTAL DAMAGES.**

PRECOR AND/OR ITS SUPPLIERS SHALL HAVE NO OBLIGATION OR LIABILITY, WHETHER ARISING IN CONTRACT (INCLUDING WARRANTY), TORT (INCLUDING ACTIVE, PASSIVE, OR IMPUTED NEGLIGENCE AND STRICT LIABILITY), OR OTHERWISE, FOR DAMAGE TO THE EQUIPMENT, PROPERTY DAMAGE, LOSS OF USE, REVENUE OR PROFIT, COST OF CAPITAL, COST OF SUBSTITUTE EQUIPMENT, ADDITIONAL COSTS INCURRED BY BUYER (BY WAY OF CORRECTION OR OTHERWISE) OR ANY OTHER INCIDENTAL, SPECIAL, INDIRECT, OR CONSEQUENTIAL DAMAGES, WHETHER RESULTING FROM NONDELIVERY OR FROM THE USE, MISUSE OR INABILITY TO USE THE PRODUCT. This exclusion applies even if the above warranty fails of its essential purposes and regardless of whether such damages are sought for breach of warranty, breach of contract, negligence, or strict liability in tort or under any other legal theory. Some states do not allow the exclusion or limitation of incidental or consequential damages, so the above limitation may not apply to you.

This warranty gives you specific legal rights, and you may also have other rights, which vary from state to state.

Effective 1 November 2008  
P/N CW31973-103

*Notes:*







Precor Incorporated  
20031 142nd Ave NE  
P.O. Box 7202  
Woodinville, WA USA 98072-4002  
1-800-347-4404

Precor is a registered trademark of Precor Incorporated.  
Copyright 2008 Precor Incorporated.  
Specifications subject to change without notice.  
[www.precor.com](http://www.precor.com)

**NOTICE:**

Precor is widely recognized for its innovative, award winning designs of exercise equipment. Precor aggressively seeks U.S. and foreign patents for both the mechanical construction and the visual aspects of its product design. Any party contemplating the use of Precor product designs is hereby forewarned that Precor considers the unauthorized appropriation of its proprietary rights to be a very serious matter. Precor will vigorously pursue all unauthorized appropriation of its proprietary rights.

Download from [Www.Somanuals.com](http://www.Somanuals.com). All Manuals Search And Download.

Experience Strength™ C-Line Owner's Manual  
CW34880-101, en  
1 November 2008

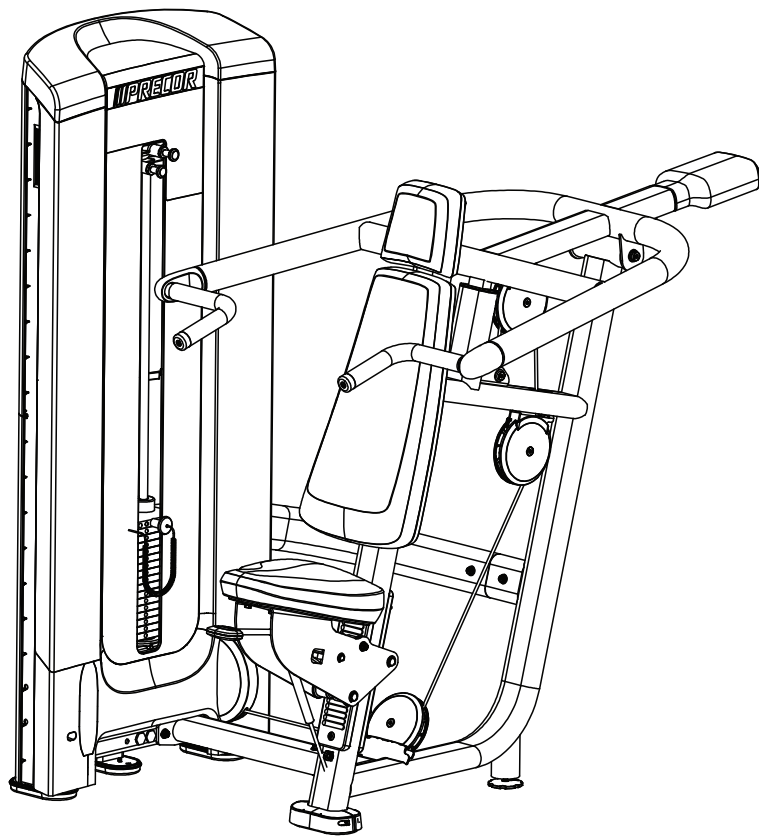

## Assembly and Delivery Guide

---

Experience Strength™ C-Line  
Shoulder Press



# Table of Contents

<b>Getting Started .....</b>	<b>2</b>
Open the Box .....	2
Required Tools .....	2
<b>Attach the Feet and Foot Covers .....</b>	<b>3</b>
<b>Attach the Bottle Holder/Accessory Tray .....</b>	<b>6</b>
<b>Assemble the Shroud .....</b>	<b>7</b>
<b>Disassemble the Equipment .....</b>	<b>12</b>

# Getting Started

**Note:** Assemble the weight stack shroud and bottle holder/accessory tray after the equipment is positioned in the facility.

Assembly takes about 15 minutes to complete. If this is the first time you have assembled this type of equipment, allow more time.

## Open the Box

Open the box and remove the packing materials.

Before you begin installing the weight stack shroud assembly, verify that you have received the following parts:

### For Weight Stack Shroud Assembly

- One front shroud assembly (CW34005)
- One pulley cover (CW34012)
- One lower left corner cover (CW34343)
- One lower right corner cover (CW34343)
- One pulley plug cover (CW34013)
- One lower middle cover (CW33945)
- One lower back cover (CW33944)
- One upper back cover (CW34375)
- One top cover (CW33947)
- One adjustable foot (CW39916-102)
- One foot cover with 75-degree upper opening (front, CW34061-103; back, CW34061-104)
- Two #8 x 1¼" Phillips-head self-tapping screws

- Ten ¼"- 20 buttonhead screws
- Two #8 x ⅝" Phillips-head self-tapping screws

### For Attaching Bottle Holder/Accessory Tray

- One bottle holder/accessory tray (CW34368)
- One U-shaped bottle holder bracket (CW34364)
- Two #8 - 32 machine screws
- Two custom bolts
- Two lock washers
- Two flat washers
- Two ⅜" - 16 low head bolts

## Required Tools

- One ⅜" hex key
- One ⅝" hex key
- One ¼" hex key
- One ⅞" socket wrench
- One ¾" open-end or box-end wrench
- One 1" open-end or box-end wrench
- One #2 Phillips screwdriver

**Caution: Do not use power tools to tighten screws attaching the weight stack shroud components. Using power tools may void the Precor warranty.**

# Attach the Feet and Foot Covers

## To Attach the Adjustable Foot:

1. Align the adjustable foot with the hole built into the cylindrical leg.
2. Screw the adjustable foot into the leg until the machine sits level on the floor.

**Caution:** To prevent damage to the adjustable foot, screw it all the way into the frame before moving equipment.

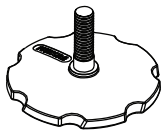
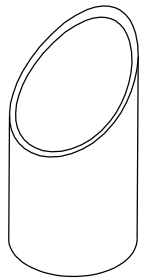

**Figure 1: Adjustable foot attachment**

The following graphic shows the location of the adjustable foot.

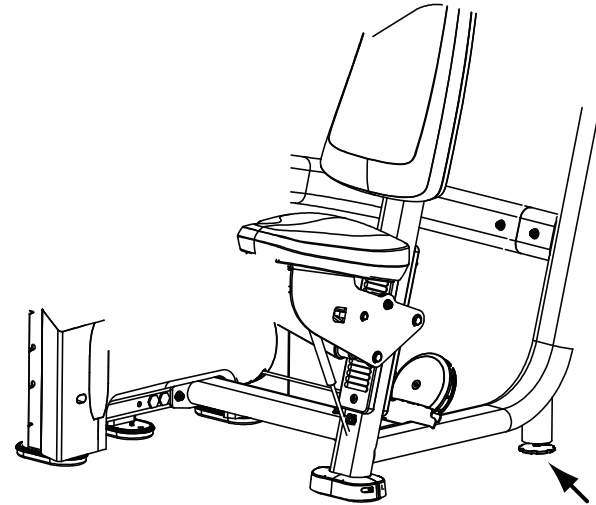
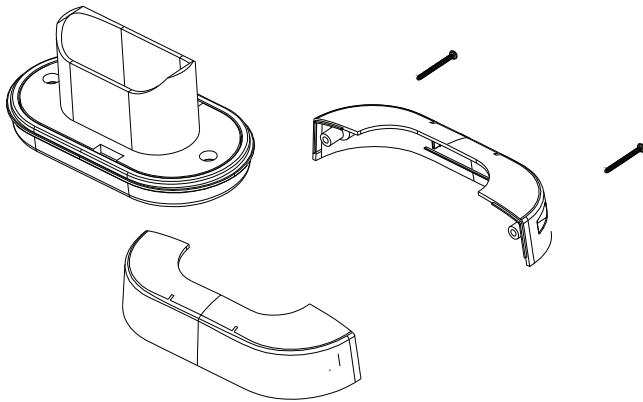

**Figure 2: Adjustable foot and foot cover attachment locations**

## To Attach the Foot Covers:

**Note:** When you install each foot cover, no gap should appear between its front and back halves. Also, the opening in the top of the assembled foot cover should align with the angle of the frame leg attached to the foot.

1. Position the foot covers on either side of the equipment foot.
2. Attach the foot covers around the equipment foot using:  
Two #8 x 1¼" Phillips head self-tapping screws



**Figure 3: Foot cover attachments**

Use this illustration to ensure that the foot covers are positioned and attached correctly.

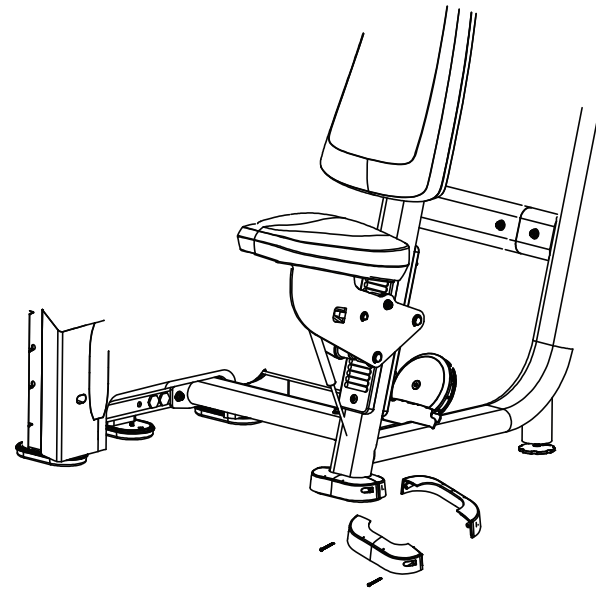

**Figure 4: Foot cover positioning**

## To Adjust the Stability Foot:

The stability foot is located centrally underneath the weight stack frame and should rest evenly on the floor. If the foot is not resting firmly on the floor, perform the following procedure.

**Note:** Adjustments to the stability foot must be completed before the shroud is attached.

1. Loosen the stability foot bolts using a 1" open-end or box wrench and a  $\frac{9}{16}$ " socket wrench.
2. Pull the stability foot downward so that it rests firmly on the floor.
3. Tighten the stability foot bolts using tools from step one.

**Important:** Once all foot adjustments are complete, gently rock the machine. If there is any movement, readjust the stability foot.

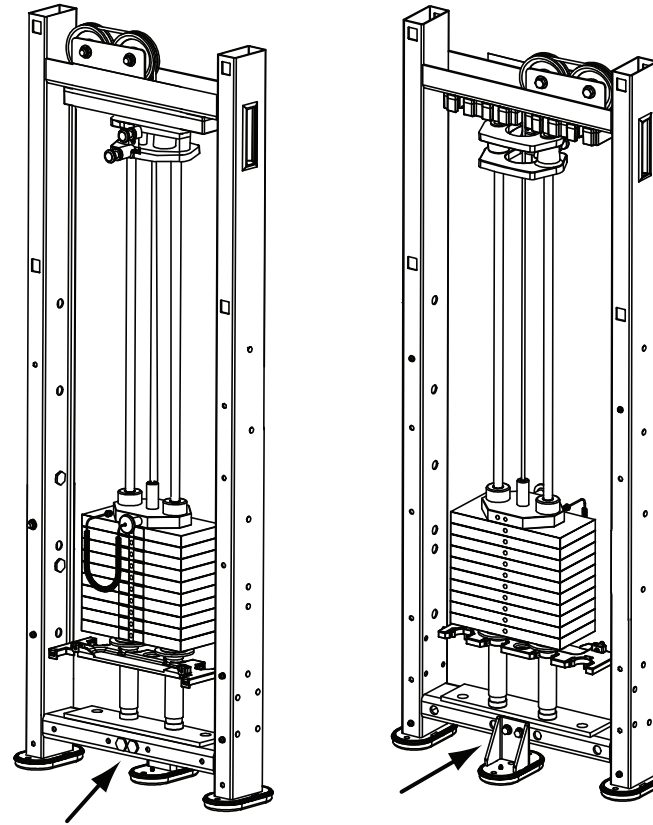

Figure 5: Location of stability foot and mountings



# Attach the Bottle Holder/Accessory Tray

## To Attach the Bottle Holder/Accessory Tray to the Weight Tower Frame:

1. Locate the bottle holder/accessory tray. Snap the two pieces together and set them aside.

**Note:** For this unit, the bottle holder/accessory tray attaches to the side of the front weight tower upright.

2. Place the bottle holder bracket upside down (curved side at the top) and attach it to the weight stack tower using:

Two custom bolts

Two lock washers

Two flat washers

Two  $\frac{3}{8}$ " - 16 low head bolts

One  $\frac{3}{16}$ " hex key

One 1" open-ended wrench

**Note:** The custom bolts pass through the frame from the inside hole and align with the smaller hole on the outside of the frame.

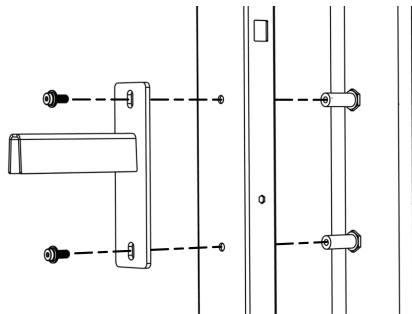

Figure 6: Bottle holder bracket attachment

3. Set the bottle holder/accessory tray on top of the bottle holder bracket and align it with the bracket screw holes. Attach it to the bracket using:

Two #8 - 32 machine screws

**Note:** Attach screws firmly, but do not overtighten.

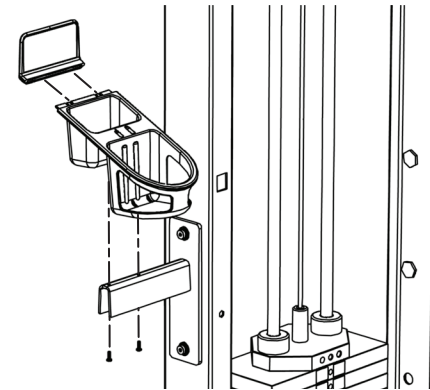

Figure 7: Bottle holder/accessory tray attachment

# Assemble the Shroud

## Before Beginning the Assembly

All cables should be correctly seated and tensioned. Make any adjustments before you install the shroud assembly.

**Caution:** Do not overtighten fasteners. Do not use power tools to tighten screws attaching the weight stack shroud components. Using power tools may void the Precor warranty. Screw fasteners into the plastic until the plastic makes full contact with the steel frame. If you overtighten the fasteners, you can damage the plastic shroud cover.

## To Install the Pulley Cover:

1. Position the pulley cover over the bottom pulley so that the cable passes through the cable slot.

**Note:** The universal corner pulley covers are designed to fit both left and right pulley locations.

2. Snap the plastic tabs on the pulley cover around the pulley mounting bracket.

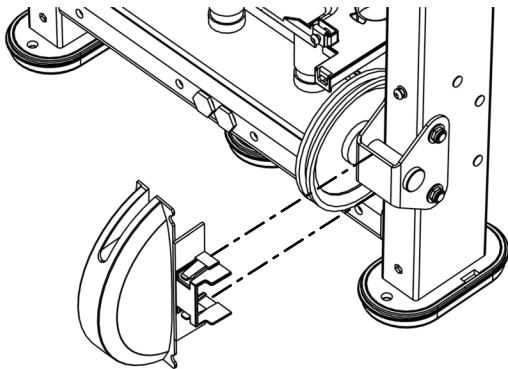

Figure 8: Alignment of pulley cover to pulley mounting bracket

## To Install the Front Shroud:

1. Remove the weight selection pin and set it on top of the weight stack before proceeding.
2. Lift the front shroud sufficiently to clear all parts of the exercise station. If necessary, arrange the front shroud so that its hooks are at the top and facing the weight stack frame.

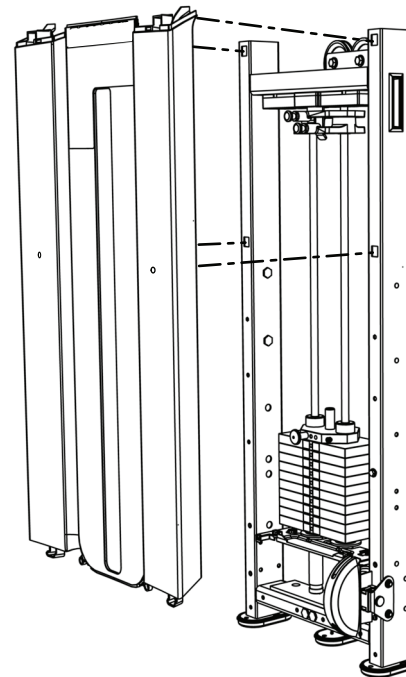

Figure 9: Front shroud attachment

- Slide the bottom edge of the front shroud into the space between the exercise station and the weight stack frame.
- When the plastic hooks on the front shroud line up with the large square holes at the top of the weight stack frame, place the hooks into the holes. A second set of hooks halfway up the shroud fits into holes in the weight tower frame. If necessary, lift the front shroud until the hooks drop into their holes in the weight tower frame and lower shroud until the hooks are supporting the shroud on the frame.

**Note:** When attaching screws, take care to avoid cross-threading.

- Attach the bottom edge of the front shroud using:

Four ¼" - 20 buttonhead screws

- Leave the screws slightly loose until all four of them are attached and the front shroud is positioned correctly, and then tighten them using the 5/32" hex key until snug.

**Note:** Two of the four screw locations are inside the sockets at the lower corners of the front shroud. The other two are between them along the bottom edge of the shroud.

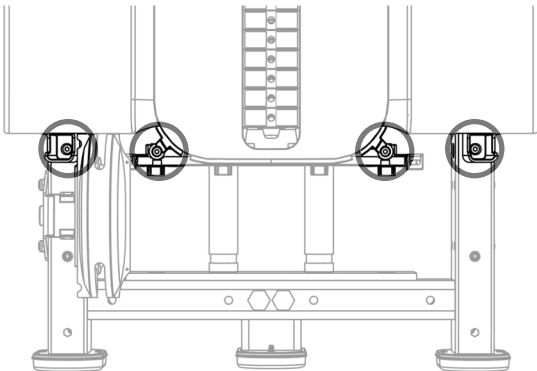

**Figure 10: Screw locations on the front shroud**

- Replace the weight selection pin in the weight stack.

## To Install the Covers Below the Front Shroud:

**Note:** Do not tighten all fasteners for the bottom covers until all shroud parts are in place.

- Locate the two bottom corner covers (one left, one right). Select the cover that corresponds to the pulley location. Tilt the cover down and slide the tab under the front shroud. Secure the lower corner cover using:

One ¼" - 20 buttonhead screw

**Note:** As you attempt to attach the corner cover, you might encounter resistance from the pulley cover. Tilting the corner cover down and applying pressure will ensure that it is properly positioned.

Tighten screw using a 5/32" hex key until snug.

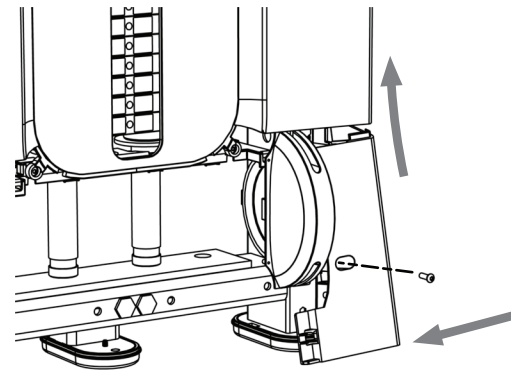

**Figure 11: Installation of corner cover**

- Fasten the cover plate to the second lower corner cover using:  
Two #8 self-tapping screws

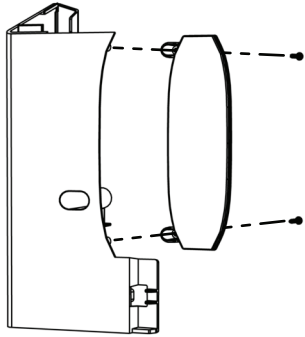
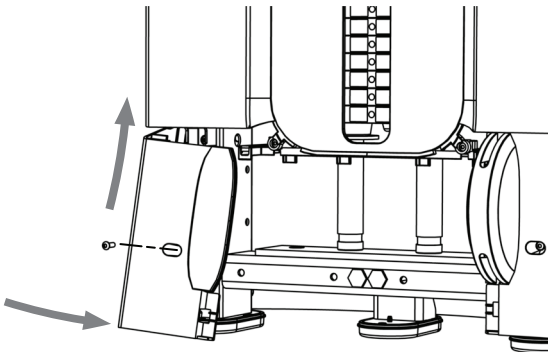

**Figure 12: Attachment of cover plate to the lower corner cover**

- Slide the retaining feature on the second lower corner cover under the front shroud on the remaining corner and attach the second lower corner cover using:

One 1/4" - 20 buttonhead screw

Tighten screw using a 5/32" hex key until snug.



**Figure 13: Tab slides under the front shroud**

- Attach the lower middle cover by squeezing and snapping its tabs into the slots in the frame.
- Firmly press the tabs located at the top of the lower middle cover under the bottom edge of the front shroud.

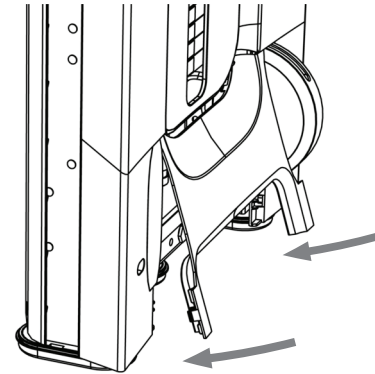

**Figure 14: Lower middle cover attachment**

- Tighten all bottom shroud fasteners until snug.

## To Install the Upper and Lower Back Shroud:

1. Position the lower back so that its tabbed end is at the top.

**Note:** Do not tighten any of the screws until all four screws are attached.

2. Line up the two screw holes near the upper corners of the lower back with the corresponding holes in the weight stack frame.
3. Attach the upper corners of the lower back to the weight stack frame using:  
Two ¼" - 20 buttonhead screws
4. Attach the lower corners of the lower back using:  
Two ¼" - 20 buttonhead screws
5. Tighten all four screws using a 5/32" hex key until snug.
6. Position the upper back so that its tabbed end is at the bottom and insert its tabs between the tabs at the upper edge of the lower back.

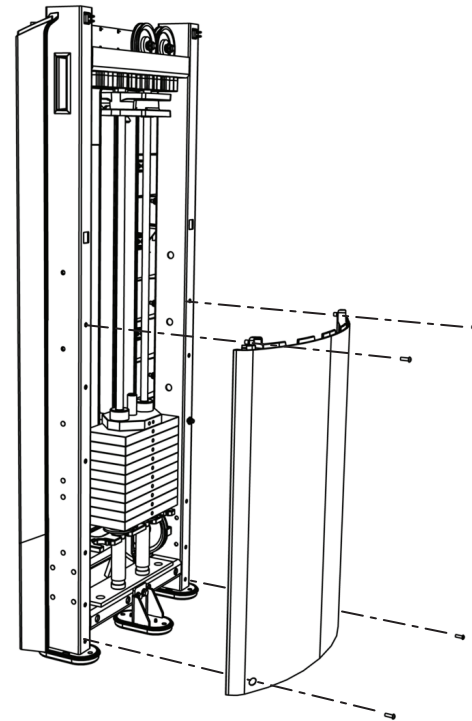

**Figure 15: Lower back shroud attachment**

7. Insert the tabs in the top corners of the upper back into the square holes at the top of the weight stack frame and push the corners in until the tabs lock into place.

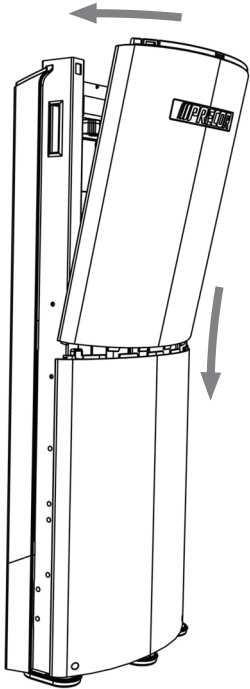

**Figure 16: Upper back shroud attachment**

### **To Install the Top Cover:**

1. Insert the tabs on the top cover into the matching slots in the shroud assembly.
2. Push down on the top cover until its tabs lock into place.

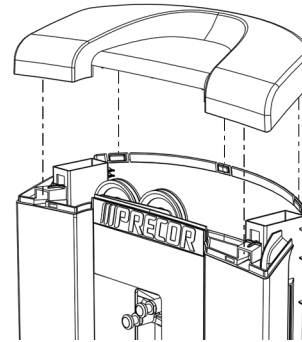

**Figure 17: Shroud top cover attachment**

### **To Remove the Nameplate Protective Film:**

1. Locate the Precor nameplates on the front and back sides of the assembled shroud.
2. Peel the protective film off each Precor nameplate.

# Disassemble the Equipment

This unit arrives fully assembled except for the shrouds and the bottle holder/accessory tray. In some cases, you may need to disassemble the unit before you move it.

**WARNING:** You will need assistance to disassemble this unit. The weight tower is unstable when disconnected from the exercise station. Make sure the weight tower is supported safely during disassembly. Do not attempt disassembly by yourself.

## To Detach the Cable:

1. Loosen the locking jam nut and unscrew the bolt in the center of the top weight cap using a  $\frac{3}{4}$ " open-end wrench.
2. Route the cable through the top of the weight tower and down to the lower 6" pulley.
3. Remove the shoulder bolt from the 6" pulley using a  $\frac{1}{4}$ " hex key.
4. Unfasten the 6" pulley and unthread the cable.

**Note:** Remove the pulley cable from the weight stack and keep it attached to the exercise station.

## To Separate the Weight Tower from the Exercise Station:

**Note:** The exercise station is attached to the weight tower at a side location and a bottom location.

1. Locate the side area where the exercise station is bolted to the weight tower.
2. Remove the upper and lower bolts using a  $\frac{3}{16}$ " hex key and a 1" open-end wrench.

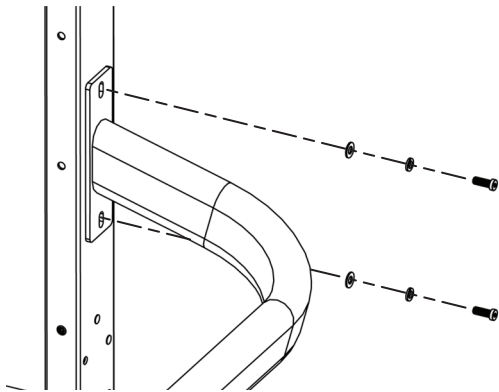

**Figure 18: Remove side bolts from the weight tower**

3. Locate the bottom area where the exercise station is bolted to the weight tower.
4. Remove the bolts on the bottom area using a  $\frac{3}{16}$ " hex key and a 1" open-end wrench.

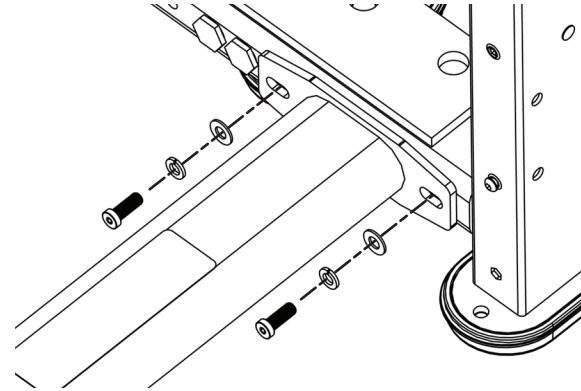

**Figure 19: Remove bottom bolts from the weight tower**



## To Reroute the Cable During Reassembly:

1. Check the position of the cable on the movement arm cam and all pulleys to ensure that they are properly seated.

**Note:** To prevent cable damage in the following step, the cable must be inside the hook and must rest in the central grooves of the pulleys.

2. Reroute the cable around the lower 6" pulley and inside the hook at the rear of the pulley mounting bracket.

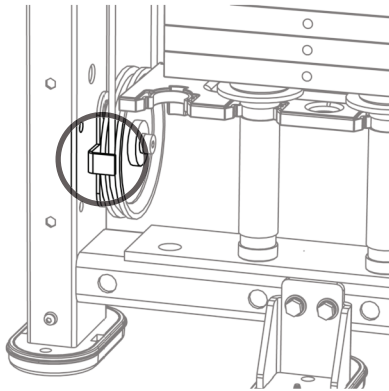
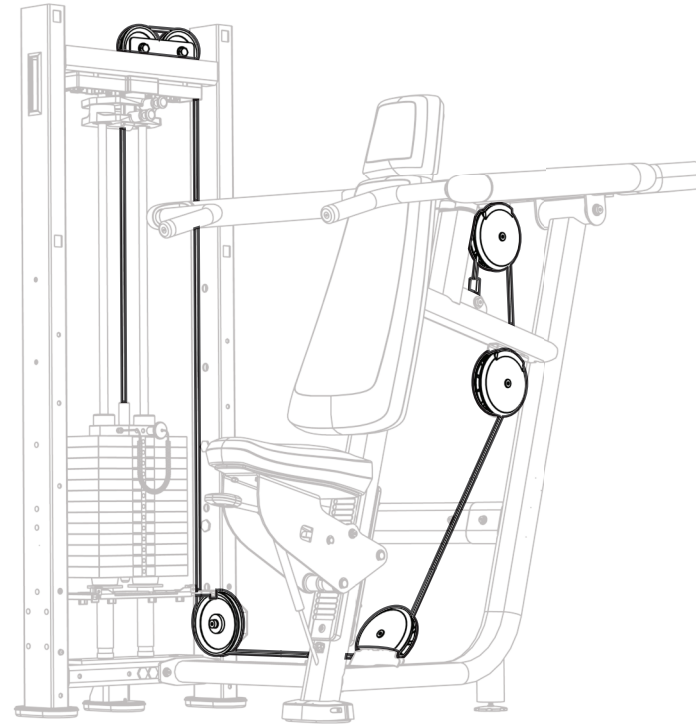

**Figure 20: Thread cable inside the hook**

3. Attach the 6" pulley and shoulder bolt to the weight tower using a 1/4" hex key. Tighten securely.
4. Route the cable up through the hole in the top corner of the weight tower, over the pulleys, and down through the hole directly over the weight plates.

The following illustration shows how the cable is rerouted to the weight stack frame.

**Note:** Visually check the pulleys to ensure that they are aligned to avoid cable friction and positioned as shown in the illustration.

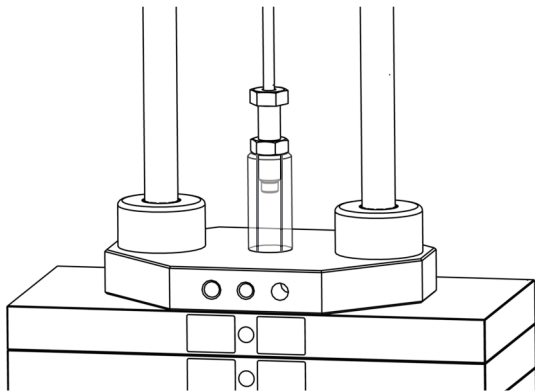

**Figure 21: Cable rerouting**

**WARNING: At the end of the following step, a minimum of 10 threads on the cable bolt must be inserted within the weight stack's selector stem. Verify that the cable is fully seated in all pulleys before installing the cable bolt into the stem.**

5. Screw the cable bolt into the weight stack's selector stem until the cable meets the following requirements:
  - No excess slack remains.
  - The cable is just loose enough to permit insertion of the selector pin into any of the weight plates.
  - At least 10 threads on the cable bolt extend into the selector stem.
6. Tighten the locking jam nut firmly against the selector stem using a  $\frac{3}{4}$ " open-end wrench. Hold the  $\frac{1}{2}$ "-20 bolt to prevent it from turning.

**WARNING: To prevent injury, make sure the locking jam nut is firmly tightened.**



**Figure 22: Screwing the cable bolt into the weight stack's selector stem**

7. Check the adjustment by inserting the weight pin into every weight plate hole. The weight pin should slide easily in and out of each weight plate.
8. Verify that the cable is routed properly by selecting one weight plate and operating the unit to test for smooth movement.

**Caution: If the cable does not slide smoothly throughout its route, stop equipment use immediately and recheck the cable assembly.**

*Notes*





Precor Incorporated  
20031 142nd Ave NE  
P.O. Box 7202  
Woodinville, WA USA 98072-4002  
1-800-347-4404

Precor is a registered trademark of Precor Incorporated.  
Copyright 2009 Precor Incorporated.  
Specifications subject to change without notice.  
[www.precor.com](http://www.precor.com)

**NOTICE:**

Precor is widely recognized for its innovative, award winning designs of exercise equipment. Precor aggressively seeks U.S. and foreign patents for both the mechanical construction and the visual aspects of its product design. Any party contemplating the use of Precor product designs is hereby forewarned that Precor considers the unauthorized appropriation of its proprietary rights to be a very serious matter. Precor will vigorously pursue all unauthorized appropriation of its proprietary rights.

Assembly and Delivery Guide CW34834-141 rev D, en  
1 February 2009

## Free Manuals Download Website

<http://myh66.com>

<http://usermanuals.us>

<http://www.somanuals.com>

<http://www.4manuals.cc>

<http://www.manual-lib.com>

<http://www.404manual.com>

<http://www.luxmanual.com>

<http://aubethermostatmanual.com>

Golf course search by state

<http://golfingnear.com>

Email search by domain

<http://emailbydomain.com>

Auto manuals search

<http://auto.somanuals.com>

TV manuals search

<http://tv.somanuals.com>