



P T - 5 8 0 0 A m p l i f i e r



P T - 6 8 0 0 A m p l i f i e r

Owner's Manual

www.pyleaudio.com

Limited Warranty

All PYLE PRO products are carefully constructed and tested before shipment. Units purchased in the USA are warranted to be free of defects in material and workmanship for two (2) years from the date of purchase. This warranty is limited to the original retail purchaser of the amplifier.

Should the unit fail due to factory defects in material or workmanship, your unit will be repaired or replaced at the sole discretion of PYLE.

To obtain warranty service, you must first call our Consumer Return Hotline at (718) 236-6948 to obtain a Return Authorization Number. This R.A. # must appear on the outside of your package and on all paperwork relating to your return.

When returning the unit to us for warranty service, it must be carefully packed and shipped, prepaid, to:

R.A.#: _____
PYLE PRO Service Center
 1600 63rd Street
 Brooklyn, NY 11204

You must also include the following items with your return:

- A copy of your sales receipt or other proof of purchase
- A brief letter, indicating the problem you are experiencing with the product
 - Include in your letter your return address, daytime phone number and R.A. number
 - Also include a check or money order for \$20.00 for return shipping, handling and insurance, or provide your Visa/MC number with expiration date.

Our obligation under this warranty is limited to the repair or replacement of the defective unit when it is returned to us prepaid. This warranty will be considered void if the unit was tampered with, improperly serviced or subject to misuse, neglect or accidental damage.

▶ Please complete warranty card, detach and return ▶

Thank you for purchasing this PYLE product. To activate your warranty, please mail this card within 10 days.

Name _____
 Address _____
 City, State ZIP _____

PYLE PRO AMPLIFIERS

warranty registration card

Model No. _____ Serial # (if available) _____

Date of Purchase _____

Purchased at: Music Products Store Sound Contractor/Installer Mail Order
 Catalog Merchandiser Other _____

Your New Pyle Pro PT series P.A. Amplifier gives you the power and versatility you need in a professional sound system.

The amplifier's wide frequency response makes it suitable for amplifying music or vocal program material. It can be used for live bands, office paging systems, public announcements, or a variety of other installations.

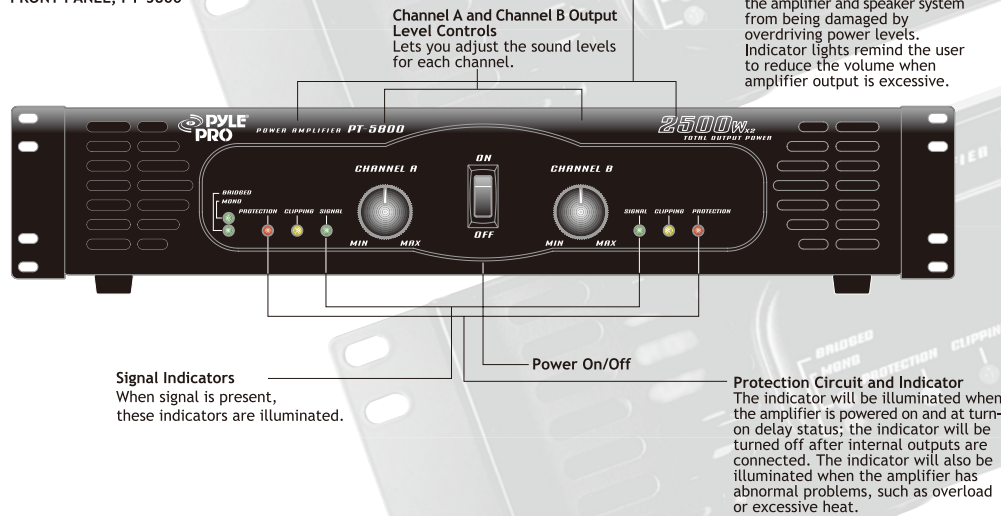

TABLE OF CONTENTS

- 1 Features and Controls, PT-5800 and PT-6800
- 2 Installation Guidelines
- 2 Input Connections
- 2 Connecting a CD, DVD or tape player or tuner
- 2 Connecting an equalizer or signal processor
- 2 Low Cut Filter
- 2 Stereo or Mono Inputs
- 2 Speaker connections
- 3 Bridged Mode Operation
- 3 Speakon Outputs
- 3 Connecting to standard AC power
- 3 Mounting the amplifier
- 3 Turning the amplifier on
- 3 Using the channelA and channelB output level controls
- 3 About the internal clip circuitry
- 4 Caring for your Pyle Pro Amplifier
- 4 Resetting the circuit breaker
- 4 Specifications
- 5 Limited warranty

Please read this manual thoroughly before you attempt to set up and use the amplifier. It contains a range of installation suggestions as well as instructions to ensure safe usage. Installed properly, you can expect years of trouble-free service from this product.

**FEATURES AND CONTROLS
FRONT PANEL, PT-5800**



**FEATURES AND CONTROLS
FRONT PANEL, PT-6800**

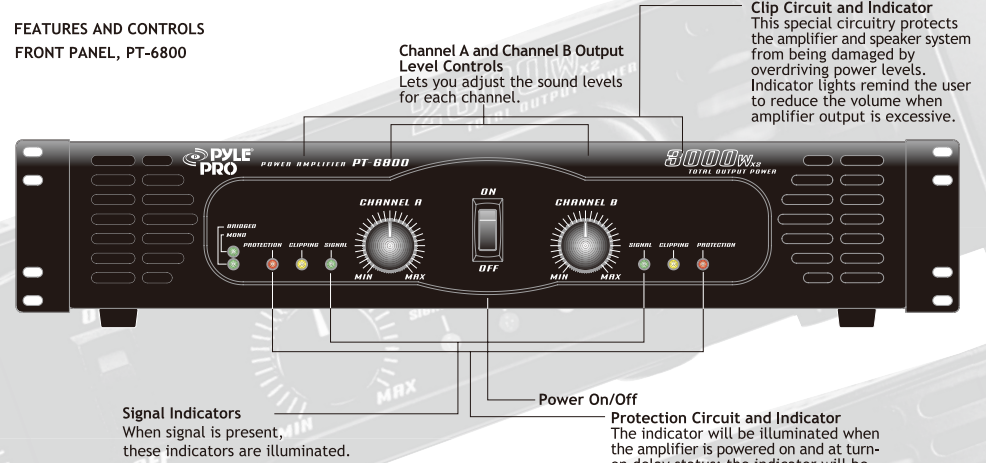

REAR PANEL, PT-5800/ PT-6800

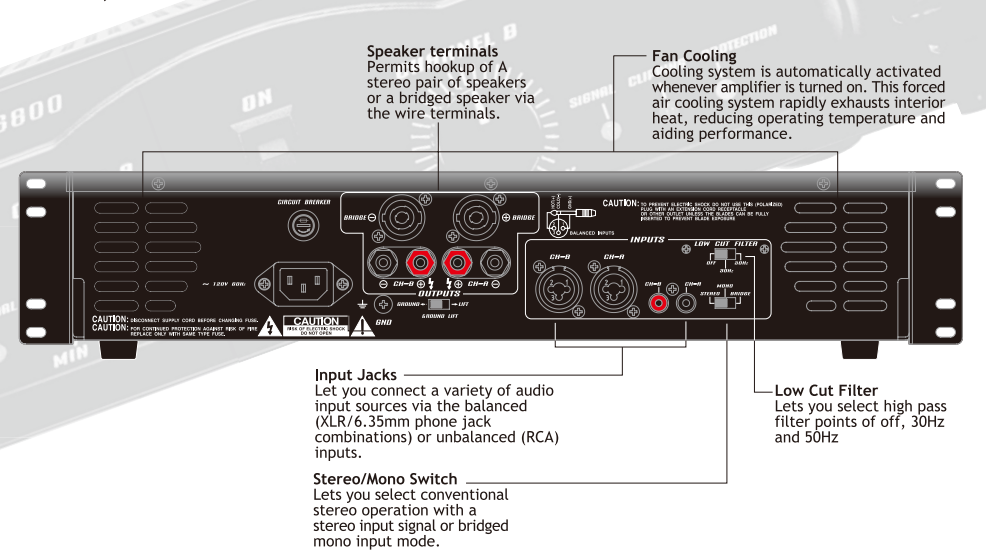

INSTALLATION GUIDELINES

Connecting the GND (GROUND) screw terminal Connecting a mixer or preamplifier may cause excessive noise or hum in the amplifier output. To prevent this, connect one end of a low-capacitance shield wire to the amplifier's ground screw (on the rear panel). Then connect the other end of this wire to the ground terminal on the mixer or preamplifier enclosure.

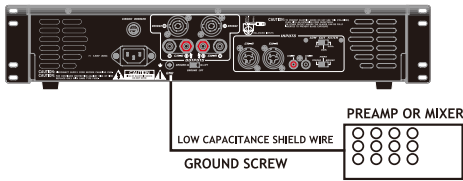

Input connections

These amplifiers accept a board range of input sources, including Compact Disc (CD,DVD) players; Cassette, Reel-to-Reel or other tape players; Radio Tuners; Equalizers; Signal Processors.

Connecting a CD, DVD, tape player or tuner

In a normal installation, one would use the RCA JACKS for connecting a CD player, DVD player, tape player or tuner.

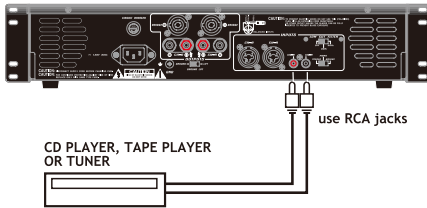

Connecting an equalizer or external signal processor

Connect the processor's OUT to the amplifier's IN connector.

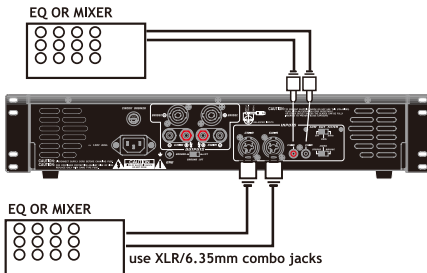

Stereo or Mono Inputs

Your Pyle Pro amplifier can be operated in Stereo, Mono or Bridged mode, depending on the input source. If the input signal is mono, slide the Stereo/Mono/Bridged selector switch to MONO and the signal will be routed through both channels. If you wish to run the amplifier in bridged output mode, slide the switch to Bridged.

Low Cut Filter

The LF (high-pass) filter removes frequencies below 30 and 50 Hz respectively. The reproduction of the signal's bass portion is thus optimized, since ultra-low, distracting frequencies are eliminated, and more power is available for the reproduction of the wanted segment of the signal.

Speaker connections

You can connect 4 Ohm, 8 Ohm or 16 Ohm speakers to Channel A and/or Channel B of the amplifier. If you connect two pairs of speakers, be sure to follow these guidelines:

- Speakers which are connected to the same channel are part of a pair, and must be of the same impedance.
- Speakers connected to different channels are NOT part of a pair, and can be of different impedances.

1. Prepare the speaker wire by removing about 1 inch of insulation from the end of the speaker wire you intend to connect to the amplifier. Then twist the exposed wire to secure all the wire strands.

NOTE: Use 16-gauge speaker wire for lengths up to 25 feet; 14-gauge wire for lengths over 25 feet. It is recommended that you use the shortest length of wire possible.

2. Connect the speaker wires to the speaker's positive and negative terminals.

NOTE: Most speaker terminals are either color-coded or have a mark that indicates the terminal's polarity. Usually positive terminals are red or have a plus symbol (+), and negative terminals are black or have a minus symbol (-).

3. Connect the speaker wires to the amplifier's left and right speaker terminals according to the terminal color polarity.

STEREO OPERATION

SWITCH IN "STEREO" POSITION

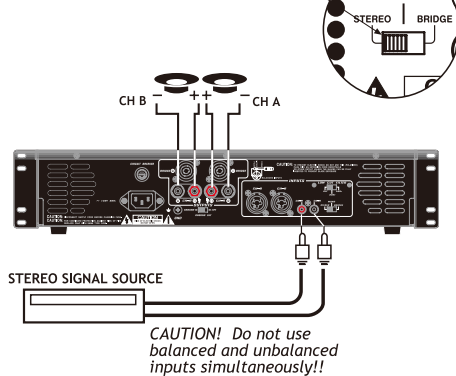

MONO OPERATION

SWITCH IN "MONO" POSITION

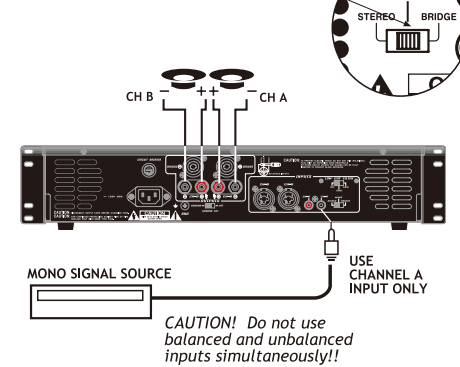

Bridged Mode Operation

This amplifier can operate in a mono bridged output mode, if your speakers can handle the following power output levels:

PT-5800: 2500x2 watts PT-6800: 3000x2 watts

As shown in the diagram below, connect the speaker's positive (+) to the amplifier's red speakers left (A/B) terminals and negative (-) to red speakers right (A/B) terminals.

The speaker right (+) on the amplifier is used as a negative (-) terminal for a bridged connection.

NOTE: The extra amplifier output of 6.35mm phone jacks can not be used for the bridged connection. It can only be used in normal (non-bridged) operation as a stereo speaker output.

MONO BRIDGED OPERATION

SWITCH IN "BRIDGED" POSITION

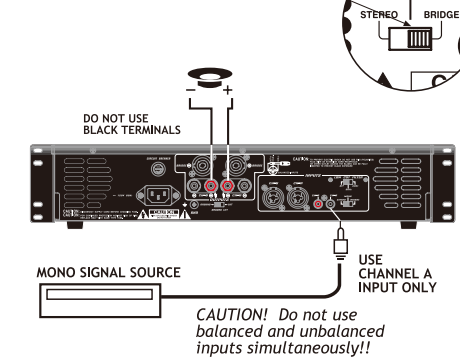

Speakon Outputs

The speakon connectors were especially developed for driving high-power speakers. They snap in securely, prevent electric shock and assure correct polarity. The Upper Speakon connector drives either one or both channels, and is therefore well-suited for mono-bridged operation (1+ / 2+). The lower connector carries the signals from channel B only.

CHA Pinout Output A	
1+	1-
Pos	Neg
Output B	
2+	2-
Pos	Neg
Bridge	
1+	2+
Pos	Neg

CHB Pinout Output B	
1+	1-
Pos	Neg

Connecting to standard AC power

After making all other connections, set the POWER switch to OFF position. Then connect the power cord to a standard AC outlet.

Mounting the amplifier

This amplifier is designed to accept standard rack mounting installations. Two slots on each end of the front panel make it suitable for such an installation.

Tightly secure four mounting screws (not supplied) through these four slots and into your standard electronics equipment rack.

Turning the amplifier on

1. Turn on the audio input source equipment which is connected to the amplifier INPUT jacks.
2. Set the amplifier's Channel A and Channel B output level gain controls to the minimum level settings.
3. Push in the power switch to turn the amplifier on.

Using the Channel A and Channel B Output Level controls
Rotate output level gain clockwise to increase, or counterclockwise to decrease the output power. To get the best performance with the least sound distortion, always adjust the output level gain so the meter's pointer does not continuously exceed the extreme right of the meter's scale.

CAUTION: It is possible to overdrive the amplifier by setting output level gain too high, which may cause damage or failure.

About the internal clip circuitry

Special clip circuitry incorporated into your Pyle Pro amplifier's design protects the amplifier and speaker system from being damaged from overdriving power.

Under normal conditions, the amplifier's clip indicator will flicker as the output power momentarily exceeds the level as set by the output level gain selector.

However, under excessive output conditions, the clip indicator lights remain on continuously, alerting you that the special clip circuitry has become active. When this occurs, you should simply reduce the output power level by rotating the Master Volume control counterclockwise.

PYLE PRO

Caring for your Pyle Pro Amplifier

Your Pyle Pro Amplifier is an example of superior design and craftsmanship. The following suggestions will help you care for your amplifier so you can enjoy years of use:

- Keep the amplifier dry. If it gets wet, wipe immediately.
- Use the amplifier only in well-ventilated installations.
- Handle the amplifier gently and carefully - do not drop!
- Keep the amplifier away from dust and dirt.
- Wipe occasionally with a damp cloth to keep it looking new. Do not use harsh chemicals, solvents or detergents!

Resetting the circuit breaker

This amplifier employs a circuit breaker for protection from power surges and short circuits. If the amplifier suddenly turns off or will not turn on, check the circuit breaker. If it is tripped, check and correct for a short or overload condition. Wait for the amplifier to cool, then press the circuit breaker RESET button on the back of the amplifier.

Amplifier Specifications	PT-5800	PT-6800
Input Impedance, balanced (unbalanced)	20 k-Ohms (10 k-Ohms)	20 k-Ohms (10 k-Ohms)
Continuous Output Power		
Stereo Mode		
20 Hz to 20 kHz, 8 Ohms	300W x 2	400W x 2
1 kHz, 4 Ohms	450W x 2	600W x 2
Maximum Power, 8 Ohms	350W x 2	450W x 2
Maximum Power, 4 Ohms	500W x 2	650W x 2
Peak Power, 8 Ohms	2500W x 2	3000W x 2
Bridged Mode		
20 Hz to 20 kHz, 8 Ohms	750W x 1	1000W x 1
1 kHz, 8 Ohms	900W x 1	1200W x 1
Peak Power	5000W x 1	6000W x 1
THD at rated output power	0.1%	0.1%
Frequency Response +/- 3 dB	10 Hz to 50 kHz	10 Hz to 50 kHz
Input Sensitivity for rated output power	1.0V	1.0V
Signal-to-Noise Ratio A-Weighted	100 dB	100 dB
Speaker Impedance		
Stereo	4-16 Ohms	4-16 Ohms
Bridged	8-16 Ohms	8-16 Ohms
Power Requirement	120 VAC, 60 Hz	120 VAC, 60 Hz
Dimensions H x W x D, inches (mm)	3.46 x 18.98 x 14.65 (88 x 482 x 372)	3.46 x 18.98 x 14.65 (88 x 482 x 372)
Weight, lbs (kg)	27.28 (12.4)	29.48 (13.4)



Place
Stamp
Here



Free Manuals Download Website

<http://myh66.com>

<http://usermanuals.us>

<http://www.somanuals.com>

<http://www.4manuals.cc>

<http://www.manual-lib.com>

<http://www.404manual.com>

<http://www.luxmanual.com>

<http://aubethermostatmanual.com>

Golf course search by state

<http://golfingnear.com>

Email search by domain

<http://emailbydomain.com>

Auto manuals search

<http://auto.somanuals.com>

TV manuals search

<http://tv.somanuals.com>