



P D S P 8 5 0 D i g i t a l S a m p l e r P r o c e s s o r

▼ Please complete warranty card, detach and return ▼

Thank you for purchasing this PYLE product. To activate your warranty, please mail this card within 10 days.

warranty registration card

PYLE PRO
PYLE PRO ELECTRONICS

Name _____

Address _____

City, State ZIP _____

Model No. _____ Serial # (if available) _____

Date of Purchase _____

Purchased at:
 Music Products Store Sound Contractor/Installer Mail Order
 Catalog Merchandiser Other _____



Owner's Manual

www.pyleaudio.com

Your PYLE PRO series Digital Sampler Processor is created to provide the stereo audiophile with a sophisticated control center for sampling the sound from multiple input sources and directing the signal to a sound processor or power amplifier for playback.

Please read this manual thoroughly before you attempt to set up and use this PDSP850. It contains a range of installation suggestions as well as instructions to ensure safe usage. Installed properly, you can expect years of trouble-free service from this product.



FEATURES AND CONTROLS

FRONT PANEL

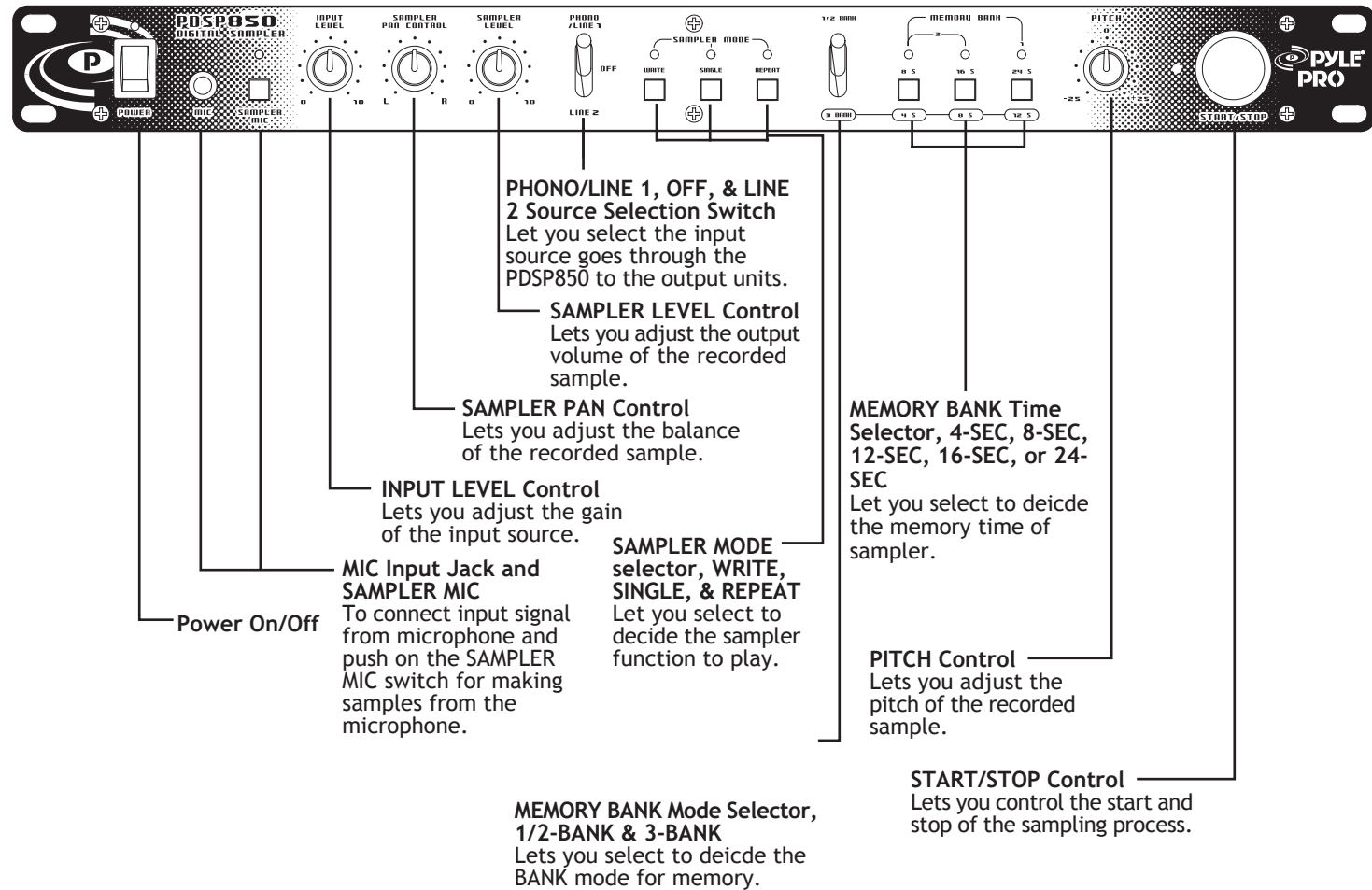

REAR PANEL

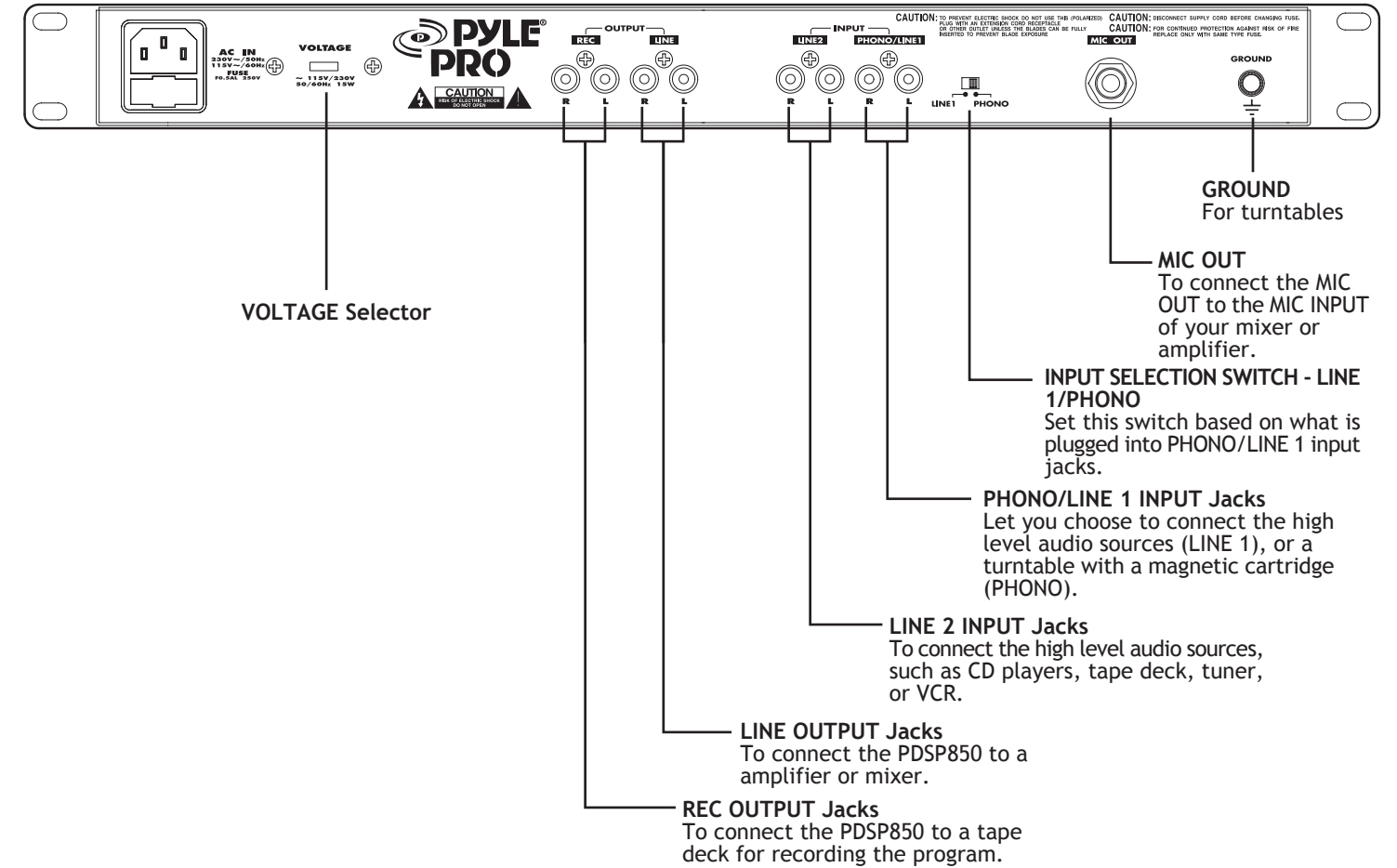

INSTALLATION GUIDELINES

1. Input Connections

The PDSP850 accepts a board range of input sources, including:

Compact Disc (CD) player
Camecorder or VCR
Cassette, Reel to Reel or other tape recorder or player
Radio Tuner
Turntable

These can be connected via RCA type jacks to the input jacks on the rear panel of PDSP850.

Connecting a High Level Output Audio Sources

Connect up to 2 such sources (tuner, cassette deck, cd player, camcorder or VCR) to the input jacks for LINE 1 (if not being used as PHONO input) and LINE 2. Please note that PHONO and LINE 1 use the same jacks, The jacks should be set to LINE 1 if the jacks are used for the High Level input sources described here.

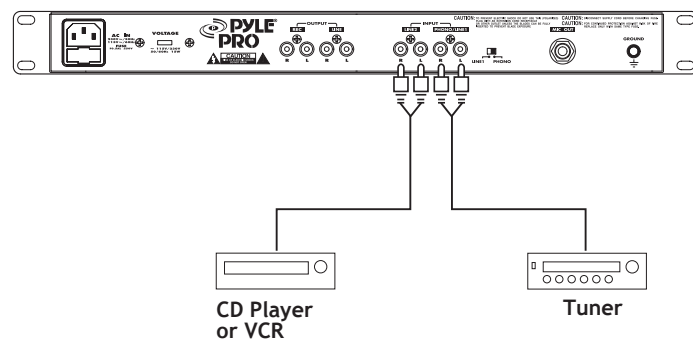

Connecting a Phono Turntable

Connect a turntable to the PHONO/LINE 1 input jacks. Please set the LINE 1/PHONO selection switch to PHONO.

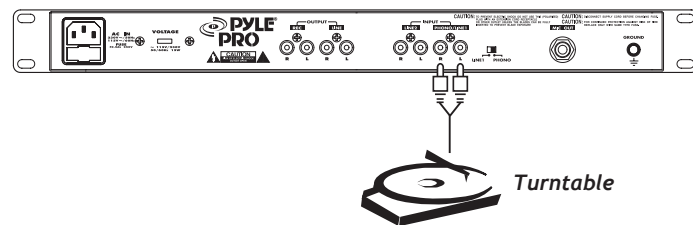

2. Output Connections

Connecting The MIC OUTPUT

Connect the MIC INPUT of your mixer or amplifier to MIC OUT jacks.

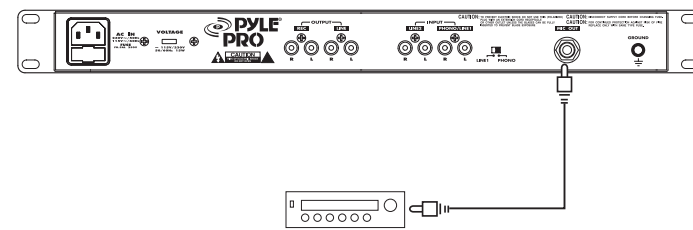

Connecting The LINE OUTPUT

The PDSP850 has been designed to provide output to a power amplifier or sound processor (mixer).

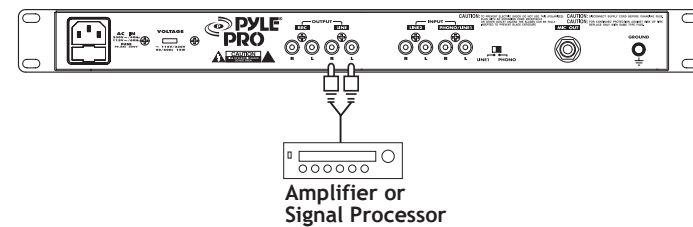

Connecting The REC OUTPUT

The PDSP850 has been designed to serve as an audio source for tape recording.

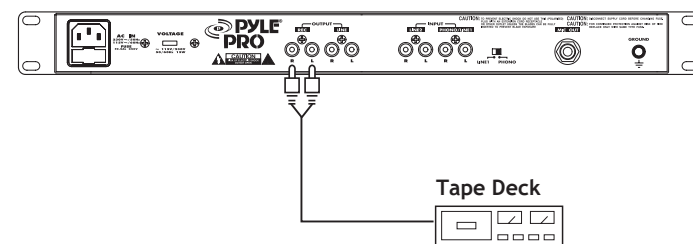

3. Grounding the preamplifier

Grounding your turntable to an earth ground is a good idea in order to reduce or eliminate hum or static that the phono system may introduce to the audio signal path. Securely fasten a wire from the ground screw on the rear panel to the ground lead from your turntable.

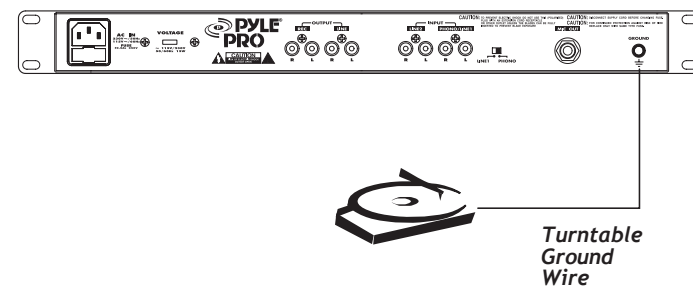

4. Standard AC Power Connection

After making all other connections, set the POWER switch to OFF position. Then connect the power cord to a standard AC outlet.

OPERATIONS

1. Selecting the Input Source, PHONO/LINE 1, OFF, & LINE 2
Select the input signal goes through the PDSP850 by setting the PHONO/LINE 1, OFF, & LINE 2 selector on the front panel to the position selected.

PHONO/LINE 1: The source connected to PHONO/LINE 1 input jacks on the back panel will be selected.

LINE 2: The source connected to LINE 2 input jacks on the back panel will be selected.

OFF: No signals from PHONO/LINE 1 & LINE 2 will be through the unit to the mixer.

It is good to use when you are playing back the recorded sample, to eliminate the signal inputting from the selected sources.

2. Connecting MIC

Input connection using 1/4" jack

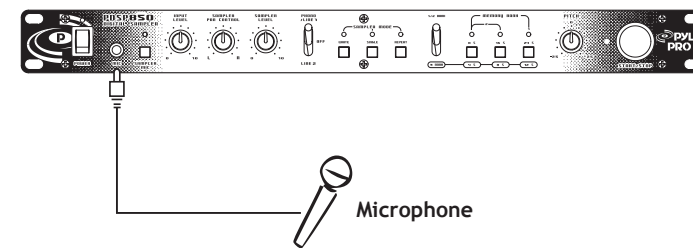

3. Using the SAMPLER MIC switch

To make the sample from the microphone, push the SAMPLER MIC button (the LED indicator will be illuminated). The microphone signal going to the sampler. The selected source will still play through the unit but it can not be sampled. The microphone output is controlled by the microphone section of your mixer.

4. Using the INPUT LEVEL control

Adjusting the gain of input source to fine tune the level, since input levels usually vary. Rotate the INPUT LEVEL clockwise to increase levels.

USING THE DIGITAL SAMPLING

1. The BANK MODE and MEMORY TIME BANK
The PDSP850 equipped with two options of BANK MODE, 1/2-BANK & 3-BANK, and each mode has 3-MEMORY TIME BANK of choice. In 1/2-BANK mode, you can choose either 1 BANK or 2 BANKS for recording, and in 3-BANK mode you can store the samples to all of 3 BANKS individually.

A. 1/2-BANK MODE

The recording time in this mode are:

1 BANK for 24 seconds (1-BANK MODE USE ONLY, IF THIS BANK IS STORED)

1 BANK for 8 seconds (LINKING WITH THE 2ND BANK OF 16 SECONDS FOR 2-BANK MODE USE)

1 BANK for 16 seconds (LINKING WITH THE 2ND BANK OF 8 SECONDS FOR 2-BANK MODE USE)

The 24 seconds bank is the longest recording time in PDSP850, you can not use the other banks to store the different samples in this mode, if this bank is stored.

The 8 and 16 banks are separate and can be linked, you can store a different sample in these two banks, but they must be recorded individually and they must be played one at a time.

B. 3-BANK MODE

The recording time in this mode are:

1 BANK for 4 seconds

1 BANK for 8 seconds

1 BANK for 12 seconds

These banks are separate and can be linked, you can store a different sample in these three banks, but they must be recorded individually and they must be played one at a time.

2. The SAMPLER MODE (WRITE/SINGLE/REPEAT) and START/STOP (RECORDING)

A. Select the source you want to sample by placing the input source selector (PHONO/LINE 1 & LINE 2) or the SAMPLER MIC button (see "Using the SAMPLER MIC switch" in OPERATION).

NOTE: The SAMPLER MIC must be in OFF mode, if making sample from the PHONO/LINE or LINE 2 source.

B. Select the BANK MODE and MEMORY BANK you want to record by placing the bank mode selector (1/2 BANK & 3 BANK) and pressing the proper MEMORY BANK (4, 8, 12, 16, or 24) button (the LED indicator will be illuminated).

C. TO RECORD - WRITE

Set the SAMPLER MODE switch to WRITE position (the LED will be illuminated) and press the START/STOP button (the LED will be RED illuminated) to begin the recording. Pressing the START/STOP button again, to stop the recording (the LED will be turned off). If you do not press stop, it will automatically stop after the selected MEMORY BANK TIME (4, 8, 12, 16, or 24 seconds) is up.

D. TO PLAYBACK - SINGLE

Set the SAMPLER MODE switch to SINGLE position (the LED will be illuminated) and press the START/STOP button (the LED will be GREEN illuminated) to playback the sampler one time. Every time you press the START/STOP button, the unit will replay the recorded sample from the beginning and play it through the end of recorded sound. Rapid, consecutive pressing of the START/STOP button will create an interesting stuttering effect.

E. TO PLAYBACK - REPEAT

Set the SAMPLER MODE switch to REPEAT position (the LED will be illuminated) and press the START/STOP button (the LED will be GREEN illuminated) to playback the sampler all the way through, and then repeat it until you press the START/STOP button to stop.



3. The SAMPLER LEVEL control

To adjust the level of the sample playback as it enters the mix, rotate the SAMPLER LEVEL to increase or decrease the level.

4. The SAMPLER PAN control

To adjust the balance of the sample playback as it enters the mix, set the control in the center position to playback the sample evenly through the left and right channel. Turning the SAMPLER PAN control to left or right will move the playback sample similar to a balance control.

5. The PITCH control

To adjust the speed of the playback signal.

Set the control to the center position and record the sample, to get a perfect sample. During the playback, rotate the PITCH control to reduce or increase the pitch of the sample, set to the center for a normal pitch.

PDSP850 Specifications	
Input Sensitivity/Impedance	
<i>Mic</i>	1.5mV/600 Ohms
<i>Line</i>	150mV/27k Ohms
<i>Phono</i>	3.0mV/47k Ohms
Output Level	
<i>Mic</i>	1.5mV/600 Ohms
<i>Line</i>	1.0V/1k Ohms
<i>Rec</i>	100mV/1k Ohms
Frequency Response	20Hz to 20k Hz (+/-3dB)
S/N Ratio	
<i>Mic</i>	>60dB
<i>Line</i>	>80dB
<i>Phono</i>	>70dB
Distortion	
<i>Mic</i>	<0.2%
<i>Line</i>	<0.02%
<i>Phono</i>	<0.08%
Sampling Length(ADPCM)	4sec X 1 16sec X 1 8sec X 2 24sec X 1 12sec X 1
Pitch Changer	+/- 1/2 Octave
Power Source	115VAc, 60Hz/230VAc, 50 Hz
Dimensions(HxWxD) (mm)	1 3/4" x 19" x 6" (44 x 482 x 153)
Weight, LBS(kg)	4.18(1.9)

Limited Warranty

All PYLE PRO products are carefully constructed and tested before shipment. Units purchased in the USA are warranted to be free of defects in material and workmanship for two (2) years from the date of purchase. This warranty is limited to the original retail purchaser of the amplifier.

Should the unit fail due to factory defects in material or workmanship, your unit will be repaired or replaced at the sole discretion of PYLE.

To obtain warranty service, you must first call our Consumer Return Hotline at (718) 236-6948 to obtain a Return Authorization Number. This R.A. # must appear on the outside of your package and on all paperwork relating to your return.

When returning the unit to us for warranty service, it must be carefully packed and shipped, prepaid, to:

R.A.#: _____
PYLE PRO Service Center
1600 63rd Street
Brooklyn, NY 11204

You must also include the following items with your return:

- A copy of your sales receipt or other proof of purchase
- A brief letter, indicating the problem you are experiencing with the product
- Include in your letter your return address, daytime phone number and R.A. number
- Also include a check or money order for \$15.00 for return shipping, handling and insurance, or provide your Visa/MC number with expiration date.

Our obligation under this warranty is limited to the repair or replacement of the defective unit when it is returned to us prepaid. This warranty will be considered void if the unit was tampered with, improperly serviced or subject to misuse, neglect or accidental damage.



Place
Stamp
Here

▶ Please complete warranty card, detach and return ▶



Free Manuals Download Website

<http://myh66.com>

<http://usermanuals.us>

<http://www.somanuals.com>

<http://www.4manuals.cc>

<http://www.manual-lib.com>

<http://www.404manual.com>

<http://www.luxmanual.com>

<http://aubethermostatmanual.com>

Golf course search by state

<http://golfingnear.com>

Email search by domain

<http://emailbydomain.com>

Auto manuals search

<http://auto.somanuals.com>

TV manuals search

<http://tv.somanuals.com>