

PYRAMID[®]



OWNER'S MANUAL

PB-101 • PB-251 • PB-301 • PB-601

INTRODUCTION

Thank you for purchasing the Pyramid **ARCTIC SERIES** High Speed Power Amplifier. The **AMPLIFIER** has been designed using the latest electronic technology available.

The **AMPLIFIER** is with engineered features allowing you to produce high quality stereo reproduction in mobile applications. This innovative system has been designed a 12 volts DC negative ground power supply. Easy installation with mounting hardware is provided.

PB-101

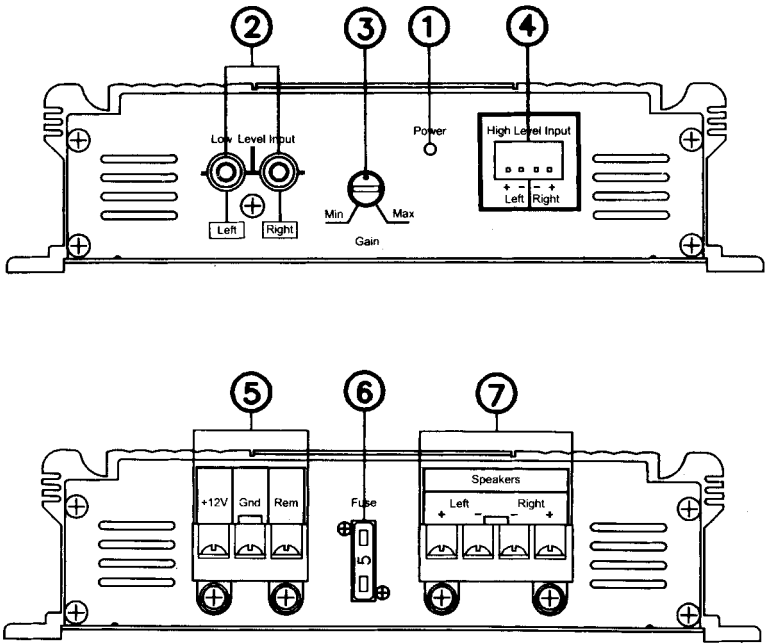

1. Power On LED
2. Low Level Input
3. Input Gain Control

4. High Level Input
5. Power Supply
6. Power Fuse
7. Speaker Output Terminals

INTRODUCTION

PB-251

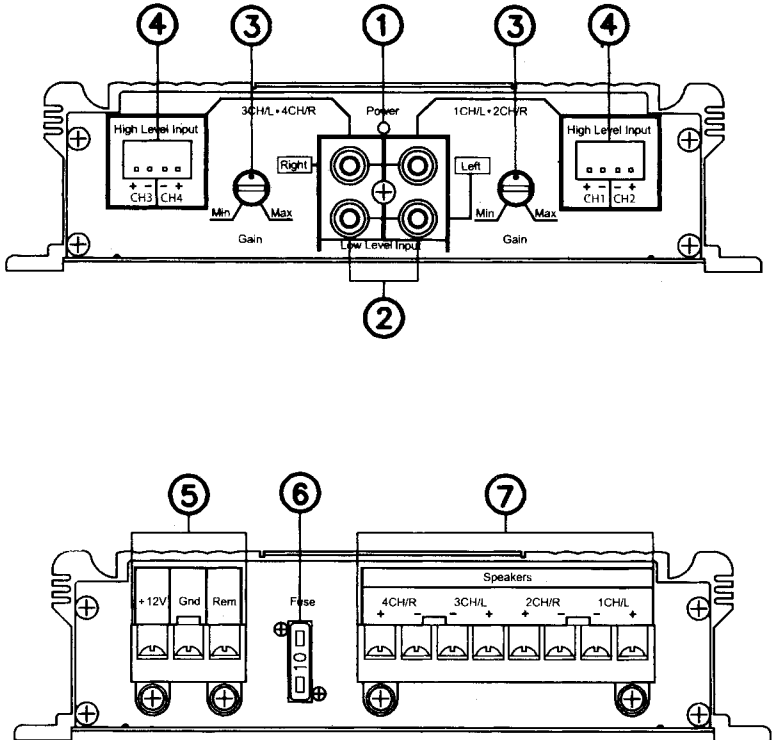

1. Power On LED
2. Low Level Input
3. Input Gain Control

4. High Level Input
5. Power Supply
6. Power Fuse
7. Speaker Output Terminals

INTRODUCTION

PB-301

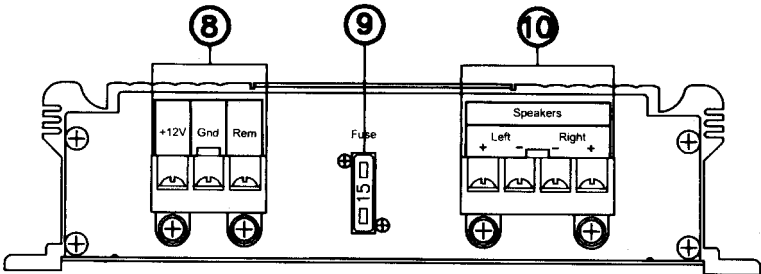
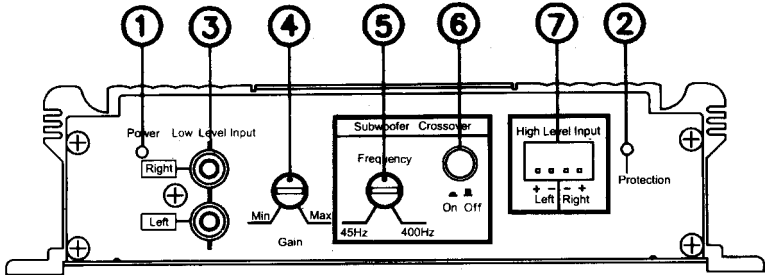

1. Power On LED
2. Protection LED
3. Low Level Input
4. Input Gain Control
5. Subwoofer Crossover Frequency Control
6. Subwoofer Crossover On/Off Switch
7. High-Level Input
8. Power Supply
9. Power Fuse
10. Speaker Output Terminals

INTRODUCTION

PB-601

The **PB-601** utilizes **8 MOSFETS 2 TRANSFORMER** in its design to produce enough voltage to supply the main amplifier and a huge considerable amount of reserve voltage for peak "high demand" situations.

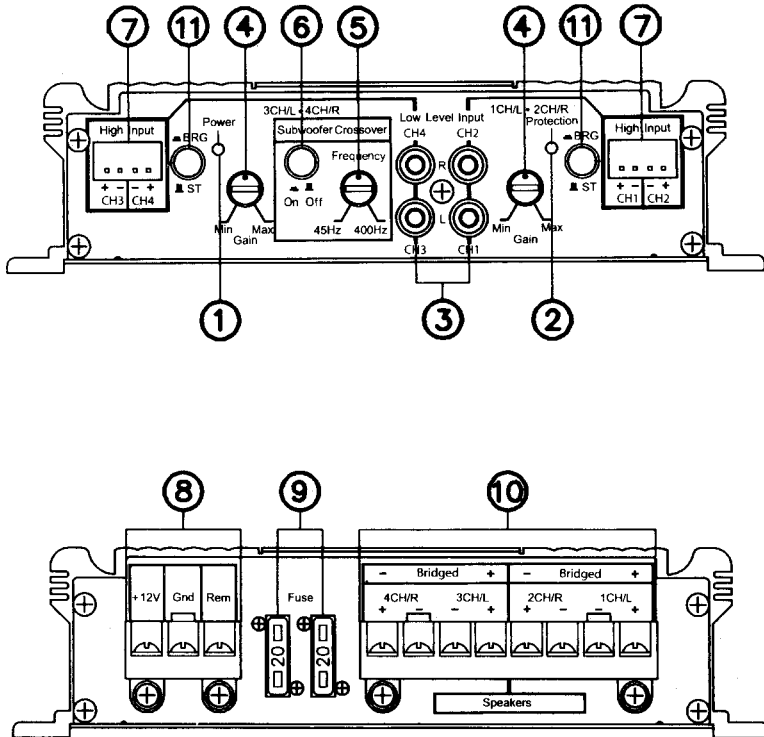

- | | |
|--|------------------------------|
| 1. Power On LED | 7. High-Level Input |
| 2. Protection LED | 8. Power Supply |
| 3. Low Level Input | 9. Power Fuse |
| 4. Input Gain Control | 10. Speaker Output Terminals |
| 5. Subwoofer Crossover Frequency Control | 11. Bridged Mode Switch |
| 6. Subwoofer Crossover On/Off Switch | |

1. POWER ON LED

Lights up when the remote on system is energized.

2. LOW LEVEL INPUT (HIGH IMPEDANCE)

This unit is provided with gold plated RCA input Jacks for High impedance input. Couple the RCA input with the car stereo output using RCA type connector cables.

3. GAIN CONTROL

Adjusting the control will match the output of the stereo to the amplifier. Turn the control clockwise for more volume and counter-clockwise for less volume. If there is distortion when the volume of stereo is turned up, turn the control down.

4. HIGH LEVEL INPUT (LOW IMPEDANCE)

If your car stereo does not have RCA output jacks, you can connect the speaker output from the stereo system to the amplifier.

5. POWER SUPPLY

A. +12V

To connect +12V DC power supply wire from the terminal of the battery.

B. GROUND

To connect the ground wire from the chassis of the automobile.

C. REMOTE

To connect the control wire which provides remote turn on and off of the amplifier by the radio/cassette player. (Usually The Auto Antenna Lead)

6. POWER FUSE

The power fuse protects both this amplifier and the automobile electrical system from short circuit conditions.

7. SPEAKER TERMINALS

The speaker terminals are 14K Gold Plated for high conductivity and minimum impedance loss. The terminals are facing upwards for easy wiring in tight situations. Be sure to strip just enough insulation off your speaker wires that will fit under the screw plate to help ensure against speaker wire short circuit.

A. HIGH IMPEDANCE INPUT CONNECTION

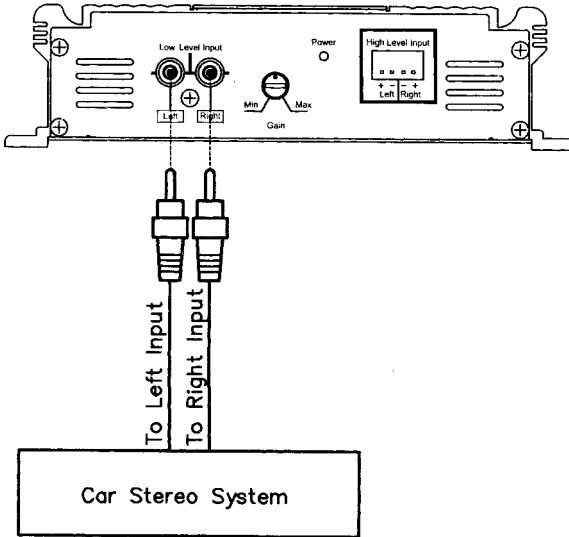

B. LOW IMPEDANCE INPUT CONNECTION

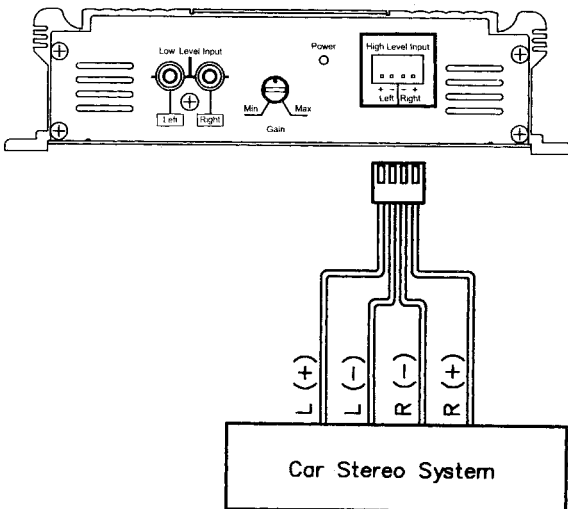

NOTE: THE ABOVE TYPES OF INPUT MUST BE USED INDEPENDENTLY. DO NOT CONNECT MORE THAN ONE INPUT AT THE SAME TIME.

C. SPEAKERS CONNECTIONS

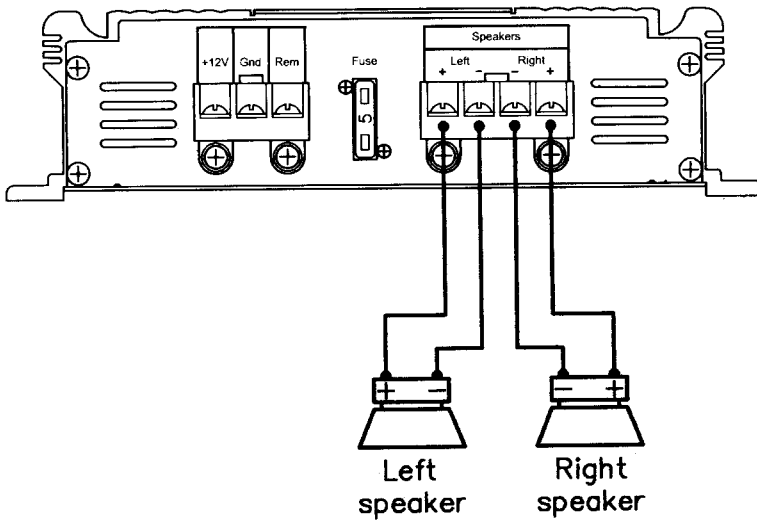

D. POWER CONNECTION

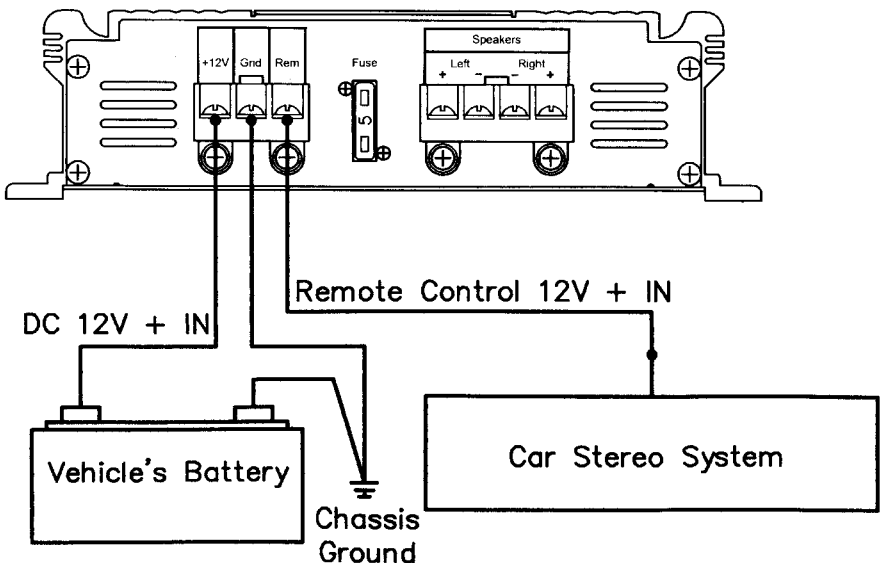

A. STEREO INPUT CONNECTION

- **NOTE:** Do not use both low and high level inputs simultaneously!

RCA TYPE TERMINAL

This amplifier is provided with gold plated **RCA** terminals for **LOW LEVEL INPUT** to match radios and equalizers with line level output. (Fig. 1A)
If your **STEREO** has only **RIGHT** and **LEFT** outputs then you must use a Y-adaptor connecting the stereo to the amplifier as indicated. (Fig. 1B)

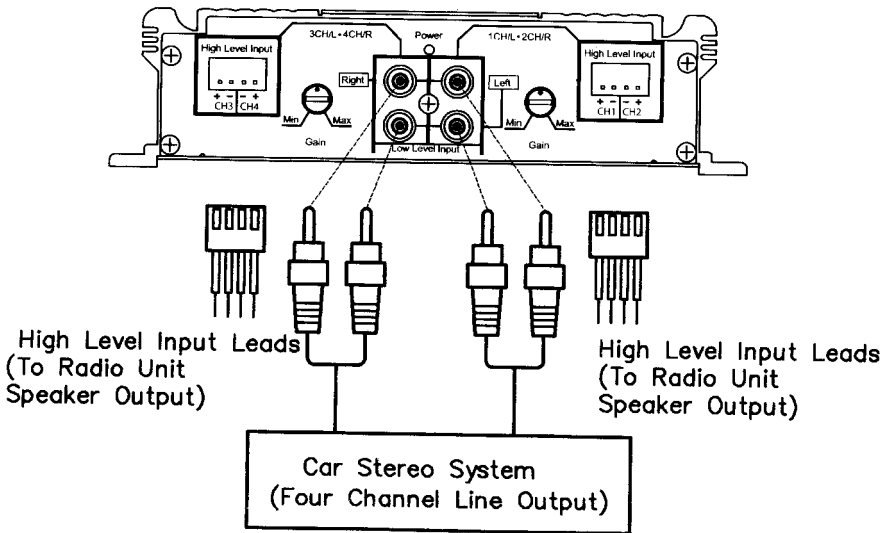

(Fig. 1A)

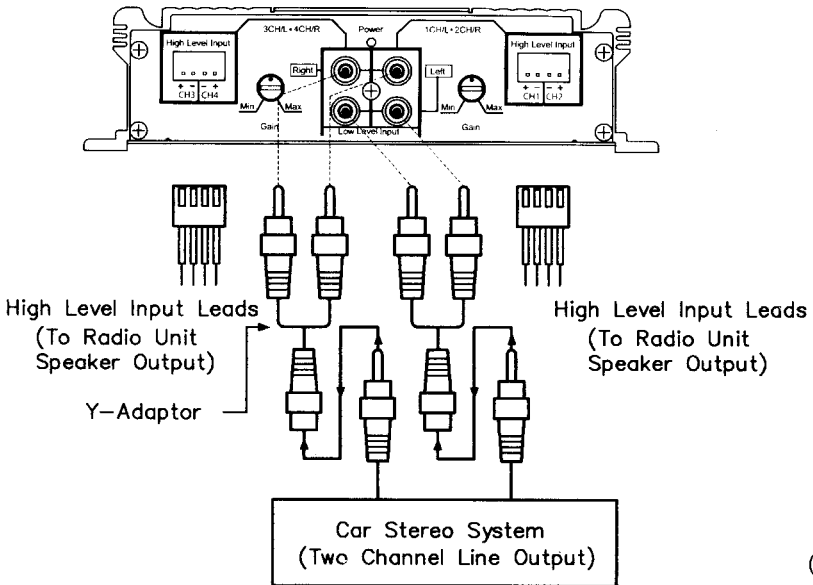

(Fig. 1B)

B. CONNECTING THE SPEAKERS

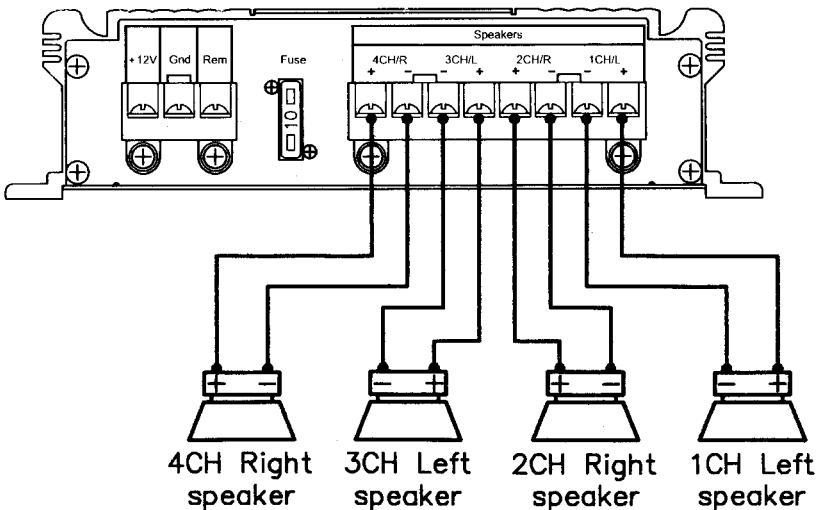

C. POWER CONNECTION

1. Connect the B + 12V pole of power supply directly to the battery (+) position terminal.
2. Connect the GND pole of power supply directly to the (-) negative ground battery terminal or car chassis.
3. To make a good grounding and prevent motor boating noise problem connect another 12 gauge minimum wire from the (-) negative battery terminal to chassis of stereo unit.
4. Connect the 'Remote' pole to external switch for positive 12V ON/OFF. This may be connected to the receiver power antenna lead.

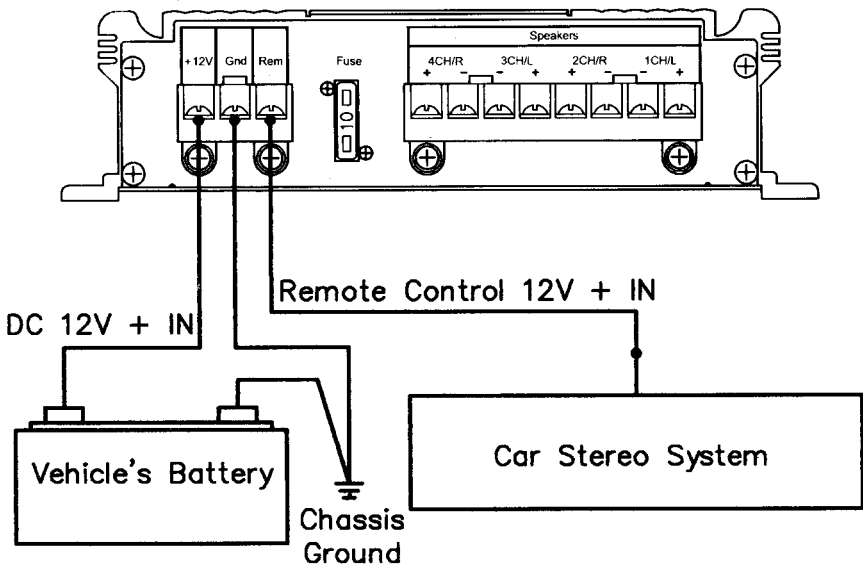

1. POWER ON LED

Lights up when the remote on system is energized.

2. PROTECTION LED

The protection circuitry will disable the amplifier if it senses an input overload, speaker short circuit or extreme high temperature conditions. When the protection circuit is in operation the LED indicator on the unit will light indicating that the amplifier has gone into a self preservation mode. At this time please check your system to see what is causing the protection circuit to fire. The amplifier can be reset by turning the remote power off and then on again. If the system shuts down because of a thermal overload condition, allow the amplifier to cool down before restarting. If the amplifier shutdown because of an input overload or speaker short circuit please be sure to correct these conditions before restarting the amplifier.

3. LOW LEVEL INPUT (HIGH IMPEDANCE)

This unit is provided with gold plated **RCA** input Jacks for High impedance input. Couple the **RCA** input with the car stereo output using **RCA** type connector cables.

4. GAIN CONTROL

Adjusting the control will match the output of the stereo to the amplifier. Turn the control clockwise for more volume and counter-clockwise for less volume. If there is distortion when the volume of stereo is turned up, turn the control down.

5. CROSSOVER FREQUENCY CIRCUIT

Lets you adjust the crossover frequency from 45-400 Hz for both channels.

6. CROSSOVER FREQUENCY ON/OFF SWITCH

Let you set the amplifier to drive a connected subwoofer.

7. HIGH LEVEL INPUT (LOW IMPEDANCE)

If your car stereo does not have **RCA** output jacks, you can connect the speaker output from the stereo system to the amplifier.

8. POWER SUPPLY

A. +12V

To connect +12V DC power supply wire from the terminal of the battery.

B. GROUND

To connect the ground wire from the chassis of the automobile.

C. REMOTE

To connect the control wire which provides remote turn on and off of the amplifier by the radio/cassette player. (Usually The Auto Antenna Lead)

9. POWER FUSE

The power fuse protects both this amplifier and the automobile electrical system from short circuit conditions.

10. SPEAKER TERMINALS.

The speaker terminals are 14K Gold Plated for high conductivity and minimum impedance loss. The terminals are facing upwards for easy wiring in tight situations. Be sure to strip just enough insulation off your speaker wires that will fit under the screw plate to help ensure against speaker wire short circuits.

11. TRI-MODE BRIDGING CAPABILITY. (PB-601)

The Amplifier can be bridged into the following systems.

A. Three channel Mode. Bridge Channels 3 & 4 into one high power channel for subwoofer application while leaving channels 1 & 2 in the stereo mode for satellite components.

B. Two Channel Mode. Bridge channels 1 & 2 into one high powered channel. Bridge channels 3 & 4 into a second high powered channel. Be sure to utilize speakers which can handle at least 100 Watts **RMS** on the bridged channels.

12. MUTE TURN ON CIRCUIT

The Amplifier features an anti-thump delay circuit. This circuit eliminates irritating thump noises some times experienced with cheaper amplifiers when they are turned on.

A. HIGH IMPEDANCE INPUT CONNECTION

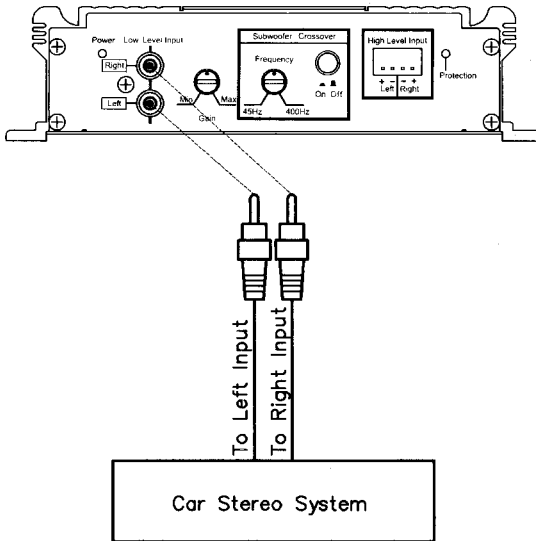

B. LOW IMPEDANCE INPUT CONNECTION

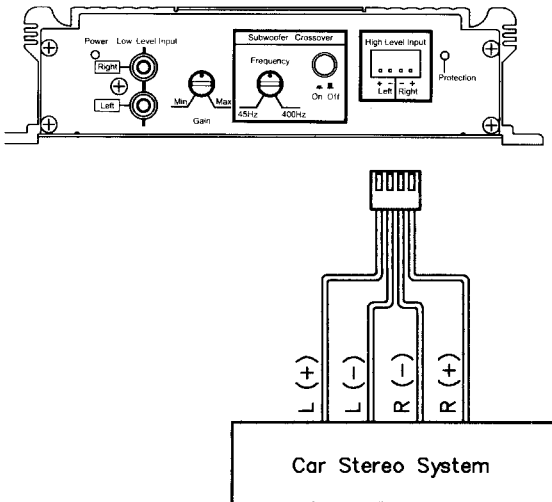

NOTE: THE ABOVE TYPES OF INPUT MUST BE USED INDEPENDENTLY. DO NOT CONNECT MORE THAN ONE INPUT AT THE SAME TIME.

C. SPEAKER CONNECTIONS

You do not need to make any adjustment for the input connection of Amplifier before you connect the speaker output.

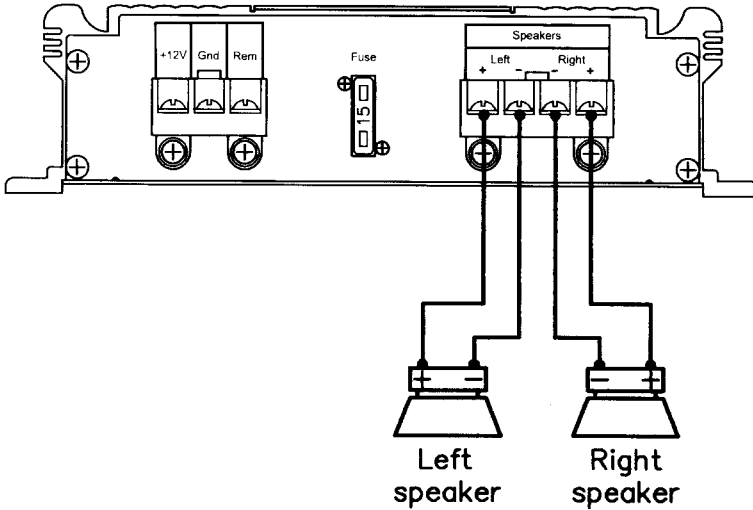

D. POWER CONNECTION

1. Connect the B +12V pole of power supply directly to the battery (+) position terminal.
2. Connect the **GND** pole of power supply directly to the (-) negative ground battery terminal or car chassis.
3. To make a good grounding and prevent motor boating noise problem connect another 12 gauge minimum wire from the (-) negative battery terminal to chassis of stereo unit.
4. Connect the 'Remote' pole to external switch for positive 12V **ON/OFF**. This may be connected to the receiver power antenna lead.

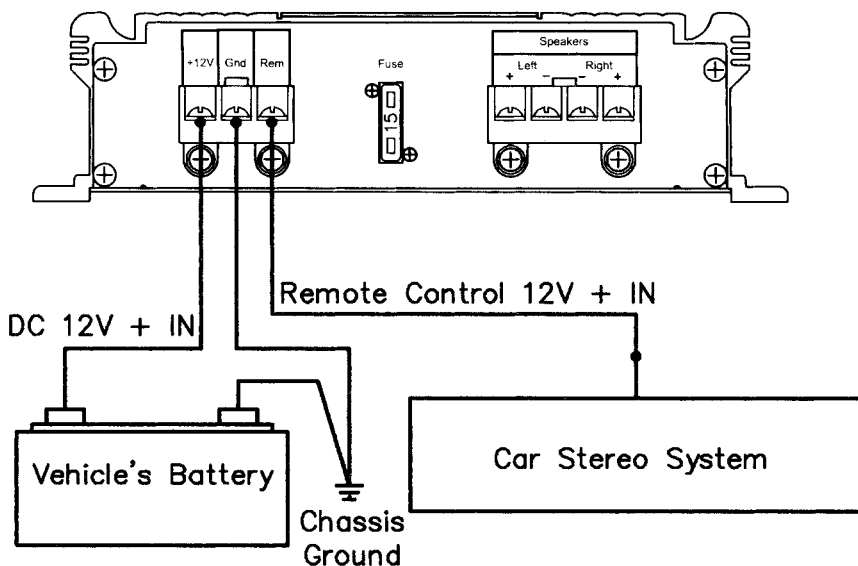

A. STEREO INPUT CONNECTION

- **NOTE:** Do not use both low and high level inputs simultaneously!

RCA TYPE TERMINAL

This amplifier is provided with gold plated **RCA** terminals for **LOW LEVEL INPUT** to match radios and equalizers with line level output. (Fig. 1A)
If your **STEREO** has only **RIGHT** and **LEFT** outputs then you must use a Y-adaptor connecting the stereo to the amplifier as indicated. (Fig. 1B)

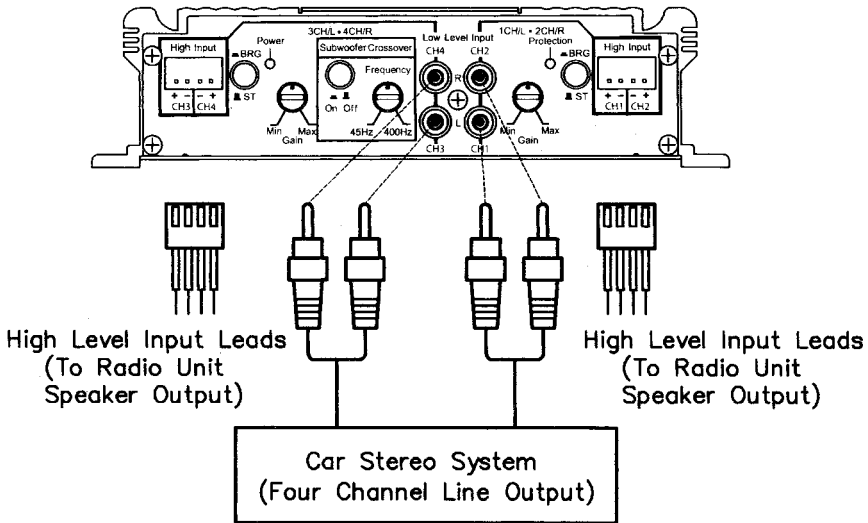

(Fig. 1A)

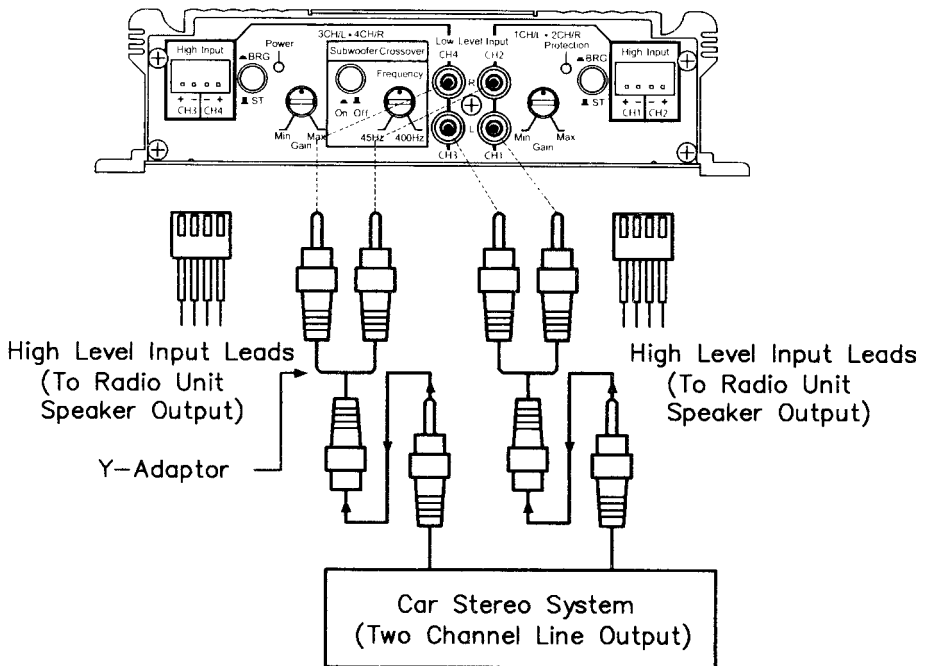

(Fig. 1B)

WHEN YOU WANT TO BRIDGE THE AMPLIFIER PLEASE COMPLETE THE FOLLOWING STEPS.

1. Push the **BRIDGED/STEREO** switch the **BRIDGED** position.
2. If your **STEREO** only use **RIGHT** and **LEFT** outputs, please wire as (Fig. 2A)
3. If your **STEREO** has four channel outputs please wire as (Fig. 2B).

NOTE: Do not use both low and high level inputs simultaneously!

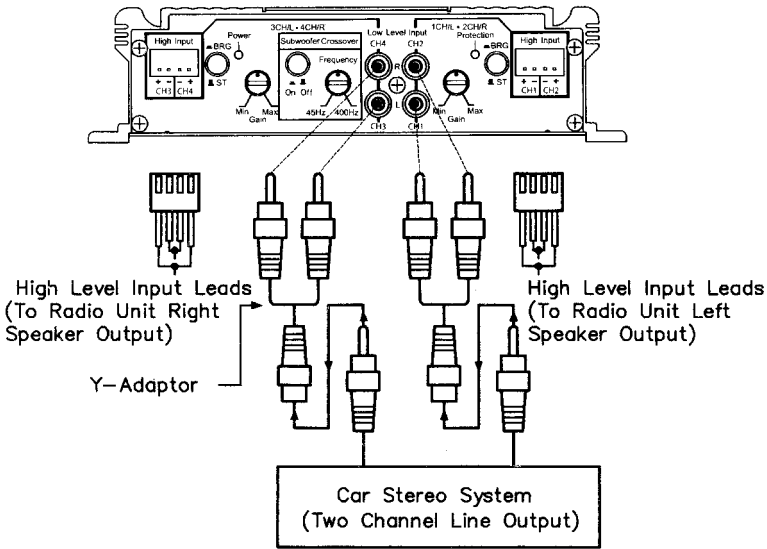

(Fig. 2A)

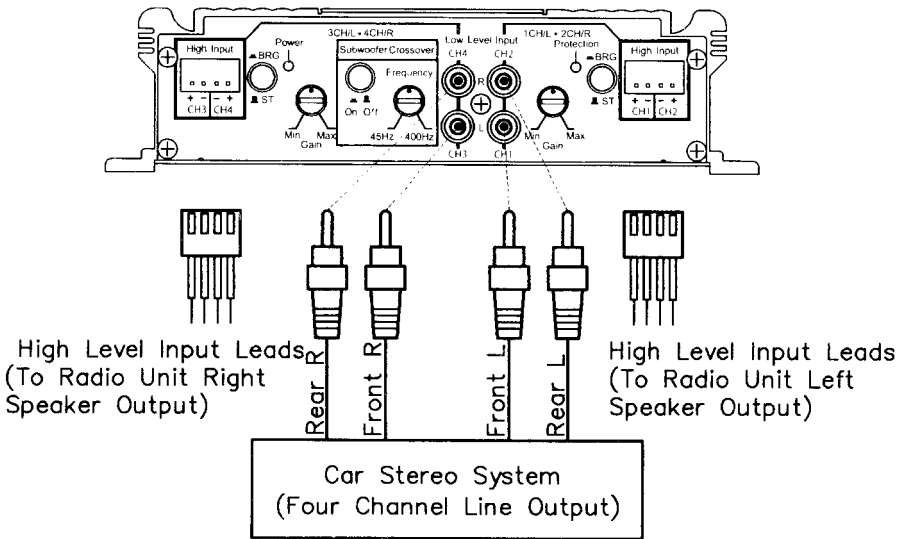

(Fig. 2B)

B. SPEAKER CONNECTIONS

You do not need to make any adjustment for the input connection of Amplifier before you connect the speaker output.

1.4 Channel Output Mode

Connect the speaker output terminals to the corresponding speaker. (Fig. 3A)

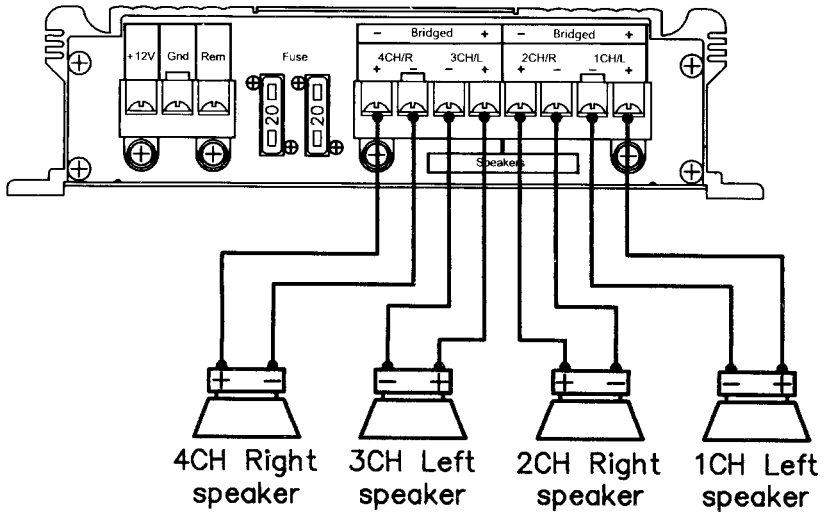

(Fig. 3A)

2. 2 Channel Output Mode

You may want to bridge the Amplifier to a 2 **CHANNEL** output amplifier. Push the bridge switch of 1-2CH and 3-4CH to the bridged position and use high quality speakers which are capable of handling the high power output. In this mode only the 1-2CH and 3-4CH speaker will be activated. (Fig. 3B)

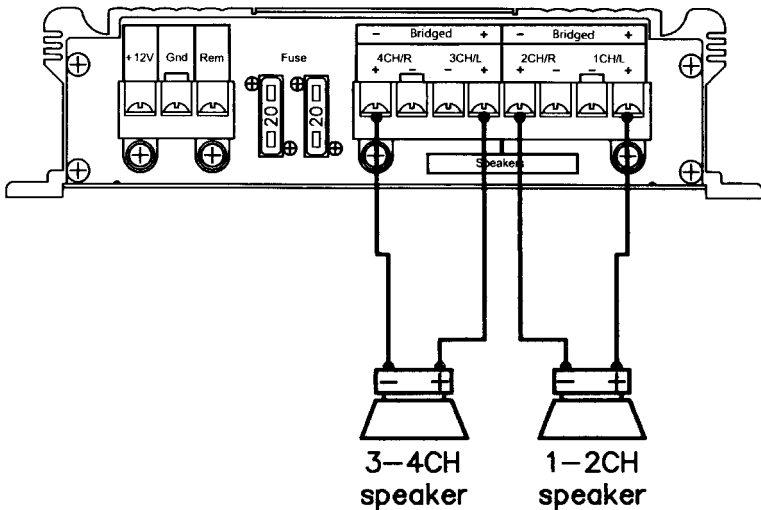

(Fig. 3B)

C. 2-CHANNEL STEREO OUTPUT COMBINED WITH MONO SUBWOOFER OUTPUT MODE

Push the Bridge/Stereo switch of 3-4CH to the bridged position.

(a) SUBWOOFER

Connect the speaker to the 3-4CH speaker terminal.

(b) 2-CHANNEL STEREO

The **RIGHT** signal output from 2-RIGHT speaker terminal.

The **LEFT** signal output from 1-LEFT speaker terminal.

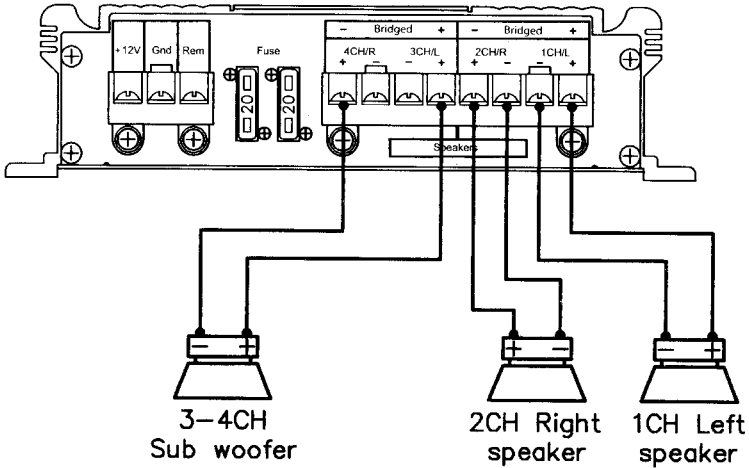

D. POWER CONNECTION

1. Connect the B + 12V pole of power supply directly to the battery (+) position terminal.
2. Connect the GND pole of power supply directly to the (-) negative ground battery terminal or car chassis.
3. To make a good grounding and prevent motor boating noise problem connect another 12 gauge minimum wire from the (-) negative battery terminal to chassis of stereo unit.
4. Connect the 'Remote' pole to external switch for positive 12V ON/OFF. This may be connected to the receiver power antenna lead.

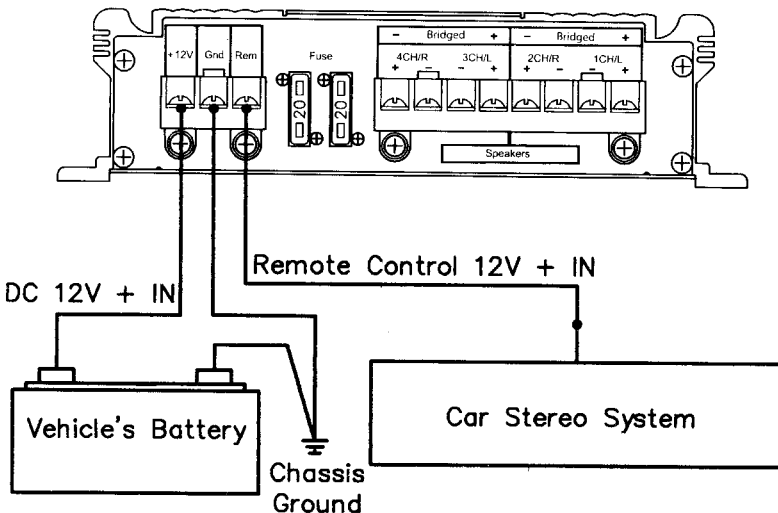

INSTALLATION

The Amplifier comes complete with all mounting hardware. While the Amplifier can be mounted in any convenient location in your vehicle, please remember that this is a high power unit which generates high electrical energy and heat. Therefore be sure to install the unit in a place with sufficient airflow, a minimum of dust and no moisture. Allow enough space around the cooling fins to permit reasonable airflow and cooling.

Choose a suitable location to mount the amplifier so that it is protected from vibration.

Check clearance all around the amplifier be sure to leave enough room for wiring.

Secure the amplifier tightly. Do not leave an unmounted amplifier in your car trunk or deck as it can be a driving hazard should you be forced to make a short stop.

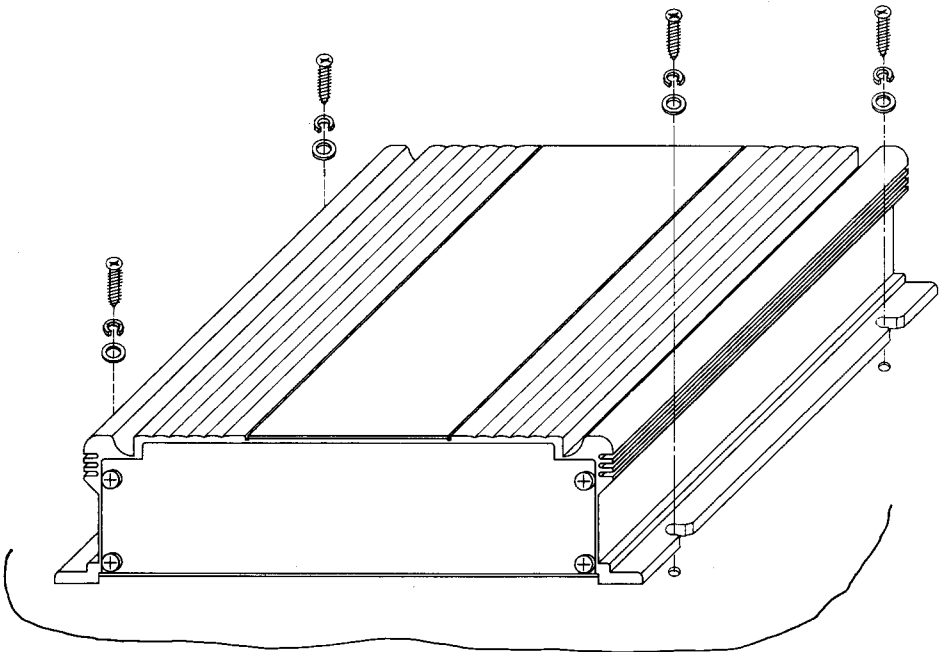

TESTING AND SPECIFICATIONS

1. After all the connections have been made, turn on your stereo and listen for the amplifier to turn on. If there are any unusual noises from the speakers then turn the system off and recheck all the wiring.
2. After you have connected your radio or equalizer to the amplifier, you may adjust the gain control to match the output level of your radio.
 - (A) Set the volume control on your radio to 2/3 position.
 - (B) Adjust the gain control for an average listening level.
 - (C) Turn the radio volume all the way down and listen for background noise.
 - (D) Start your vehicle and listen for electrical noise.
 - (E) Making fine adjustments to the sensitivity can reduce background noise and some engine noise.
 - (F) **CAUTION:** Never turn the sensitivity up any farther than you need to get clear sound at 2/3 volume.
 - (G) This adjustment only needs to be made once.

SPECIFICATIONS

1. Output Power
@ 14.4 V.DC. 1 KHz PB-101 : 120W × 2 MAX
PB-251 : 75W × 4 MAX
PB-301 : 150W × 2 MAX
PB-601 : 150W × 4 MAX
2. Bridged Mode PB-601 : 300W × 2 or 150W × 2 and 300W × 1
3. Frequency Response 10-30,000 Hz (± 3 dB)
4. Input Impedance 10K Ohms (Low Level)
100 Ohms (High Level)
5. Input Sensitivity 250mV (Low Level)
2.5V (High Level)
6. Power Supply Voltage DC 14.4 Negative Ground (10.5-16V)
7. Matching Speaker Impedance 4-8 Ohms
8. Maximum Current Draw PB-101 : 5A
PB-251 : 10A
PB-301 : 15A
PB-601 : 40A
9. Dimensions PB-101 : 200 × 50 × 159 mm (W × H × D)
PB-251 : 200 × 50 × 220 mm (W × H × D)
PB-301 : 200 × 50 × 245 mm (W × H × D)
PB-601 : 200 × 50 × 406 mm (W × H × D)
10. Net Weight PB-101 : 1.10 Kgs
PB-251 : 1.60 Kgs
PB-301 : 1.80 Kgs
PB-601 : 3.00 Kgs

Free Manuals Download Website

<http://myh66.com>

<http://usermanuals.us>

<http://www.somanuals.com>

<http://www.4manuals.cc>

<http://www.manual-lib.com>

<http://www.404manual.com>

<http://www.luxmanual.com>

<http://aubethermostatmanual.com>

Golf course search by state

<http://golfingnear.com>

Email search by domain

<http://emailbydomain.com>

Auto manuals search

<http://auto.somanuals.com>

TV manuals search

<http://tv.somanuals.com>