



AcousticDesign™ Multi-Use Loudspeaker

## AD-S52 and AD-S52T

All-Weather 133 mm (5.25") two-way with shielded woofer and neodymium tweeter  
"T" suffix models: 70V/100V transformer equipped (bypassable)

User Manual

EN

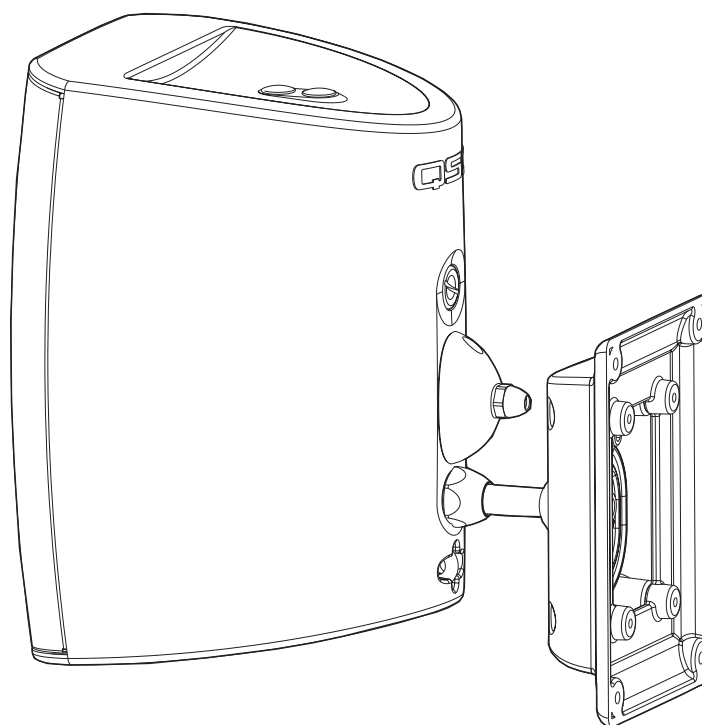
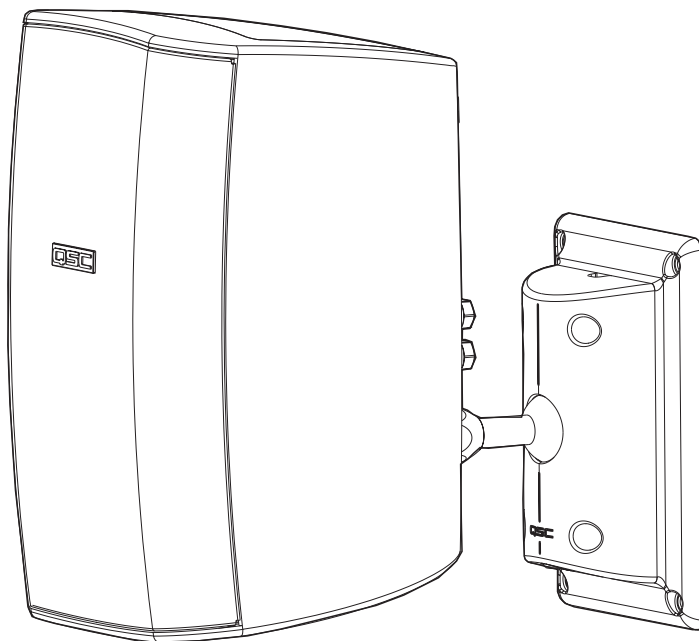

TD-000139-00 rev.A



## IMPORTANT SAFETY PRECAUTIONS & EXPLANATION OF SYMBOLS

- 1- Read these instructions.
- 2- Keep these instructions.
- 3- Heed all warnings.
- 4- Follow all instructions.
- 5- Clean only with a dry cloth.
- 6- Install in accordance with QSC Audio Product's instructions and a licensed, professional engineer.
- 7- Do not install near any heat sources such as radiators, heat registers, stoves, or other apparatus (including amplifiers) that produce heat.
- 8- Only use attachments/accessories from QSC Audio Products, Inc.
- 9- Use only with mounts or brackets specified by QSC Audio Products.
- 10- Refer all servicing to qualified personnel. Servicing is required when the apparatus has been damaged in any way.



The lightning flash with arrowhead symbol within an equilateral triangle is intended to alert the user to the presence of uninsulated "dangerous" voltage within the product's enclosure that may be of sufficient magnitude to constitute a risk of electric shock to humans.



The exclamation point within an equilateral triangle is intended to alert the user to the presence of important operating and maintenance (servicing) instructions in this manual.



**WARNING!** Before placing, installing, rigging, or suspending any speaker product, inspect all hardware, suspension, cabinets, transducers, brackets and associated equipment for damage. Any missing, corroded, deformed or non-load rated component could significantly reduce the strength of the installation, placement, or array. Any such condition severely reduces the safety of the installation and should be immediately corrected. Use only hardware which is rated for the loading conditions of the installation and any possible short-term unexpected overloading. Never exceed the rating of the hardware or equipment. Consult a licensed, professional engineer when any doubt or questions arise regarding a physical equipment installation.

### **Warranty (USA only; other countries, see your dealer or distributor)**

#### **Disclaimer**

QSC Audio Products, Inc. is not liable for any damage to amplifiers, or any other equipment that is caused by negligence or improper installation and/or use of this loudspeaker product.

#### **QSC Audio Products 3 Year Limited Warranty**

QSC Audio Products, Inc. ("QSC") guarantees its products to be free from defective material and / or workmanship for a period of three (3) years from date of sale, and will replace defective parts and repair malfunctioning products under this warranty when the defect occurs under normal installation and use - provided the unit is returned to our factory or one of our authorized service stations via pre-paid transportation with a copy of proof of purchase (i.e., sales receipt). This warranty provides that the examination of the return product must indicate, in our judgment, a manufacturing defect. This warranty does not extend to any product which has been subjected to misuse, neglect, accident, improper installation, or where the date code has been removed or defaced. QSC shall not be liable for incidental and/or consequential damages. This warranty gives you specific legal rights. This limited warranty is freely transferable during the term of the warranty period.

Customer may have additional rights, which vary from state to state.

In the event that this product was manufactured for export and sale outside of the United States or its territories, then this limited warranty shall not apply. Removal of the serial number on this product, or purchase of this product from an unauthorized dealer, will void this limited warranty.

Periodically, this warranty is updated. To obtain the most recent version of QSC's warranty statement, please visit [www.qscaudio.com](http://www.qscaudio.com).

Contact us at 800-854-4079 or visit our website at [www.qscaudio.com](http://www.qscaudio.com).

© Copyright 2003, QSC Audio Products, Inc.

QSC® is a registered trademark of QSC Audio Products, Inc.

"QSC" and the QSC logo are registered with the U.S. Patent and Trademark Office

## Introduction

Thank you and congratulations on your purchase of the AcousticDesign AD-S52 multi-use, weather resistant loudspeakers. These products represent the state-of-the-art in all-weather, lightweight SR (sound reinforcement) loudspeaker systems. To get the most from your investment, we encourage you to review this manual carefully.

The AD-S52 loudspeaker systems are full range, high output, two-way designs delivering superior sound quality and high SPL in a lightweight, weather resistant enclosure. The low frequency driver is magnetically shielded and the neodymium high frequency driver has very little stray magnetic field, making the AD-S82 perfect for use near video monitors. The included ball mount provides secure and versatile installation. These loudspeakers make an excellent choice for a wide variety of SR applications.

AD-S52T models have a 70V/100V matching transformer and tap selector switch. The transformer may be bypassed.

The illustration (at right) highlights product features:

- 1- two sets of threaded inserts for optional YM-5 yoke mount
- 2- transformer tap selector (AD-S52T model only)
- 3- binding post input terminals (weather resistant cover removed)
- 4- ball mount attachment point (ball mount removed)
- 5- safety cable attachment point

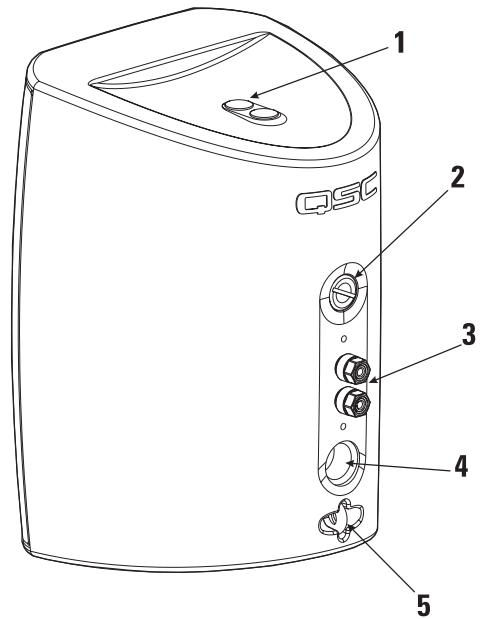

## What's Included

The carton contains:

- AD-S52 (or AD-S52T) loudspeaker assembly (2 each)
- Ball mount assembly (2 each)
- 6 mm hex key (Allen wrench)
- Input cover (2 each)
- Input cover gasket (2 each, may be part of cover)
- Input strain relief bushing (2 each, may be part of cover)
- M4 x 1.4 x 15 mm long pan head Phillips screw (4 ea., for covers)
- This User Manual

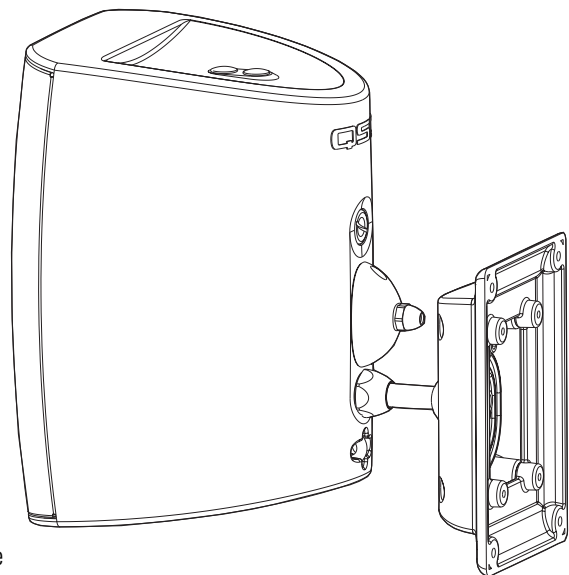

## Mounting

### Stand Alone Mounting

If using the loudspeaker only (no ball mount or optional yoke mount) the loudspeaker can be set on any appropriate surface. The cabinet will lean back at a slight angle when set on a flat surface.

When operated at high output levels, the cabinet can vibrate, causing the cabinet to move or creep if set on a hard surface. Use anti-slip matting under the cabinet or self-adhesive rubber feet to keep the cabinet from creeping.

### Safety Cable Attachment

On the back of the loudspeaker, near the bottom, is a safety cable attachment point. Install a safety cable strong enough to support several times the weight of the loudspeaker assembly in the event it may fall. The cable must be secured to a secondary support point which is also strong enough to support several times the loudspeaker's weight.

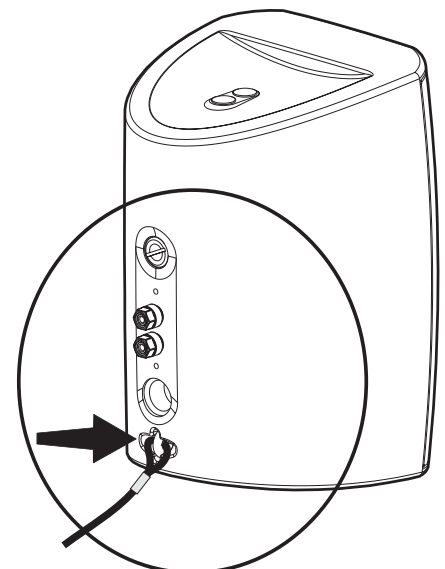

Attach safety cable here.



**IMPORTANT! ENSURE THAT THE LOUDSPEAKER IS MOUNTED PROPERLY AND A SAFETY CABLE IS INSTALLED TO RETAIN THE LOUDSPEAKER IN THE EVENT OF A MOUNTING FAILURE.**

## Mounting (continued)

### Ball Mount Adapter

The included ball mount adapter can be attached to almost any flat surface. The ball mount adapter's back plate can be removed, if desired. This will reduce the overall depth of the assembly and the footprint of the mount on the wall.

To use the wall mount adapter, secure to the mounting surface using four screws. Ensure the mounting surface is sufficiently strong to support the loudspeaker and any vibration or seismic activity. Connect the wiring to the loudspeaker and install the terminal cover, if desired. Thread the adapter into the threaded insert on the bottom of the loudspeaker. Adjust the angle of the loudspeaker and tighten the hardware fully. We recommend 12 lbs.-ft (15 N-m) of tightening torque be applied to both fasteners.

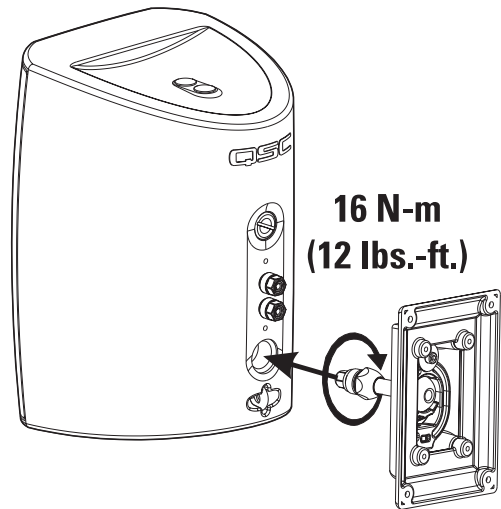

### Optional Yoke Mount

There is an optional yoke mount available, model YM-5. Contact your QSC Audio Products representative for details.

## Connection

### AD-S52 or AD-S52T?

Connection is the same for both models, but for the AD-S52T you must set the transformer Tap Selector Switch to the appropriate setting before applying audio.

### Terminations

The binding post terminals will accept:

- bare wire (up to 0.15" or 3.8 mm diameter)
- spade lug terminals
- banana plugs (singles or dual 0.75" spaced)

### Input Connection Cover (wire termination only)

The loudspeaker includes a weather resistant cover for the input terminals. For proper sealing, the cable jacket must be round (or close to round) and be between 0.12" (3mm) and 0.25" (6.3mm) outside diameter.

- Pass the wires through the compression nut, gasket, and cover.
- Loosen the binding post nuts.
- Strip the wires and insert into binding posts.
- Tighten nuts.
- Slide the cover over the terminals and secure using the two machine screws provided.
- Ensure gasket is seated properly; tighten compression nut.

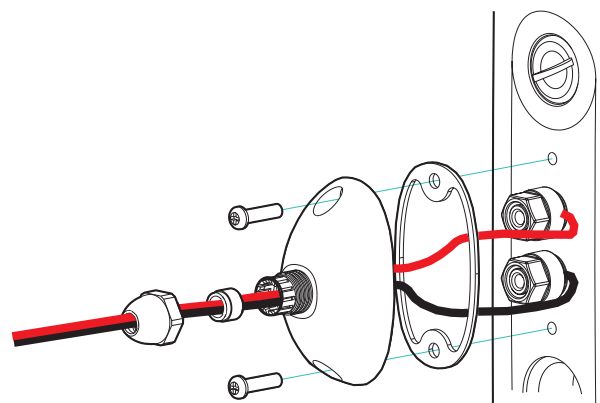
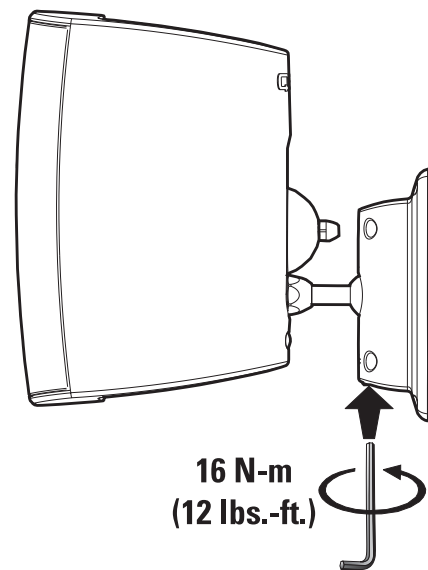

**To assure weather-tight connections, make sure the Input Cover fits flush against the loudspeaker cabinet, all gaskets are properly placed, and hardware is tightened sufficiently. Use of the Input Cover may require the use of smaller wire sizes for proper fit.**



**NOTE! You cannot use banana type connectors or spade lugs when the Input Connection Cover is used. Connect the wires directly to the terminals when using the Input Cover.**

## Wiring

Connect the amplifier's + and - outputs directly to the loudspeaker's + (red) and - (black) terminals. The binding post terminals accept wire, spade terminals, or banana plugs. Use only wire connections when using the Input Cover. The terminals are spaced 0.75" (19 mm).



**Maintain proper speaker and amplifier connection polarity throughout the entire system. All positive-marked loudspeaker terminals should be connected to positive-marked amplifier output terminals. This will provide the best possible low-frequency output from your system.**

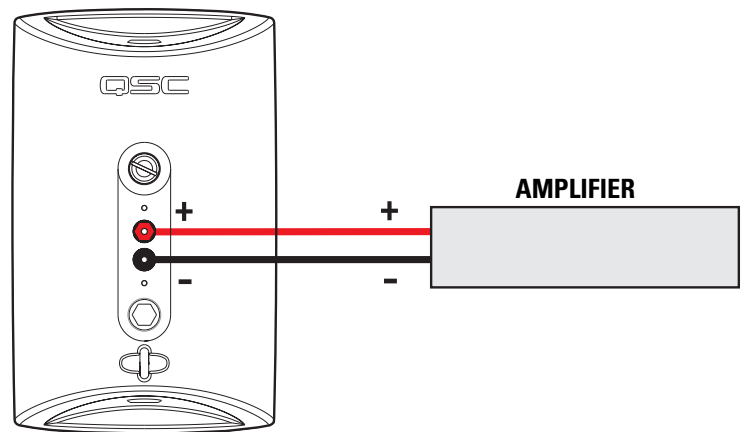

EN

## AD-S52T 70V/100V Transformer Tap Selection

AD-S52T models are equipped with a 70V/100V matching transformer for distributed audio systems. There is a transformer tap selector switch on the rear panel for setting the power level of the loudspeaker. The switch may also be set for 8 ohm operation, bypassing the transformer completely.

To select the power level, align the slot with the desired power setting number. Use a coin or flat tip screwdriver to operate the switch.

**70V distributed systems:** use the right side markings. Select from 3.75, 7.5, 15, or 30 watts.

**100V distributed systems:** use the left side markings. Select from 7.5, 15, or 30 watts. the "X" position should not be used.



**NOTE! 8 ohm setting should be used for 8 ohm audio systems only. Do not use 8 ohm setting when connecting the AD-S52T loudspeaker to 70V/100V distributed audio systems.**

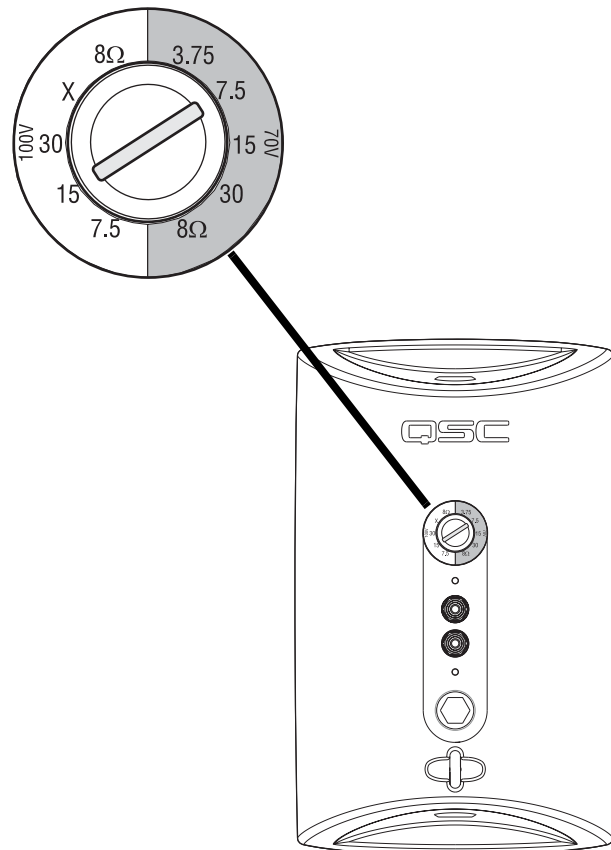

## **Specifications**

<b>Frequency Response:</b>	90- 20k Hz (-6 dB) 70- 21k Hz (-10 dB)
<b>Drivers:</b>	low frequency- 5.25" (133 mm) magnetically shielded high frequency- metallized dome, neodymium magnet structure
<b>Maximum Output:</b> (calculated)	103 dB SPL continuous rms output 106 dB SPL peak output
<b>Impedance:</b>	8 ohms nominal 6.3 ohms minimum, 280 Hz 155 ohms maximum
<b>Power Rating:</b> rms (IEC 100 hrs): recommended amp power:	80 watts rms 160 watts rms
<b>Sensitivity:</b>	91.5 dB, 1 watt, 1 meter, free field (4 pi)
<b>Directivity Index:</b>	500 Hz            3.0 1000 Hz           4.5 2000 Hz           10.7 4000 Hz           6.9 8000 Hz           7.6 16000 Hz          6.2
<b>Q:</b>	500 Hz            1.5 1000 Hz           2.6 2000 Hz           11.3 4000 Hz           6.3 8000 Hz           7.1 16000 Hz          5.2
<b>Weight per pair:</b>	<b>AD-S52:</b> 15 lb. net, 22 lb. shipping <b>AD-S52T:</b> 18 lb. net, 25 lb. shipping
<b>Nominal Coverage:</b>	90° horizontal. x 60° vertical
<b>Enclosure and Grill:</b>	high impact polystyrene, removable metal grill
<b>Connectors:</b>	binding posts (accept up to 0.15" (3.8 mm) diameter wire, banana plugs, or spade lugs)
<b>Mounting Hardware:</b>	<b>Included:</b> ball mount adapter with variable wall plate configurations, alloy construction <b>Optional:</b> yoke mount with retaining knobs (model YM-5)

### **NOTES:**

- 1- All frequency ranges specified refer to measured free-field response (4 pi).
- 2- Calculated maximum peak SPL at 1 m, free-field, speaker operating at rated rms power pink noise input, 50 Hz to 20 kHz.
- 3- Maximum input power tested in accordance with IEC recommendations; 50 Hz to 20 kHz band limiting, 6 dB signal crest factor.

**Specifications are subject to change without notice.**

## Dimensions

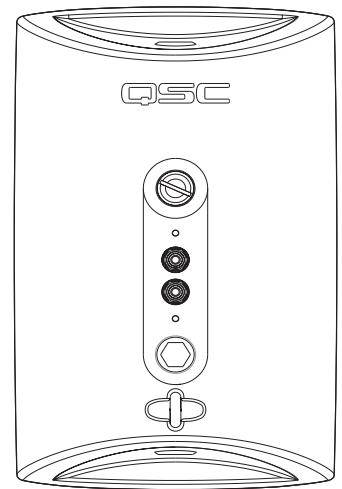
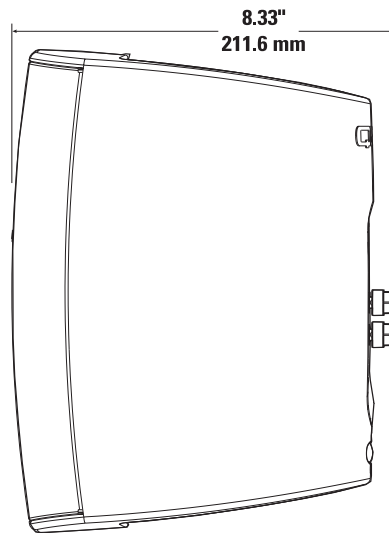
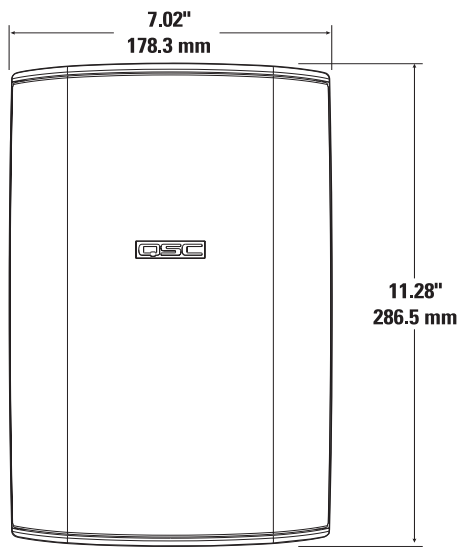

EN

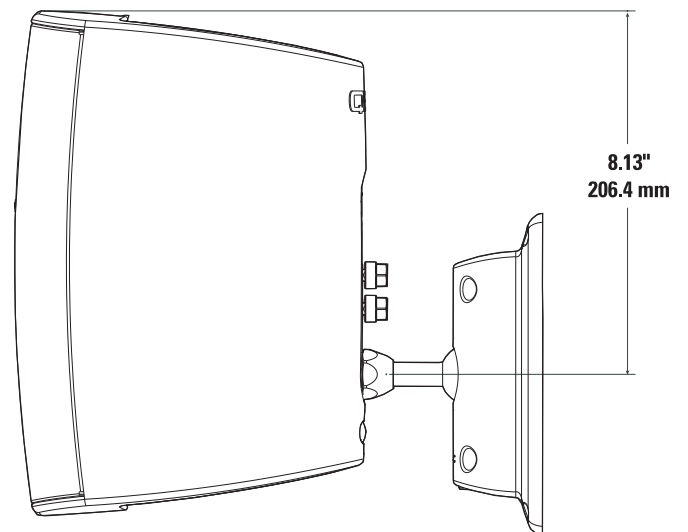
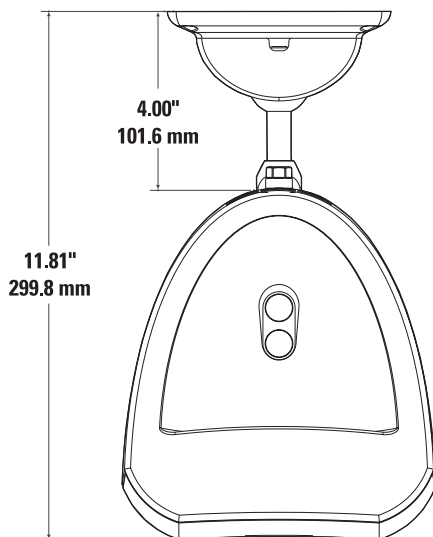
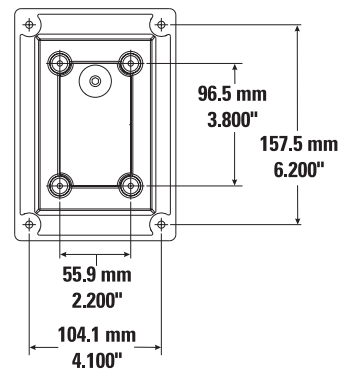
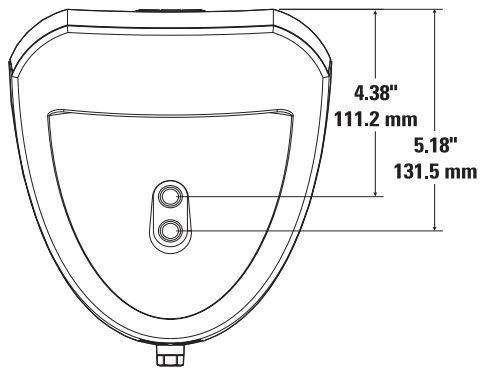

## **Painting the Loudspeaker**

The loudspeaker enclosure, grill, and mount can be painted to match any decor, provided the following precautions are observed. The cabinet is made of high impact polystyrene which requires controlled painting procedures in order to obtain good results. Use a paint "system" designed for high impact polystyrene from any reputable paint supplier.

- 1- Remove the grill.
- 2- If painting mount and loudspeaker as a unit: Attach the ball mount or yoke mount.
- 3- Mask the loudspeaker's input connector.
- 4- Mask the woofer, tweeter, and port being certain not to apply tape directly to the drivers. Alternatively, the inside of the grill can be completely masked and set in place on the loudspeaker enclosure for painting.
- 5- Wash the components to be painted with a mild soap and hot water. Be careful not to get water on or into either of the drivers or the input connections. Rinse with hot water. Allow to dry thoroughly.
- 6- Scuff-sand the components to be painted using red Scotchbrite® pad or 320 - 400 grit sandpaper.
- 7- Using compressed air, remove all dust from the components to be painted. Do not blow compressed air directly into either driver.
- 8- Clean the components to be painted.
- 9- Using a clean, lint-free, white cloth, wipe the components to be painted with suitable prep solution.
- 10- Apply adhesion promoter.
- 11- Apply primer topcoat.
- 12- Apply paint.
- 13- Allow to dry for at least 8 hours before handling.

EN





## How to Contact QSC Audio Products

## Cómo comunicarse con QSC Audio Products

## Comment prendre contact avec QSC Audio Products

## Kontaktinformationen für QSC Audio Products

## 联系 QSC Audio Products



**Mailing address:** QSC Audio Products, Inc.  
1675 MacArthur Boulevard  
Costa Mesa, CA 92626-1468 USA



**Telephone Numbers:**

Main Number	(714) 754-6175
Sales & Marketing	(714) 957-7100 or toll free (USA only) (800) 854-4079
Customer Service	(714) 957-7150 or toll free (USA only) (800) 772-2834



**Facsimile Numbers:**

Sales & Marketing FAX	(714) 754-6174
Customer Service FAX	(714) 754-6173



**World Wide Web:** [www.qscaudio.com](http://www.qscaudio.com)  
**E-mail:** [info@qscaudio.com](mailto:info@qscaudio.com)  
[service@qscaudio.com](mailto:service@qscaudio.com)

# QSC<sup>TM</sup>

QSC Audio Products, Inc. 1675 MacArthur Boulevard Costa Mesa, California 92626 USA

©2003 "QSC" and the QSC logo are registered with the U.S. Patent and Trademark Office.

## Free Manuals Download Website

<http://myh66.com>

<http://usermanuals.us>

<http://www.somanuals.com>

<http://www.4manuals.cc>

<http://www.manual-lib.com>

<http://www.404manual.com>

<http://www.luxmanual.com>

<http://aubethermostatmanual.com>

Golf course search by state

<http://golfingnear.com>

Email search by domain

<http://emailbydomain.com>

Auto manuals search

<http://auto.somanuals.com>

TV manuals search

<http://tv.somanuals.com>