



1675 MacArthur Blvd., Costa Mesa, CA, 92626 USA  
Main Number (714) 754-6175 Sales & Marketing (714) 957-7100 or toll free (USA only) (800) 854-4079  
Customer Service(714) 957-7150 or toll free (USA only) (800) 772-2834

# WideLine-8 Series Loudspeaker System User Manual

**WL3082**

full-range line array loudspeaker, black color (WL3082-WH for white color)

**WL212-sw**

subwoofer line array loudspeaker, black color (WL212-sw-WH for white color)

**AF3082-S**

small array frame for WideLine8, black color (AF3082-S-WH for white color)

**AF3082-L**

large array frame for WideLine8, black color (AF3082-L-WH for white color)

**PB3082**

pull-back bar, black (PB3082-WH for white color)

**EB3082**

extension bar, black (EB3082-WH for white color)

**CP3082**

cart and cover for WL3082 loudspeakers

**CP212**

cart and cover for WL212-sw loudspeakers

**AF8-10**

array frame adapter, WideLine-8 to Wideline, black (AF8-10-WH for white color)

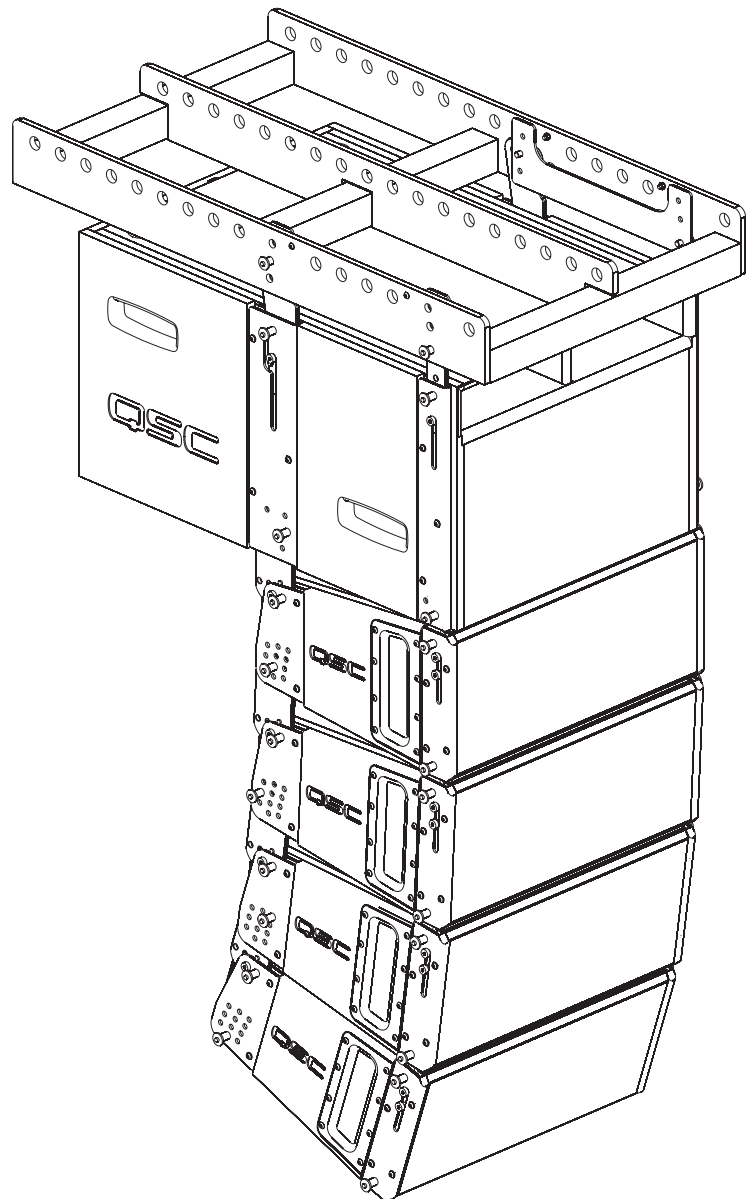

TD-000237-00 revA

## IMPORTANT SAFETY PRECAUTIONS

Install in accordance with QSC Audio Product's instructions and under the supervision of a licensed Professional Engineer.

### WARNING!

Before placing, installing, rigging, or suspending any speaker product, inspect all hardware, suspension, cabinets, transducers, brackets and associated equipment for damage. Any missing, corroded, deformed, or non-load rated component could significantly reduce the strength of the installation, placement or array. Any such condition severely reduces the safety of the installation and should be immediately corrected. Use only hardware which is rated for the loading conditions of the installation and any possible short-term, unexpected overloading. Never exceed the rating of the hardware or equipment.

Consult a licensed, Professional Engineer regarding physical equipment installation. Ensure that all local, state and national regulations regarding the safety and operation of suspended equipment are understood and adhered to.

### Warranty (USA only; other countries, see your dealer or distributor)

#### Disclaimer

QSC Audio Products, Inc. is not liable for any damage to amplifiers or any other equipment that is caused by negligence or improper installation and/or use of this loudspeaker product.

#### QSC Audio Products 3 Year Limited Warranty

QSC Audio Products, Inc. ("QSC") guarantees its products to be free from defective material and / or workmanship for a period of three (3) years from date of sale, and will replace defective parts and repair malfunctioning products under this warranty when the defect occurs under normal installation and use - provided the unit is returned to our factory or one of our authorized service stations via prepaid transportation with a copy of proof of purchase (i.e., sales receipt). This warranty provides that the examination of the return product must indicate, in our judgment, a manufacturing defect. This warranty does not extend to any product which has been subjected to misuse, neglect, accident, improper installation, or where the date code has been removed or defaced. QSC shall not be liable for incidental and/or consequential damages. This warranty gives you specific legal rights. This limited warranty is freely transferable during the term of the warranty period.

Customer may have additional rights, which vary from state to state.

In the event that this product was manufactured for export and sale outside of the United States or its territories, then this limited warranty shall not apply. Removal of the serial number on this product, or purchase of this product from an unauthorized dealer, will void this limited warranty.

Periodically, this warranty is updated. To obtain the most recent version of QSC's warranty statement, please visit [www.qscaudio.com](http://www.qscaudio.com).

Contact us at 800-854-4079 or visit our website at [www.qscaudio.com](http://www.qscaudio.com).

© Copyright 2007, QSC Audio Products, Inc.

QSC® is a registered trademark of QSC Audio Products, Inc.

Speakon® is a registered trademark of Neutrik® and the names of Neutrik® products referenced herein are either trademarks and/or service marks of Neutrik®.

All trademarks are the property of their respective owners.

"QSC" and the QSC logo are registered with the U.S. Patent and Trademark Office

## Introduction

The WideLine-8 is a high performance line array system designed for portable and installed sound reinforcement. The current WideLine-8 family is composed of the WL3082 line array element, WL212-sw subwoofer, AF3082-S small array frame, AF3082-L large array frame, PB3082 pull-back bar, EB3082 extension bar, and AF8-10 WideLine-8 to WideLine adapter frame. For further information on available suspension, transport, and signal processing options, please visit the QSC website: <http://www.qscaudio.com>

The WL3082 line array element uses two high-power, neodymium magnet, 2" voice-coil, 8" low-frequency drivers in a two-and-a-half way configuration. Both woofers produce low-frequencies but only one covers the mid-range, resulting in far better horizontal directivity control in the crossover region. Excellent high-frequency output and clarity are provided by a 3.0" voice coil, neodymium magnet compression driver with a titanium diaphragm. The compression driver is mounted to a patented multiple-aperture diffraction waveguide that provides an extremely wide horizontal coverage of 140°. As a result, systems will rarely require side or center fill speakers and solid stereo imaging is preserved across the listening area.

The low-frequency capability of a WL3082 array extends to 62 Hz (-10 dB); adequate for speech/vocal and acoustic music program material. For reinforcement of program material with more demanding low-frequency content, the WL212-sw companion subwoofer is available.

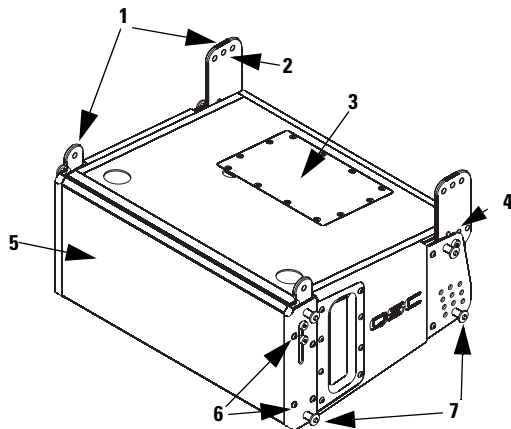

**Figure 1: WL3082 Loudspeaker**

**1- Suspension links**

**2- Suspension plate attachment holes**

**3- Driver access plate**

**4- Suspension alignment pin**

**5- Grille**

**6- Grille retaining screws (four total)**

**7- Ball-lock pins with lanyards**

**8- Recess for subwoofer feet**

**9- Landing skids**

**10- Input plate**

**11- Splay angle selection holes**

**12- Port/handle (patent pending)**

**13- Link slider knobs**

**14- Suspension attachment screws. Do not remove!**

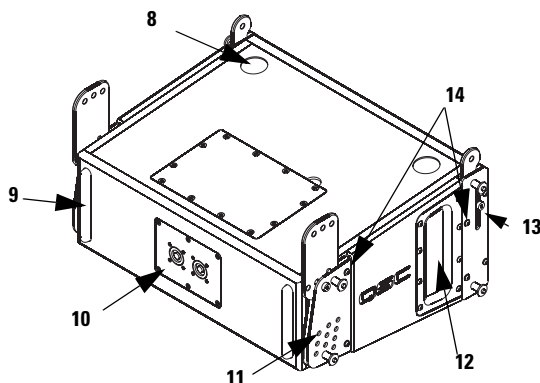

## Introduction (continued)

### WL212-sw

The WL212-sw subwoofer extends the system's low-frequency capability to 32 Hz with a compact fourth-order band-pass enclosure. Its two ceramic magnet, 4" voice coil, 12" transducers provide 1100 watt continuous power handling capability.

Many users of line array systems have found that suspending the subwoofers with the array provides audible benefit. Additionally, many venues lack physical space for floor-mounted subs. For these reasons, the WL212-sw includes suspension hardware and, with selection of the appropriate suspension accessories, subwoofers may be flown at the top of or behind a WL3082 array.

### Suspension

Suspending the WideLine-8 array is simple and flexible. Enclosures are built with integral suspension plates and are pinned together with ball-lock pins.

The AF3082-S and AF3082-L array frames support most suspended applications, and the EB3082 extension bar supports suspension where the center of gravity is beyond the limits of either frame. Additionally, the EB3082 is used for arrays where subwoofers are flown behind the main array. The PB3082 pull-back bar is used for pulling back the bottom element of the array for aiming and stability or as the primary suspension component for certain small arrays.

Ground stacking is easily accomplished directly on the subwoofer. The subwoofer has rubber feet to help keep the stack in place. Uptilt or downtilt of the groundstack is adjustable from -10° to +10°.

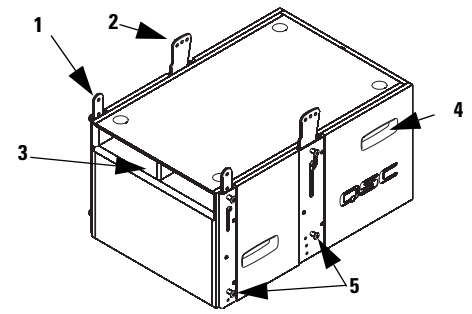

Figure 2: WL212-sw Subwoofer

1- Front suspension links

2- Rear suspension links

3- Port

4- Handles

5- Ball-lock pins with lanyards

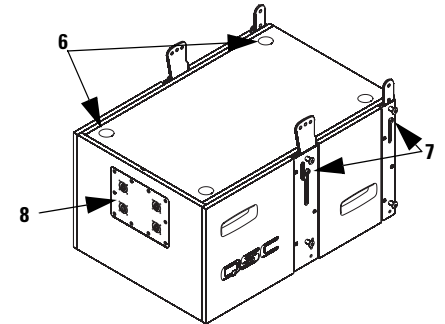

6- Recess for subwoofer feet

7- Link slider knobs

8- NL8 and NL4 Speakon input panel

9- Rubber feet

10- Driver access panel

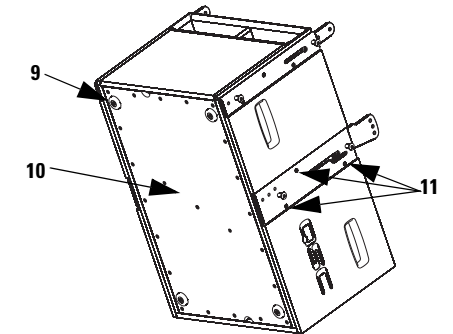

11- Mounting screws (Do Not Remove!)

Figure 3: AF3082-L Array Frame

1- Shackle holes (accept 5/8" (16mm) screw pin anchor shackle)

2- Center support bar

3- Suspension plates

4- Suspension plate attachment holes

5- Screws for lanyard attachment

6- Ball-lock pins with lanyards

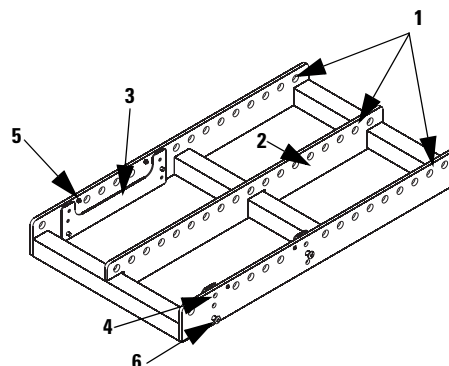

**Use only shackle holes for suspension of array!**

## **Introduction (continued)**



**Use only shackle holes for suspension of array!**

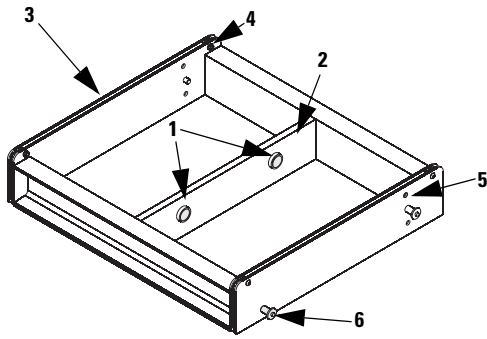

**Figure 4: AF3082-S Array Frame**

- 1- Shackle holes (accept 5/8" (16 mm) screw pin anchor shackle)**
- 2- Center support bar**
- 3- Suspension plates**
- 4- Lanyard retaining screw for ball-lock pin lanyard**
- 5- Suspension plate attachment holes**
- 6- Ball-lock pins with lanyards**

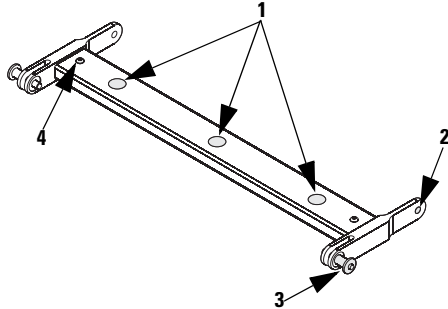

**Figure 5: PB3082 Pull Back Bar**

- 1- Shackle hole (accepts 5/8" (16 mm) screw pin anchor shackle)**
- 2- Suspension plate attachment holes**
- 3- Ball-lock pins with lanyards**
- 4- Lanyard retaining screw for ball-lock pin lanyard**

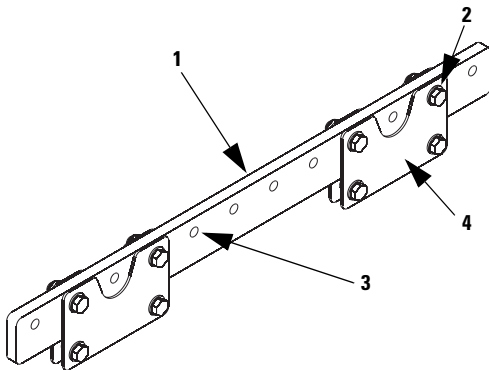

**Figure 6: EB3082 Extension Bar**

- 1- Extension bar**
- 2- Suspension plate retaining bolts**
- 3- Shackle holes (accept 5/8" (16 mm) screw pin anchor shackle)**
- 4- Suspension plates**

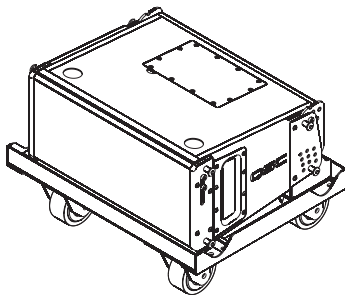

**Figure 7: CP3082 Cart**

Accommodates up to 4 WL3082 enclosures and includes a padded soft cover.

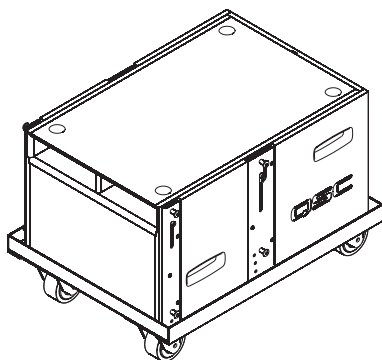

**Figure 8: CP212 Cart**

Accommodates up to 3 WL212-sw enclosures and includes a padded soft cover.

## **Introduction (continued)**

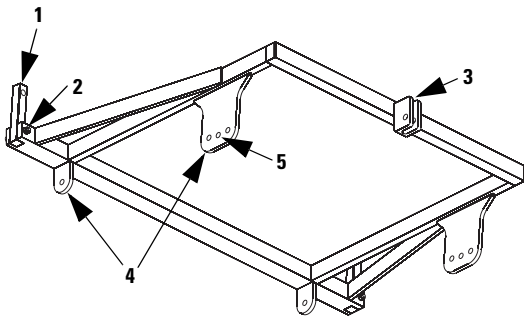

**Figure 9: AF8-10 WideLine-8 to WideLine Adapter Frame**

- 1- WideLine attachment knuckles**
- 2- Knuckle retaining bolt**
- 3- Rear link receiver for WideLine loudspeaker**
- 4- WideLine-8 attachment links**
- 5- Suspension plate attachment holes**

## **Suspending the WideLine-8 Array**

### **Rules for Suspension**

- Correct use of all suspension hardware and components is imperative in sound system suspension and deployment.
- Always calculate suspended loads before lifting to ensure suspension components and hardware are used within their respective load limits.
- Research local codes and regulations to fully understand the requirements for suspended loads in the venue in which the equipment is to be suspended.
- Use only shackle holes for suspension of array.
- Be absolutely certain of the integrity of any structural member intended to support suspended loads. Hidden structural members can have hidden structural weakness.
- Consult a Professional Mechanical or Structural Engineer licensed in the jurisdiction of the sound system installation to review, verify, and approve all attachments to the building or structure.
- Never assume anything- Owner or third-party supplied suspension attachment points may not be adequate for the loads to be suspended.
- Employ the services of a Professional Rigger for hoisting, positioning, and attaching the equipment to the supporting structure.
- Always inspect all components (enclosures, suspension brackets, pins, frames, bolts, nuts, slings, shackles, etc.) for cracks, wear, deformation, corrosion, missing, loose, or damaged parts that could reduce the strength of the assembly before lifting. Discard any worn, defective, or suspect parts and replace them with new appropriately load-rated parts.

### **Shock Loading**

When a load is either moved or stopped, its static weight is magnified. Sudden movements can magnify the static weight several times. This magnification of static weight is termed "shock loading". Shock loading poses a danger to equipment and workers. The effects of shock loading can be instantaneous, or they may remain undetected unless the equipment is visually damaged. Avoiding shock loading requires careful planning and knowledge of equipment, suspension, and lifting practices.

Shock loading of equipment and structures is usually confined to lifting and installation, but natural forces (winds, earthquakes) can impose shock loads several times the static load. This is why structures and suspension equipment must be capable of supporting several times the weight of the equipment suspended.

### **WideLine-8 Working Load Limits and Design Factors**

Table 1 lists the WideLine-8 suspension components and provides Working Load Limit data at various Design Factors. The tabulated Design Factors are for static loads only. The choice of which Design Factor to use will depend upon the jurisdiction and venue of installation, as well as the conditions of suspension. Dynamic conditions are determined by unknown, installation-specific factors and should be referred to a Licensed Structural Engineer for clarification before proceeding with any suspension of the equipment. The data presented is based upon the listed component weights:

# Suspending the WideLine-8 Array

**Table 1: WideLine-8 Working Load Limits<sup>1</sup>**

Component	Weight	7:1 Design Factor	10:1 Design Factor	12:1 Design Factor
EB3082 Extension Bar	27 lb (12.3 kg)	1751 lb (714.3 kg)	1100 lb (500.0 kg)	917 lb (416.7 kg)
AF3082-S Array Frame	11 lb (5.0 kg)	746 lb (339.0 kg)	522 lb (237.3 kg)	435 lb (197.7 kg)
AF3082-L Array Frame	27 lb (12.3 kg)	1274 lb (579.2 kg)	892 lb (405.5 kg)	743 lb (337.9 kg)
PB3082 Pull Back Bar	3 lb (1.4 kg)	434 lb (197.4 kg)	304 lb (138.2 kg)	253 lb (115.2 kg)
WL3082 Loudspeaker	38 lb (17.3 kg)	651 lb (296.1 kg)	456 lb (207.3 kg)	380 lb (172.7 kg)
WL212-sw Loudspeaker	109 lb (49.5 kg)	1274 lb (579.2 kg)	892 lb (405.5 kg)	743 lb (337.9 kg)
AF8-10 Adapter Frame	9 lb (4.1 kg)	326 lb (148.1 kg)	228 lb (103.6 kg)	190 lb (86.4 kg)
M8 Ball Lock Pin <sup>2</sup>	n/a	1810 lb (822.7 kg)	1267 lb (575.9 kg)	1056 lb (479.9 kg)
M8 Shoulder Screw <sup>2</sup>	n/a	1847 lb (839.4 kg)	1293 lb (587.6 kg)	1077 lb (489.6 kg)
3/4" Fastener <sup>2</sup>	n/a	5693 lb (2587.8 kg)	3985 lb (1811.4 kg)	3321 lb (1509.5 kg)

1- Data available on QSC Audio's website. Please visit <http://www.qscaudio.com>

2- Working Load Limits are per fastener loaded in double shear. Data is for informational purposes only.

## Attaching WL3082 to Array Frame

Before beginning any installation, have your system designer configure the array with proper splay angles using QSC's EASE Focus (Array Calculator). All orientation of product is to be viewed from the rear of the enclosure.

1. Attach the array frame to the suspension structure using a 5/8" (16mm) screw pin anchor shackle and appropriate sling, cable, etc.
2. For arrays of 4 WL3082 or less, pin together the cluster of enclosures or prepare pre-pinned array from transport cart. Note the QSC logo on the input plate will be right side up when the enclosure is oriented properly. During assembly, ensure your splay angles are set as desired.
3. Attach the array frame to the top enclosure by inserting the ball-lock pins in the appropriate locations. Ensure selection of the desired splay angle on the rear link (0°, +5°, -5°).



**NOTE:** For some array configurations, use of the extension bar and/or pull-back may be required to achieve the required aiming angle.

**When constructing large arrays it is recommended to first assemble units of four enclosures and then assemble the final array by joining the four enclosure units to one another.**

**If extreme uptilt is required, turn the AF3082-L around (rotate 180°) and attach the WL3082 enclosures toward the rear of the frame; this will allow suspending at a more extreme upward angle. Note: The markings on the array frame are no longer valid once the frame is turned around (their positions are reversed).**

**Figure 10: WL3082 attached to AF3082-S**

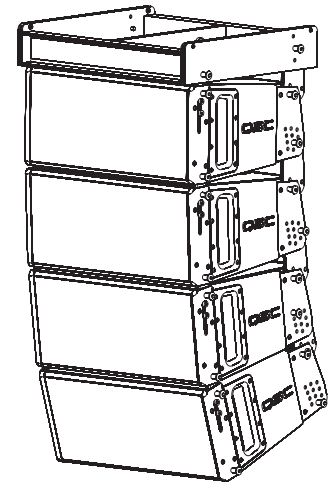

**Figure 11: WL3082 attached to AF3082-L**

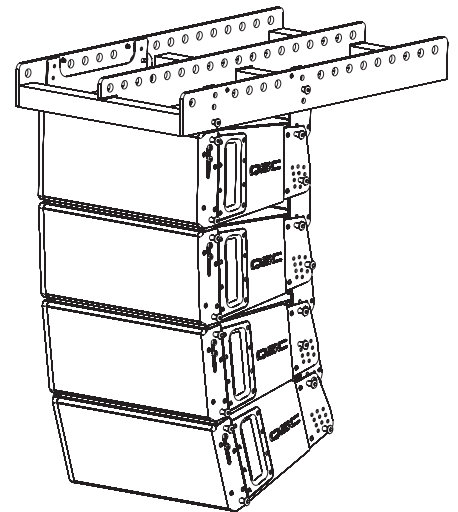

**Figure 12: Detail of WL3082 attached to AF3082-L**

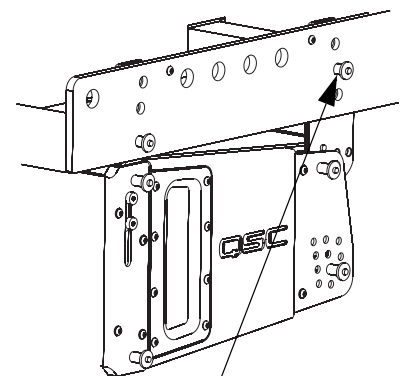

**Pin rear in center position for 0° tilt. Upper and lower holes are for -5° and +5°, respectively.**

## Suspending the WideLine-8 Array

### Suspending the WL212-sw beneath AF3082-S or AF3082-L

All orientation of product is to be viewed from the rear of the enclosure. The QSC logo on the input plate will appear right side up when the enclosure is oriented properly.

1. Lower the array frame onto the subwoofer and align the appropriate holes in the suspension links and frame, fully insert the ball-lock pins, and ensure all pins lock properly. On the array frame, use the center hole to attach the sub's rear link (labeled 0°).
2. Attach the AF3082-S or AF3082-L array frame to the suspension structure using 5/8" (16mm) screw-pin anchor shackle and appropriate sling, cable, etc.



**Note! The +5° and -5° positions can not be used when suspending the subwoofer from the array frame.**

3. Before lifting, ensure the audio connection to the enclosures are correct and functioning.



**NOTE: When arraying two or more WL212-sw subwoofers with one person, it is easiest to lay the enclosures on their backs, align and mate the suspension straps, and install the ball-lock pins. When installing the ball-lock pins, ensure full insertion and locking action.**

Figure 15: WL212-sw attached to AF3082-S.

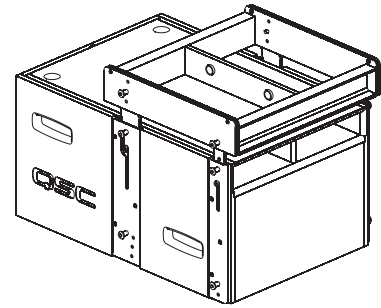
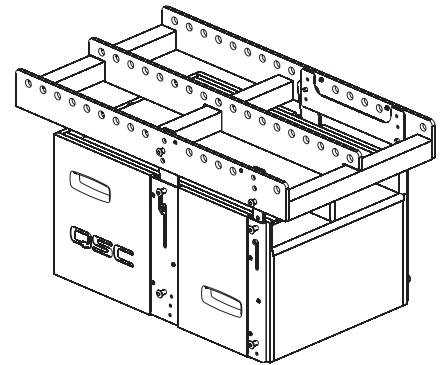

Figure 16: WL212-sw suspended beneath AF3082-L



### Suspending WL3082 enclosures beneath WL212-sw enclosures

1. For arrays of 4 WL3082 or less, pin together the cluster of enclosures or prepare pre-pinned array from transport cart. When constructing large arrays it is recommended to first assemble units of four enclosures and then assemble the final array by joining the four enclosure units to one another. Note the QSC logo on the input plate will be right side up when the enclosure is oriented properly). During assembly, ensure your splay angles are set as desired.
2. Lower the array frame with subwoofer(s) onto the WL3082 enclosure cluster, carefully aligning the appropriate holes in the suspension plates and links. Attach the top enclosure to subwoofer by inserting the ball-lock pins, and ensuring all pins lock properly. Ensure selection of the desired splay angle on the rear links (0°, +5°, -5°).
3. Before lifting, ensure the audio connection to the enclosures are correct and functioning.

Figure 17: WL3082 enclosures suspended below WL212-sw with AF3082-S array frame.

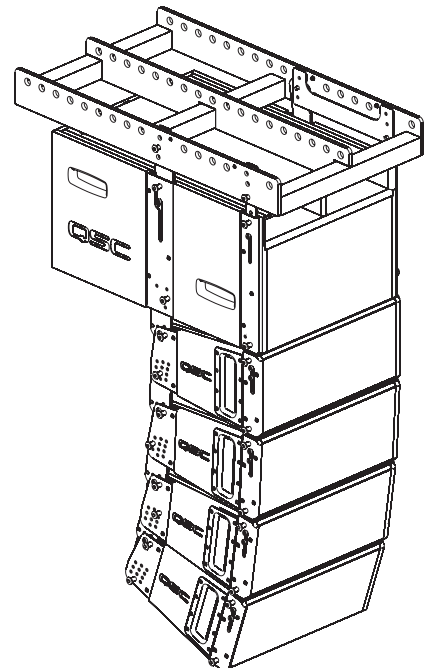



## **Suspending the WideLine-8 Array**

### **Pull-Back Bar**

To use the pull-back bar, attach it to the bottom enclosure's suspension plates using one of the lower sets of splay angle adjustment holes. Align the pull-back bar's holes with the suspension plate's and fully insert the ball-lock pins. Ensure locking action of pins. Use a 5/8" (16 mm) screw-pin anchor shackle to attach to the pull-back bar as required using the shackle holes.



**NOTE: All hardware/components must be rated for the expected loads as determined by the Professional Engineer responsible for suspension.**

**NOTE: The PB3082 can also be used to suspend small arrays of WL3082 enclosures. See page 10 for detailed information.**

### **Extension Bar**

The extension bar suspension plates can be moved, if required, by removing the two 3/4" mounting bolts, moving to the selected mounting location, and reattaching. Tightening torque is to be 100 lb-ft of torque (135.6 N-m) Ease-Focus software's center-of-gravity calculator will provide a suitable point for desired down-tilt.

Attach the array frame to the extension bar suspension plates by centering the array frame member between the extension bar suspension plates and bolting together using the supplied 3/4" bolts.

**Figure 13: PB3082 under WL3082 attached to AF3082-S.**

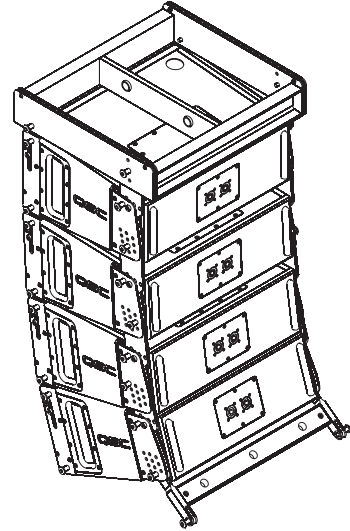

**Figure 14: Use of EB3082 Extension Bar.**

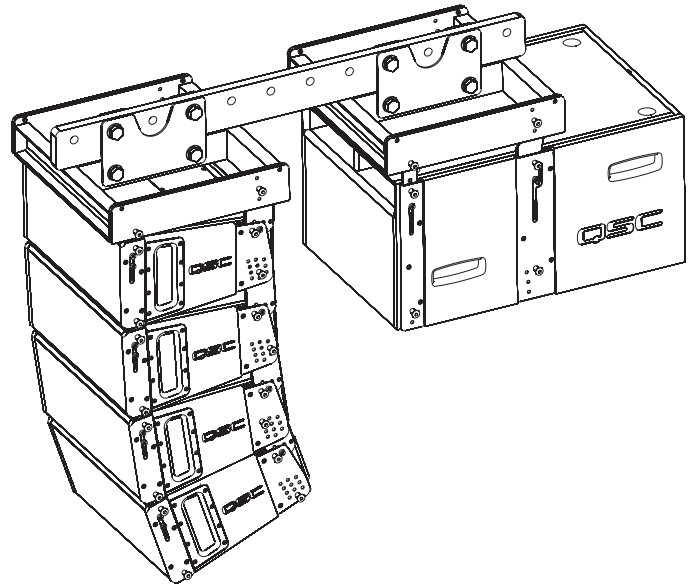

## Suspending the WideLine-8 Array

### Attaching WL212-sw behind WL3082 array using EB3082 and two AF3082-S array frames

1- Attach both AF3082-S array frames to the extension bar suspension plates by centering the array frame member between the extension bar suspension plates and bolting together using the supplied 3/4" bolts. The extension bar suspension plates can be moved, if required, by removing the two 3/4" mounting bolts, moving to the selected mounting location, and reattaching. Tightening torque is to be 100 lb-ft (135.6 N-m). Ease-Focus software's center-of-gravity calculator will provide a suitable point (or two points) for desired down-tilt.

2- Attach WL212-sw subwoofer(s) to the rear array frame

3- Attach WL3082 loudspeaker(s) to the front array frame.



**NOTE: When stacking loudspeakers for attachment to array frames using the extension bar, we recommend working with groups of 2 WL3082 for each WL212-sw. Start with no splay angle; this yields the same height for landing the extension bar. Adjust splay angle once the system is lifted.**

### Suspending 8 or less WL3082 Loudspeakers Using Two Pull-Back Bars



**NOTE: Do not suspend more than 8 WL3082 loudspeakers from a PB3082 pull-back bar! Do not use PB3082 pull-back bar for suspending anything other than 8 or less WL3082 loudspeakers! Do not suspend the WL212-sw from the PB3082 pull-back bar!**

1- For arrays of 4 WL3082 or less, pin together the cluster of enclosures or prepare pre-pinned array from transport cart. If constructing larger arrays we recommend to first assemble units of four enclosures and then assemble the final array by joining the four enclosure units to one another. Note the QSC logo on the input plate will be right side up when the enclosure is oriented properly. During assembly, ensure your splay angles are set as desired.

2- Pin one PB3082 to the top WL3082's front suspension plate attachment holes. Ensure locking action of pins.

3- Attach a 5/8" (16 mm) screw-pin anchor shackle to the pull-back bar's center shackle hole for lifting.

4- Pin a second PB3082 to the bottom WL3082's rear suspension plate. Ensure locking action of pins. Use a 5/8" (16 mm) screw-pin anchor shackle attached through a shackle hole for pulling back.

Figure 18: EB3082 with WL212-sw suspended at rear and WL3082 array suspended at front.

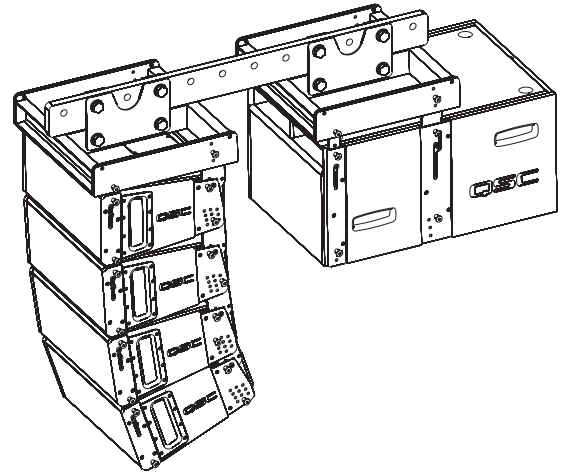
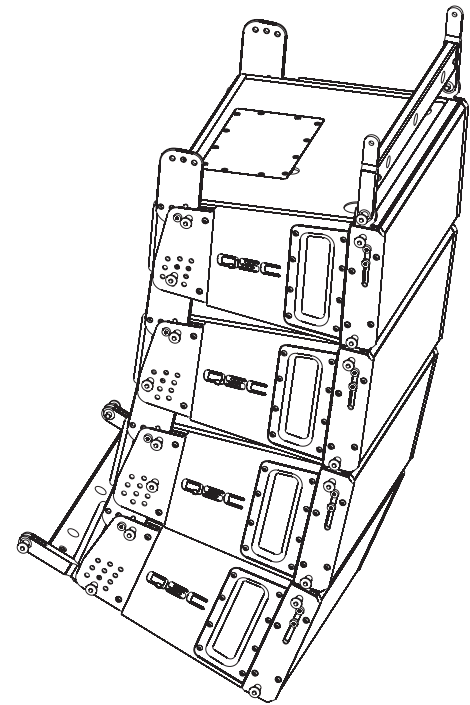

Figure 19: Using two PB3082 Pull Back Bars for suspending a maximum of 8 WL3082 loudspeakers.



**Warning! Eight (8) WL3082 loudspeakers is the maximum allowable load (10:1 design factor) for the PB3082. Do not suspend more than eight WL3082 loudspeakers from the PB3082.**

## Ground Stack Configurations

The WL212-sw enclosure is fitted with rubber feet on the bottom making the enclosure itself suitable for ground stack applications. Matching recesses in the enclosure's top surface facilitate secure stacking of one WL212-sw atop another.

The design of the suspension links accommodates uptilt and downtilt when attaching WL3082 enclosures to the WL212-sw. Adjustment range is from  $-10^{\circ}$  to  $+10^{\circ}$ .

Figure 20:  $0^{\circ}$  tilt WL3082 on WL212-sw

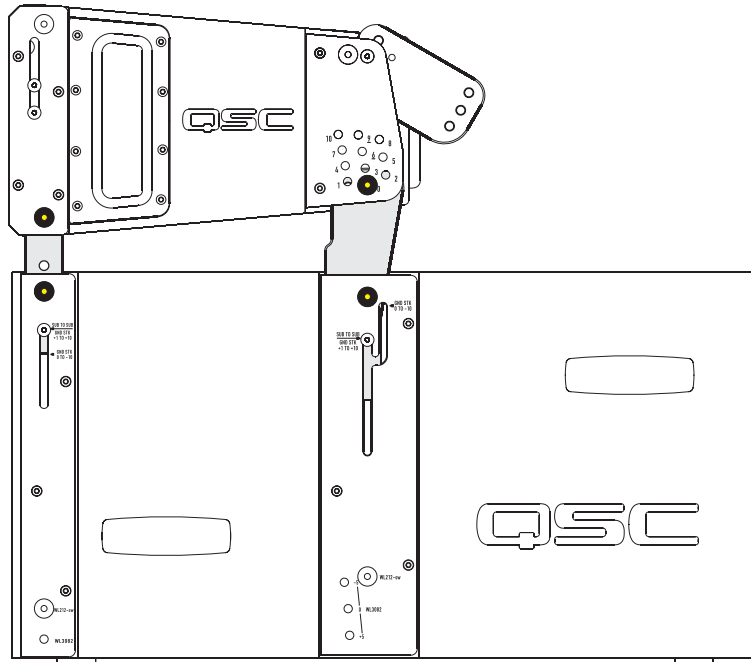
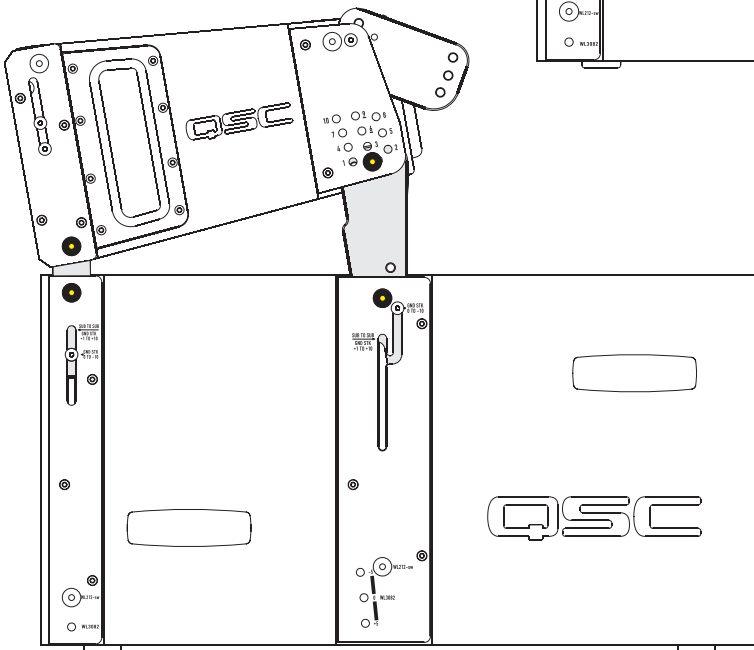

Figure 21:  $-10^{\circ}$  tilt WL3082 on WL212-sw



**NOTE:** Link sliders and pin locations determine splay angle between enclosures.

**NOTE:** When groundstacking multiple WL212-sw enclosures, ensure suspension is secure prior to attaching array.

Figure 22:  $+10^{\circ}$  tilt WL3082 on WL212-sw

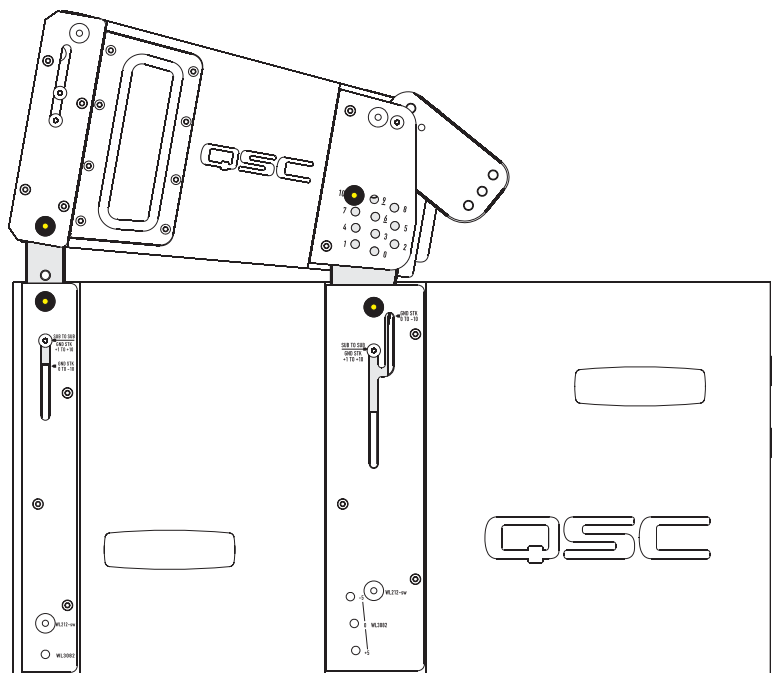

## WL3082 Connections

The WL3082 input connectors are a pair of Neutrik NL8's wired in parallel. See Table 2 or the pinout on the WL3082 input plate (on rear of enclosure).



**The WL3082 loudspeaker is not equipped with a crossover network. All signal processing must be done before connecting audio power to the loudspeaker. Do not connect full-range audio to the high-frequency transducer or damage may result!**

**Table 2: WL3082 Connector Pinout**

PIN	Connection
1+	Through
1-	Through
2+	Right low frequency transducer + (16 Ohms)
2-	Right low frequency transducer - (16 Ohms)
3+	Left low frequency transducer + (16 Ohms)
3-	Left low frequency transducer - (16 Ohms)
4+	High frequency transducer + (16 Ohms)
4-	High frequency transducer - (16 Ohms)

## WL212-sw Connections

### Input Connections

The WL212-sw is equipped with two NL8 connectors with pins 1+ and 1- connected to the transducers. All other NL8 connections are paralleled between the two NL8s. Additionally, pins 1+ and 1- are parallel connected to the NL4s.

The WL212-sw is also equipped with two NL4 connectors that have pins 1+ and 1- connected to the transducers. Pins 2+ and 2- of the NL4s are parallel connected. Only pins 1+ and 1- of the NL4s are paralleled with the NL8s 1+ and 1- pins.

Please refer to Tables 2 and 3 for pinouts. The pinouts are printed on the input plate label, as well.



**Note: pin numbers 1+ and 1- of all connectors are wired in parallel. Pins 1+ and 1- are the only parallel interconnect between the NL4 and the NL8 connectors. All remaining connections of the NL4 and NL8 connectors are independent.**

**Table 3: WL212-sw NL8 Connector Pinout**

PIN	Connection
1+	Low frequency transducers + (4 Ohms) Also connected to NL4 Pin 1+
1-	Low frequency transducers - (4 Ohms) Also connected to NL4 pin 1-
2+	LF
2-	LF
3+	MID
3-	MID
4+	HF
4-	HF

**Table 4: WL212-sw NL4 Pinout**

Pin	Connection
1+	Low frequency transducers + (4 ohms) Also connected to NL8 pin 1+
1-	Low frequency transducers - (4 ohms), also connected to NL8 pin 1-
2+	Through
2-	Through

## WL3082 Specifications

Frequency Response:	68 - 18,000 Hz (+/- 3 dB)	
Frequency Range:	62 - 20,000 Hz (-10 dB)	
Maximum SPL (continuous/peak):	HF: 127/133 dB	LF: 122/128 dB
Nominal Coverage (-6 dB included):	Horizontal: 140 degrees (500 Hz to 3.2 kHz) Vertical: dependant on cumulative splay angles	
Transducers:		
High Frequency:	Single 85W, 16 Ohm, 1.4 inch exit, 3 inch composite polyimide diaphragm, neodymium magnet	
Low Frequency:	Dual 250W, 16 Ohm 8 inch cone transducer, 2 inch voice coil, neodymium magnet, weather resistant cone	
Acoustic Crossover Frequency:	High to Mid: 1250 Hz	Mid to Low: 300 Hz
Input Sensitivity:	HF: 108 dB	
	LF: 98 dB	
Weight:	Net: 38 lb (17.3 kg)	Shipping: 45.5 lb (20.6 kg)
Enclosure:	15mm Baltic birch plywood (baffle is 18mm Baltic birch plywood)	
Grille:	Steel (16 gauge) with cloth	
Connectors:	Two (2) Neutrik NL8 in parallel (wired as shown in Table 2)	
Working Load Limit Information:		

Component	Weight	7:1 Design Factor	10:1 Design Factor	12:1 Design Factor
WL3082 Loudspeaker	38 lb (17.3 kg)	651 lb (296.1 kg)	456 lb (207.3 kg)	380 lb (172.7 kg)

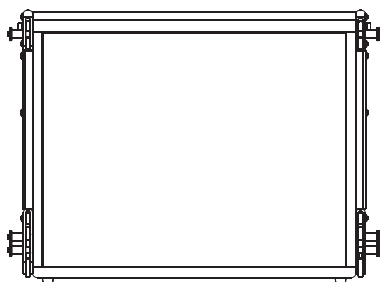
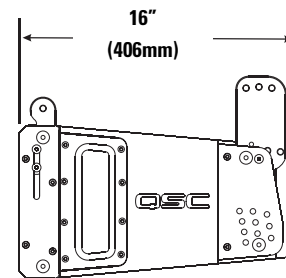
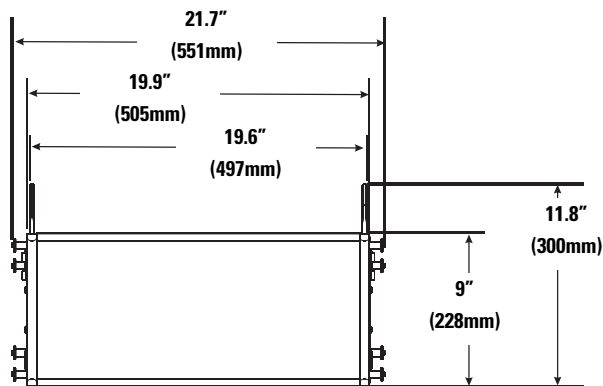

## WL212-sw Specifications

Frequency Response:	40 - 100 Hz (+/- 3 dB)		
Frequency Range:	32 - 107 Hz (-10 dB)		
Maximum SPL (continuous/peak):	129 dB/135 dB		
Transducer:	1100W, dual 12 inch woofer, 4 inch voice coil, ceramic magnet assembly		
Recommended Crossover Frequency:	30 - 85 Hz		
Input Sensitivity:	99 dB		
Weight:	Net: 109 lb (49.4 kg)	Shipping: 125 lb (56.7 kg)	
Enclosure:	0.708 inch (18 mm) Baltic birch plywood, paint finish.		
Connectors:	Two (2) Neutrik NL4 and two Neutrik NL8 all wired in parallel (wired as shown in Table 3)		
Working Load Limit Information:			

Component	Weight	7:1 Design Factor	10:1 Design Factor	12:1 Design Factor
WL212-sw Loudspeaker	109 lb (49.5 kg)	1274 lb (579.2 kg)	892 lb (405.5 kg)	743 lb (337.9 kg)

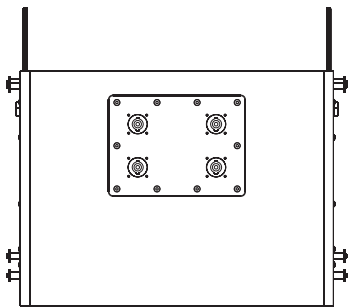
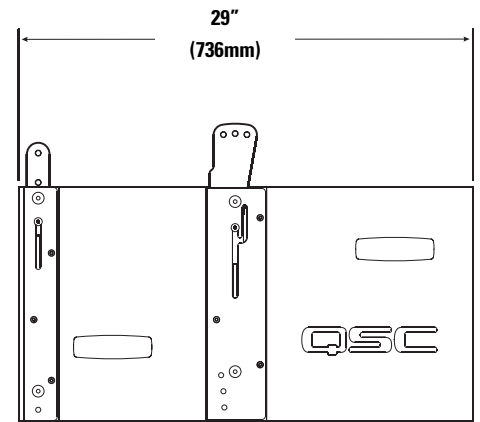
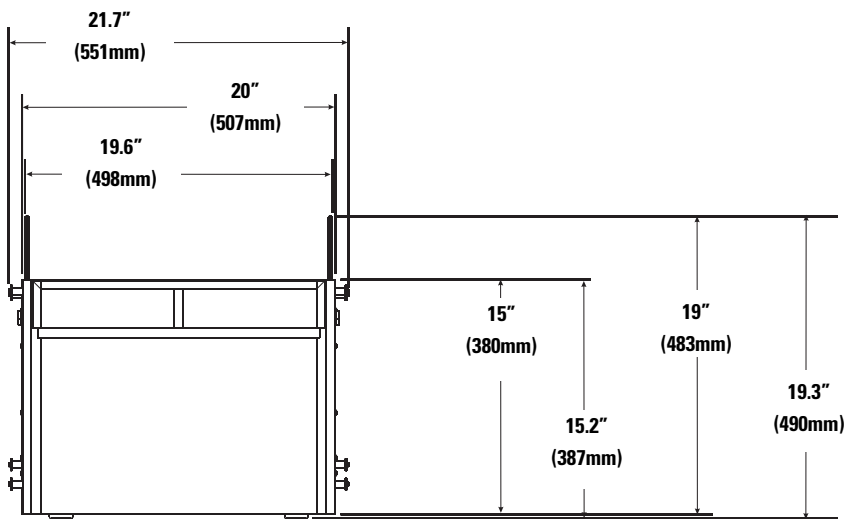

## EB3082 Specifications

Material: Aluminum 6061-T6  
 Finish: Black powder coat (White optional)  
 Working Load Limit Information:

Component	Weight	7:1 Design Factor	10:1 Design Factor	12:1 Design Factor
EB3082 Extension Bar	27 lb (12.3 kg)	1751 lb (714.3 kg)	1100 lb (500.0 kg)	917 lb (416.7 kg)

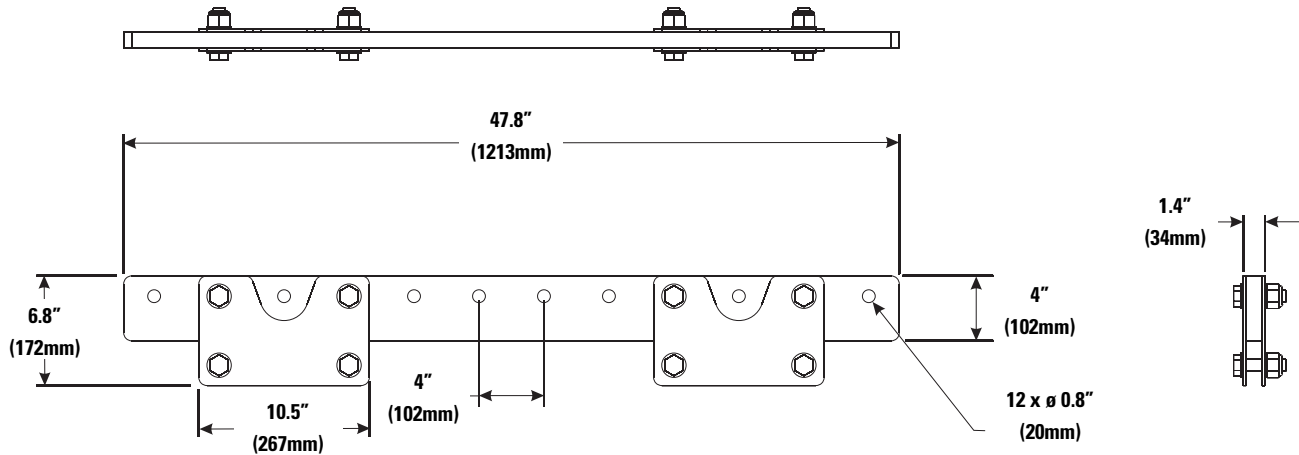

## AF3082-S Specifications

Material: Aluminum 6061-T6  
 Finish: Black powder coat (White optional)  
 Working Load Limit Information:

Component	Weight	7:1 Design Factor	10:1 Design Factor	12:1 Design Factor
AF3082-S Array Frame	11 lb (5.0 kg)	746 lb (339.0 kg)	522 lb (237.3 kg)	435 lb (197.7 kg)

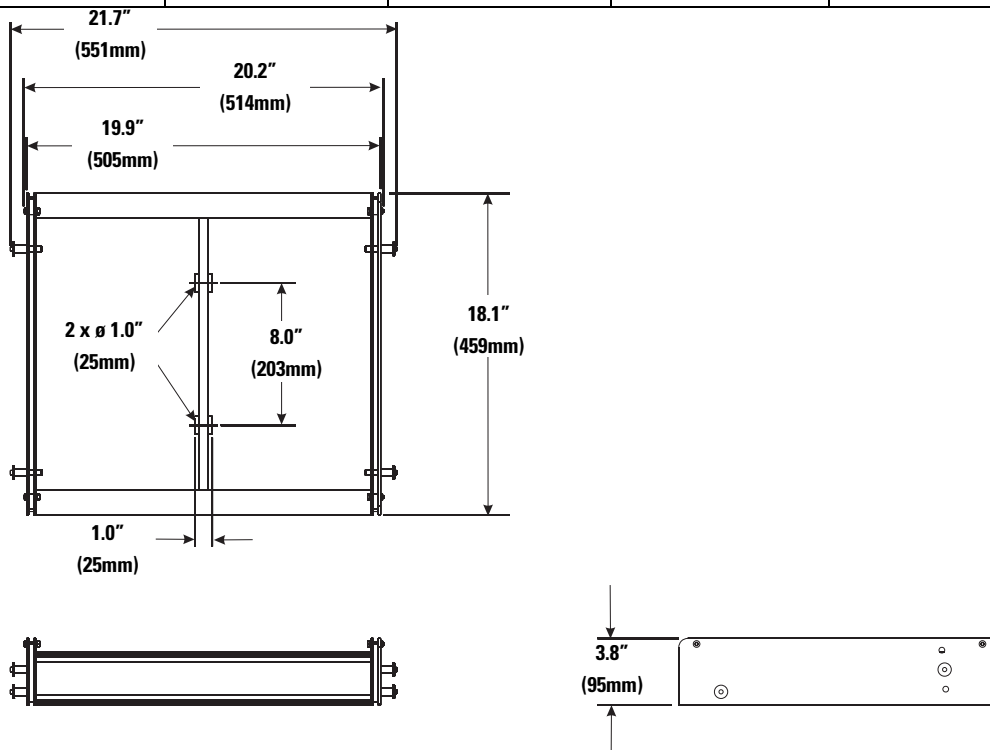

# AF3082-L Specifications

Material: Aluminum 6061-T6  
 Finish: Black powder coat (White optional)  
 Working Load Limit Information:

Component	Weight	7:1 Design Factor	10:1 Design Factor	12:1 Design Factor
AF3082-L Array Frame	27 lb (12.3 kg)	1274 lb (579.2 kg)	892 lb (405.5 kg)	743 lb (337.9 kg)

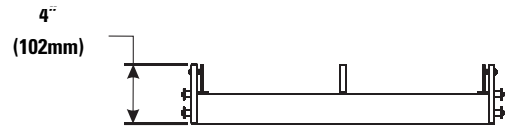
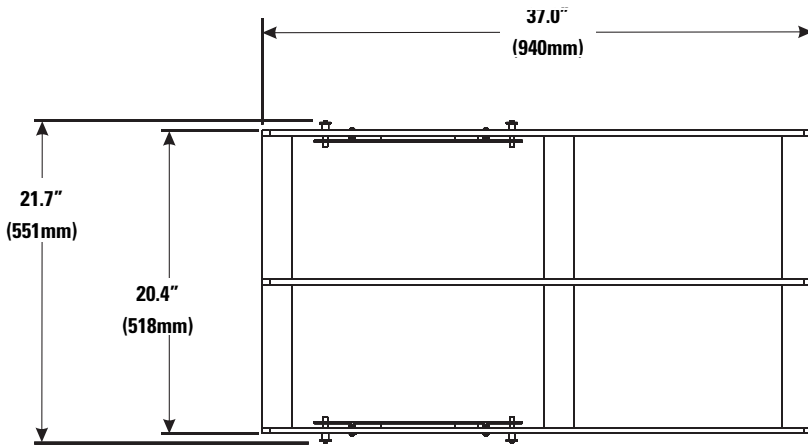



## PB3082 Specifications

Material Aluminum 6061-T6  
 Finish Black powder coat (White optional)

Working Load Limit Information:

Component	Weight	7:1 Design Factor	10:1 Design Factor	12:1 Design Factor
PB3082 Pull Back Bar	3 lb (1.4 kg)	434 lb (197.4 kg)	304 lb (138.2 kg)	253 lb (115.2 kg)

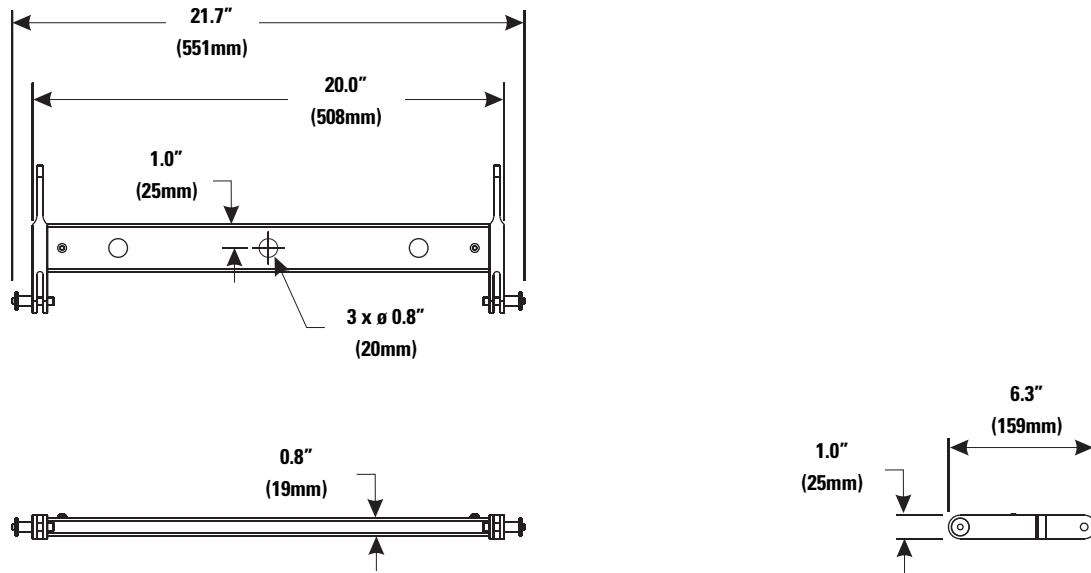

## AF8-10 Specifications

Material Aluminum 6061-T6  
 Finish Black powder coat (White optional)

Working Load Limit Information:

Component	Weight	7:1 Design Factor	10:1 Design Factor	12:1 Design Factor
AF8-10 Adapter Frame	9 lb (4.1 kg)	326 lb (148.1 kg)	228 lb (103.6 kg)	190 lb (86.4 kg)

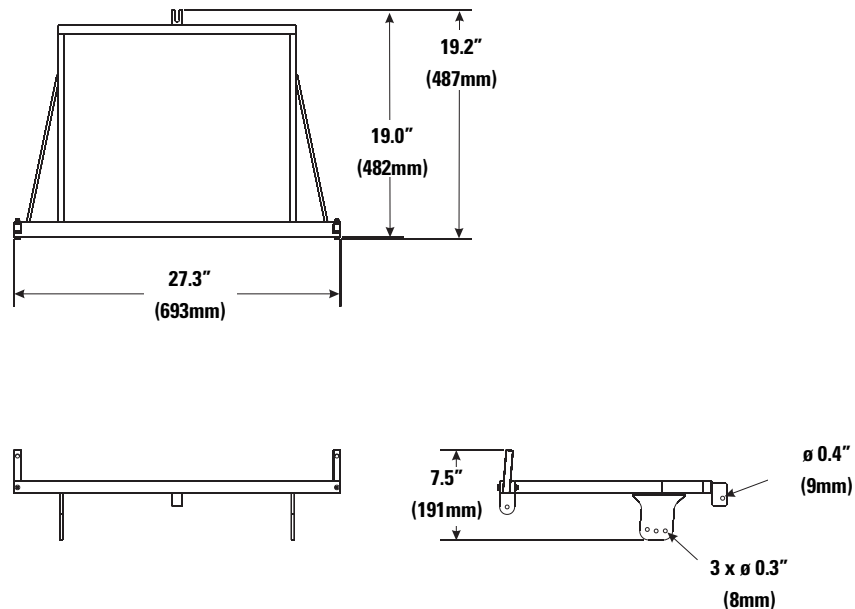

This page was left blank intentionally.

This page was left blank intentionally.

## **How to Contact QSC Audio Products**

### **Mailing address:**

QSC Audio Products, Inc.  
1675 MacArthur Boulevard  
Costa Mesa, CA 92626-1468 USA

### **Telephone Numbers:**

Main Number	(714) 754-6175
Sales & Marketing	(714) 957-7100 or toll free (USA only) (800) 854-4079
Customer Service	(714) 957-7150 or toll free (USA only) (800) 772-2834

### **Facsimile Numbers:**

Sales & Marketing FAX	(714) 754-6174
Customer Service FAX	(714) 754-6173

### **World Wide Web:**

[www.qscaudio.com](http://www.qscaudio.com)

### **E-mail:**

[info@qscaudio.com](mailto:info@qscaudio.com)  
[service@qscaudio.com](mailto:service@qscaudio.com)



QSC Audio Products, Inc. 1675 MacArthur Boulevard Costa Mesa, California 92626 USA  
©2007 "QSC" and the QSC logo are registered with the U.S. Patent and Trademark Office.

## Free Manuals Download Website

<http://myh66.com>

<http://usermanuals.us>

<http://www.somanuals.com>

<http://www.4manuals.cc>

<http://www.manual-lib.com>

<http://www.404manual.com>

<http://www.luxmanual.com>

<http://aubethermostatmanual.com>

Golf course search by state

<http://golfingnear.com>

Email search by domain

<http://emailbydomain.com>

Auto manuals search

<http://auto.somanuals.com>

TV manuals search

<http://tv.somanuals.com>