

CMX Series

User Manual



CMX 300V

CMX 500V

CMX 800V

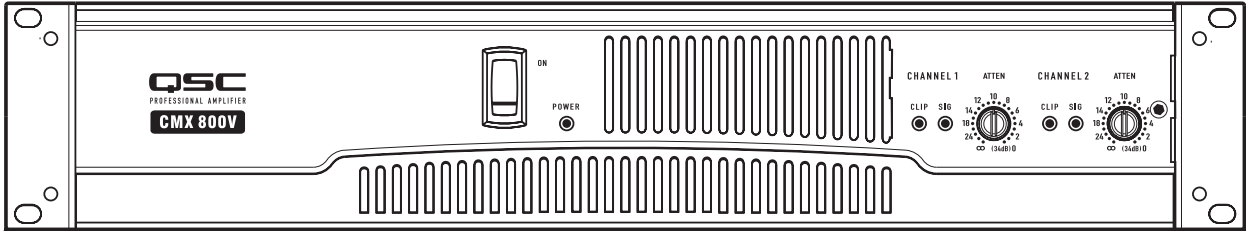
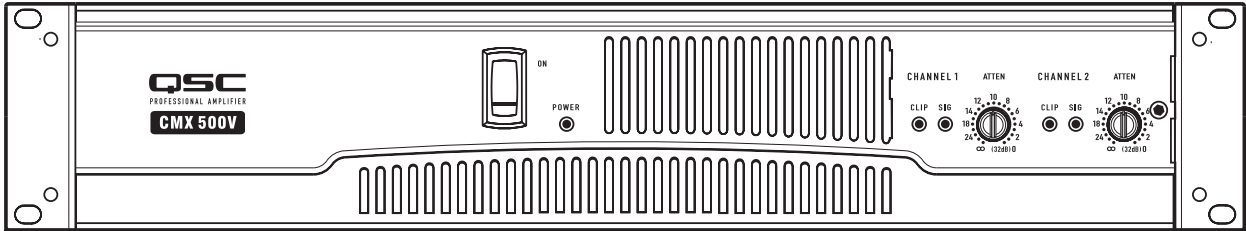
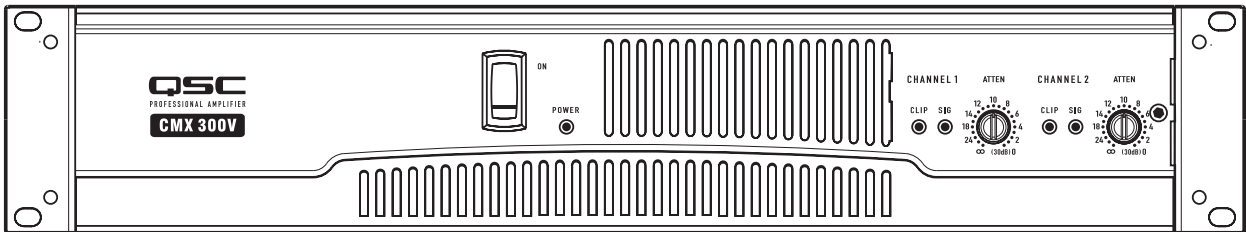

TD-000322-00-B



IMPORTANT SAFETY PRECAUTIONS AND EXPLANATION OF SYMBOLS



The lightning flash with the arrowhead symbol within an equilateral triangle is intended to alert the user to the presence of uninsulated "dangerous" voltage within the product's enclosure that may be of sufficient magnitude to constitute a risk of shock to humans.



The exclamation point within an equilateral triangle is intended to alert the user to the presence of important operation and maintenance (servicing) instructions in this manual.

1. Read these instructions.
2. Keep these instructions.
3. Heed all warnings.
4. Follow all instructions.



WARNING: To prevent fire or electric shock, do not expose this equipment to rain or moisture. Do not use this apparatus near water.

5. Clean only with a dry cloth.
6. Allow a minimum of 6" (152 mm) clearance behind cabinet for convection cooling. Keep anything that might restrict airflow from the rear of the enclosure (i.e. draperies, fabric, etc.). Do not block any ventilation opening. This product is a power amplifier that produces heat.
7. Do not install near any heat sources such as radiators, heat registers, stoves, or other apparatus (including amplifiers) that produce heat.
8. Do not defeat the safety purpose of the grounding-type plug on the three-pronged "Edison" style power cable. The grounding plug has two blades and a grounding prong. The third prong is provided for your safety. If the provided plug does not fit your outlet, consult an electrician for the replacement of the obsolete outlet. Do not cut off the grounding plug or use an adapter that breaks the grounding circuit. This apparatus must be properly grounded for your safety.
9. Protect the power cord from being walked on or pinched, particularly plugs, convenience receptacles, and the point where they exit from the apparatus.
10. The appliance coupler is the AC mains disconnect and should remain readily operable after installation.
11. Use only attachments/accessories specified by QSC Audio Products, LLC.
12. Use only with hardware, brackets, and components sold with the apparatus or by QSC Audio Products, LLC.
13. Unplug the apparatus during lightning storms or when unused for long periods of time.
14. Refer all servicing to qualified service personnel. Servicing is required when the apparatus has been damaged in any way, such as power supply cord or plug is damaged, liquid has been spilled or objects have fallen into the apparatus, the apparatus has been exposed to rain or moisture, does not operate normally or has been dropped.
15. The appliance shall not be exposed to dripping or splashing and no objects filled with liquids, such as vases, shall be placed on the apparatus.

Warranty (USA only; other countries, see your dealer or distributor)

Disclaimer

QSC Audio Products, LLC is not liable for any damage to amplifiers, or any other equipment that is caused by negligence or improper installation and/or use of this loudspeaker product.

QSC Audio Products 6-Year Limited Warranty

QSC Audio Products, LLC ("QSC") guarantees its products to be free from defective material and / or workmanship for a period of six (6) years from date of sale, and will replace defective parts and repair malfunctioning products under this warranty when the defect occurs under normal installation and use - provided the unit is returned to our factory or one of our authorized service stations via prepaid transportation with a copy of proof of purchase (i.e., sales receipt). This warranty provides that the examination of the return product must indicate, in our judgment, a manufacturing defect. This warranty does not extend to any product which has been subjected to misuse, neglect, accident, improper installation, or where the date code has been removed or defaced. QSC shall not be liable for incidental and/or consequential damages. This warranty gives you specific legal rights. This limited warranty is freely transferable during the term of the warranty period. Customer may have additional rights, which vary from state to state.

In the event that this product was manufactured for export and sale outside of the United States or its territories, then this limited warranty shall not apply. Removal of the serial number on this product, or purchase of this product from an unauthorized dealer, will void this limited warranty. Periodically, this warranty is updated. To obtain the most recent version of QSC's warranty statement, please visit www.qscaudio.com. Contact us at 800-854-4079 or visit our web site at www.qscaudio.com.

© Copyright 2010, QSC Audio Products, LLC
QSC is a registered trademark of QSC Audio Products, LLC
"QSC" and the QSC logo are registered with the U.S. Patent and Trademark Office
All trademarks are the property of their respective owners.

Introduction

These rugged, fan-cooled, 2-channel, 2RU amplifiers provide high-value performance and power in a strong, compact chassis. The series comprises four models: the CMX 300V, CMX 500V, CMX 800V and CMX 2000V. The CMX 2000V is covered in a separate manual.

Features

- Independent, user-defeatable clip limiters
- Fully selectable low-frequency filtering; choice of 30 or 50 Hz roll-off
- Stereo (dual-channel), parallel-input, or Bridge Mono operating modes
- Balanced inputs – XLR, ¼" (6.3 mm) TRS, and barrier strip
- Pluggable terminal block and Speakon™ outputs
- 21 detent gain knobs
- Front panel LED indicators for signal and clip and power
- Attenuation control security plate

Stereo mode, both channels driven	CMX 300V	CMX 500V	CMX 800V
8Ω / FTC 20 Hz –20 kHz / 0.1% THD	185 W	260 W	450 W
8Ω /EIA 1 kHz / 0.1% THD	200 W	300 W	500 W
4Ω / FTC 20 Hz – 20 kHz / 0.1% THD	280 W	400 W	650 W
4Ω /EIA 1 kHz / 0.5% THD	300 W	500 W	800 W
2Ω /EIA 1 kHz / 1% THD	430 W	700 W	1200 W
70V Direct Drive /EIA 1 kHz / 1% THD	-	-	400 W

- Table 1 -

Front Panel

1. Power switch
2. Power indicator LED
3. Cooling vents
4. Clip and Signal indicator LEDs, (Channel 1)
5. Attenuation control (Channel 1)
6. Clip and Signal indicator LEDs, (Channel 2)
7. Attenuation control (Channel 2)
8. Lockout plate retention screw

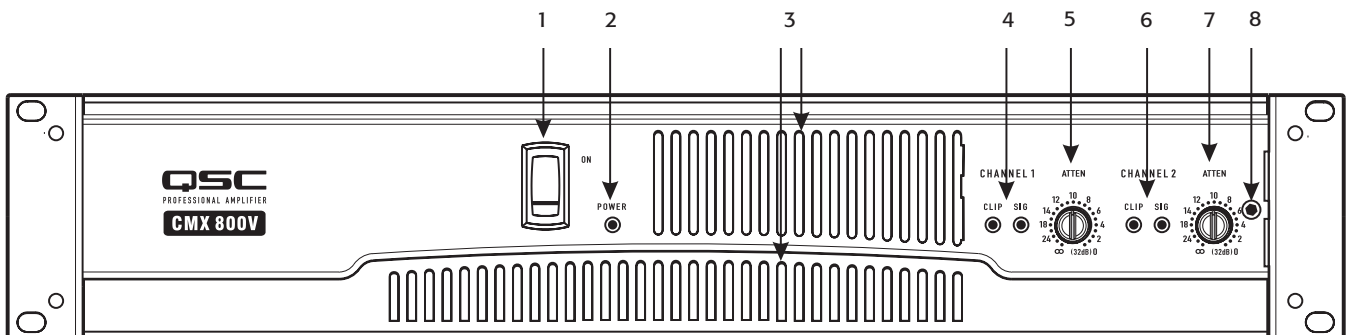

- Figure 1 -

Back Panel

- Barrier strip input
- XLR inputs, Channels 1 and 2
- Configuration dip switches
- TRS inputs, Channels 1 & 2
- Fan
- Speakon™ output, Channel 1 and 2
- Terminal block connector outputs, Channels 1 and 2
- Circuit Breaker
- Serial number label
- Configuration switch chart
- IEC power inlet (power cord connector)

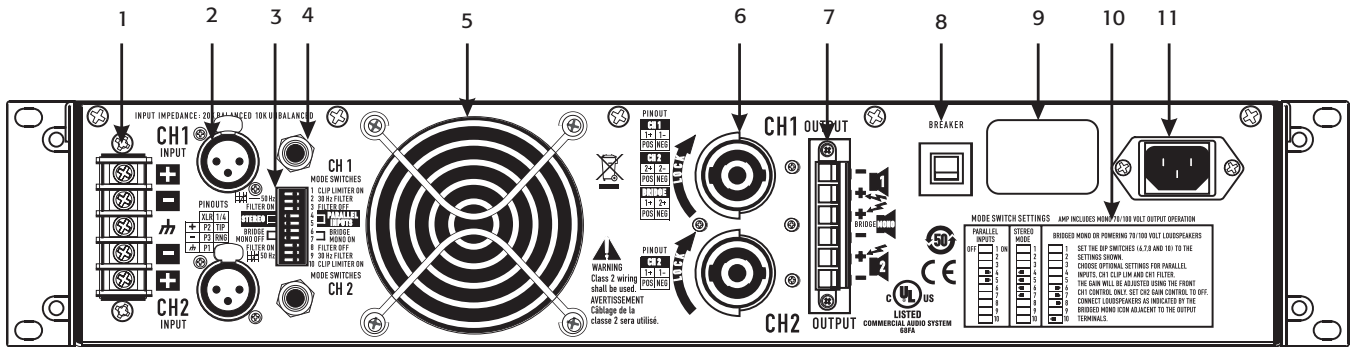

- Figure 2 -

Features and setup

Clip Limiter

What it is

When the audio signal drives the amplifier's output circuit beyond its power capability, it clips, flattening the peaks of the waveform. The clip limiter detects this and reduces the gain to minimize the amount of overdrive. To preserve as much of the program dynamics as possible, limiting reduces the average program level until peaks barely clip.

Each channel has its own clip limiter, and you can switch it on or off independently, as shown in (Figure 3).

When to use it (or not)

When driving full-range speakers, clip limiting reduces high-frequency distortion caused by bass overloads. It also protects higher frequency drivers from excess overdrive and harsh clipping harmonics.

When driving subwoofers, some users let the amplifier clip without limiting because it gives extra "punch" to kick drums and similar sounds.



CAUTION: In bi-amp systems, excessive limiting will affect the frequency balance.

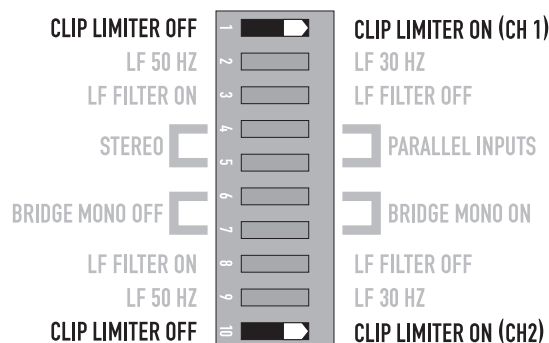

- Figure 3 -

Input Filter

What it is

The low-frequency (LF) filter rolls off signals below either 30 Hz or 50 Hz (Figure 6 and 7). This improves bass performance by limiting sub-audio cone motion, making more power available for the speakers' rated frequency range.

The filter settings for each channel are controlled individually through the DIP switch settings shown in (Figure 4). When the filter is turned off (Figure 5), a 5 Hz roll off protects against DC or deep sub-audio inputs.

When to use it (or not)

As a rule, your speakers will sound better with proper filtering. Unless you already have filtering in a preceding device, match the setting to the low frequency rating of your speakers. Vented (bass reflex, ported, etc.) speakers are especially sensitive to cone over-excitation at frequencies below their rated limit.

The 50 Hz filter works well with most compact full-range speakers, and has a slight boost at 100 Hz for greater fullness. The 30 Hz filter is intended for subwoofers and large full-range cabinets. The "off" position should be used only for applications such as studio playback monitoring, where you need to know if there are unwanted sub-audio signals present in your mix.

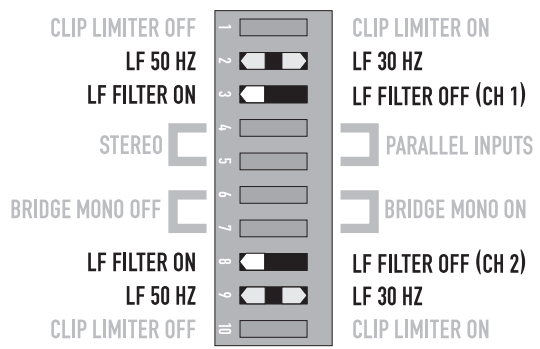

- Figure 4 -

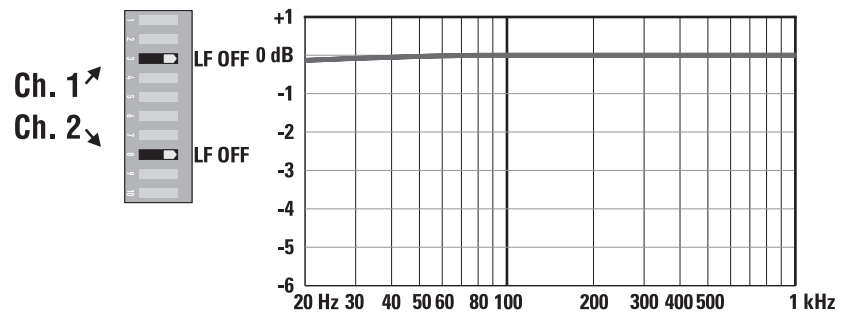

- Figure 5 -

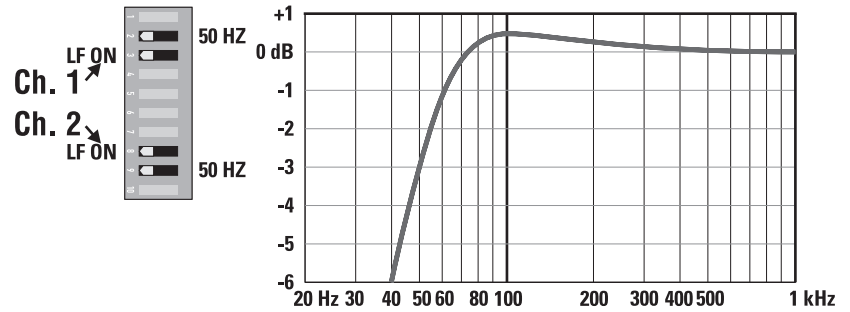

- Figure 6 -

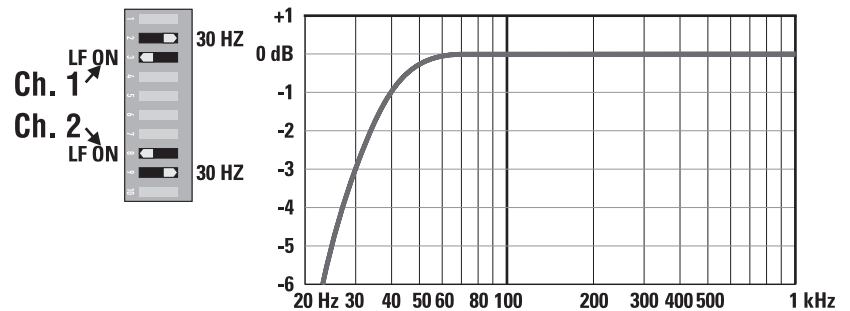

- Figure 7 -

Parallel Input Mode

What it is

The Parallel Input switches let you operate the amplifier in Parallel mode, delivering the same signal to both channels without using a Y cable. Each channel drives its own speaker load, with independent gain, filtering, and clip limiting.

Set switch positions 4 and 5 to "PARALLEL INPUTS" to couple the inputs together (Figure 8). Turn the switches to "STEREO" for stereo, bi-amping, or other 2-channel modes.

With the inputs in parallel, you can use the other set of input connectors to carry the signal to other amps (Figure 9). This is often called a "daisy-chain."

When to use it

Use the Parallel mode when driving two speakers with one input signal (Parallel mode) while keeping separate control of both channels' gain, filtering, and limiting. Use Parallel mode and Bridge Mono mode to patch the signal to additional amplifiers through the extra input jacks.

Note: If you're using a balanced signal, use only balanced patch cables; even one unbalanced cable will unbalance the entire signal chain, possibly causing hum.

Note: Turn off the "Parallel Inputs" switches when feeding the amp two separate signals.

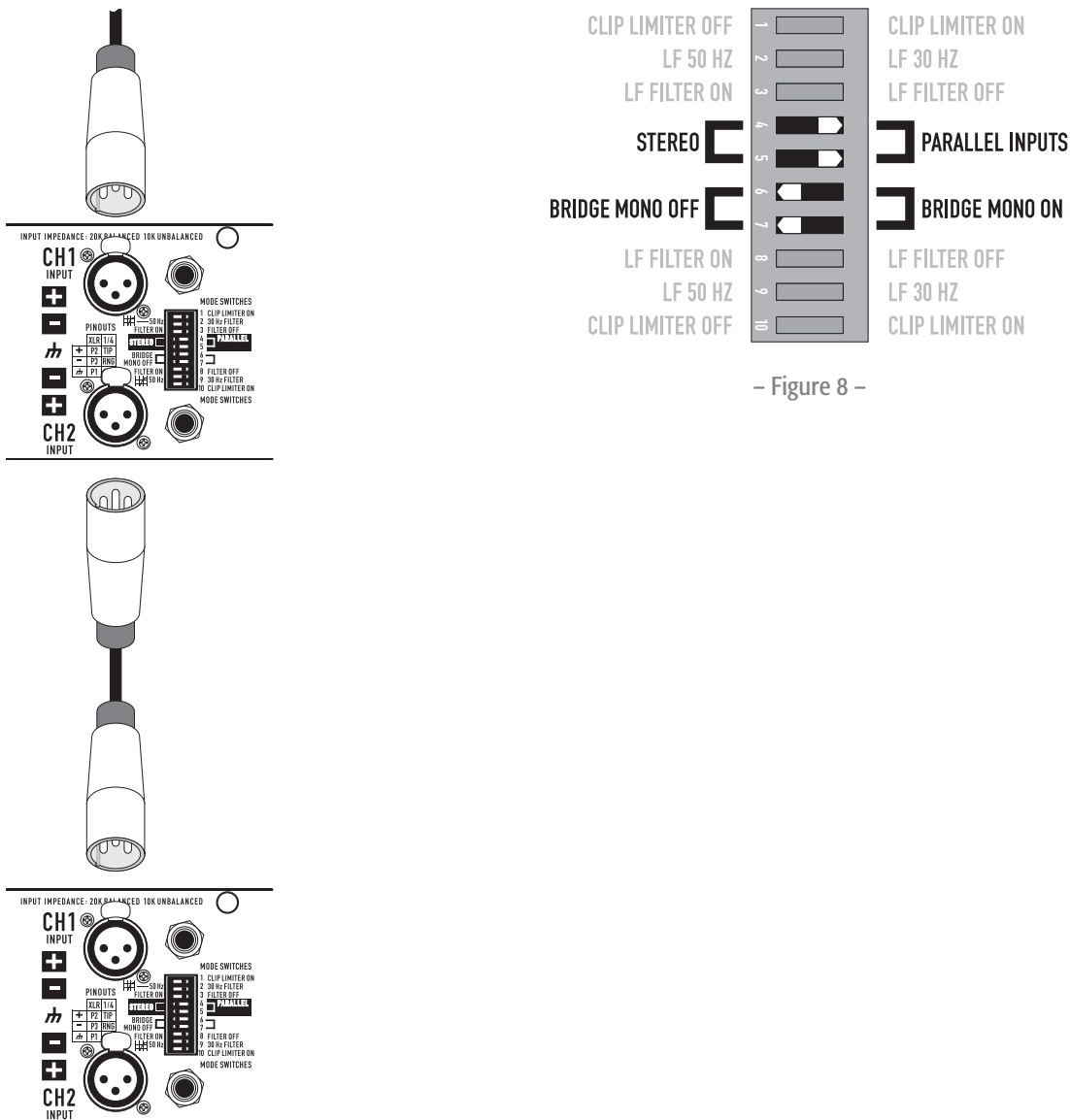

- Figure 8 -

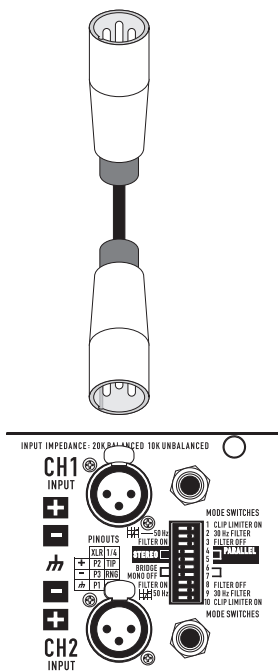

- Figure 9 -

Bridge Mono Mode

What it is

Bridge Mono mode combines the power of both amp channels into one speaker, resulting in twice the voltage swing, four times the peak power, and approximately three times the sustained power of a single channel. This mode uses Channel 1's input, attenuation control, input filter, and clip limiter; Channel 2's dip switch settings should be in the OFF position, the attenuation control should be at maximum attenuation (Figure 10 and 11).

When to use it (or not)

Use Bridge Mono mode to deliver the power of both channels to a single 8 or 4Ω load. Set switch positions 6 and 7 to BRIDGE MONO ON (Figure 10). Use Channel 1's inputs, and connect the speaker as shown in (Figure 12 and 13).

Bridge Mono Precautions

This mode puts a high demand on the amplifier and speaker, Excessive clipping may cause protective muting or speaker damage. Be sure the speaker has a sufficient power rating.

Output voltages greater than 100 volts RMS are available between the bridged terminals of the CMX 800V. CLASS 3 wiring methods (NEC 1999), as specified in accordance with national and local codes, must be used to connect the speaker.

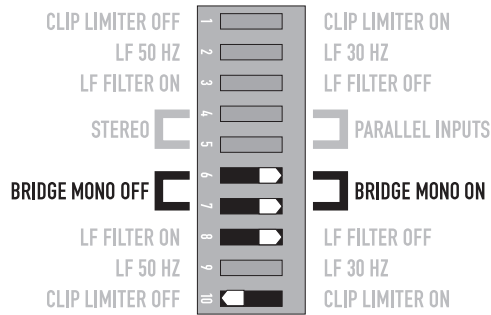

- Figure 10 -

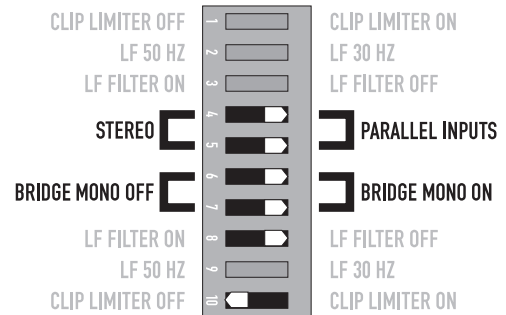

- Figure 11 -

Channel 2 settings, switches 8, and 10 are set to off.

To patch the signal to additional amplifiers, use the parallel input switches described under Parallel Input Mode.

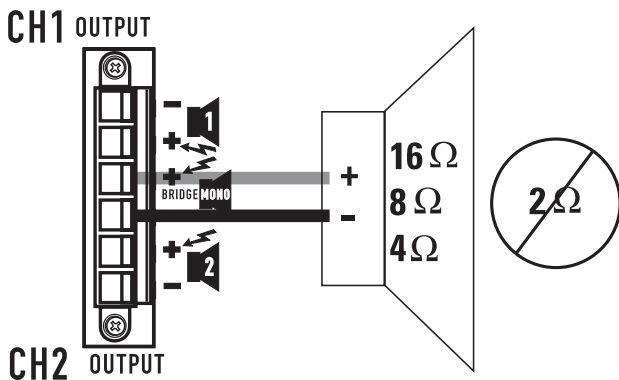

- Figure 12 -

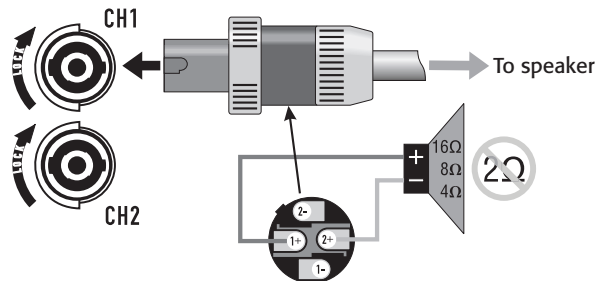

- Figure 13 -

The Difference Between Modes

Stereo Mode

Stereo mode is the typical way of using the amplifier. Each channel is fully independent. Separate signals connect at the inputs, the attenuation knobs control their respective channels, and separate speakers connect to each output. The dip switches are set as shown in (Figure 14), a schematic illustration in (Figure 15).

Examples:

- Two-channel (stereo) playback.
- Two independent mono signals, such as main and monitor mixes.
- Bi-amped operation, with the low frequencies in Channel 1 and the highs in Channel 2.

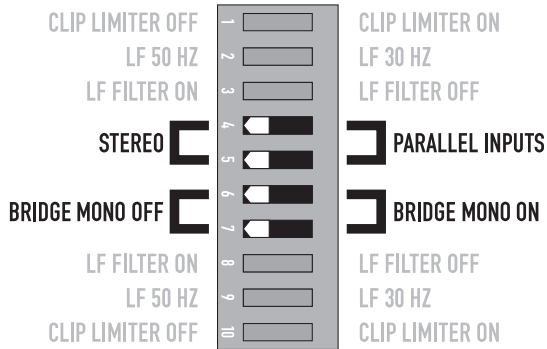

- Figure 14 -

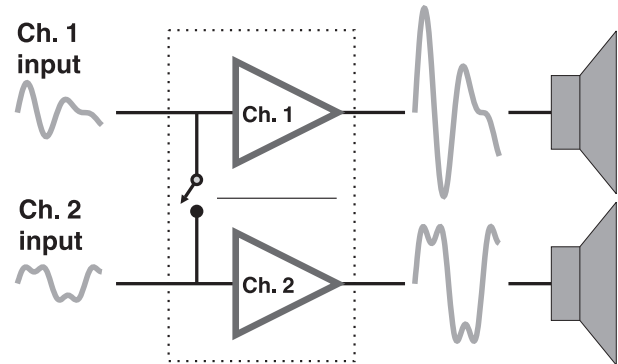

- Figure 15 -

Parallel Input Mode

This mode is similar to the Stereo mode, except that the inputs for Channel 1 and Channel 2 are internally connected together. A signal into Channel 1 jack drives both channels directly (Figure 16). Use Channel 1 Input, do not connect different sources to both channels. Each channel's attenuation control still functions as usual, and each channel feeds its own speaker load. The dip switches are set as shown in (Figure 17).

In Parallel mode, you can patch the input signal on to additional amplifiers by using any of the remaining input jacks. See Ch. 2 in (Figure 16).

Example:

- One mono signal driving both channels, with independent attenuation control for each speaker system.

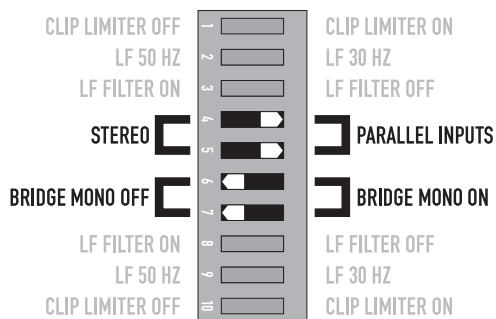

- Figure 17 -

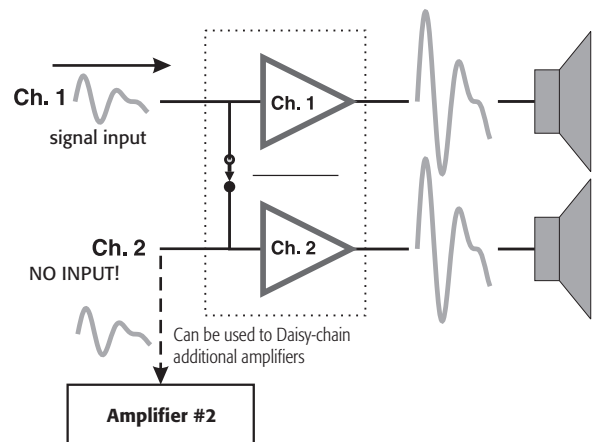

- Figure 16 -

Bridge Mono Mode

This mode combines the full power capabilities of both channels into a single speaker system. The amplifier internally re-configures so that both channels operate as a unit. This delivers double the output voltage, resulting in four times the peak power and three times the sustained power into a single 8 or 4Ω speaker load. The Bridge Mono mode section on page 7 describes the special speaker connection used.

Examples:

- Driving a single 8Ω speaker with the combined 4Ω power of both channels.
- Driving a single 4Ω speaker with the combined 2Ω power of both channels.

Precautions:

- Bridge Mono mode makes it possible to drive thousands of watts into a single speaker. AC current consumption will usually be higher. Avoid excessive signal level, and make sure the wiring and speaker can handle the power.
- If the load is 4Ω or less and prolonged overloads occur, the amplifier will probably mute for several seconds during peaks, and the circuit breaker may trip.
- Do not use 2Ω loads.
- Ensure Channel 2 dip switches are set to off (Figure 18), and Channel 2 attenuation control is set to maximum attenuation.

See the additional Bridge Mono precautions on page 7.

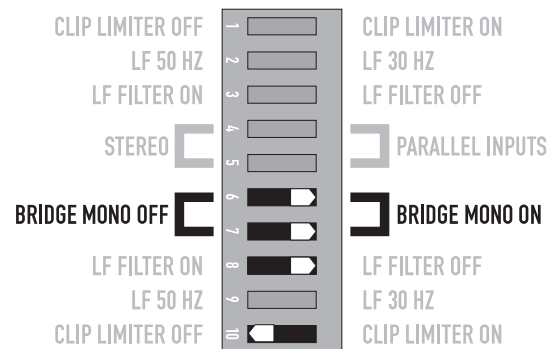

– Figure 18 –

Set Channel 2 dip switches, 8 and 10, to off.

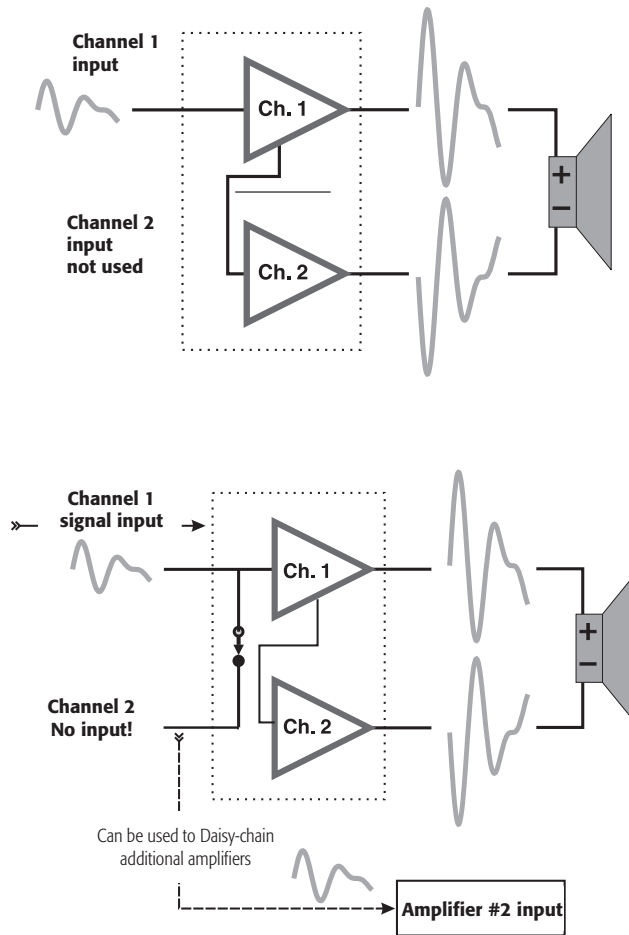

- Figure 19 -

Distributed Constant Voltage Outputs

70 Volt Operation:

The CMX 300V and 500V must be configured for Bridge Mono mode for 70 Volt operation. Please refer to the above section on Bridge Mono mode for proper setup configuration.

The CMX 800V can operate in 70 Volt operation in Stereo mode or Bridge Mono mode.

100 Volt Operation:

The CMX 500V and CMX 800V must be configured for Bridge Mono mode for 100 Volt operation. Please refer to the Bridge Mono mode section for proper setup configuration.

Specifications	CMX 300V	CMX 500V	CMX 800V
Stereo Mode (Both Channels Driven)			
70 Volt	-	-	400 W
100 Volt	-	-	-
Bridge Mono Mode			
70 Volt	600 W	1200 W	2000 W
100 Volt	-	600 W	2300 W

- Table 2 -

Installation

Rack mounting of the amplifier is optional.

Use four screws and washers when mounting the amplifier to the front rack rails.

Support the amp at the rear also, especially in mobile and touring use; rear rack mounting ear kits are available from QSC's technical services department or by special order from your dealer or distributor. Use the dimensions (Figure 20 and 21) for planning.

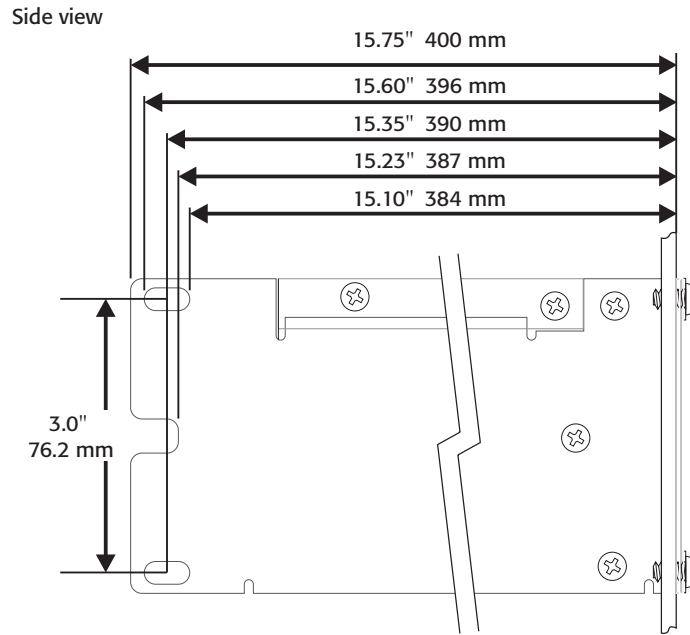

- Figure 20 -

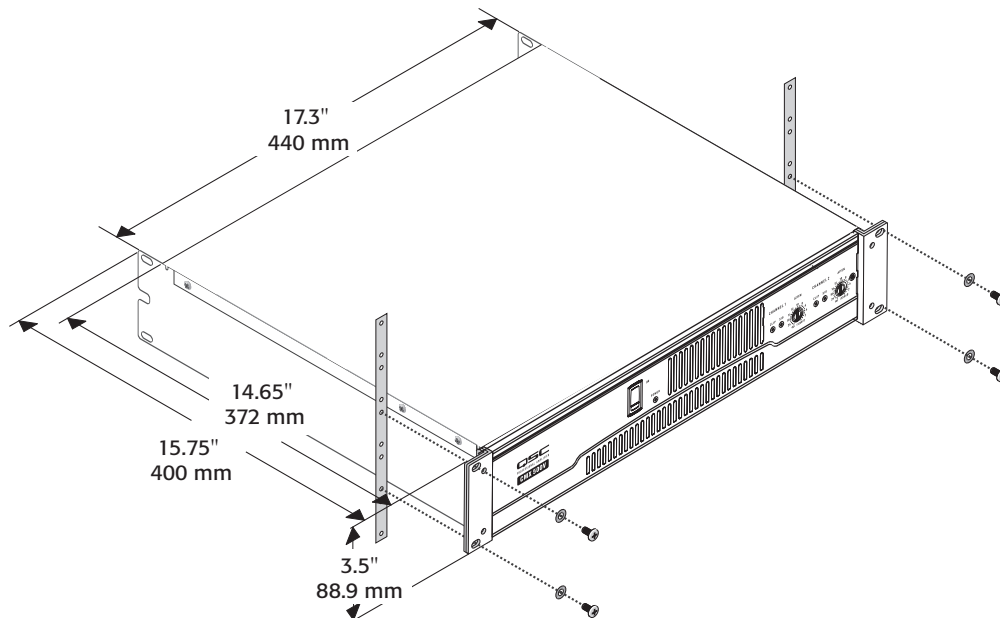

- Figure 21 -

Connections

Inputs

Each channel has active balanced XLR and 1/4" (6.3 mm) inputs wired in parallel (Figure 22). The input impedance is 20 kΩ balanced, 10 kΩ unbalanced.

Balanced signals are less prone to AC hum, but unbalanced signals can be suitable for short cable runs. The signal source's output impedance should be less than 600Ω to avoid high frequency loss in long cables.

Balanced Inputs

Use the XLR or 1/4" (6.3 mm) TRS input jacks, or the barrier strip (Figure 25).

Unbalanced Inputs:

Connect the unused side (Pin 3) of the balanced input to ground (Pin 1), as shown in (Figure 23).

A tip-sleeve 1/4" (6.3 mm) connector will correctly terminate the unused side of the input (Figure 26).

For Stereo operation, use the inputs for both Channel 1 and Channel 2. For Parallel or Bridge Mono operation, use the Channel 1 input.

See the section on operating modes for more information. To patch the audio signal to other amps (Parallel and Bridge Mono modes only), see the instructions for using Parallel Inputs on page 6.

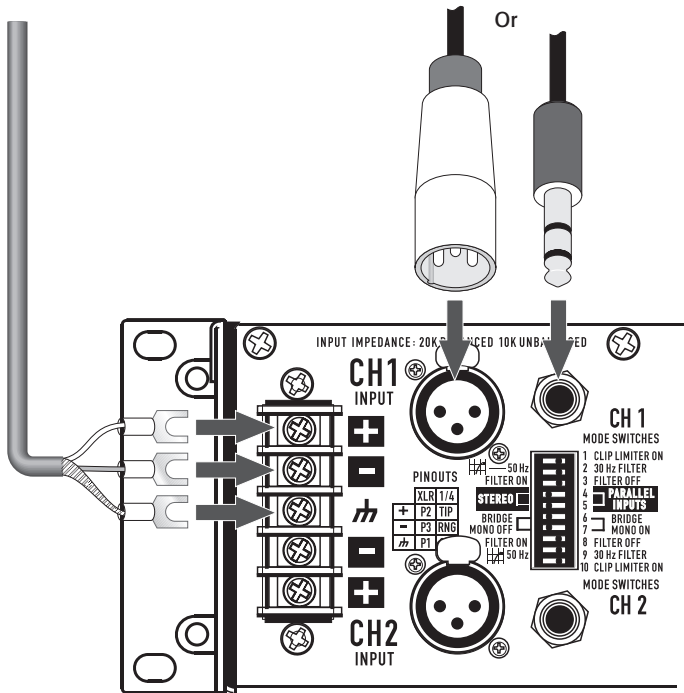

- Figure 22 -

XLR unbalanced
Jumper pin 1 to pin 3

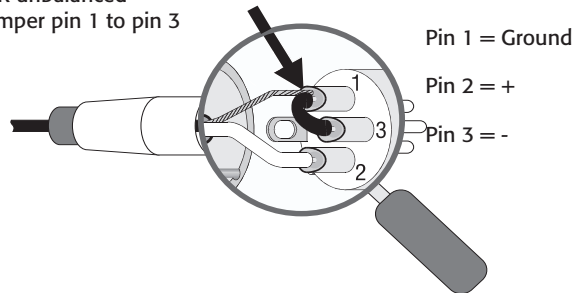

- Figure 23 -

TRS unbalanced
No modification needed

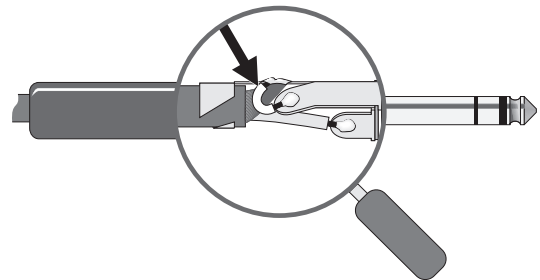

- Figure 24 -

Balanced

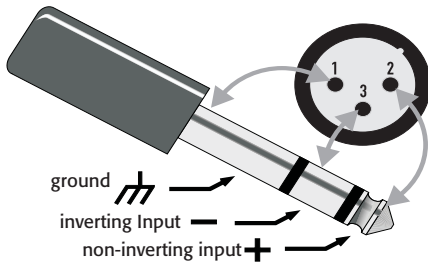

- Figure 25 -

Unbalance

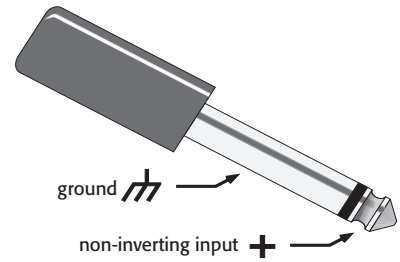

- Figure 26 -

Speakon™ Outputs

CMX amplifiers offer a choice of output connections, with two Neutrik NL4MD Speakon™ jacks and a Terminal Block connector.

The Speakon™ connector is designed specially for high-power speaker connections. It locks in place, prevents shock hazard, and assures the correct polarity.

The upper Speakon™ jack has both Channel 1 and Channel 2 outputs, so it is especially useful for Parallel, bi-amp, or Bridge Mono mode operation (see Bridge Mono mode operating precautions on page 7). The other Speakon™ carries only the output from Channel 2.

For easier insertion, use the newer-style NL4FC Speakon™ connectors with quick-lock thumb latches (**Not shown**).

Speaker Cabling

Larger wire sizes and shorter lengths minimize both loss of power and degradation of damping factor. Do not place speaker cables next to input wiring.



WARNING: To prevent electric shock, do not operate the amplifier with any of the conductor portion of the speaker wire exposed.

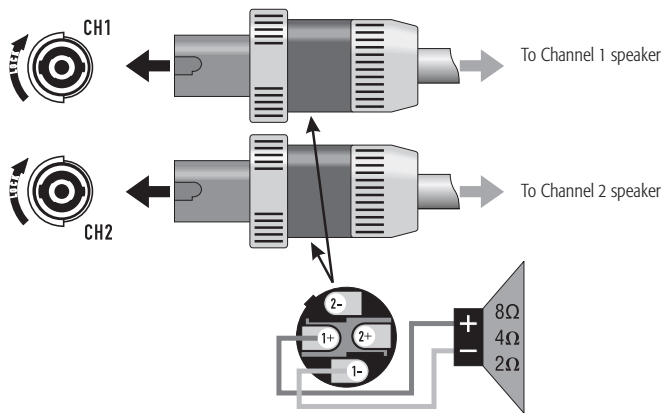

- Figure 27 -

2 channels & 2 Speakon™ connectors
(Stereo, bi-amp, or parallel mode)

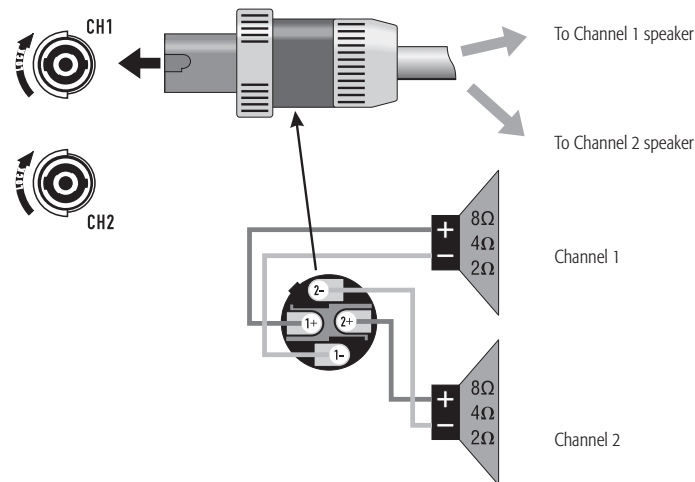

- Figure 28 -

2 channels & 1 Speakon™ connectors
(Stereo, bi-amp, or parallel mode)

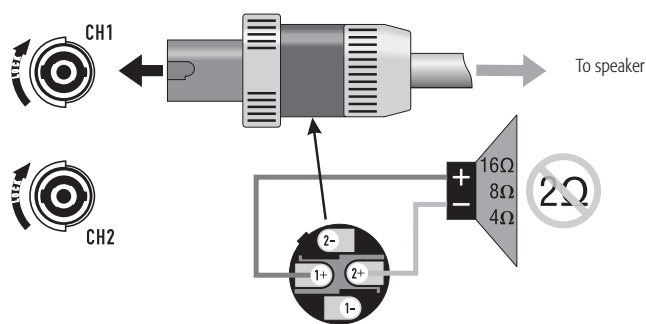

- Figure 29 -

Bridge Mono mode

Terminal Block Connector

The terminal block connector requires the following assembly.

1. Strip the wires to 7 ~ 8 mm.
2. Insert the wires into the male part of the connector according to the Mode you are using. See below.
3. Use a flat-tip screwdriver to secure the wires. Tighten the screws to 6 in.-lbs.
4. Insert the plug into the receptacle on the amplifier.
5. Use a flat-tip screwdriver to secure the connector. Tighten the screws to 6 in.-lbs.

Stereo and Parallel Mode: Wire as shown by loudspeaker symbols 1 and 2, and the solid wires in (Figure 30).

Bridge Mode: Wire as shown by Bridge Mono loudspeaker symbol, and the dashed wires in (Figure 30).

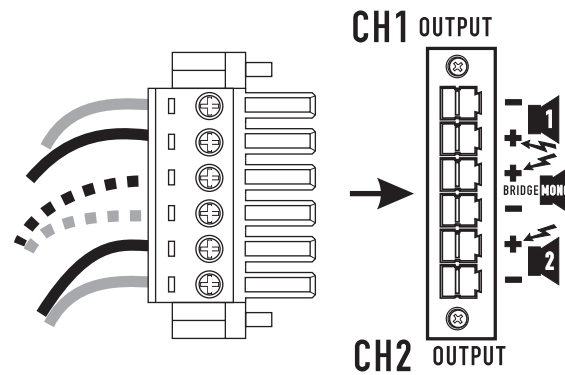

- Figure 30 -

Terminal Block Connector Wiring	UL	IEC
Wire range	-	6 mm ²
Solid wire (AWG)	28 - 10	-
Stranded wire (AWG/mm ²)	28 - 10	-
Torque (lb.-in.)	6	-
Wire strip length	7 - 8 mm	-

- Table 3 -

Operating Voltage

(AC Mains)

Make sure you connect the amplifier to the correct AC line voltage, as shown on the serial number label. Connecting to the wrong line voltage is dangerous and may damage the amplifier (Figure 31).

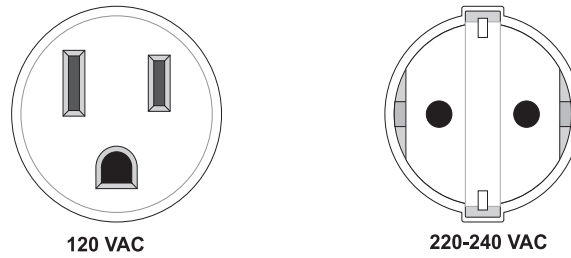

– Figure 31 –

Operation

AC Power Switch

Before applying power, check all connections and turn the attenuation controls fully counter clockwise to maximum attenuation.

One second of muting is normal when the amp is turned on or off (Figure 32).

Attenuation Controls

The controls are marked with a scale indicating attenuation. Maximum attenuation is fully counter clockwise, minimum attenuation is fully clockwise. (Figure 33).

LED Indicators

The green SIGNAL LED indicators light at approximately 0.1% of full power.

The red CLIP LED indicator flashes during overload (clipping).

If the amplifier's protection circuitry triggers protective muting, the signal and clip LEDs will not light. If this occurs during use, see the Troubleshooting section on pages 16 – 17.

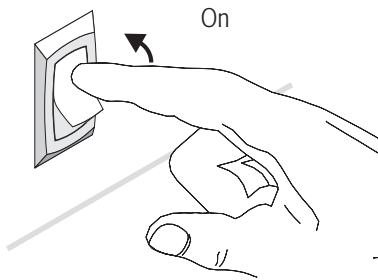

– Figure 32 –

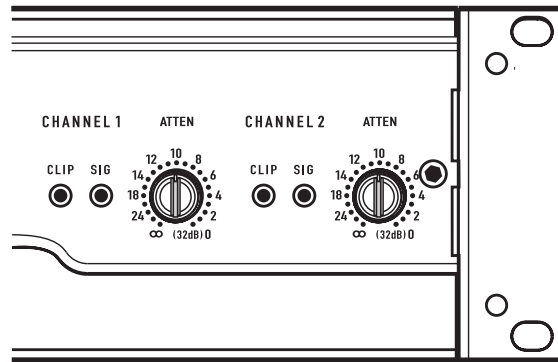

– Figure 33 –

Model Maximum Voltage Gain	
CMX 300V	31.6 x (30 dB)
CMX 500V	40 x (32 dB)
CMX 800V	46 x (33 dB)

– Table 4 –

Fan cooling

The fan speed varies automatically to maintain safe internal temperatures. Keep the front and rear vents clear to allow full air flow. Hot air exhausts out the front of the amp so it does not heat the interior of the rack. Make sure that plenty of cool air can enter the rack, especially if there are other units which exhaust hot air into it.

Safe operating levels

The amp's protective muting system guards against excessive internal temperatures. With normal ventilation and 4 - to 8Ω loads, the amplifier will handle any signal level including overdrive-but make sure that the speakers can handle the full power! However, lower load impedances and higher signal levels produce more internal heating. Into 2Ω loads, frequent or prolonged clipping (indicated by constant flashing of the red CLIP LED) may trigger protective muting. Bridged mono mode doubles the output impedance of the amp; 4Ω is the minimum load impedance. Heavy clipping may cause muting. If this happens, see the Troubleshooting section below through the following page.

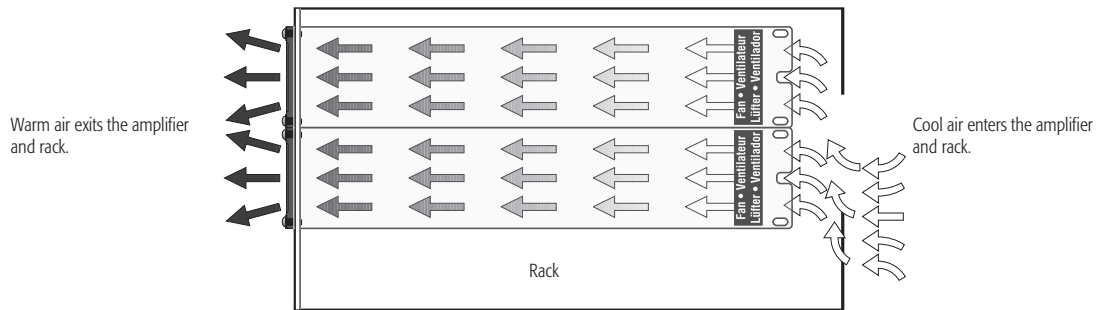

- Figure 34 -

Troubleshooting

Problem: No Sound

Indication: POWER indicator not lit

Check the AC plug. Also check the circuit breaker on the rear panel.

Confirm that the AC outlet works by plugging in another device. If too many amplifiers are used on one outlet, the building's circuit breaker may trip and shut off power.

An overload in Bridged Mono mode may cause the amplifier to click off for several seconds. Check the load impedance (4Ω minimum), or reduce signal level.

An amplifier which keeps shutting off may have a serious internal fault. Turn it off, remove AC power, and have the amplifier serviced by a qualified technician.

Indication: SIGNAL LED responding to signal level

If the green SIGNAL indicators are lighting normally, the fault is somewhere between the amp and the speaker. Check the speaker wiring for breaks. Try another speaker and cable.

Indication: SIGNAL LED not lit

If the green POWER indicator LED is lit and the fan is running, yet the signal LEDs indicate no signal, check the input. Make sure the signal source is operating and try another input cable. Connect the source to another channel or amplifier to confirm its operation.

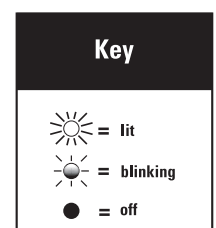

Indication: CLIP LED flashing

If the red CLIP indicator flashes when signal is applied, the amplifier output may be shorted. Check the speaker wiring for stray strands or breaks in the insulation.

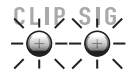

Indication: CLIP LEDs bright and steady

The amplifier is in protective muting.

One second of muting is normal when the amp is turned on or off.

Overheating will cause protective muting. The fan will be running at full speed and the chassis will be hot to the touch; sound should resume within a minute as the amplifier cools to a safe operating temperature. Check for proper ventilation. If the fan isn't running at all, the amplifier requires servicing.



Problem: Distorted Sound

Indication: CLIP LED flashing

If the red CLIP indicator flashes before the signal indicator does, the load impedance is abnormally low or shorted. Unplug each speaker one-by-one at the amplifier. If the CLIP LED goes out when you disconnect a cable, that cable or speaker is shorted. Try another cable and speaker to locate the fault.



Indication: CLIP LED not flashing

This could be caused by a faulty speaker or loose connection. Check the wiring and try another speaker.

The signal source may be clipping. Keep the amplifier attenuation controls at mid point so that the source does not have to be overdriven.



Problem: No channel separation

Check the switch settings on the back of the amplifier. Make sure the "Parallel Input" and "Bridge Mode" switches are OFF in dual-channel, bi-amp, or stereo use where different signals go to each channel.

Make sure other equipment in the signal path, such as mixers, preamps, etc., are set for stereo, not mono.

Problem: Hum

Move cabling and signal sources to identify "hot spots" in the system. Cables with faulty shielding are a frequent entry point for hum.

Problem: Hiss

Unplug the amplifier input to confirm that the hiss is coming from the source or a device upstream; erratic or popping noises indicate an electronic fault in the offending unit.

To keep the normal noise floor low, operate the primary signal source at full level, without clipping, and avoid boosting the signal further between the source and the amplifier.

Problem: Squeals and feedback

Microphone feedback should be controlled with mixer controls. If noise continues to build up with zero mic gain, there is a serious fault in the signal processors or cables. Working in succession from the signal source towards the amplifier, check each device in the signal path by reducing its gain or unplugging it.

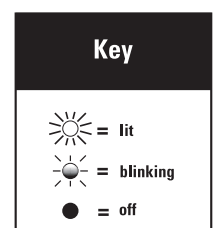

Specifications

	CMX 300V	CMX 500V	CMX 800V
Stereo Mode (both channels driven)			
8Ω / FTC 20 Hz - 20 kHz / 0.1% THD	185 W	260 W	450 W
8Ω / EIA 1 KHZ / 0.1% THD	200 W	300 W	500 W
4Ω / FTC 20 HZ - 20 KHZ / 0.1% THD	280W	400 W	650 W
4Ω / EIA 1 KHZ / 0.5% THD	300 W	500 W	800 W
2Ω / EIA 1 KHZ / 1% THD	430 W	700 W	1200 W
70 V - Direct drive / EIA 1 kHz / 1% THD	-	-	400 W
Bridge Mono Mode			
8Ω / FTC 20 Hz - 20 kHz / 0.1%THD	530 W	800 W	1300 W
8Ω / EIA 1 kHz / 0.1%THD	600 W	900 W	1500 W
4Ω / EIA 1 kHz / 1%THD	830 W	1400 W	2400 W
70 V - Direct drive / EIA 1 kHz / 1% THD	600 W	1200 W	2000 W
100 V - Direct drive / EIA 1 kHz / 1% THD	-	600 W	2300 W
Distortion (SMPTE-IM)	< 0.02%	< 0.01%	< 0.01%
Signal to Noise (20 Hz – 20 kHz) 8Ω	> -100 dB		
Input Sensitivity 8Ω	1.15 V (+3.4 dBu)	1.15 V (+3.4 dBu)	1.23 V (+4.0 dBu)
Voltage Gain (8Ω)	30 dB	32 dB	33 dB
Output Circuitry	Class AB	Class AB	2-tier Class H
Power Requirements			
Typical, 1/8 power, pink noise at 4Ω			
120 VAC	4.4 A	5.4 A	6.3 A
230 VAC	2.2 A	2.7 A	3.2 A
Severe, 1/3 power pink noise at 4Ω			
120 VAC	6.6 A	9.6 A	15.6 A
230 VAC	3.3 A	4.8 A	7.8 A
Frequency Response	20 Hz – 20 kHz, +0, -1 dB (LF filter bypassed / 8Ω)	-3 dB points: 5 Hz and 50 kHz	
Damping Factor	> 300 at 8Ω		
Input Impedance (Ω)	10 kΩ unbalanced / 20 kΩ balanced		
Input Clipping	10 Vrms (+22 dBu)		
Cooling	Continuously variable speed fan, back-to-front air flow		
Connectors (each channel)	Input: Active balanced; barrier strip, XLR and ¼" (6.3 mm) - TRS tip and XLR (pin 2 positive) Output: Detachable terminal block and Speakon™		
Controls	Front: AC Switch, Channel 1 and Channel 2 gain knobs Rear: 10-position DIP switch		
Indicators	Power-on: Green LED / Signal: Green LED (1 per channel) / Clip: Red LED (1 per channel)		
Amplifier Protection	Stable into reactive or mismatched loads		
Load Protection	On/off muting, AC Coupling (CMX 300V and CMX 500V), triac crowbar (CMX 800V on each channel)		
Dimensions (HWD)	3.5" (2RU) x 19" x 15.9" (89 mm x 483 mm x 400 mm)		
Weight - Net / Shipping	35 lb (15.9 kg) / 41 lb (18.6 kg)	40 lb (18.2 kg) / 46 lb (20.9 kg)	44.5 lb (20.2 kg) / 50.5 lb (23.0 kg)



Mailing Address:

QSC Audio Products, LLC
1675 MacArthur Boulevard
Costa Mesa, CA 92626-1468 USA

Telephone Numbers:

Main Number: (714) 754-6175
Sales & Marketing: (714) 957-7100 or toll free (USA only) (800) 854-4079
Customer Service: (714) 957-7150 or toll free (USA only) (800) 772-2834

Facsimile Numbers:

Sales & Marketing FAX: (714) 754-6174
Customer Service FAX: (714) 754-6173

World Wide Web:

www.qscaudio.com

E-mail:

info@qscaudio.com
service@qscaudio.com

Free Manuals Download Website

<http://myh66.com>

<http://usermanuals.us>

<http://www.somanuals.com>

<http://www.4manuals.cc>

<http://www.manual-lib.com>

<http://www.404manual.com>

<http://www.luxmanual.com>

<http://aubethermostatmanual.com>

Golf course search by state

<http://golfingnear.com>

Email search by domain

<http://emailbydomain.com>

Auto manuals search

<http://auto.somanuals.com>

TV manuals search

<http://tv.somanuals.com>