

Airborne Heavy Duty 802.11b/g Wireless Device Server

ABDG-SE-HD101 series



Durable, heavy duty enclosure for extreme conditions

Add WiFi communications to existing telematics and asset management systems with the external Airborne Heavy Duty Wireless Device Servers. A versatile choice for remote management, the Heavy Duty serial bridge includes 802.11b/g technology that enables systems complete wireless access and control of virtually any type of equipment with a serial port.

With a durable enclosure, it shields the device from external elements, including water, dust and other environmental threats. This powerful tool is an ideal solution for vehicle mounting, industrial shop floors or any other extreme environment surroundings.

802.11 wireless connectivity

The Airborne Heavy Duty Wireless Device Server is a serial to 802.11 bridge capable of linking a host system with a serial connection to a wireless 802.11 network.

The device includes a physical interface to the serial host through a 12-pin connector integrated into the enclosure. The 802.11 RF interface is provided by an enclosure mounted RP-SMA socket.

The device is supplied in a Deutsch EEC-325X4B enclosure and is available in both sealed and unsealed versions*.

The wireless device server supports a single RS-232 interface with isolated inputs and a power supply capable of meeting the SAE J1455 specification (+5 to +36 VDC). It's interface also supports controls for host based remote management.

Applications

The Airborne bridge enable telematics systems to connect to corporate and public wireless LAN networks, commonly deployed at warehouses, ports and transit centers.

Ruggedized hardware is incorporated for harsh environmental conditions faced by trucks, buses, heavy equipment and automobiles. In addition, the Airborne Heavy Duty Bridge runs directly on vehicle battery power to enable easy integration by telematics solution providers.

* For sealed versions, please contact Airborne Sales Team

KEY FEATURES

- Extended operating temperature range (-40°C to +85°C) and environmental specifications
- Advanced security support includes WEP 64/128, WPA (TKIP), 802.1x (LEAP)
- SAE J1455 compatible power supply
- Ruggedized Deutsch enclosure and connector
- 802.11b/g compliant radio
- Quick time to market & reduced development costs
- FCC Part 15 Class B Sub C Approval
- Reduces need for RF and communications expertise
- RP-SMA connector available for cable or direct antenna connection
- Device integration does not require OS specific drivers

Model Selection Guide

Model No.	WiFi		Interface	Security			RoHS Compliant
	802.11b	802.11b/g	RS-232	WEP (64 & 128 bit)	WPA	LEAP	
ABDG-SE-HD101		●	●	●	●	●	●
<i>To evaluate all available features and receive evaluation tools, order below.</i>							
ABEG-SE-HD101	Accessory Kit, 802.11b/g Wireless Device Server						



Block Diagram

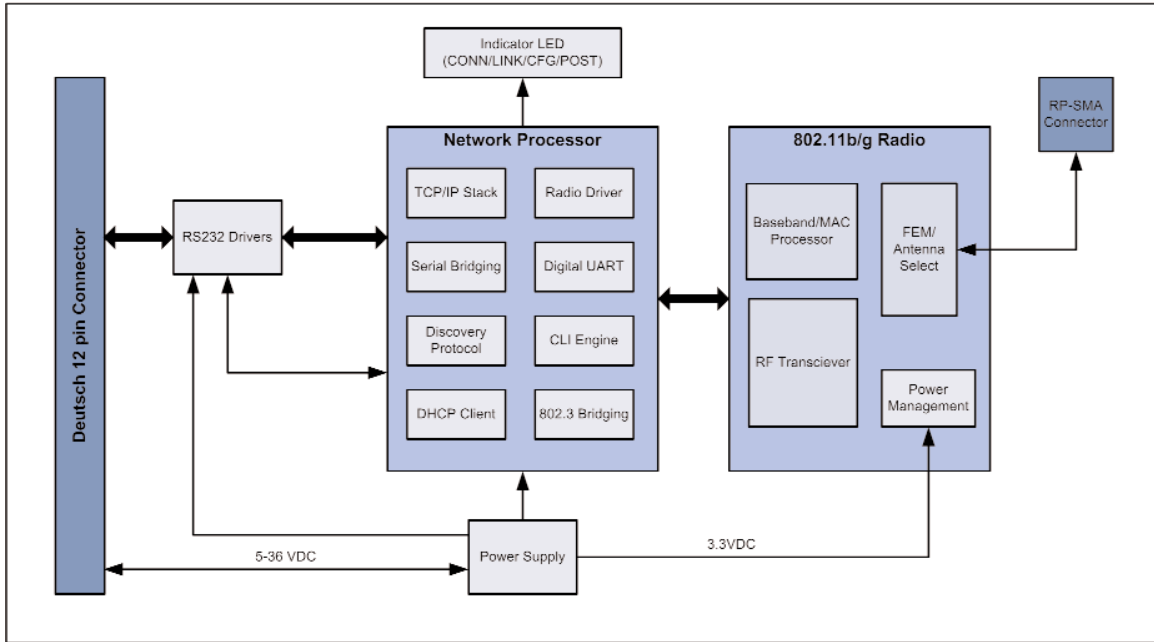

Mechanical Outline

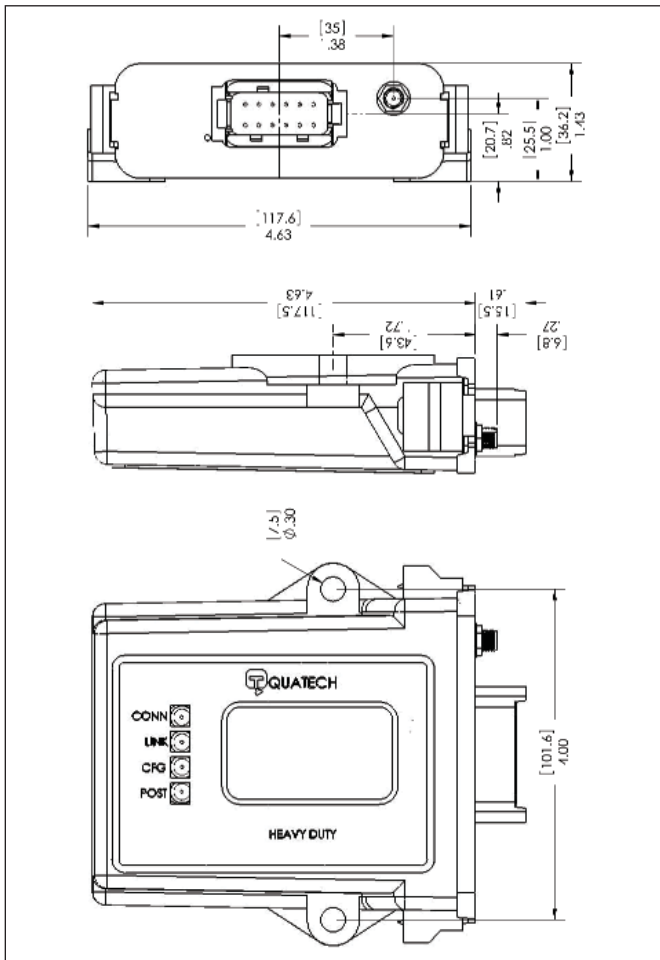

Specifications

Serial Interface	RS-232
Wireless Network Interface	IEEE 802.11b/g DSSS, OFDM, WiFi Compliant
Frequency	2.4 - 2.4835 GHz (US, Europe, Canada, Japan) 2.471 - 2.497 GHz (Japan)
Channels	11 - US/Canada; 13 - Europe; 14 - Japan; 4 - France
Wireless Raw Data Rates	802.11b mode: 11Mbps, 5.5Mbps, 2Mbps, 1Mbps 802.11g mode: 54, 48, 36, 24, 12, 9, 6 Mbps
RF Output Power	802.11b mode: +18dBm (typ) with 3dBi antenna 802.11g mode: +15dBm (typ) with 3dBi antenna
Security	None, WEP64/128, WPA Personal (TKIP), WPA-LEAP (TKIP)
Antenna	Integrated RP-SMA connector
Protocols	TCP/IP, ARP, ICMP, DHCP, DNS, HTTP, UDAP, UDP, Discovery
Data Transfer Protocol	TCP/IP, HTTP, UDP
Status Indicators	POST, CFG, LINK, CONN
Power Input	5VDC to 36VDC, through Deutsch connector. Line level input control of power supply
Power Consumption	2W max
Device Management	Device discovery, Airborne Control Center application, web interface, plain text Command Line interface, firmware upgrade, OEM configuration utility
Agency Approvals	FCC Part 15 Class B, C/UL, CE
OS Compatibility	AirborneDirect - Win95/ME/NT/2000/XP/Vista and Linux Airborne Control Center - Win 2000/XP
Operating Temperatures	-40°C to +85°C
Storage Temperature	-40°C to +125°C

QUATECH

A DPAC TECHNOLOGIES COMPANY

5675 Hudson Industrial Parkway Hudson, OH 44236

1.800.553.1170 www.quatech.com

Free Manuals Download Website

<http://myh66.com>

<http://usermanuals.us>

<http://www.somanuals.com>

<http://www.4manuals.cc>

<http://www.manual-lib.com>

<http://www.404manual.com>

<http://www.luxmanual.com>

<http://aubethermostatmanual.com>

Golf course search by state

<http://golfingnear.com>

Email search by domain

<http://emailbydomain.com>

Auto manuals search

<http://auto.somanuals.com>

TV manuals search

<http://tv.somanuals.com>