



DSP-200/300
Dual Channel RS-422/485 PCMCIA
Asynchronous Adapter

for PCMCIA Card Standard compatible machines

User's Manual

INTERFACE CARDS FOR IBM PC/AT AND PS/2

QUATECH, INC.
5675 Hudson Industrial Parkway
Hudson, Ohio 44236

TEL: (330) 665-9000
FAX: (330) 665-9010
www.quatech.com

Warranty Information

Quatech Inc. warrants the DSP-200/300 to be free of defects for **one (5) year** from the date of purchase. Quatech Inc. will repair or replace any adapter that fails to perform under normal operating conditions and in accordance with the procedures outlined in this document during the warranty period. Any damage that results from improper installation, operation, or general misuse voids all warranty rights.

The authors have taken due care in the preparation of this document and any associated software program(s). In no event will Quatech Inc. be liable for damages of any kind, incidental or consequential, in regard to or arising out of the performance or form of the materials presented herein and in the program(s) accompanying this document. No representation is made regarding the suitability of this product for any particular purpose.

Quatech Inc. reserves the right to edit or append to this document or the product(s) to which it refers at any time and without notice.

Please complete the following information and retain for your records. Have this information available when requesting warranty service.

Date of purchase: _____

Model Number: DSP-200/300

Product Description: Single Channel Asynchronous RS-422/485
Communications PCMCIA Adapter

Serial Number: _____

CE Declaration of Conformity

Manufacturer's Name: Quatech, Inc.

Manufacturer's Address: 662 Wolf Ledges Parkway
Akron, OH 44311 (USA)

Application of Council Directive: 89/336/EEC

**Standards to which
Conformity is Declared:** * EN50081-1
(EN55022)
* EN50082-1
(IEC 801-2, IEC 801-3, & IEC 801-4)

Type of Equipment: Information Technology Equipment

Equipment Class: Commercial, Residential, & Light
Industrial

Product Name: PCMCIA Card

Model Number : DSP-200/300

Table of Contents

Introduction	1-1
DOS/Windows 3.x	2-2
DSP-200/300 Client Driver for DOS	2-3
Client Driver Installation	2-3
Command Line Options	2-4
Common Problems	2-7
DSP-200/300 Enabler for DOS	2-8
Command Line Options	2-9
Common Problems	2-11
Windows 95/98/Millennium (ME)	3-2
Installing a DSP-200/300 Under Windows 95/98/ME	3-2
DSP-200/300 Resource Settings in Windows 95/98/ME	3-2
Viewing Resource Settings with Device Manager	3-3
Changing Resource Settings with Device Manager	3-3
Frequently Asked Questions	3-6
Windows 2000	4-2
Installing a DSP-200/300 Under Windows 2000	4-2
DSP-200/300 Resource Settings in Windows 2000	4-5
Viewing Resource Settings with Device Manager	4-6
Changing Resource Settings with Device Manager	4-7
Windows NT	5-2
Installing DSP-200/300	5-2
Hardware Information	6-1
Auxiliary Channel Configuration	6-1
Auxiliary Channel: RTS-CTS Handshaking	6-1
Auxiliary Channel: Handshaking Disabled	6-2
Half Duplex Operation	6-3
Termination Resistors	6-5
External Connections	7-2
Specifications	8-2

1. Introduction

The DSP-200/300 is a dual channel RS-422/RS-485 asynchronous serial adapter for systems equipped with PCMCIA Type II and/or Type III expansion sockets. The DSP-200/300 is a PCMCIA Type II (5 mm) card and is PCMCIA PC Card Standard Specification 2.1 compliant.

The DSP-200/300's serial port is implemented using a 16C750 Universal Asynchronous Receiver/Transmitter (UART), which is the recommended communications interface for multitasking environments and with applications involving high data transfer rates.

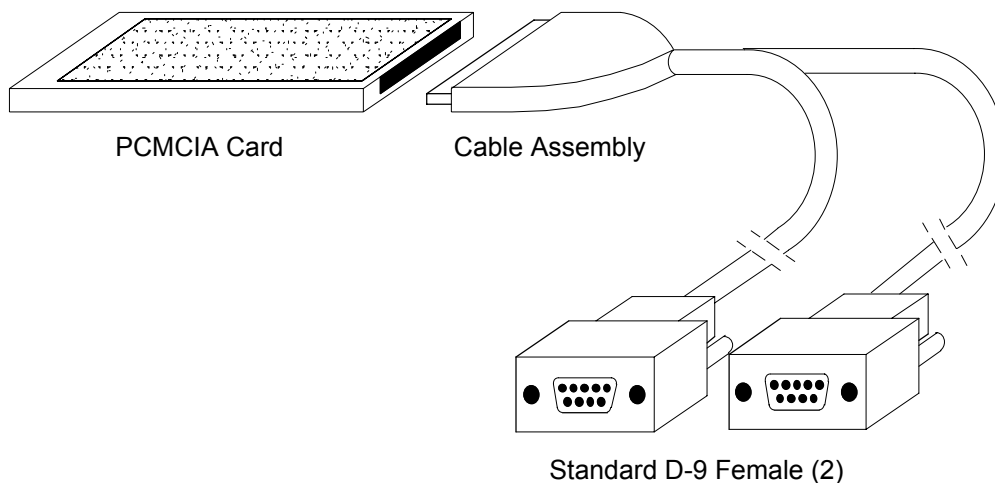

Figure 1. DSP-200/300 Card and Cable Assembly

The DSP-200/300 provides four differential signal pairs (two input and two output): TxD, RxD, AUXOUT, and AUXIN. TxD and RxD are always present at the connector. The AUXOUT and AUXIN signals can be used to support RTS/CTS handshaking, external clocking, or external signal loopback. The default configuration is RTS/CTS handshaking, with RTS transmitted through AUXOUT and CTS received through AUXIN. The role of AUXOUT and AUXIN can be set when the DSP-200/300 is configured.

The DSP-200/300 may be configured to operate in either the Full Duplex or Half Duplex mode; the DSP-200/300 may be configured so that the output drivers are always enabled, RTS or DTR enable the output drivers, or the output drivers are automatically enabled only when data is being transmitted. See the **Hardware Information** section for details on these topics.

This page intentionally left blank.

2. DOS/Windows 3.x

Two configuration software programs are provided with the DSP-200/300: a Client Driver, and a card Enabler. Both of these programs are executed from DOS (before entering Windows) and allow operation of the DSP-200/300 in both the DOS and Windows 3.x environments. For optimal operation, however, the Client Driver is the preferred method of installation and configuration. The table below highlights the differences between these programs.

Client Driver (recommended)	Enabler
File type: DOS device driver	File type: DOS executable
Interfaces to PCMCIA Card and Socket Services software (PCMCIA host adapter independent)	Interfaces directly to Intel 82365SL and other PCIC compatible PCMCIA host adapters
Allows automatic configuration of DSP-200/300 adapters upon insertion (Hot Swapping)	Does not support automatic configuration of adapters upon insertion (Hot Swapping)
Requires PCMCIA Card and Socket Services software	Does not require PCMCIA Card and Socket Services software

Figure 2. Client Driver versus Enabler for DOS/Windows 3.x.

Card and Socket Services software is commercially available from several vendors for most desktop and laptop PCs. If you are unsure whether Card and Socket Services software is currently installed on your system, install the DSP-200/300 Client Driver as discussed in following section. When loaded, the Client Driver will display an error message if Card and Socket Services software is not detected.

2.1 DSP-200/300 Client Driver for DOS

In order to use the DSP-200/300 Client Driver, the system must be configured with Card and Socket Services software. Card and Socket Services software is not provided with the DSP-200/300 but is available from Quatech.

IMPORTANT:

Some versions of Card and Socket Services dated before 1993 do not support general purpose I/O cards. If after careful installation of the Client Driver the adapter does not configure or operate properly, an updated version of Card and Socket Services may be required.

2.1.1 Client Driver Installation

The following procedure is used to install the DSP-200/300 Client Driver:

1. Copy the Client Driver from the DSP-200/300 distribution diskette onto the system's hard drive.
2. Using an ASCII text editor, open the system's CONFIG.SYS file located in the root directory of the boot drive.
3. Locate the line(s) in the CONFIG.SYS file where the Card and Socket Services software is installed.
4. **AFTER** the line(s) installing the Card and Socket Services software, add the following line to the CONFIG.SYS file: DEVICE = *drive:\path*
DSP230CL.SYS *options* where *options* are the DSP-200/300 Client
Driver command line options discussed on the following pages.
5. Save the CONFIG.SYS file and exit the text editor.
6. Insert the DSP-200/300 into one of the system's PCMCIA slots.

NOTE: Since the DSP-200/300 Client Driver supports "Hot Swapping", it is not necessary to have the DSP-200/300 installed when booting the system. By inserting the card before booting, however, the Client Driver will report the adapter configuration during the boot process thereby verifying the changes made to the CONFIG.SYS.

7. Reboot the system and note the message displayed when the DSP-200/300 Client Driver is loaded. If the Client Driver reports an "invalid command line option", correct the entry in the CONFIG.SYS file and reboot the system again. If the Client Driver reports "Card and Socket Services not found", a version of Card and Socket Services must be installed on the system or the DSP-200/300 Enabler program must be used to configure the adapter. If the Client Driver reports the desired adapter configuration, the installation process is complete and the DSP-200/300 may be

removed and/ or inserted from the system as desired. On each insertion into the PCMCIA socket, the DSP-200/300 will be automatically reconfigured according to the command line options.

2.1.2 Command Line Options

The DSP-200/300 Client Driver accepts up to eight command line arguments from the user to determine the configuration of the DSP-200/300. If any arguments are provided, the Client Driver will attempt to configure any DSP-200/300s with the options specified in the order they are entered on the command line. Each argument must be enclosed in parenthesis and must be separated from other arguments by a **space** on the command line. Within each argument, any or all of the following parameters may be specified using a **comma (no spaces)** to separate each parameter:

- Baddress* specifies a the base I/O address of the DSP-200/300 in hexadecimal. This address must reside on an even 8-byte boundary. If this option is omitted, a base address will be assigned by Card and Socket Services.
- irq* specifies the interrupt level (IRQ) of the DSP-200/300 in decimal. *irq* must be one of the following values: 3, 4, 5, 7, 9, 10, 11, 12, 14, 15, or 0 if no IRQ is desired. If this option is omitted, an interrupt level will be assigned by Card and Socket Services.
- Ssocket* specifies which PCMCIA socket the DSP-200/300 must be inserted into for this configuration argument to be used. *socket* must be in the range 0 - 15. If this option is omitted, the configuration argument will apply to DSP-200/300s inserted into any socket.
- Odriver* specifies RS-422/485 output driver enable option for the DSP-200/300 port. The DSP-200/300's port may be configured for either full duplex or half duplex operation with this option. If this option is omitted, the default setting is the RS-422/485 port is configured for full duplex operation with the RS-422/485 output drivers always enabled. In half duplex mode, the RS-422/485 transmitter may be enabled and disabled via the RTS (request to send) or DTR (data terminal ready) signals. Both RTS and DTR are controlled through the Modem Control Register of the 16750. See the **Hardware Information** section for more information.

Option	Port Output Driver
o0	Always Enabled
o1	DTR Controlled
o2	RTS Controlled
o3	Auto-Toggle

Figure 3. DOS Client Output Enable Options.

H instructs the client driver to enable the RTS-CTS modem control handshake on the RS-422/485 port. When modem control handshaking is enabled, the 16C750 UART's RTS and CTS signals are connected to the RS-422/485 auxiliary channel. The auxiliary channel may then be used for handshaking between the DSP-200/300's port and a peripheral device. When modem control handshaking is disabled, the RTS and CTS signals from the 16C750 UART are looped back to each other. If this option is omitted, the default setting is RTS-CTS modem control handshake disabled. See the **Hardware Information** section for more information.

2.1.2.1 Example 1

```
DEVICE = C:\DSP-200\ DSP230CL.SYS
```

In example 1, no command line arguments are specified. The Client Driver will configure a DSP-200/300 inserted into any socket with a base address and IRQ assigned by Card and Socket Services. The DSP-200/300 RS-422/485 output drivers will always be enabled, and RTS-CTS modem control handshaking will be disabled.

2.1.2.2 Example 2

```
DEVICE = C:\DSP-200\ DSP230CL.SYS (b290,i11)
```

In example 2, a single command line argument is provided. The Client Driver will attempt to configure a DSP-200/300 inserted into any socket with a base address of 290H and IRQ 11. If address 290H or IRQ 11 is unavailable, the DSP-200/300 will not be configured. If the Client Driver can successfully configure the DSP-200/300 unit, the RS-422/485 output drivers will always be enabled, and RTS-CTS modem control handshaking will be disabled.

2.1.2.3 Example 3

```
DEVICE = C:\DSP-200\ DSP230CL.SYS(s0,b300,i5,o2)
```

In example 3, a single command line argument is provided. The Client Driver will attempt to configure a DSP-200/300 inserted into socket 0 with a base address of 300H and IRQ 5. If address 300H or IRQ 5 is unavailable, the DSP-200/300 will not be configured. In addition, if a DSP-200/300 is inserted into any other socket, it will not be configured. If the Client Driver can successfully configure the DSP-200/300, the RS-422/485 output drivers will be enabled and disabled via the RTS signal, and RTS-CTS modem control handshaking will be disabled.

2.1.2.4 Example 4

```
DEVICE = C:\DSP-200\DSP230CL.SYS(i5,h,b300)
```

In example 4, a single command line argument is provided. Because the parameter order is not significant, the Client Driver will attempt to configure a DSP-200/300 inserted into any socket with a base address of 300H and IRQ 5. If address 300H or IRQ 5 is unavailable, the DSP-200/300 will not be configured. If the Client Driver can successfully configure the DSP-200/300, the RS-422/485 output drivers will always be enabled, and RTS-CTS modem control handshaking will be enabled on the RS-422/485 port's auxiliary channel.

2.1.2.5 Example 5

```
DEVICE = C:\DSP-200\DSP230CL.SYS (b300,i5) (i10) ( )
```

In example 5, three command line arguments are provided. The Client Driver will first attempt to configure a DSP-200/300 inserted into any socket with a base address of 300H and IRQ 5. If address 300H or IRQ 5 is unavailable, the Client Driver will proceed to the second command line argument and attempt to configure the card with a base address assigned by Card and Socket Services and IRQ 10. If IRQ 10 is also unavailable, the Client Driver will proceed to the third command line argument and attempt to configure the DSP-200/300 with a base address and an IRQ assigned by Card and Socket Services. If the Client Driver can successfully configure the DSP-200/300, the RS-422/485 output drivers will always be enabled, and RTS-CTS modem control handshaking will be disabled.

2.1.2.6 Example 6

```
DEVICE = C:\DSP-200\DSP230CL.SYS (b300,i5) ( ) (i10)
```

In example 6, the three command line arguments of example 5 have been rearranged. The Client Driver will first attempt to configure a DSP-200/300 inserted into any socket with a base address of 300H and IRQ 5. If address 300H or IRQ 5 is unavailable, the Client Driver will proceed to the second command line argument and attempt to configure the card with a base address and IRQ assigned by Card and Socket Services. Since the second command line argument includes all available address and IRQ resources, the third command line argument will never be reached by the Client Driver. It is the user's responsibility to place the command line arguments in a logical order.

2.1.2.7 Example 7

DEVICE = C:\DSP-200\DSP230CL.SYS (s0,b300,i5) (s1,b340,i10)

The type of configuration shown in example 7 may be desirable in systems where more than one DSP-200/300 is to be installed. In this example, the Client Driver will attempt to configure a DSP-200/300 inserted into socket 0 with a base address of 300H and IRQ 5. If the DSP-200/300 is inserted into socket 1, the Client Driver will attempt to configure it with base address 340H and IRQ 10. This allows the user to force the DSP-200/300's address and IRQ settings to be socket specific which may simplify cable connections and software development. As in the previous examples, however, if the requested address or interrupt resources are not available, the DSP-200/300 will not be configured.

2.1.3 Common Problems

Generic Client Drivers:

Many Card and Socket Services packages include a generic client driver (or SuperClient) which configures standard I/O devices. If one of these generic client drivers is installed, it may configure the DSP-200/300 causing the DSP-200/300 client driver to fail installation. In these cases, the user should do one of the following:

1. Modify the operation of the generic client driver to disable the configuration of modem/serial port cards. Consult the Card and Socket Services documentation for availability and details of this feature.
2. Place the DSP-200/300 client driver before the generic client driver in the CONFIG.SYS.

Available Resources:

One function of the Card and Socket Services software is to track which system resources (memory addresses, I/O addresses, IRQs, etc.) are available for assignment to inserted PCMCIA cards. Sometimes, however, the Card Services software assumes or incorrectly determines that a particular resource is used when it is actually available. Most Card and Socket Services generate a resource table in a file (typically in the form of an .INI file) which the user can modify to adjust the available system resources. Consult the Card and Socket Services documentation for availability and details of this feature.

Multiple Configuration Attempts:

Some Card and Socket Services have a setting which aborts the configuration process after a single configuration failure (such as a request for an unavailable resource). The user should change this setting to allow for multiple configuration attempts. Consult the Card and Socket Services documentation for availability and details of this feature.

Older Versions of Card and Socket Services:

Some versions of Card and Socket Services dated before 1993 do not support general purpose I/O cards. If after careful installation of the Client Driver the DSP-200/300 does not configure or operate properly, an updated version of Card and Socket Services may be required. Card and Socket Services software is available from Quatech.

2.2 DSP-200/300 Enabler for DOS

For systems that are not operating PCMCIA Card and Socket Services software, the DSP-200/300 DOS Enabler may be used to enable and configure the adapter. This Enabler, DSP230EN.EXE, will operate on any DOS system using an Intel 82365SL or PCIC compatible PCMCIA host adapter including the Cirrus Logic CL-PD6710 /6720, the VLSI VL82C146, and the Vadem VG-365 among others.

IMPORTANT:

In order to use the DSP-200/300 Enabler for DOS, the system **MUST NOT** be configured with Card and Socket Services software. If a Card and Socket Services software is installed, the DSP-200/300 Enabler may interfere with its operation and with the device(s) it controls.

The DSP-200/300 Enabler does not support automatic configuration of adapters upon insertion, more commonly referred to as "Hot Swapping". This means the adapter must be installed in one of the system's PCMCIA sockets before executing DSP230EN.EXE. If more than one adapter is installed in a system, the Enabler must be executed separately for each adapter. Furthermore, DSP230EN.EXE should be executed to release the resources used by the adapter before it is removed from the PCMCIA socket. Since PCMCIA adapters do not retain their configuration after removal, any adapter that is removed from the system must be reconfigured with the Enabler after re-inserting it into a PCMCIA socket.

IMPORTANT:

The Enabler requires a region of high DOS memory when configuring a DSP-200/300. This region is 1000H bytes (4KB) long and by default begins at address D0000H (the default address may be changed using the "W" option). If a memory manager such as EMM386, QEMM, or 386Max is installed on the system, this region of DOS memory must be excluded from the memory manager's control. Consult the documentation provided with the memory manager software for instructions on how to exclude this memory region.

2.2.1 Command Line Options

To configure a DSP-200/300 in the system, the Enabler requires one command line argument from the user to determine the configuration of the card. This argument must be enclosed in parenthesis and within the argument, any or all of the following parameters may be specified using a **comma (no spaces)** to separate each parameter:

Ssocket specifies which PCMCIA socket the DSP-200/300 must be inserted into for this configuration argument to be used. *socket* must be in the range 0 - 15. This option is required if the 'R' option is not used.

Baddress specifies the base I/O address of the DSP-200/300 in hexadecimal. This address must reside on an even 8-byte boundary. This option is required if the 'R' option is not used.

Iirq specifies the interrupt level (IRQ) of the DSP-200/300 in decimal. *irq* must be one of the following values: 3, 4, 5, 7, 9, 10, 11, 12, 14, 15, or 0 if no IRQ is desired. This option is required if the 'R' option is not used.

Waddress specifies the base address of the memory window required to configure the DSP-200/300. Set *address* = D0 for a memory window at segment D000, *address* = D8 for a memory window at segment D800, etc. Valid settings for *address* are C8, CC, D0, D4, D8, and DC. If this option is omitted, a memory window at segment D000 will be used.

Odriver specifies RS-422/485 output driver enable option for the DSP-200/300. The DSP-200/300's port may be configured for either full duplex or half duplex operation with this option. If this option is omitted, the default setting is the RS-422/485 port is configured for full duplex operation with the RS-422/485 output drivers always enabled. In half duplex mode, the RS-422/485 transmitter may be enabled and disabled via the RTS (request to send) or DTR (data terminal ready) signals. Both RTS and DTR are controlled through the Modem Control Register of the 16750. See the **Hardware Information** section for more information.

Option	Output Driver
o0	Always Enabled
o1	DTR Controlled
o2	RTS Controlled
o3	Auto-toggle

Figure 4. DOS Enabler Output Enable Options.

H instructs the enabler to enable the RTS-CTS modem control handshake on the RS-422/485 port. When modem control handshaking is enabled, the 16C750 UART's RTS and CTS signals are connected to the RS-422/485 auxiliary channel. The auxiliary channel may then be used for handshaking between the DSP-200/300's RS-422/485 port and a peripheral device. When modem control handshaking is disabled, the RTS and CTS signals from the 16C750 UART are looped back to each other. If this option is omitted, the default setting is RTS-CTS modem control handshake disabled. See the **Hardware Information** section for more information .

Before removing a DSP-200/300 from its PCMCIA socket, the Enabler should be executed to free the system resources allocated when the card was installed. For this operation the Enabler provides an additional command line option:

R instructs the enabler to release the resources previously allocated to the DSP-200/300 . When the 'R' option is used, any settings specified by the 'B', 'T', 'O', and 'H' options are ignored.

2.2.1.1 Example 1

DSP230EN.EXE

In example 1, no command line argument is specified. The Enabler will report an error and display the proper usage of the command.

2.2.1.2 Example 2

DSP230EN.EXE (s0,b300,i5)

In example 2, the Enabler will configure the DSP-200/300 in socket 0 with a base address of 300H and IRQ 5 using a configuration memory window at segment D000. The DSP-200/300 unit's RS-422/485 output drivers will always be enabled, and RTS-CTS modem control handshaking will be disabled.

2.2.1.3 Example 3

DSP230EN.EXE (i10,h,b340,s1)

In example 3, the Enabler will configure the DSP-200/300 in socket 1 with a base address of 340H and IRQ 10 using a configuration memory window at segment D000. The DSP-200/300's RS-422/485 output drivers will always be enabled, and RTS-CTS modem control handshaking will be enabled on the RS-422/485 auxiliary channel.

2.2.1.4 Example 4

DSP230EN.EXE (s0,b300,i3,wd8)

In example 4, the Enabler will configure the DSP-200/300 in socket 0 with a base address of 300H and IRQ 3 using a configuration memory window at segment D800. The DSP-200/300's RS-422/485 output drivers will always be enabled, and RTS-CTS modem control handshaking will be disabled

2.2.1.5 Example 5

DSP230EN.EXE (o1,i5,b340,s1)

In example 2, the Enabler will configure the DSP-200/300 in socket 1 with a base address of 340H and IRQ 5 using a configuration memory window at segment D000. The DSP-200/300's RS-422/485 output drivers will be enabled and disabled via the DTR signal, and RTS-CTS modem control handshaking will be disabled

2.2.1.6 Example 6

DSP230EN.EXE (s0,b300,i5,r)

In example 6, the Enabler will release the configuration used by the DSP-200/300 in socket 0 using a configuration memory window at segment D000. The base address and IRQ parameters are ignored and may be omitted.

2.2.1.7 Example 7

DSP230EN.EXE (s1,r,wcc)

In example 7, the Enabler will release the configuration used by the DSP-200/300 in socket 1 using a configuration memory window at segment CC00.

2.2.2 Common Problems

Memory Range Exclusion:

The Enabler requires a region of high DOS memory when configuring a DSP-200/300. This region is 1000H bytes (4KB) long and by default begins at address D0000H (the default address may be changed using the "W" option). If a memory manager such as EMM386, QEMM, or 386Max is installed on the system, this region of DOS memory must be excluded from the memory manager's control. Consult the documentation provided with the memory manager software for instructions on how to exclude this memory region.

Furthermore, some systems use the high memory area for BIOS shadowing to improve overall system performance. In order for the Enabler to operate, any BIOS shadowing must be disabled in the address range specified for the configuration window. BIOS shadowing can usually be disabled through the system's CMOS setup utility.

Socket Numbers:

The Enabler requires the DSP-200/300's socket number to be specified on the command line and the DSP-200/300 must be inserted into the socket before the Enabler is invoked. Some vendors number their sockets from 1 to N while other vendors number their sockets from 0 to N-1. For the DSP-200/300 Enabler, the lowest socket number in the system is designated socket 0.

Card and Socket Services Software:

In order to use the DSP-200/300 Enabler for DOS, the system MUST NOT be configured with Card and Socket Services software. If a Card and Socket Services software is installed, the Enabler may interfere with its operation and with the device(s) it controls. For systems configured with Card and Socket Services, the DSP-200/300 Client Driver is the recommended method of configuration.

This page intentionally left blank.

3. Windows 95/98/Millennium (ME)

To allow easy configuration of the DSP-200/300, an Windows 95/98/ME "INF" configuration file has been written for the hardware. It supports the AUXIN/AUXOUT options and the RS-422/485 output driver enable options for full and half duplex operation.

3.1 Installing a DSP-200/300 Under Windows 95/98/ME

1. Insert the DSP-200/300 into any available PC Card socket.
2. The first time a new PC Card type is installed the **New Hardware Found** window opens. After this first installation Windows **95/98/ME** will automatically detect and configure the card. If the **New Hardware Found** window does not open, then skip to the next section, "DSP-200/300 Resource Settings".
3. The **New Hardware Found** window provides several options to configure the DSP-200/300 card. Click the "**Search for the best driver for your device**" option button. Click "NEXT" to continue.
4. An "**Install from Disk**" dialog box should appear. Insert the Quatech COM CD file, select the correct drive letter and path, and click "OK". Windows 95/98/ME will browse the path for the aforementioned files.
5. During the installation process, it may be required to supply the computer with the Windows 95/98/ME CD or installation CDs. Insert the CD and click "OK".

The DSP-200/300 PC Card should now be configured. With the default configuration, the DSP-200/300's interrupt status register will be enabled, the 16C750 UART's scratchpad register will be disabled, the RS-422/485 output drivers will always be enabled, and RTS-CTS modem control handshaking will be enabled. In the future, Windows 95/98/ME will automatically recognize and configure the DSP-200/300 in this default configuration.

3.2 DSP-200/300 Resource Settings in Windows 95/98/ME

Windows **95/98/ME** maintains a registry of all known hardware installed within the computer. Inside this hardware registry Windows **95/98/ME** keeps track of all the computer's resources, such as base I/O addresses, IRQ levels, and DMA channels. In the case of a **PC Card (PCMCIA)** type board, Windows **95/98/ME** configures the new hardware using free resources it finds within the hardware registry, and updates the registry automatically.

To view and/or edit hardware devices in Windows **95/98/ME** use the system **Device Manager**. To access Device Manager double click the **System** icon in the Windows **95/98/ME** control panel, or click the **My Computer** icon on the Windows **95/98/ME** desktop with the right mouse button and select **Properties** from the pull down menu. Consult Windows **95/98/ME** on-line help for details on the use of the **Device Manager**.

3.2.1 Viewing Resource Settings with Device Manager

1. Start the Windows **95/98/ME Device Manager**.
2. Double click on the hardware class **Quatech Comm Adapters** to list hardware devices in the class.
3. The DSP-200/300 “parent device” belongs to this hardware class. The device name for the DSP-200/300 is **Quatech DSP-200/300: Dual RS-422/RS-485 Serial Port PC Card**.
4. Open the **Properties** dialog for the DSP-200/300 device, then click the **Resources** tab to view the Input/Output Range and Interrupt Request resource allocations.
5. Double click the hardware class **Ports (Com and LPT)**. Each **Quatech Communications Port** listed in this class is a “child device” of the DSP-200/300 “parent device.”
6. Open the **Properties** dialog for a COM port, then click the **Resources** tab to view the Input/Output Range and Interrupt Request resource allocations. These will match those of the “parent device.”
7. Record the COM Port device names (COM1, COM2, etc.) for the DSP-200/300. These names are required by Windows **95/98/ME** applications when accessing particular ports.

3.2.2 Changing Resource Settings with Device Manager

1. Start the Windows **95/98/ME Device Manager**.
 2. Double click on the hardware class **Quatech Comm Adapters** to list hardware devices in the class.
 3. The DSP-200/300 “parent device” belongs to this hardware class. The device name for the DSP-200/300 is **Quatech DSP-200/300: Dual RS-422/RS-485 Serial Port PC Card**.
 4. Open the **Properties** dialog for the DSP-200/300 device, then click the **Resources** tab to view the Input/Output Range and Interrupt Request resource allocations.
 5. Several predefined **Basic Configurations** have been included for the DSP-200/300 (see Figure 5. DSP-200/300 Basic Configuration Table). The Basic Configurations provide many combinations of the operating modes and options listed below. See the **Hardware Information** section of this manual for complete descriptions.
- RS-422/485 output drivers enable option: The DSP-200/300’s ports may be configured for either full duplex or half duplex operation with this option. The default setting is the RS-422/485 ports are configured for full duplex operation with the RS-422/485 output drivers always enabled. In half duplex mode, the RS-422/485

transmitter may be enabled and disabled via the RTS (request to send) or DTR (data terminal ready) signals, or set to enable only when data is being transmitted (auto-toggle). Both RTS and DTR are controlled through the Modem Control Register of the 16750.

When the **Use Automatic Settings** check box is enabled Windows 95/98/ME will attempt to configure the DSP-200/300 in the order listed in the Basic Configurations table.

Basic Configuration	Auxiliary Connections**	I/O Range***	RS-422/485 Output Drivers	Clock Speed	Scratch Pad/ISR
0000	Loopback	Any	Always Enabled	Normal	ISR
0001	Loopback	Any	Always Enabled	8x	ISR
0002	Loopback	Any	Auto Toggle	Normal	ISR
0003	Loopback	Any	RTS Controlled	Normal	ISR
0004	Loopback	Any	DTR Controlled	Normal	ISR
0005	Handshaking	Any	Always Enabled	Normal	ISR
0006	Clocking	Any	Always Enabled	Normal	ISR
0007	Loopback	Any	Auto Toggle	8x	ISR
0008	Loopback	Any	RTS Controlled	8x	ISR
0009	Loopback	Any	DTR Controlled	8x	ISR
000A	Handshaking	Any	Always Enabled	8x	ISR
000B	Clocking	Any	Always Enabled	8x	ISR
000C	Handshaking	Any	Auto Toggle	Normal	ISR
000D	Clocking	Any	Auto Toggle	Normal	ISR
000E	Handshaking	Any	RTS Controlled	Normal	ISR
000F	Clocking	Any	RTS Controlled	Normal	ISR
0010	Handshaking	Any	DTR Controlled	Normal	ISR
0011	Clocking	Any	DTR Controlled	Normal	ISR
0012	Handshaking	Any	Auto Toggle	8x	ISR
0013	Clocking	Any	Auto Toggle	8x	ISR
0014	Handshaking	Any	RTS Controlled	8x	ISR
0015	Clocking	Any	RTS Controlled	8x	ISR
0016	Handshaking	Any	DTR Controlled	8x	ISR
0017	Clocking	Any	DTR Controlled	8x	ISR
0018	Loopback	Any	Always Enabled	Normal	Scratch Pad
0019	Loopback	Any	Always Enabled	8x	Scratch Pad
001A	Loopback	Any	Auto Toggle	Normal	Scratch Pad
001B	Loopback	Any	RTS Controlled	Normal	Scratch Pad
001C	Loopback	Any	DTR Controlled	Normal	Scratch Pad
001D	Handshaking	Any	Always Enabled	Normal	Scratch Pad
001E	Clocking	Any	Always Enabled	Normal	Scratch Pad
001F	Loopback	Any	Auto Toggle	8x	Scratch Pad
0020	Loopback	Any	RTS Controlled	8x	Scratch Pad
0021	Loopback	Any	DTR Controlled	8x	Scratch Pad
0022	Handshaking	Any	Always Enabled	8x	Scratch Pad
0023	Clocking	Any	Always Enabled	8x	Scratch Pad
0024	Handshaking	Any	Auto Toggle	Normal	Scratch Pad
0025	Clocking	Any	Auto Toggle	Normal	Scratch Pad
0026	Handshaking	Any	RTS Controlled	Normal	Scratch Pad
0027	Clocking	Any	RTS Controlled	Normal	Scratch Pad
0028	Handshaking	Any	DTR Controlled	Normal	Scratch Pad
0029	Clocking	Any	DTR Controlled	Normal	Scratch Pad
002A	Handshaking	Any	Auto Toggle	8x	Scratch Pad
002B	Clocking	Any	Auto Toggle	8x	Scratch Pad
002C	Handshaking	Any	RTS Controlled	8x	Scratch Pad
002D	Clocking	Any	RTS Controlled	8x	Scratch Pad
002E	Handshaking	Any	DTR Controlled	8x	Scratch Pad
002F	Clocking	Any	DTR Controlled	8x	Scratch Pad

** Handshaking indicates RTS routed to AUXOUT, AUXIN routed to CTS, and TCLK routed to RCLK.
Loopback indicates RTS routed to CTS, AUXIN routed to AUXOUT, and TCLK routed to RCLK.
Clocking indicates RTS routed to CTS, AUXIN routed to RCLK, and TCLK routed to AUXOUT.

*** Any indicates variable value; this value may or may not be user selectable depending on platform.

6. Select a **Basic Configurations** that displays "No conflicts" in the bottom display region titled **Conflicting Device List** from the drop down list. Some applications may not be able to access ports higher than COM4. To use the DSP-200/300 PCMCIA serial ports with these applications you might be forced to remove other serial communications devices from your system
7. To modify the **Interrupt Request** setting click the resource name and click the **Change Setting** button. An Edit Resource window will open up. Inside this window click on the up/down arrows to the right of the Interrupt Request value. This scrolls you through all of the allowable resources for your hardware. Pay attention to the conflict information at the bottom of the window. Do not select a value that causes a conflict with any other installed hardware.
8. If any changes have been made to the DSP-200/300's configuration the card will automatically be reconfigured to the new resources specified. Any time a PCMCIA card of this type is inserted Windows 95/98/ME will attempt to configure the card at these resource settings. Click the **Use Automatic Settings** box to reset this card type for automatic configuration.

3.3 Frequently Asked Questions

Basic Configuration List Not Available:

A problem noted on some systems is after a basic configuration has been manually selected the basic configurations list for the DSP-200/300 is no longer available. The solution to this problem is to check the "Use Automatic Settings" box and allow Windows 95/98/ME to reconfigure the DSP-200/300 card. The basic configurations list should once again be visible.

Base I/O Address Resource Modification Not Allowed:

The DSP-200/300 is configured to allow only a fixed number of base I/O addresses. To change the I/O address resources for the DSP-200/300 select another "Basic Configuration". Refer to the Basic Configurations table for a list of the available I/O address resources for the DSP-200/300

This page intentionally left blank.

4 Windows 2000

To allow easy configuration of the DSP-200/300, an Windows **2000 "INF"** configuration file has been written for the hardware. This configuration file supports the DSP-200/300 in both addressing modes: block mode and "com" mode. Additionally, the RTS-CTS modem control handshake option and the RS-422/485 output driver enable option for full and half duplex operation is supported.

4.1 Installing a DSP-200/300 Under Windows 2000.

1. Insert the Quatech COM CD into an available CD-ROM.
2. Insert the DSP-200/300 into any available PC Card socket.
3. You will be prompted to search for the correct driver. Choose the drive where the quatech COM CD is located and select "Browse" from the 'Files Needed' window.

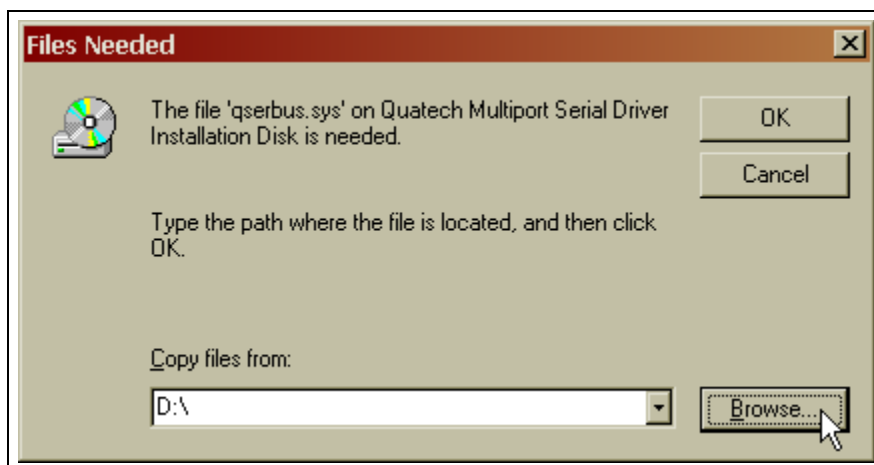

4. Double click 'Serial Port Adapters'

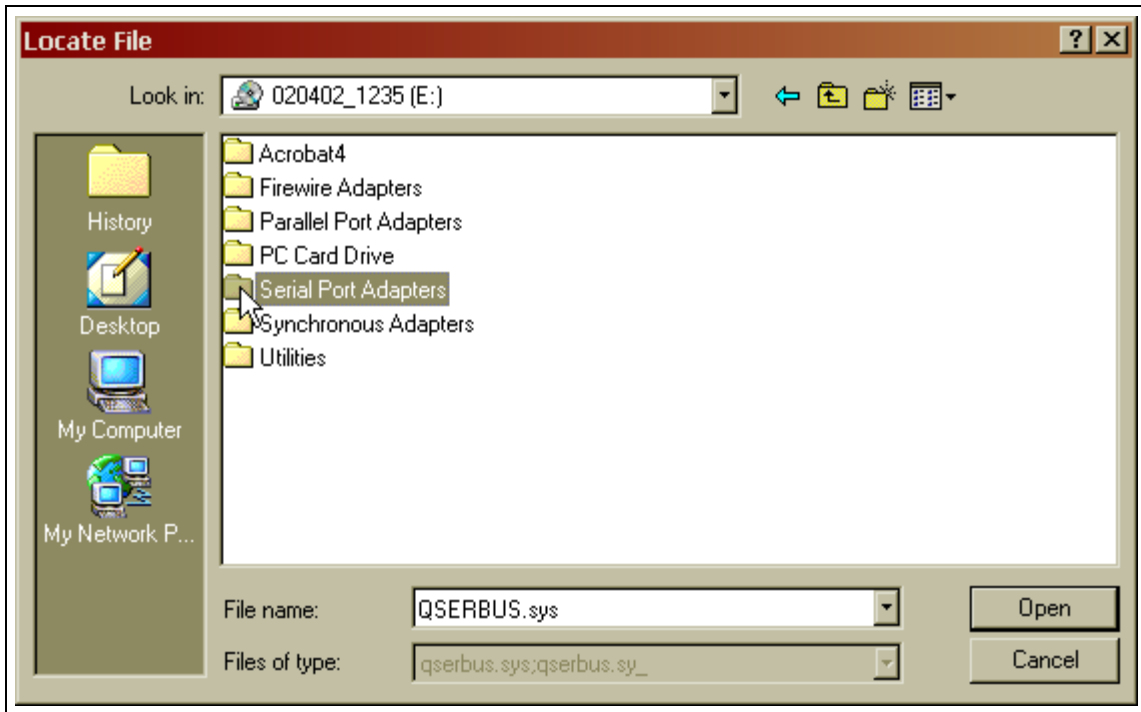

5. Double click 'Drivers'

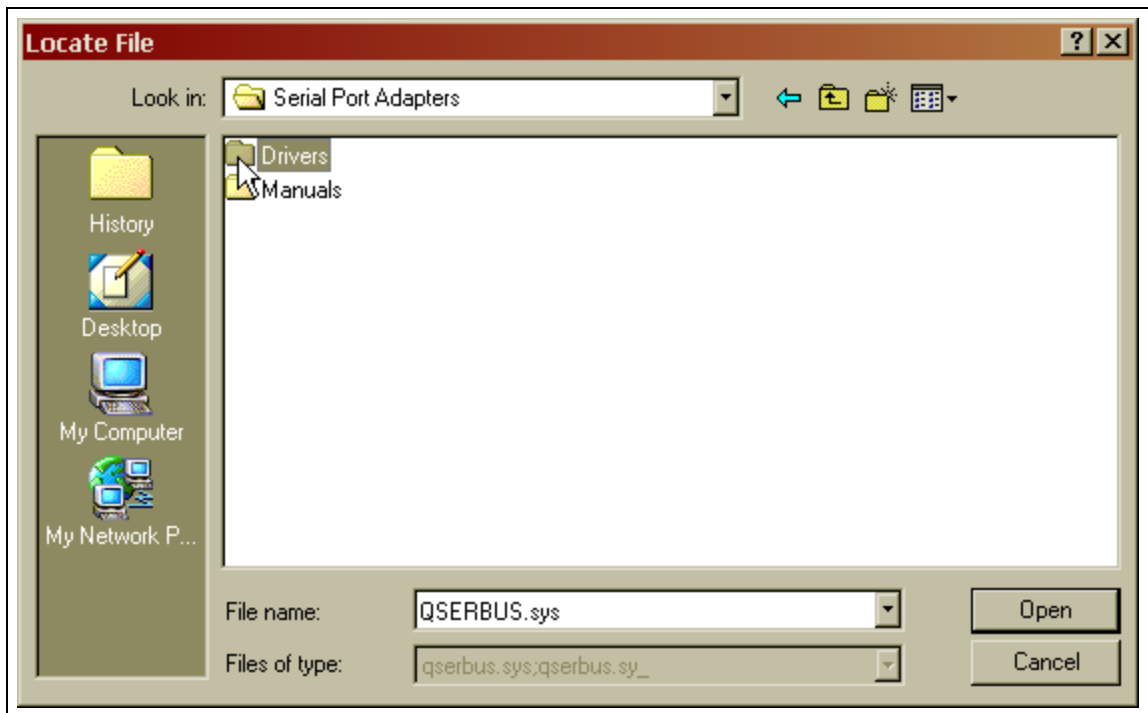

6. Double click on 'Windows 2000, XP, for PCI, PCMCIA, ISA'

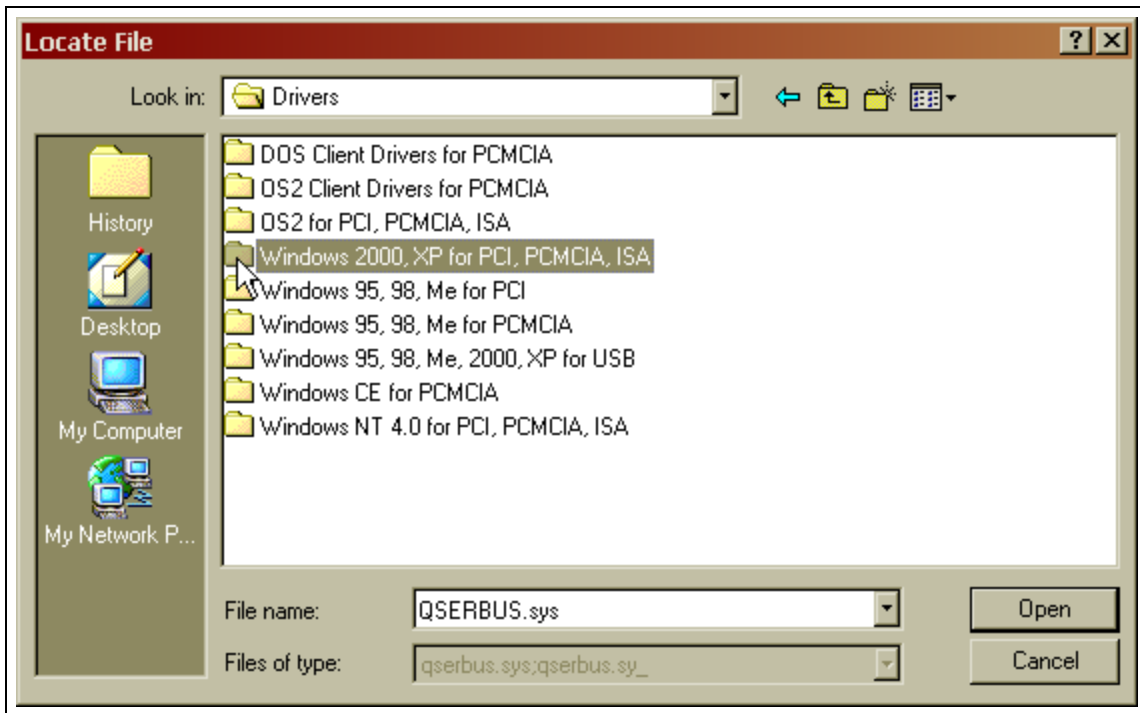

7. Click on 'qserbrd' and select open.

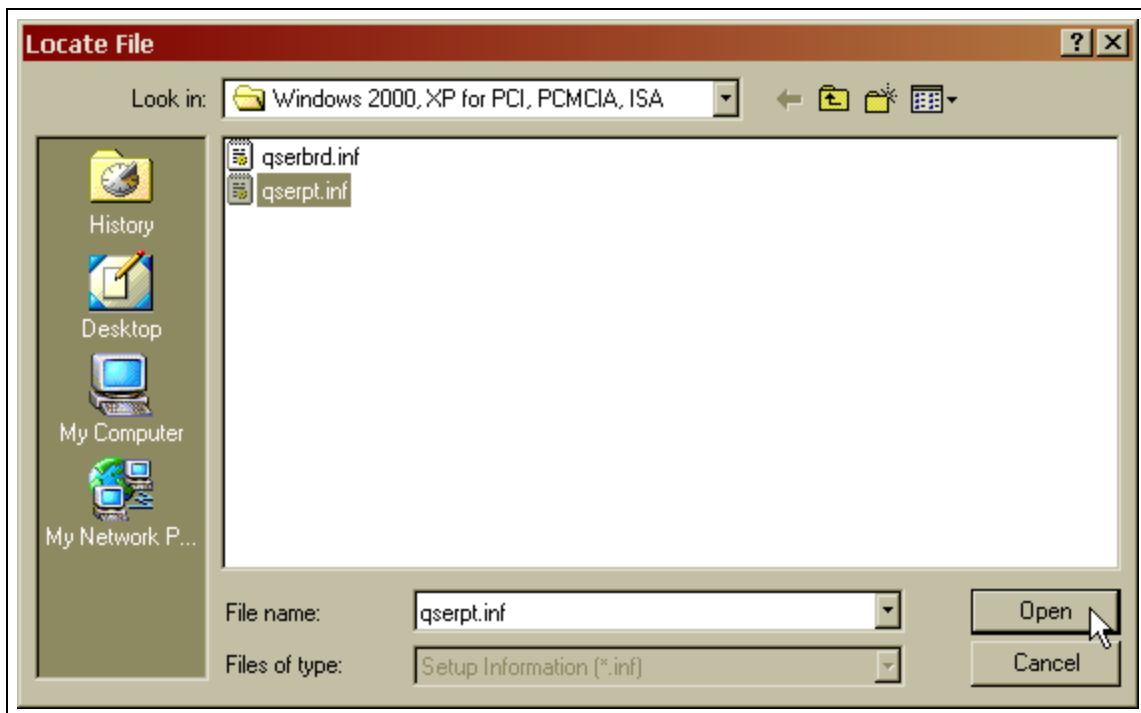

8. Select 'OK' at the 'Files Needed' window

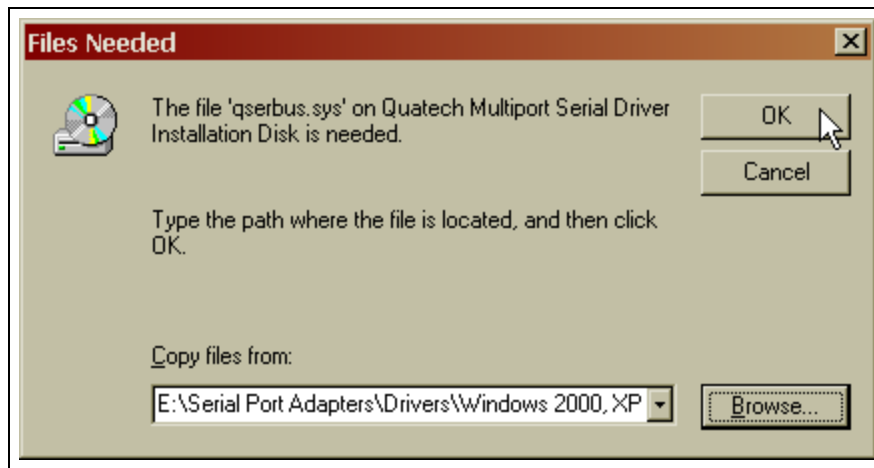

9. The same process as above in steps 1-9 will apply for the next file 'qserpt.inf'. In step 7 be sure to choose 'qserpt.inf' and select 'Open'.

4.2 DSP-200/300 Resource Settings in Windows 2000

Windows 2000 maintains a registry of all known hardware installed within the computer. Inside this hardware registry Windows 2000 keeps track of all the computer's resources, such as base I/O addresses, IRQ levels, and DMA channels. In the case of a **PC Card (PCMCIA)** type board, Windows 2000 configures the new hardware using free resources it finds within the hardware registry, and updates the registry automatically.

To view and / or edit hardware devices in Windows 2000 use the system **Device Manager**.

To access Device Manager double click the **System** icon in the Windows 2000 control panel, or click the **My Computer** icon on the Windows 2000 desktop with the right mouse button and select **Properties** from the pull down menu. Click on the **Hardware** tab then click on the **Device Manager**. Consult Windows 2000 on-line help for details on the use of the **Device Manager**

Windows 2000 handles the DSP-200/300 as a "parent/child device".

- The DSP-200/300 is the "parent device" and is listed under the hardware class **Quatech Multiport Serial Devices** in the device manager
- Each serial port is a "child device" of the "parent device" DSP-200/300 (Quatech PCMCIA Serial Port). There are 2 child COM ports for the DSP-200/300 (Quatech PCMCIA Serial Port) which are listed under the hardware class **Ports (Com & LPT)**.

4.2.1 Viewing Resource Settings with Device Manager

1. Start the Windows 2000 **Device Manager**.
2. Double click on the hardware class **Quatech Multiport Serial Devices** to list hardware devices in the class.

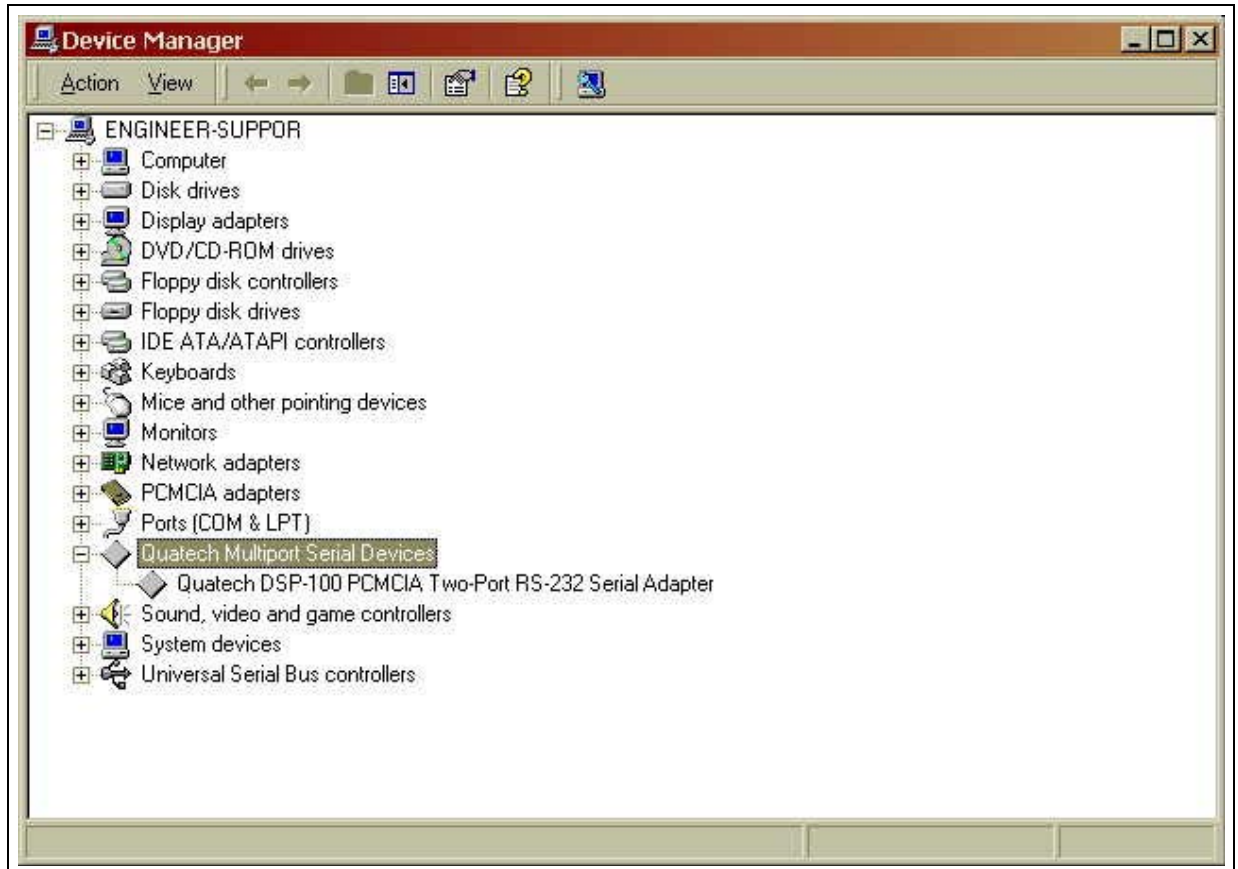

3. The DSP-200/300 “parent device” belongs to this hardware class. The device name for the DSP-200/300 is **Quatech DSP-200/300 PCMCIA Two-Port RS-422/RS-485 Serial Adapter**. (Figure 10)
4. Open the **Properties** dialog for the DSP-200/300 device, then click the **Resources** tab to view the Input/Output Range and Interrupt Request resource allocations. Examine and remember the Input/Output Range, then close the properties window.
5. Double click the hardware class **Ports (Com and LPT)**. Each **Quatech PCMCIA Serial Port** listed in this class is a “child device” of the DSP-200/300 “parent device.”

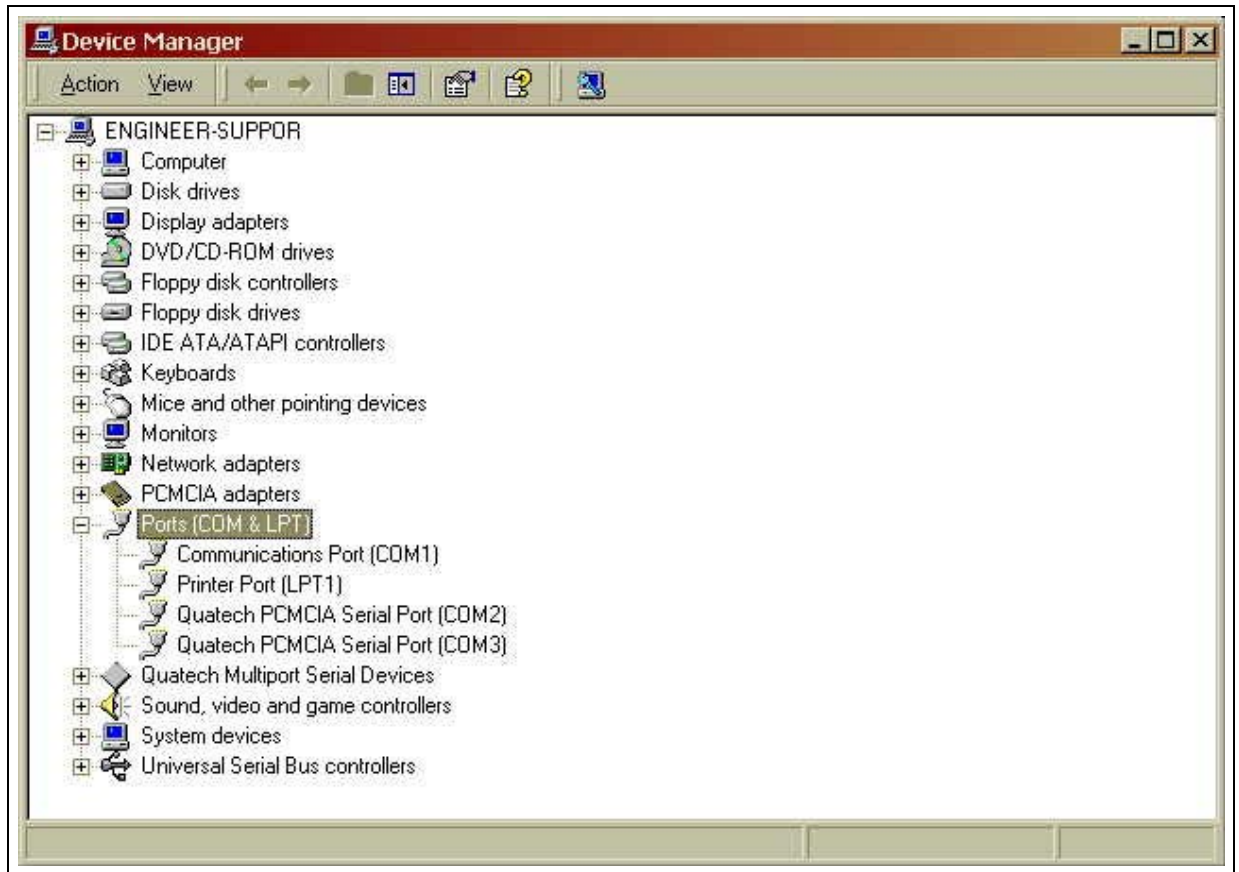

6. Use the COM Port device names (COM5, COM6, etc.) to access any of the particular serial ports on the DSP-200/300. These names are required by **Windows 2000** applications when accessing particular ports.

4.2.2 Changing Resource Settings with Device Manager

1. Start the Windows 2000 **Device Manager**.

To access Device Manager double click the **System** icon in the Windows 2000 control panel, or click the **My Computer** icon on the Windows 2000 desktop with the right mouse button and select **Properties** from the pull down menu. Click on the **Hardware** tab then click on the **Device Manager**. Consult Windows 2000 on-line help for details on the use of the **Device Manager**

2. Double click on the hardware class **Quatech Multiport Serial Devices** to list hardware devices in the class. (Figure 10)
3. The DSP-200/300 “parent device” belongs to this hardware class. The device name for the DSP-200/300 is **Quatech DSP-200/300 PCMCIA Two-Port RS-422/RS-485 Serial Adapter**. (Figure 10)

4. Open the **Properties** dialog for the DSP-200/300 device (Figure 12), then click the **Advanced** tab to view the clock rate settings.

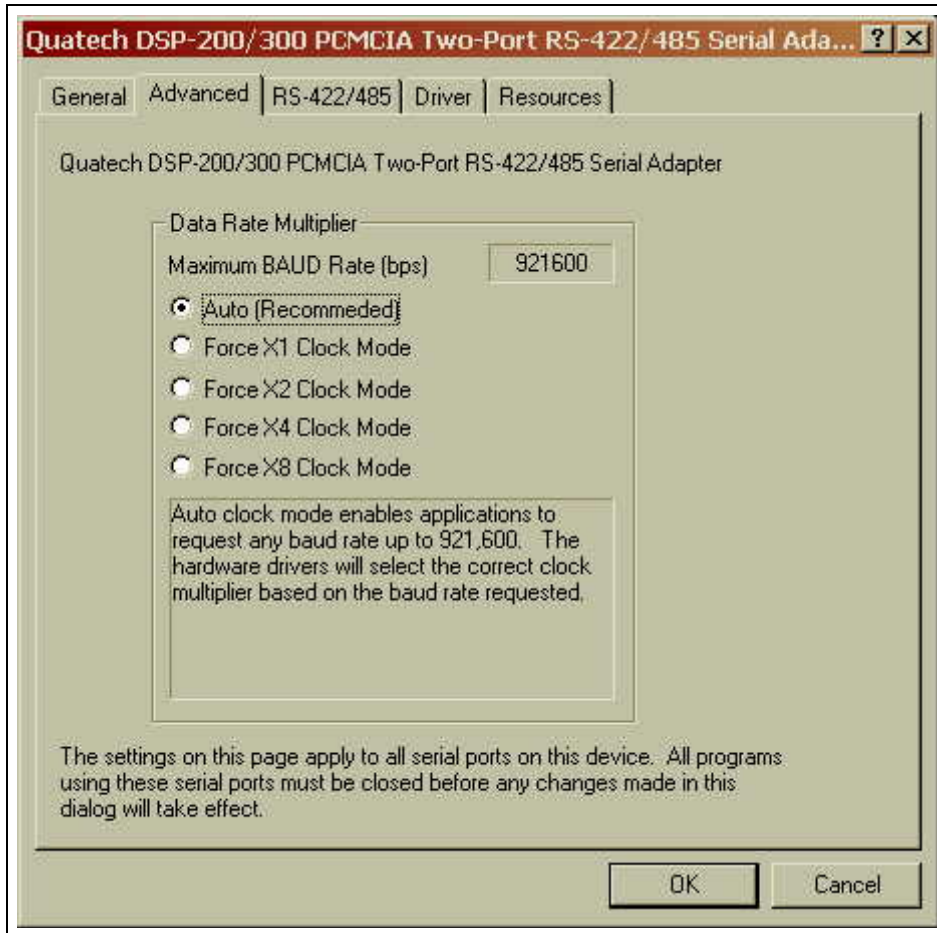

Data Rate Multiplier		
Clock Mode	Max bps	Description
Auto	921,600	Auto clock mode enables applications to request any baud rate up to 921,600. The hardware drivers will select the correct clock multiplier based on the baud rate requested
X1	115,200	The X1 clock mode mimics a standard COM port. The hardware drivers lock the clock to the standard rate. The port will run at the baud rate requested by the application.
X2	230,400	The X2 clock mode locks the ports hardware clock at double the standard rate. The baud rate the port runs at will always be double the rate requested by the applications. This mode is useful for legacy applicattions which cannot request baud rates over 115,200
X4	460,800	The X4 clock mode locks the ports hardware clock at four times the standard rate. The baud rate the port runs at will always be four times the rate requested by the application. This mode is useful for legacy applications which cannot request baud rates over 115.200.
X8	921,600	The X8 clock mode locks the ports hardware clock at eight times the standard rate. The baud rate the port runs at will always be eight times the rate requested by the application. This mode is useful for legacy applications which cannot request baud rates over 115.200.

5. Click the **RS-422/485** tab to view the transmitter enable and connector pinout option.

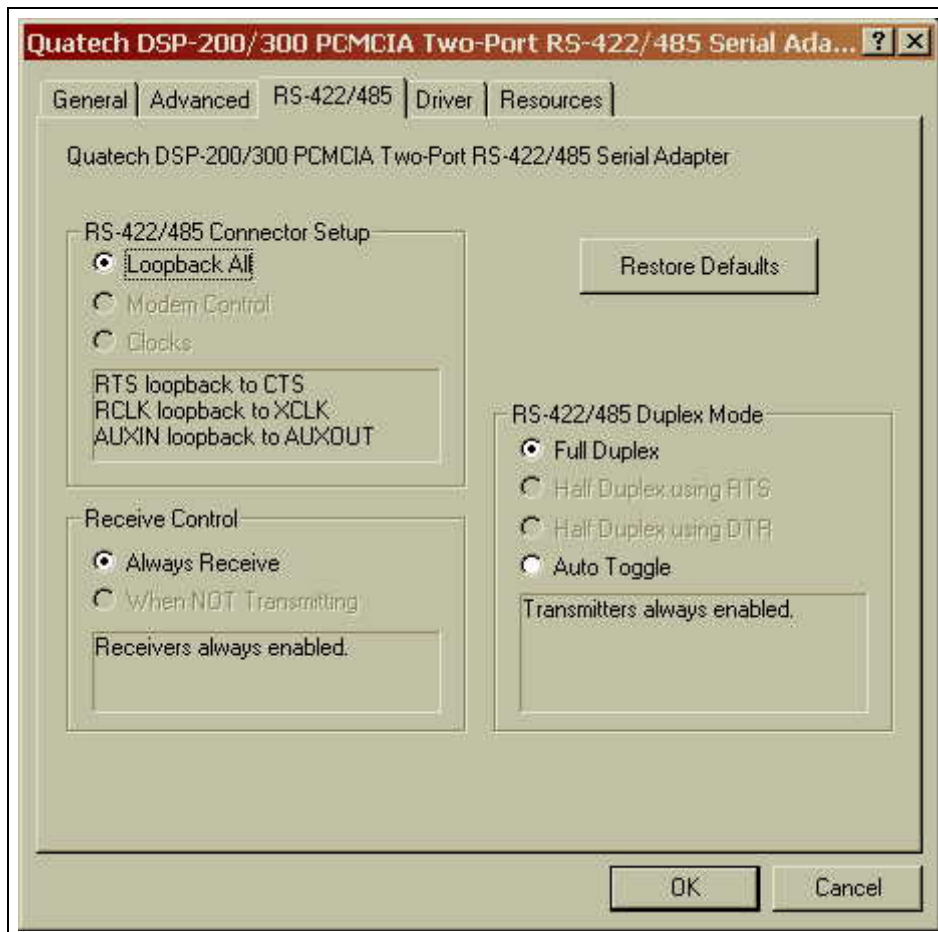

RS-422/485 Connector Setup	
Loopback All	RTS routed to CTS, AUXIN routed to AUXOUT, and TCLK routed to RCLK. Used when external handshaking or clocking signals are not available.
Modem Control	RTS routed to AUXOUT, AUXIN routed to CTS, and TCLK routed to RCLK. Used when RTS/CTS handshaking is required.
Clocks	RTS routed to CTS, AUXIN routed to RCLK, and TCLK routed to AUXOUT. Used to connect ports transmitting at different baud rates. In order to function, all ports must have and use this feature.
Receive Control	
Always Receive	Receivers are always enabled. In a Half Duplex mode, you will receive what you transmit (sometimes called echo).
When NOT Transmitting	Receivers are only enabled when not transmitting. In a Half Duplex mode, you will not receive what you transmit.
RS-422/485 Duplex Mode	
Full Duplex	Transmitters and receivers are always enabled; ports can send and receive simultaneously. Used in four-wire communication.
Half Duplex using RTS	RTS is set to enable the transmitters. Used in two-wire communication.
Half Duplex using DTR	DTR is set to enable the transmitters. Used in two-wire communication.
Auto Toggle	Hardware automatically enables the transmitters when transmitting. Transmitters will turn off three bit-times after the last stop bit of the last character, regardless of baud rate. Used in two-wire communication.

- Click the **Resources** tab to view the Input/Output Range and Interrupt Request resource allocations. If options that are not available on the preceding pages are required, a different basic configuration will have to be selected. To do this, de-select the **Use Automatic Settings** box and choose the basic configuration that corresponds to the set of options required.

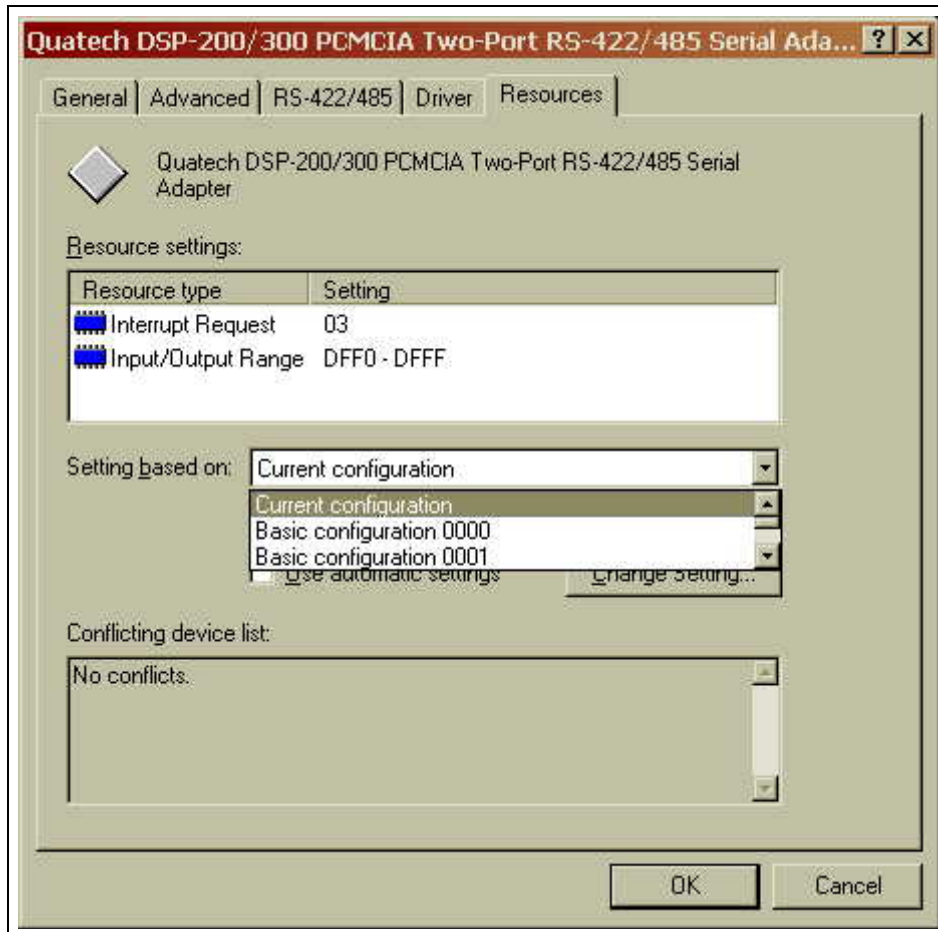

Basic Configuration	Auxiliary Connections**	I/O Range***	RS-422/485 Output Drivers	Clock Speed	Scratch Pad/ISR
0000	Loopback	Any	Always Enabled	Normal	ISR
0001	Loopback	Any	Always Enabled	8x	ISR
0002	Loopback	Any	Auto Toggle	Normal	ISR
0003	Loopback	Any	RTS Controlled	Normal	ISR
0004	Loopback	Any	DTR Controlled	Normal	ISR
0005	Handshaking	Any	Always Enabled	Normal	ISR
0006	Clocking	Any	Always Enabled	Normal	ISR
0007	Loopback	Any	Auto Toggle	8x	ISR
0008	Loopback	Any	RTS Controlled	8x	ISR
0009	Loopback	Any	DTR Controlled	8x	ISR
0010	Handshaking	Any	Always Enabled	8x	ISR
0011	Clocking	Any	Always Enabled	8x	ISR
0012	Handshaking	Any	Auto Toggle	Normal	ISR
0013	Clocking	Any	Auto Toggle	Normal	ISR
0014	Handshaking	Any	RTS Controlled	Normal	ISR
0015	Clocking	Any	RTS Controlled	Normal	ISR
0016	Handshaking	Any	DTR Controlled	Normal	ISR
0017	Clocking	Any	DTR Controlled	Normal	ISR
0018	Handshaking	Any	Auto Toggle	8x	ISR
0019	Clocking	Any	Auto Toggle	8x	ISR

0020	Handshaking	Any	RTS Controlled	8x	ISR
0021	Clocking	Any	RTS Controlled	8x	ISR
0022	Handshaking	Any	DTR Controlled	8x	ISR
0023	Clocking	Any	DTR Controlled	8x	ISR
0024	Loopback	Any	Always Enabled	Normal	Scratch Pad
0025	Loopback	Any	Always Enabled	8x	Scratch Pad
0026	Loopback	Any	Auto Toggle	Normal	Scratch Pad
0027	Loopback	Any	RTS Controlled	Normal	Scratch Pad
0028	Loopback	Any	DTR Controlled	Normal	Scratch Pad
0029	Handshaking	Any	Always Enabled	Normal	Scratch Pad
0030	Clocking	Any	Always Enabled	Normal	Scratch Pad
0031	Loopback	Any	Auto Toggle	8x	Scratch Pad
0032	Loopback	Any	RTS Controlled	8x	Scratch Pad
0033	Loopback	Any	DTR Controlled	8x	Scratch Pad
0034	Handshaking	Any	Always Enabled	8x	Scratch Pad
0035	Clocking	Any	Always Enabled	8x	Scratch Pad
0036	Handshaking	Any	Auto Toggle	Normal	Scratch Pad
0037	Clocking	Any	Auto Toggle	Normal	Scratch Pad
0038	Handshaking	Any	RTS Controlled	Normal	Scratch Pad
0039	Clocking	Any	RTS Controlled	Normal	Scratch Pad
0040	Handshaking	Any	DTR Controlled	Normal	Scratch Pad
0041	Clocking	Any	DTR Controlled	Normal	Scratch Pad
0042	Handshaking	Any	Auto Toggle	8x	Scratch Pad
0043	Clocking	Any	Auto Toggle	8x	Scratch Pad
0044	Handshaking	Any	RTS Controlled	8x	Scratch Pad
0045	Clocking	Any	RTS Controlled	8x	Scratch Pad
0046	Handshaking	Any	DTR Controlled	8x	Scratch Pad
0047	Clocking	Any	DTR Controlled	8x	Scratch Pad
0048	Loopback	Memory Mapped	Always Enabled	1x	Scratch Pad

** Handshaking indicates RTS routed to AUXOUT, AUXIN routed to CTS, and TCLK routed to RCLK. Loopback indicates RTS routed to CTS, AUXIN routed to AUXOUT, and TCLK routed to RCLK. Clocking indicates RTS routed to CTS, AUXIN routed to RCLK, and TCLK routed to AUXOUT.

*** Any indicates variable value; this value may or may not be user selectable depending on platform.

7. Select a **Basic Configuration** that displays "No conflicts" in the bottom display region titled **Conflicting Device List** from the drop down list.
8. Windows 2000 should have chosen an available **Interrupt Request** setting automatically when the I/O address range was configured by a Basic Configuration selection. This default **Interrupt Request** setting should not need changed as long as "No conflicts" is displayed in the bottom display region titled **Conflicting Device List**. If you are satisfied with Windows 2000 selection then skip the next step.

9. To modify the **Interrupt Request** setting click the resource name and click the **Change Setting** button. An Edit Resource window will open up. Inside this window click on the up/down arrows to the right of the Interrupt Request value. This scrolls you through all of the allowable resources for your hardware. Pay attention to the conflict information at the bottom of the window. Do not select a value that causes a conflict with any other installed hardware.
10. If any changes have been made to the DSP-200/300's configuration the card will automatically be reconfigured to the new resources specified. Any time a PCMCIA card of this type is inserted Windows 2000 will attempt to configure the card at these resource settings. Click the **Use Automatic Settings** box to reset this card type for automatic configuration

This page intentionally left blank.

5 Windows NT

5.1 Installing DSP-200/300

To allow easy configuration of the DSP-200/300 the Quatech Device Manager for Windows NT has been written for the hardware. This configuration utility supports the DSP-200/300 only in block addressing mode.

To begin the installation, open Windows Explorer and search for the 'Setup.exe' command to install the Quatech Device Manager. <See following Windows Explorer figure.> (D:\Serial Port Adapters\Drivers\Windows NT 4.0 for PCI, PCMCIA,ISA). Once the installation is complete an icon will be placed on the desktop.

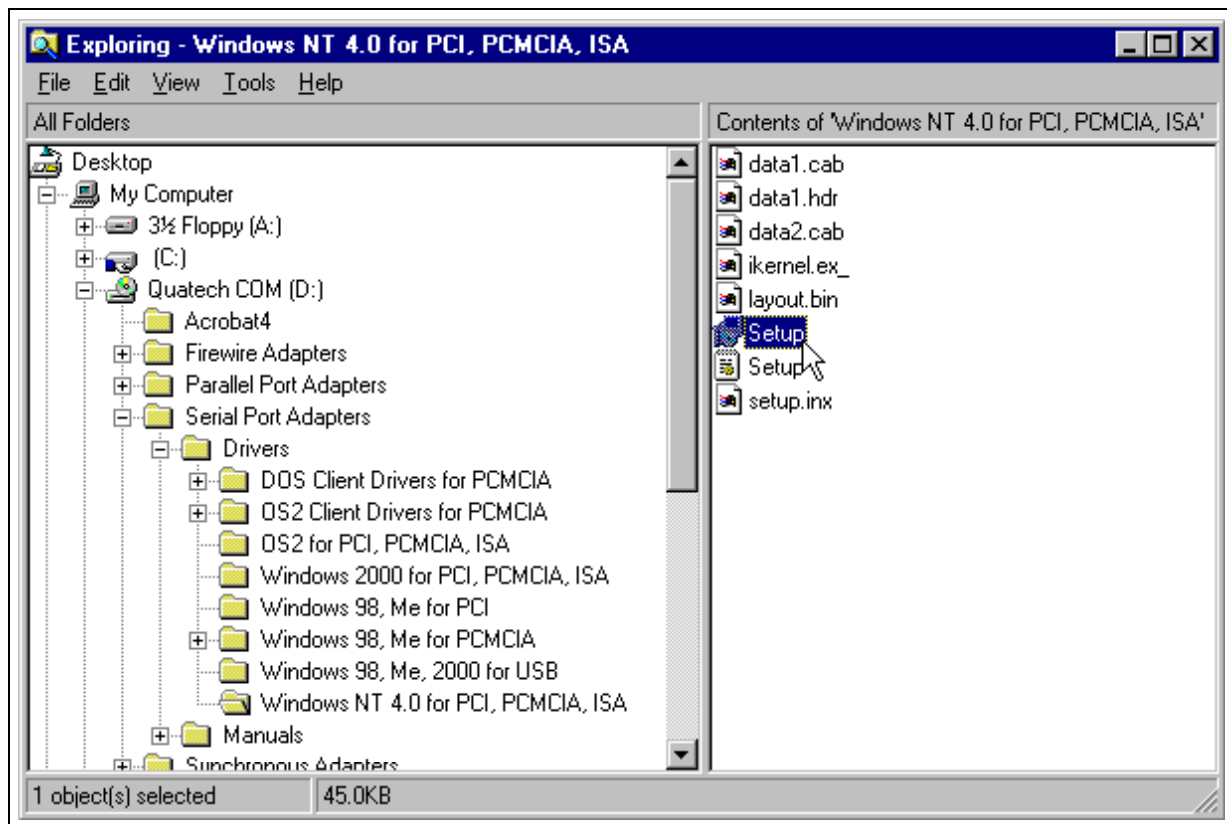

Windows NT Explorer

1. Locate and double click the Quatech Device Manager icon on the desktop

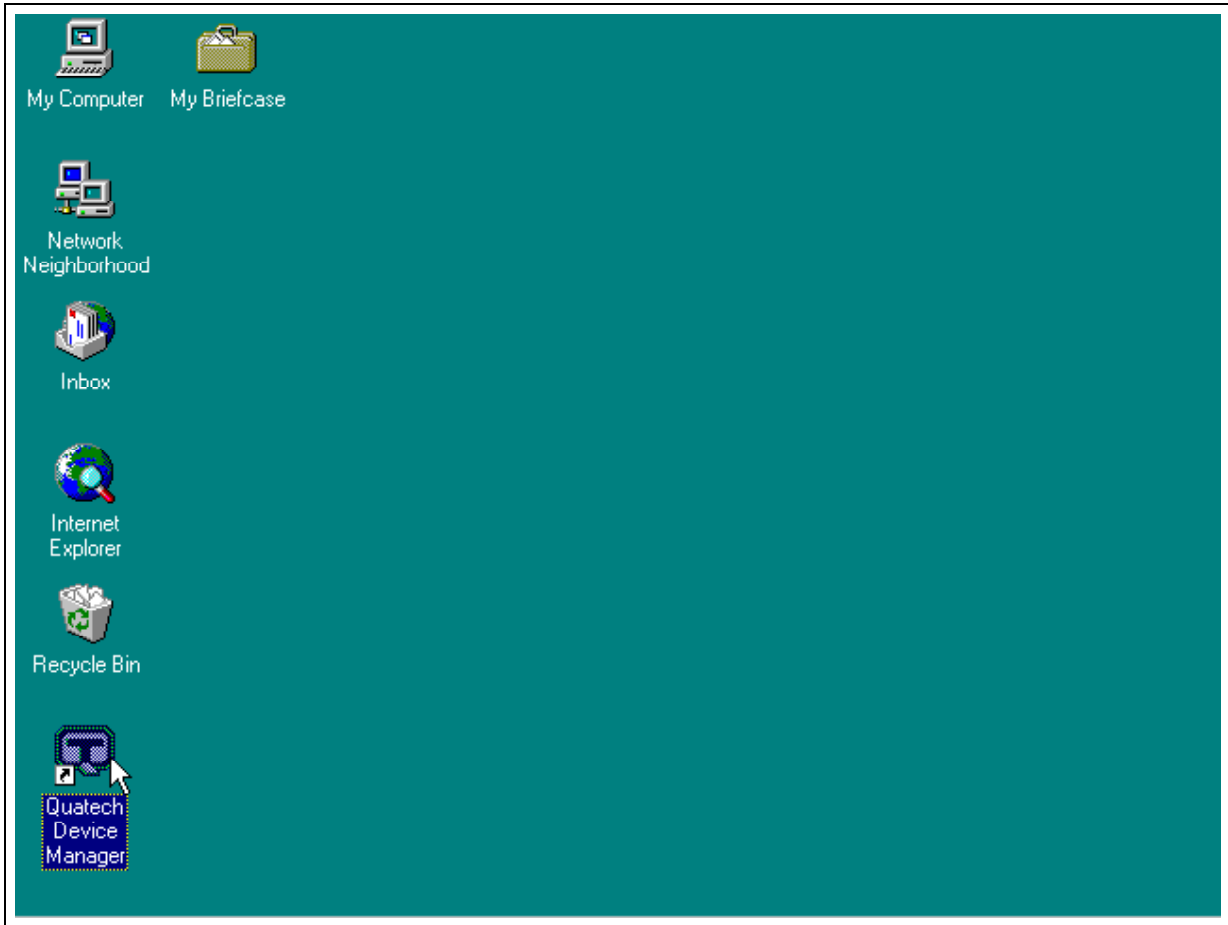

Device Manager Icon on Desktop

2. Click the 'Add' button at the bottom of the Quatech Device Manager Window



3. Follow the steps for the 'Add Quatech Hardware Wizard'.

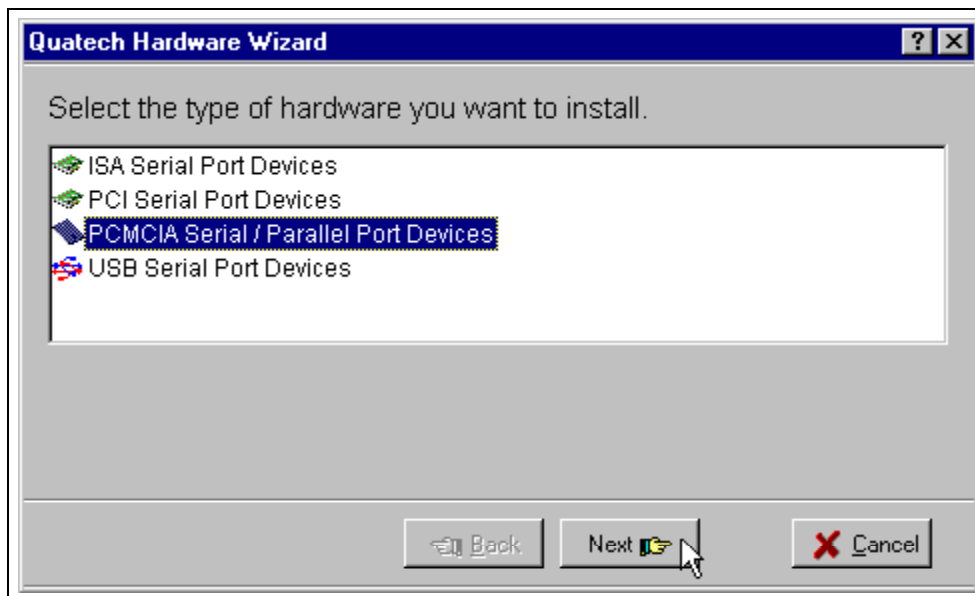

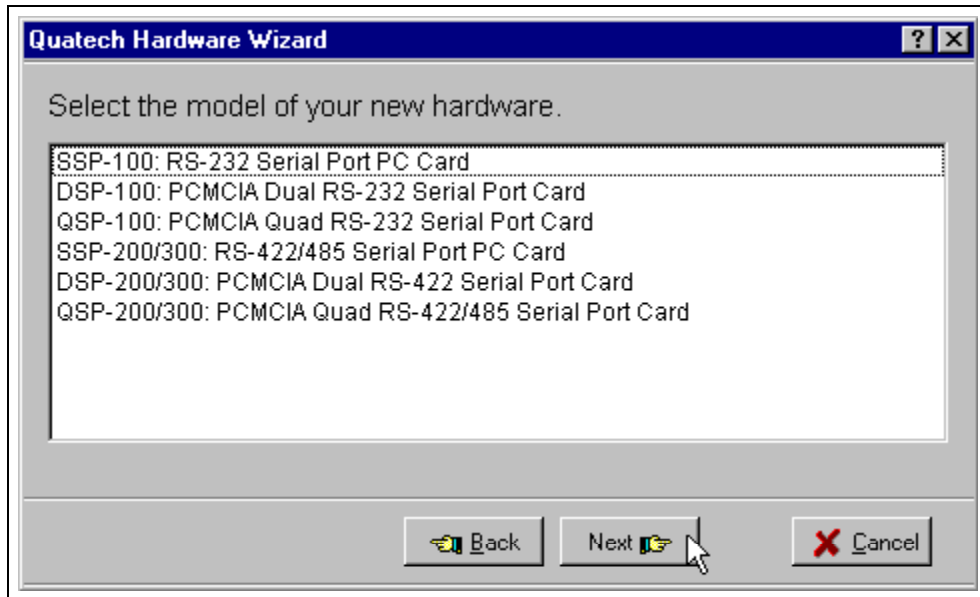

4. Complete the final steps of the installation, shut down Windows NT and then insert the PCMCIA Card and re-boot the computer.

Additional help is available online

The DSP-200/300 PC Card should now be configured. In the future, Windows NT will automatically recognize and configure the DSP-200/300.

Note: Windows NT does not support 'Plug and Play' for PCMCIA cards. The PCMCIA Card must be inserted prior to starting Windows NT and can not be removed and reinserted while Windows NT is running.

6. Hardware Information

6.1 Auxiliary Channel Configuration

An auxiliary channel is provided which allows for handshaking between the DSP-200/300 port and a peripheral device. This auxiliary channel may be configured in one of two ways:

- RTS-CTS handshake enabled.
- handshaking is disabled.

6.1.1 Auxiliary Channel: RTS-CTS Handshaking.

The RTS-CTS handshake may be enabled so that RTS (request to send) is the auxiliary output signal on AUX OUT+ (pin 1) and AUX OUT- (pin 6). Similarly, CTS (clear to send) is the auxiliary input signal on AUX IN+ (pin 5) and AUX IN- (pin 9). This configuration is shown below.

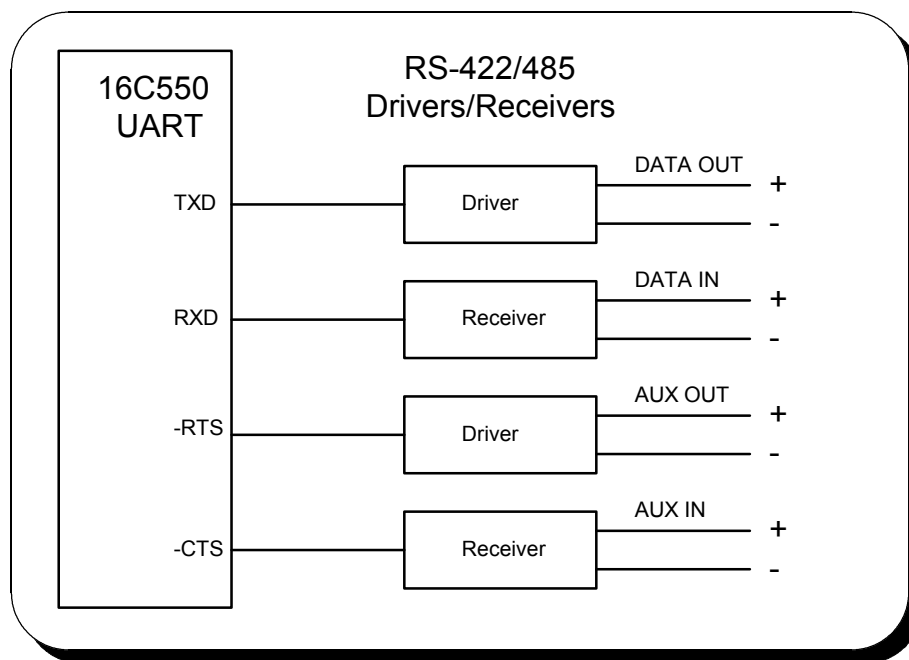

Figure 9. Auxiliary Channel RTS-CTS Handshaking

6.1.2 Auxiliary Channel: Handshaking Disabled.

The DSP-200/300 ports may be configured so that the RTS-CTS handshake is disabled. This is the default configuration. In this configuration, RTS and CTS from the 16C750 UART will be looped back to each other. In addition, the auxiliary output and input signals will be looped back to each other. This configuration is shown below:

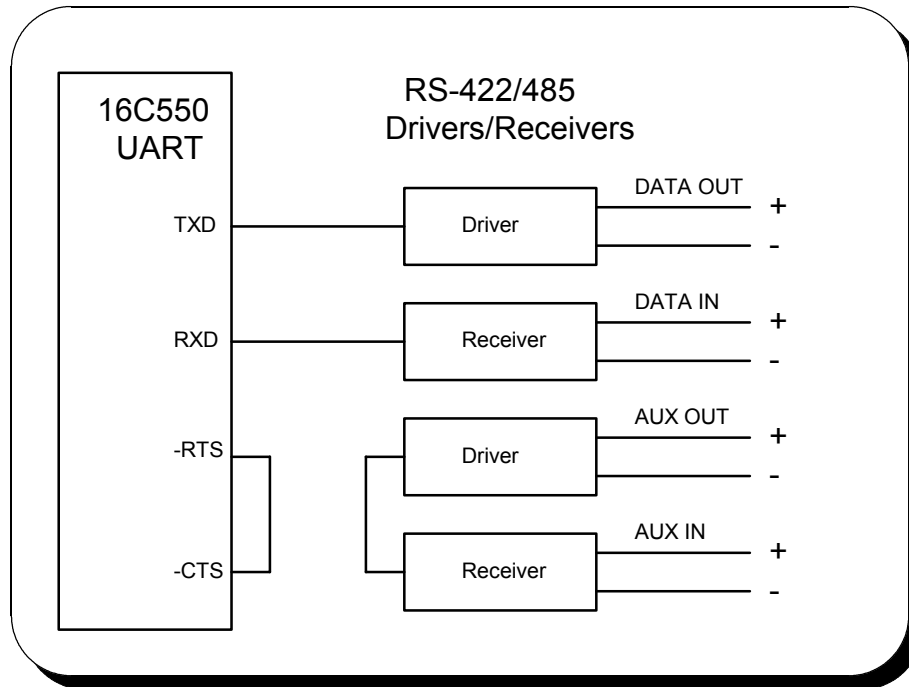

Figure 10. Auxiliary Channel Handshaking Disabled

6.2 Half Duplex Operation

The DSP-200/300's ports may be configured for either full duplex or half duplex operation. By default, the RS-422/485 ports are configured for full duplex operation with the RS-422/485 output drivers always enabled.

In half duplex mode, the RS-422/485 transmitter may be enabled and disabled via the RTS (request to send) or DTR (data terminal ready) signals. Both RTS and DTR are controlled through the Modem Control Register of the 16750.

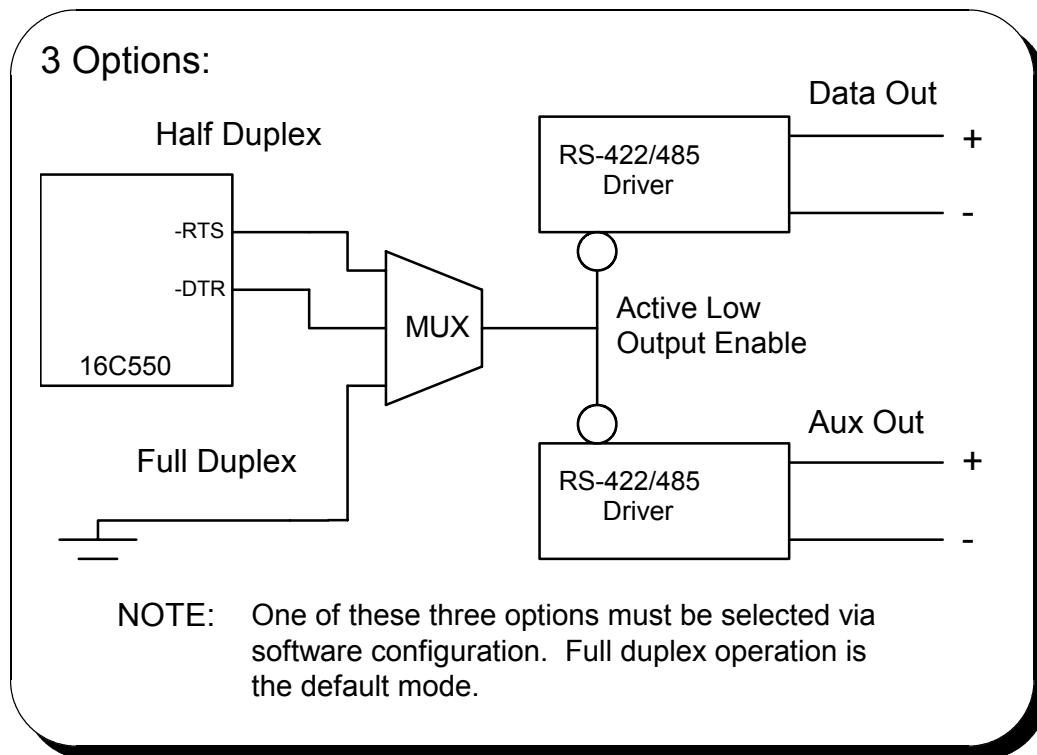

Figure 11. RS-422/485 Driver Enable Options

If RTS is selected as the signal to enable the output drivers, setting 'bit 1' of the Modem Control Register (to logic '1') will enable the output drivers and clearing 'bit 1' of the Modem Control Register (to logic '0') will force the outputs into a high impedance state.

Similarly, if DTR is chosen as the signal to enable the output drivers setting 'bit 0' of the Modem Control Register (to logic '1') will enable the output drivers and clearing 'bit 0' of the Modem Control Register (to logic '0') will force the outputs into a high impedance state.

Selection of half duplex mode operation is dependent upon the configuration software and/or the operating system used. Each of these, however, ultimately control the half duplex mode by accessing the PCMCIA Configuration Register on the DSP-200/300.

CAUTION:

When operating in half duplex mode, the transmitter output drivers **must be** disabled before receiving any information. Failure to do so will result in two output drivers being connected together which may cause damage to the adapter, the computer, and/or the peripheral equipment.

6.3 Termination Resistors

No termination resistors are provided on the DSP-200/300 ports. Both output and input signals are connected only to the external connector. Any termination which is required must be added externally.

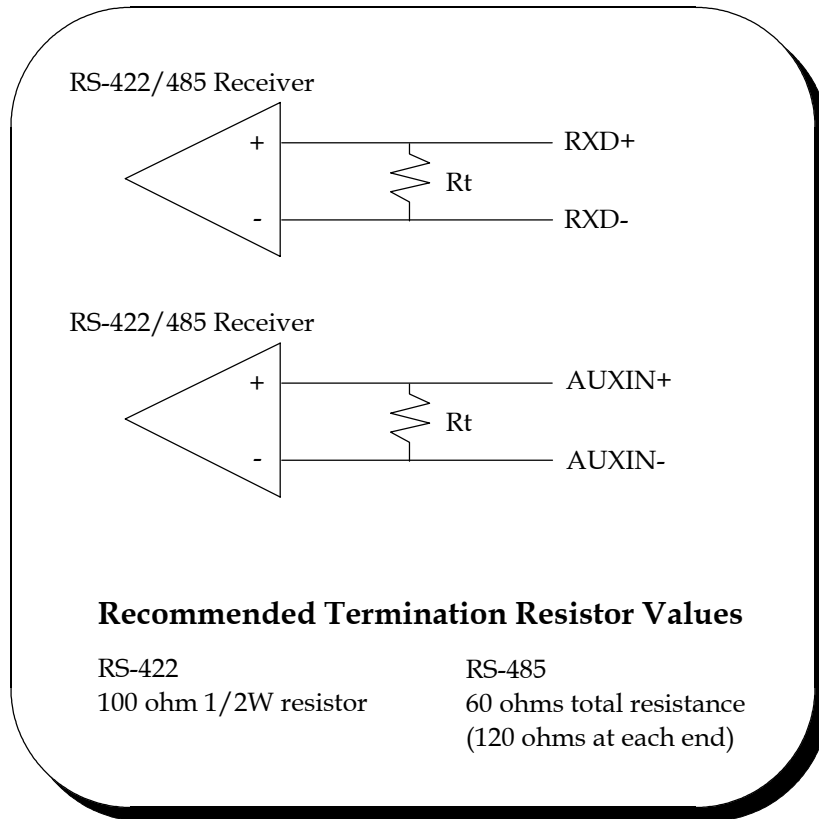

Figure 12. RS-422/485 Termination

This page intentionally left blank.

7. External Connections

An adapter cable is included with the DSP-200/300 to convert the 9-pin PCMCIA output connector into a standard D-9 female connector, data terminal equipment (DTE), as shown in the figures below.

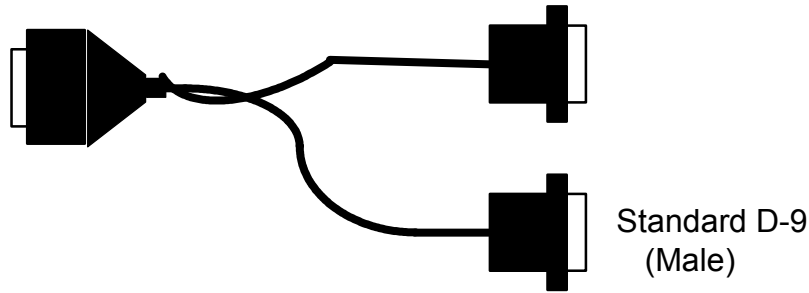

Figure 14. DSP-200/300 Adapter Cable.

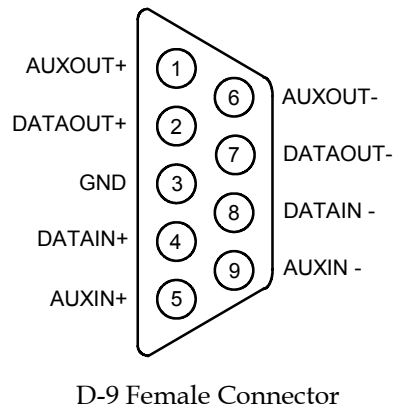

Figure 15. RS-422/485 Signal Assignment.

This page intentionally left blank.

8. Specifications

Bus Interface	PCMCIA PC Card Standard 2.1 compliant
Physical Dimensions	Type II PCMCIA card (5mm)
Maximum Baud Rate	921.6K
Power Requirements (maximum)	+5 volts 20 mA (typical) 30 mA
Connector	Adapter to standard female D-9

DSP-200/300
User's Manual
Revision 3.12
March 2004
P/N 940-0075-312

Quatech, Inc.

Free Manuals Download Website

<http://myh66.com>

<http://usermanuals.us>

<http://www.somanuals.com>

<http://www.4manuals.cc>

<http://www.manual-lib.com>

<http://www.404manual.com>

<http://www.luxmanual.com>

<http://aubethermostatmanual.com>

Golf course search by state

<http://golfingnear.com>

Email search by domain

<http://emailbydomain.com>

Auto manuals search

<http://auto.somanuals.com>

TV manuals search

<http://tv.somanuals.com>