

OWNER'S MANUAL

Mobile Audio System

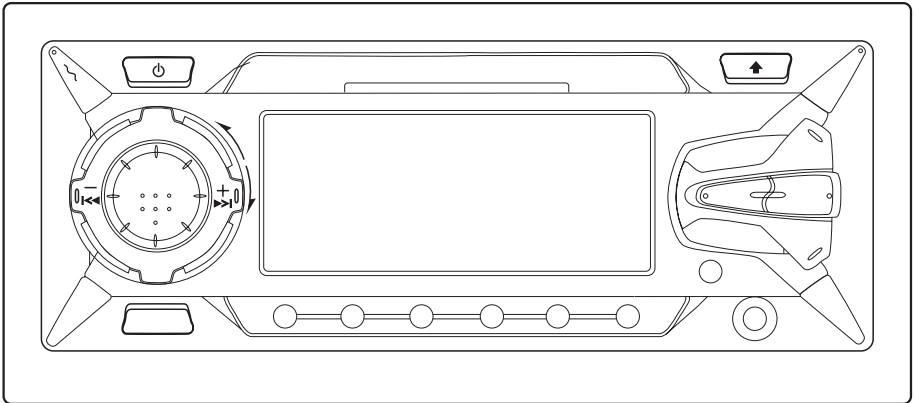

- **PLL Synthesizer Stereo Radio**
- **Digital Compact Disc Player**
- **Cassette Player**
- **Automatically Memory Storing**
- **Preset Equalization**
- **Auxiliary Input Function**
- **Remote Control**
- **Undetachable Panel**

CONTENTS

Installation	3
Wiring Connection	4
4 x 50W System.....	4
Operation	5
General Operation	6
Radio Operation.....	7
Cassette Operation.....	7
CDP Operation.....	8
Remote Control.....	8
Specifications.....	9
Trouble Shooting	10
Maintenance	11
Caution.....	12
Ignition and Interference Noise	12

INSTALLATION

Method A

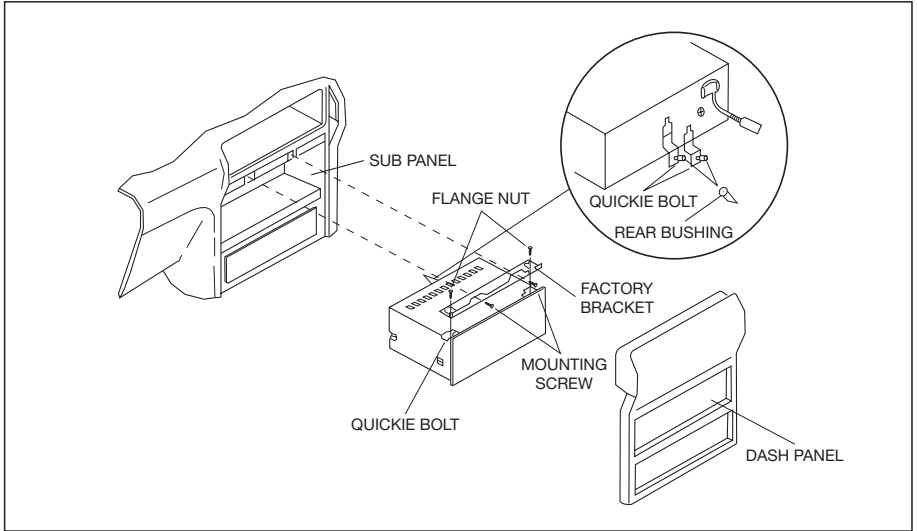

Method B

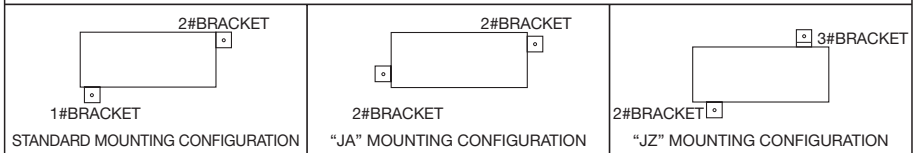
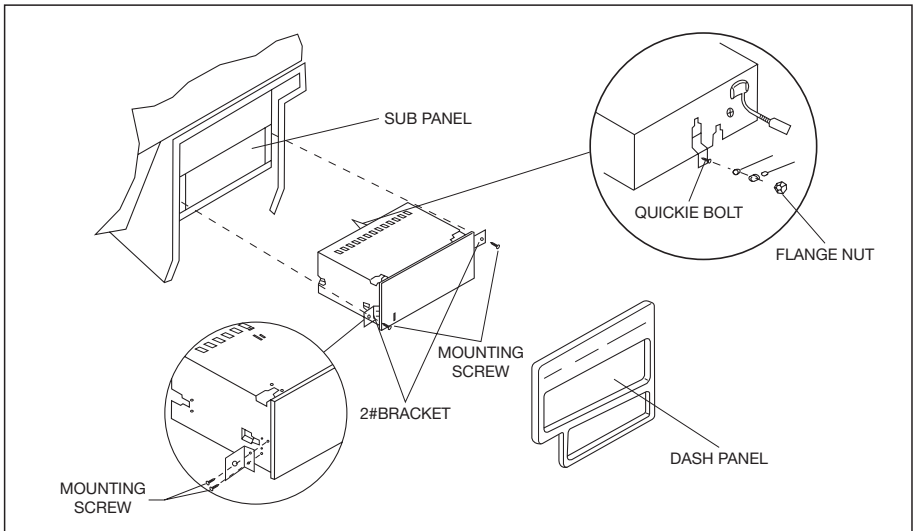

WIRING CONNECTION

For 4 x 50W System

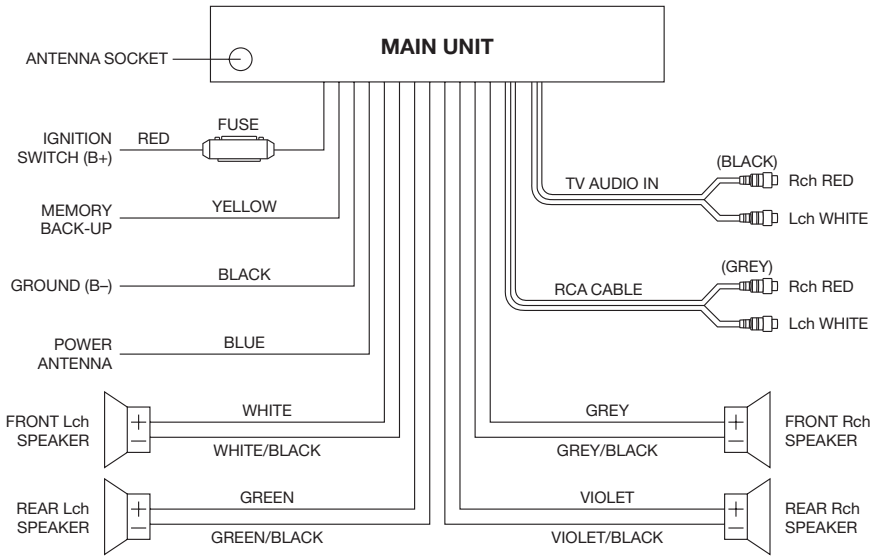

OPERATION

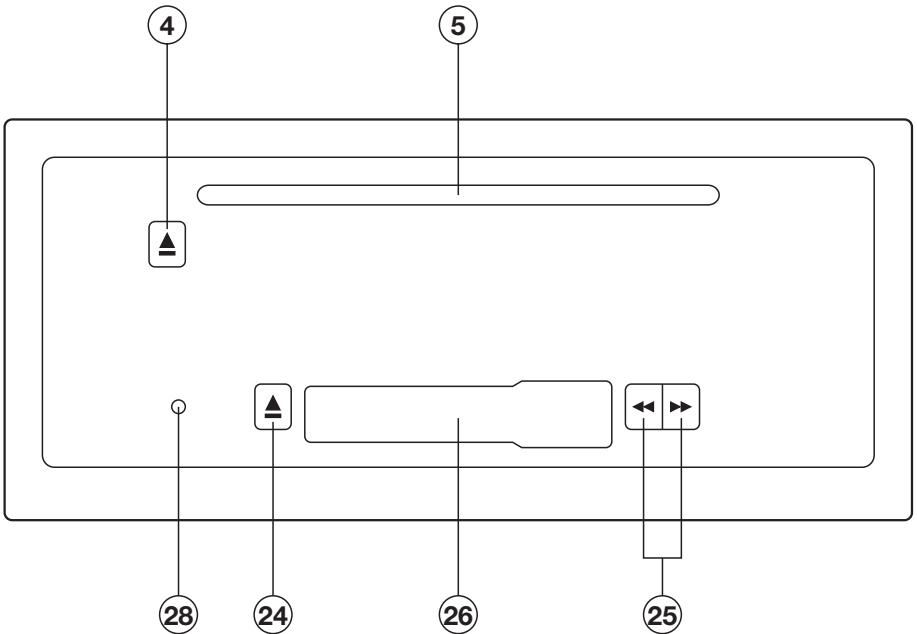
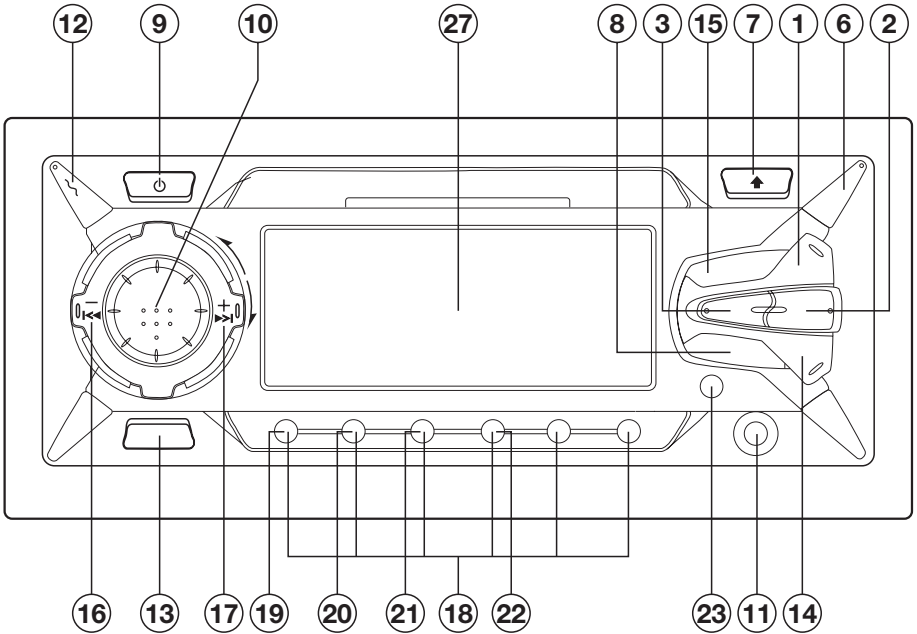

OPERATION

GENERAL OPERATION

Note: In this product design, there has different sound accompanying with every button pressed and the sound is designed differently according to the customers.

- **ON/OFF**

Switch on the unit by pressing **POWER** button (9). When system is on, press **POWER** button (9) again to turn off the unit.

- **OPEN THE FRONT PANEL**

Press **OPEN** button (7) to fold down the front panel.

- **SOUND ADJUSTMENT**

Press **PUSH SELECT** button (10) to select audio mode shown in the below sequence.

► VOLUME → BASS → TREBLE → BALANCE → FADER
(For Fader Version Only)

By rotating the knob (10) clockwise or counter-clockwise, it is possible to adjust the desired sound quality.

If adjustment has not been done in BAS/TRE/BAL/FAD mode, it is returned to the volume select mode (initial) 5 seconds later.

Note: Only in fader version, fader is effective.

- **LOUDNESS**

Press the **LOUD** button (3) to loudness function and display will show “**LOUD**”. Press it again to release this function.

- **DISPLAY**

Press the **DSP** button (15) can switch between frequency or play time display and clock display.

To set clock, hold down **DSP** button (15) until the clock is shown on display then press **TUNE/TRACK/SKIP** ↕ button (17) to change hours or **TUNE/TRACK/SKIP** ⇐ button (16) to change minutes.

- **SELECT MODE**

Press the **MODE** button (6) to choose desired listening mode. (e.g. radio, CDP, CDC, tape, TV or AUX mode)

- **MUTE**

Press the **MUTE** button (2) to silence the receiver. Press it again to release the mode.

- **LIQUID CRYSTAL DISPLAY**

Exhibit current frequency and activated functions on the display (27).

- **EQUALIZATION**

Press **EQ** button (12) to select SOUND EFFECT as shown in below sequence:

► NORMAL → CLAS → POP → JAZZ

Press **EQ** button (12) over 1 second, graphic display type will display on the LCD and then press

TUNE/TRACK/SKIP ⇐ button (16) or **TUNE/TRACK/SKIP** ↕ button (17) to select graphic display type as follows:

► DNC01 → DNC02 → DNC03 → DNC04 → DNC05

- **REMOTE SENSOR**

Point the remote control handset to the remote sensor **IR** (23). Press the function keys on the handset to control the system.

- **AUXILIARY INPUT**

The unit can be connected to a portable audio player through the **AUX IN** jack (11).

- **RESET**

RESET button (28) must be activated with either a ball point pen or thin metal object. The **RESET** button (28) is to be activated for the following reasons:

- Initial installation of the unit when all wiring is completed.
- All the function buttons do not operate.
- Error symbol on the display.

OPERATION

RADIO OPERATION

• BAND SELECTION

At radio mode, press **BAND** button (13) to select the desired band. The reception band will change in the following order:

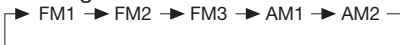

• STATION SELECTION

- Manual Tune Up/Down
Repeatedly press the **TUNE/TRACK/SKIP** button (16) or **TUNE/TRACK/SKIP** button (17) for manual tuning frequency downward or upward.
- Seek Tune Up/Down
Press and hold the **TUNE/TRACK/SKIP** button (16) or **TUNE/TRACK/SKIP** button (17) for several seconds for auto tuning frequency downward or upward.

• LOCAL/DISTANT

Press **LOC** button (1) shortly to select between local and distant stations. Local setting for reception of strong station, and a distant setting for reception of weaker stations. In local mode, "**LOC**" will display.

• MONO/STEREO

At FM radio mode, press **MO/ST** button (8) to set the reception between mono mode and stereo mode. In stereo mode, when stereo broadcasting station is received, the "" indicator will appear upon the display.

• AUTOMATIC MEMORY STORING & PRESET SCAN

- Automatic Memory Storing
Press **AS/PS** button (14) over 1 second in radio mode, Auto Store is started. Stations are searched automatically from next frequency and detected station is stored into the preset memory. In case of LOC state, the first Auto Store is done by LOC state and if 6 CH is not fully

memorized, the seconds Auto Store search continued by Distant state. At the end of Auto Store operation, mode is change to Preset Scan.

- Preset Scan
Press **AS/PS** button (14) shortly in radio mode, Preset Scan is started. This operation starts from next preset number and finished at the same preset number of which last channel memory stored. Frequency of preset memory is displayed with blinking for 5 seconds. Press **AS/PS** button (14) again to release this function.

• STATION STORING

Press and release any one of the preset buttons (18) (1 - 6) shortly, (1 - 6) preset memory is called (Preset Call). Press the button for several seconds, current frequency is stored into preset memory and preset number (1 - 6) is displayed (Preset Store).

CASSETTE OPERATION

• PROGRAM BUTTON

These two buttons (25) perform the dual functions of changing the direction of tape playback and fast forward/rewind of the tape.

- Change Tape Playback Direction
Press both buttons together to play the other side of a tape.
- Fast Forward/Rewind
Press the button with the double arrows pointing the same direction as the direction indicator in the LCD to fast forward; press other button in the opposite direction to fast rewind.

• EJECT

Push the eject button (24) down to eject the cassette tape.

• CASSETTE COMPARTMENT

Insert a cassette tape into the cassette compartment (26). The cassette mechanism will load it in play mode.

OPERATION

CDP OPERATION

• SELECT TRACKS

Press **TUNE/TRACK/SKIP** ◀ button (16) or **TUNE/TRACK/SKIP** ▶ button (17) to move to the previous track or the following track. Track number shows on display.

Hold **TUNE/TRACK/SKIP** ◀ button (16) or **TUNE/TRACK/SKIP** ▶ button (17) to fast reverse or fast forward. CD play starts from when you release the button.

• PAUSE PLAYING

Press **PAU** button (19) to pause CD player. Press it again to resume play.

• REPEAT THE SAME TRACK

Press **RPT** button (21) to continuously repeat the same track. Press it again to stop repeat.

• PREVIEW ALL TRACKS

Press **SCN** button (20) to play first several seconds of each track on the current disc.

Press it again to stop intro and listen to track.

• PLAY ALL TRACKS

Press **RND** button (22) to play all tracks on CD in random order. Press it again to cancel the function.

• EJECT

When the front panel is folded down, press eject button (4) to stop CD playing and eject the disc from the disc slot (5).

REMOTE CONTROL HANDSET

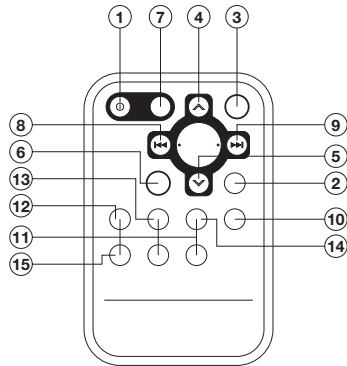

FUNCTION KEYS & CONTROL

1. PWR	= Power Button
2. MUT	= Mute Button
3. SEL	= Select Button
4. VOL ▲	= Volume Up Button
5. VOL ▼	= Volume Down Button
6. BND	= Band Select Button
7. MOD	= Mode Button
8. TUNE/SEEK ◀	= Tune/Seek Down Button
9. TUNE/SEEK ▶	= Tune/Seek Up Button
10. EQ	= Preset Equalization Button
11. PRESET	= Preset Buttons
12. PAU	= Pause Button
13. SCN	= Scanning Button
14. RPT	= Repeat Button
15. RND	= Random Button

SPECIFICATIONS

GENERAL

Power Supply Requirements : DC 12 Volts, Negative Ground
Chassis Dimensions : 200 mm (W) x 138 mm (D) x 75 mm (H)
Loading Impedance : 4 - 8 Ω per channel
Maximum Output Power : 4 x 50 Watts
Current Drain : 10 Ampere (max.)

CD PLAYER

Signal to Noise Ratio : More than 55 dB
Channel Separation : More than 50 dB
Frequency Response : 20 Hz - 20 KHz

CASSETTE PLAYER

Tape Speed : 4.76 cm/sec
Fast Forward Time : 180 seconds (C-60 type)
Frequency Response : 50 to 8,000 Hz
Channel Separation : > 35 dB
Crosstalk : > 40 dB
Wow and Flutter : \leq 0.35% WRMS

RADIO

FM

Frequency Coverage : 87.5 to 107.9 MHz
I.F. : 10.7 MHz
Sensitivity (S/N = 30 dB) : 3 μ V
Image Rejection : > 45 dB
Stereo Separation : > 30 dB

AM

Frequency Coverage : 530 to 1710 KHz
I.F. : 10.71 MHz
Sensitivity (S/N = 20 dB) : 32 dBu

TROUBLE SHOOTING

Before going through the check list, check wiring connection. If any of the problems persist after check list has been made, consult your nearest service dealer.

Symptom	Cause	Solution
No power.	The car ignition switch is not on.	If the power supply is properly connected to the car accessory circuits, but the engine is not moving, switch the ignition key to "ACC".
	The fuse is blown.	Replace the fuse.
Disc cannot be loaded or ejected.	Presence of CD disc inside the player.	Remove the disc in the player, then put a new one.
	Inserting the disc in reverse direction.	Insert the compact disc with the label facing upward.
	Compact disc is extremely dirty or defective disc.	Clean the disc or try to play a new one.
	Temperature inside the car is too high.	Cool off or until the ambient temperature return to normal.
	Condensation.	Leave the player off for an hour or so, then try again.
Cassette tape cannot be loaded or ejected.	Presence of a cassette tape in the player.	Remove the cassette tape in the player, then put in the new one.
	The temperature in the car is too high.	Cool off the inside of the car, then try again.
	Condensation.	Leave the cassette player off for an hour or so, then try again.
No sound.	Volume is in minimum.	Adjust volume to a desired level.
	Wiring is not properly connected.	Check wiring connection.
Sound skips or sound quality is poor.	The installation angle is more than 30 degrees.	Adjust the installation angle to less than 30 degrees.
	The disc is extremely dirty or defective disc.	Clean the compact disc, then try to play a new one.
	The cassette is defective.	Try another cassette.
The operation keys do not work.	The built-in microcomputer is not operating properly due to noise.	Press the RESET button. Front panel is not properly fixed into its place.
The radio does not work. The radio station automatic selection does not work.	The antenna cable is not connected.	Insert the antenna cable firmly.
	The signals are too weak.	Select a station manually.

MAINTENANCE

For System

The following suggestions help you care for the product so that you can enjoy it for years.

1. Keep the product dry. If it does get wet, wipe it dry immediately. Liquids might contain minerals that can corrode the electronic circuits.
2. Keep the product away from dust and dirt, which can cause premature wear of parts.
3. Handle the product gently and carefully. Dropping it can damage circuit boards and cases, and can cause the product to work improperly.
4. Wipe the product with a dampened cloth occasionally to keep it looking new. Do not use harsh chemicals, cleaning solvents, or strong detergents to clean the product.
5. Use and store the product only in normal temperature environments. High temperature can shorten the life of electronic devices, damage batteries, and distort or melt plastic parts.

3. Clean the tape head with the cotton swab.

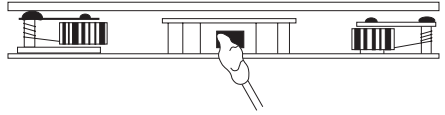

4. Clean the capstans and the pinch rollers with the cotton swab.
5. Allow the tape head, capstans and pinch rollers to dry before operating.
6. Do not touch the tape with your fingers; if it becomes loose, wind it back by twisting a six-sided pencil in the cassette reel.

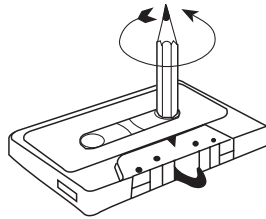

For Tape Player

Periodic cleaning of the tape head and capstan shaft will ensure good reproduction of music and trouble-free operation. Cleaning of the tape head should be done every 20 to 30 hours of operation or when the high tones have become less clear.

1. Use a cassette cleaning cartridge if available. If one is not available, use a cotton swab soaked in isopropyl (rubbing) alcohol.
2. While holding the tape door open, locate tape head to the right of the opening and in the centre of the unit.

CAUTION

1. This unit is designed to operate on 12-volts DC, negative ground electrical system only. Do not attempt to install this unit in a vehicle having a positive ground system.
2. You should not touch the high-polished playback head with any metallic or magnetic tools.
3. Your unit has built-in filtering to eliminate most of the noise that might come through the power source. However, with some vehicles, particularly older models, some clicking or other unwanted noise might be present.

IGNITION AND INTERFERENCE NOISE

Ignition

The most common source of noise in reception is the ignition system. This is normally due to the fact that radio is placed relatively close to the ignition system (engine). This type of noise can be easily detected because it will vary in intensity of pitch with the speed of the engine.

Usually, the ignition noise can be suppressed considerably by using a radio suppression type high voltage ignition wire and suppressor resistor in the ignition system. (Most vehicles employ this wire and resistor but it may be necessary to check them for correct operation.) Another method of suppression is the use of additional noise suppressors. These can be obtained from most CB/Amateur radio or electronic supply shops.

Interference

Radio reception in a moving environment (automobile) is very different from reception in a stationary (home). It is very important to understand the difference.

AM reception will deteriorate when passing through a tunnel or when passing under high voltage lines. Also, noise can be picked up from passing automobiles. Although AM is subject to environmental noise, it has the ability to be received at great distance. This is due to the fact that broadcasting signals follow the curvature of the earth and are reflected back by the upper atmosphere.

FM reception is just the opposite of AM. It is not subject to environmental noise and it does not have the ability to be received at great distances (usually 30 miles). Also, the FM signal can be blocked by tall buildings, mountains, or hills.

To reduce the possibility of these problems, ALWAYS FINE TUNE a station, and if possible, set the antenna height to 30 inches.

Free Manuals Download Website

<http://myh66.com>

<http://usermanuals.us>

<http://www.somanuals.com>

<http://www.4manuals.cc>

<http://www.manual-lib.com>

<http://www.404manual.com>

<http://www.luxmanual.com>

<http://aubethermostatmanual.com>

Golf course search by state

<http://golfingnear.com>

Email search by domain

<http://emailbydomain.com>

Auto manuals search

<http://auto.somanuals.com>

TV manuals search

<http://tv.somanuals.com>