



Cat. No. 43-1089
OWNER'S MANUAL

Please read before using this equipment.

ET-919

9-Memory 900-MHz Cordless Telephone



RadioShack®

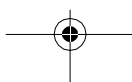

FEATURES

Your RadioShack ET-919 9-Memory 900-MHz Cordless Telephone uses the 900 MHz band which means less interference, clearer sound, and greater range than 46/49 MHz cordless telephones. Its cordless operation lets you make or answer calls just about anywhere in your home or office.

And, its headset jack means you can connect an optional headset for hands-free convenience while you use the phone.

The ET-919's features include:

900 MHz Operation — provides better sound and less interference than many other cordless phones.

20 Channels — automatically selects a clear channel when you make or answer a call. You can also manually change channels during a call.

Super CCT Noise-Reduction Circuitry — gives you sound clarity comparable to that of a corded phone.

Security Access-Protection Code — automatically prevents other cordless phone users from using your phone line while the handset is off the base.

COM-LOK[®] — ensures that other cordless phone users cannot use your phone line when the handset is on the base.

Redial — lets you quickly redial the last number dialed.

9-Number Memory Dialing — lets you store up to 9 numbers in memory for easy dialing.

Page — lets you send a paging signal from the base to the handset to page someone or locate the handset if you misplace it.

Flash — sends an electronic switch-hook signal for use with special phone services, such as Call Waiting.

Mute — prevents the person on the phone from hearing your conversation with someone in the room.

Volume Control — lets you adjust the volume you hear through the handset.

Tone/Pulse Dialing — lets you use your phone with touch-tone or pulse service.

Quick Talk — lets you answer a call by just lifting the handset from the base.

Hearing-Aid Compatibility — lets you use your phone with hearing aids that have a T (telephone) switch.

© 1998 Tandy Corporation.
All Rights Reserved.

COM-LOK and RadioShack are registered trademarks used by Tandy Corporation.

This telephone has been tested and found to comply with all applicable UL and FCC standards.



Your telephone operates on standard radio frequencies as allocated by the FCC. Even though the security access-protection code prevents unauthorized use of your phone line, it is possible for other radio units operating on similar frequencies within a certain area to unintentionally intercept your conversations and/or cause interference. This lack of privacy can occur with any cordless phone.

Important Note: Cordless phones such as this one require AC power to operate. When the AC power is off, you cannot dial out or receive incoming calls using your phone. To be safe, you should also have a phone that does not need AC power to operate (not a cordless phone) so you can still make and receive calls if there is an AC power failure.

We recommend you record your phone's serial number here. The number is on the bottom of the base.

Serial Number: _____

WARNING: To reduce the risk of fire or shock hazard, do not expose this product to rain or moisture.

| | | |
|--|---|---|
|  | CAUTION RISK OF ELECTRIC SHOCK. DO NOT OPEN. |  |
| CAUTION: TO REDUCE THE RISK OF ELECTRIC SHOCK, DO NOT REMOVE COVER OR BACK. NO USER-SERVICEABLE PARTS INSIDE. REFER SERVICING TO QUALIFIED PERSONNEL. | | |



This symbol is intended to alert you to the presence of uninsulated dangerous voltage within the product's enclosure that might be of sufficient magnitude to constitute a risk of electric shock. Do not open the product's case.



This symbol is intended to inform you that important operating and maintenance instructions are included in the literature accompanying this product.

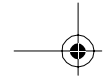

READ THIS BEFORE INSTALLATION

Each device that you connect to the phone line draws power from the phone line. We refer to this power draw as the device's *ringer equivalence number*, or REN. The REN is on the bottom of the base.

If you are using more than one phone or other device on the line, add up all the RENs. If the total is more than five, your phones might not ring. In rural areas, a total REN of three might impair ringer operation. If ringer operation is impaired, remove a device from the line.

FCC STATEMENT

This telephone complies with Part 68 of *FCC Rules*. You must, upon request, provide the FCC Registration Number and the REN to your phone company. These numbers are located on the bottom of the base.

Note: You must not connect your phone to any of the following:

- coin-operated systems
- party-line systems
- most electronic key phone systems

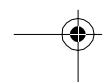
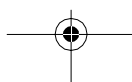
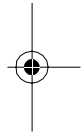
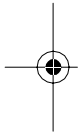

CONTENTS

| | |
|--|-----------|
| Preparation | 6 |
| Selecting a Location | 6 |
| Attaching the Handset's Antenna | 6 |
| Placing the Base on a Desk Top | 7 |
| Mounting the Base on a Wall Plate | 8 |
| Mounting the Base Directly on the Wall | 9 |
| Connecting and Charging the Battery Pack | 11 |
| Setting the Dialing Mode | 12 |
| Turning the Ringer On/Off | 13 |
| Operation | 14 |
| Making and Receiving Calls | 14 |
| Selecting the Channel | 14 |
| Using Mute | 14 |
| Setting the Handset's Volume | 15 |
| Using Redial | 15 |
| Using Flash | 15 |
| Using Tone Services on a Pulse Line | 16 |
| Using Page | 16 |
| Memory Dialing | 16 |
| Storing a Number in Memory | 16 |
| Entering a Pause | 17 |
| Dialing a Memory Number | 17 |
| Chain-Dialing Service Numbers | 17 |
| Testing Stored Emergency Numbers | 18 |
| Using a Headset | 18 |
| Troubleshooting | 19 |
| Care and Maintenance | 21 |
| Replacing the Battery Pack | 22 |
| The FCC Wants You to Know | 23 |
| Lightning | 23 |

PREPARATION

SELECTING A LOCATION

You can place the phone on a desk top or table, mount it on a standard wall plate, or mount it directly on a wall. Select a location that is:

- near an AC outlet
- near a telephone line jack
- out of the way of normal activities
- away from electrical machinery, electrical appliances, metal walls or filing cabinets, wireless intercoms, alarms, and room monitors
- away from other cordless phones

The base's location affects the handset's range. If you have a choice of several locations, try each to see which provides the best performance.

Caution: The supplied RadioShack AC adapter was designed specifically for your ET-919. Use only the supplied adapter.

Notes:

- Your telephone connects directly to a modular telephone line jack. If your phone line jack is not a modular jack, you can update the wiring yourself, using jacks and adapters available at your local RadioShack store. Or, you can let the phone company update the wiring for you.
- The USOC number of the jack to be installed is RJ11C (RJ11W if you want to mount it on a wall plate).

ATTACHING THE HANDSET'S ANTENNA

Insert the antenna into the hole on the top of the handset, then rotate the antenna clockwise until it is secure.

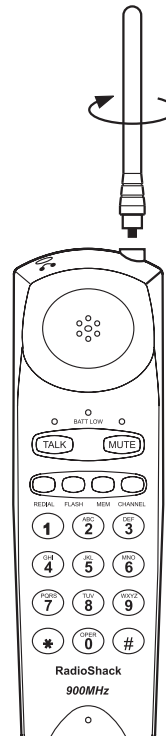

PLACING THE BASE ON A DESK TOP

Follow these steps when you place the base on a desk, shelf, or table.

1. Remove the bracket by holding in both tabs and gently pulling out the wide end of the bracket.

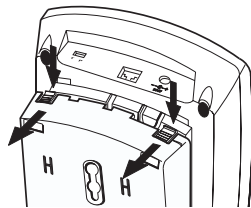

2. Plug one end of the supplied long modular cord into the phone jack on the back of the base.

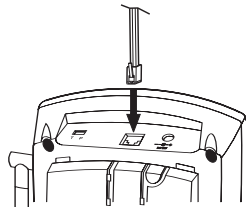

3. Insert the supplied AC adapter's barrel plug into the DC 12V jack on the back of the base.

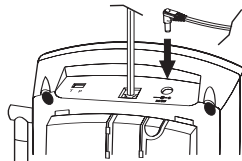

4. Route the adapter's cord through the strain relief slot on the bottom of the base.

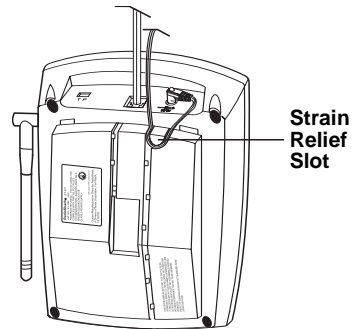

5. Insert the tabs on the narrow end of the bracket into the lower slots on the bottom of the base and push the tabs on the wide end of the bracket into the upper slots on the bottom of the base.

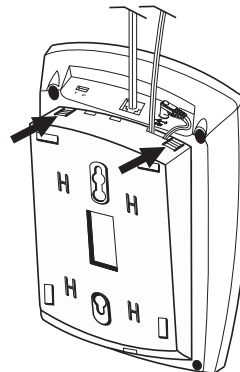

6. Plug the modular cord's other end into a modular phone line jack.

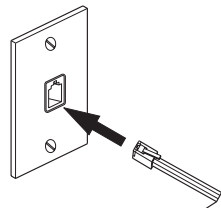

7. Plug the adapter into a standard AC outlet.
8. Lift the base's antenna to a vertical position.

3. Insert the supplied AC adapter's barrel plug into the **DC 12V** jack on the back of the base. Route the adapter's cord through the right slot on the bottom of the base.

MOUNTING THE BASE ON A WALL PLATE

1. Remove the bracket by holding in both tabs and gently pulling out the wide end of the bracket.
2. Plug one end of the supplied short modular cord into the phone jack on the back of the base. Route the modular cord through the left slot on the bottom of the base.

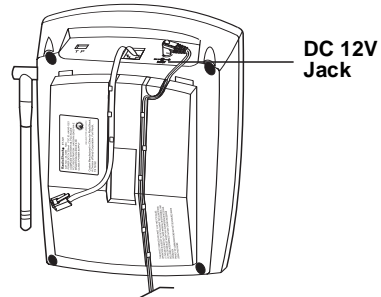

4. Route the other end of the short modular cord through the center of the bracket.

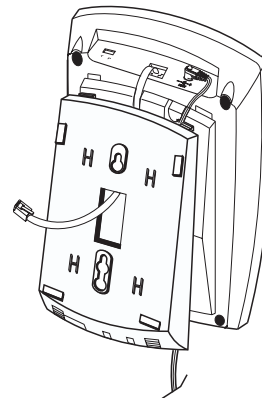
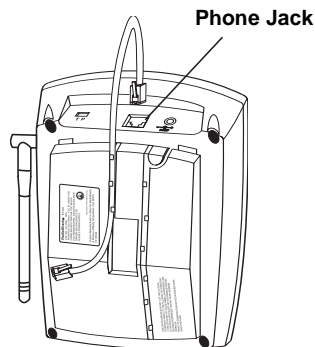

5. Insert the tabs on the narrow end of the bracket into the upper slots on the bottom of the base, then push the tabs on the wide end of the bracket into the lower slots on the bottom of the base.

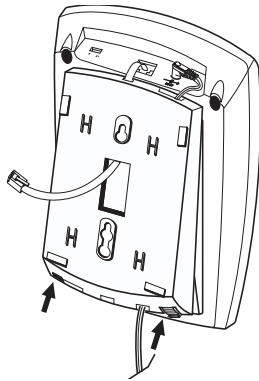

6. Plug the short modular cord into the wall plate jack, align the base's keyhole slots with the wall plate studs, and slide the base downward to secure it.

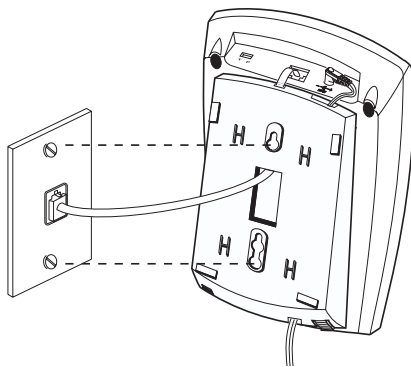

7. Plug the adapter into a standard AC outlet.
8. Lift the base's antenna to a vertical position.

MOUNTING THE BASE DIRECTLY ON THE WALL

For this mounting method, you need two flat-head screws (not supplied) with heads that fit into the keyhole slots on the mounting bracket.

1. Drill two holes $3^{15}/16$ inches (100 mm) apart. Then thread a screw into each hole, letting the heads extend about $3/16$ inch (5 mm) from the wall.

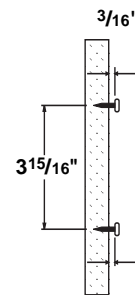

2. Remove the bracket by holding in both tabs and gently pulling out the wide end of the bracket.
3. Plug one end of the supplied long modular cord into the phone jack on the back of the base. Route the modular cord through the left slot on the bottom of the base and pull the cord down to remove any slack on top.

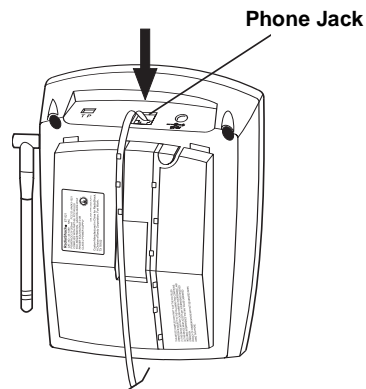

4. Insert the supplied AC adapter's barrel plug into the **DC 12V** jack on the back of the base. Route the adapter's cord through the right slot on the bottom of the base.

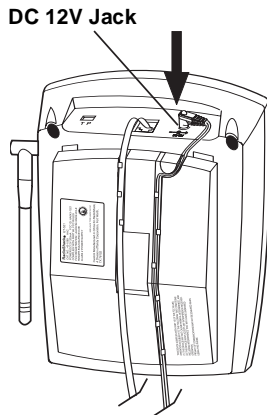

6. Align the keyhole slots with the mounting screws and slide the base downward to secure it.

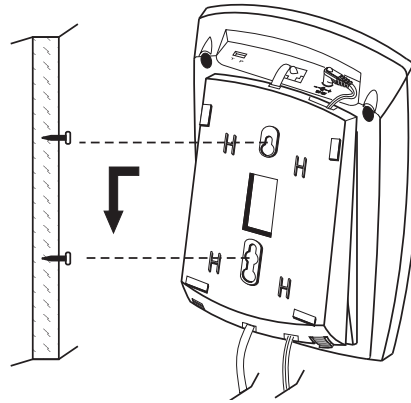

5. Insert the tabs on the narrow end of the bracket into the upper slots on the bottom of the base, guide the modular and adapter cords through the cord slots on the bracket, and push the tabs on the wide end of the bracket into the slots on the bottom of the base.

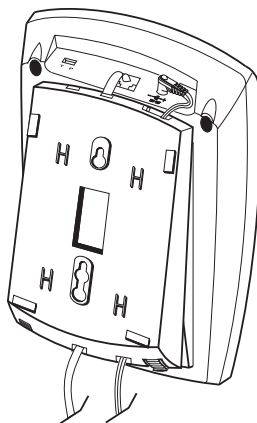

7. Plug the modular cord into a modular phone line jack.

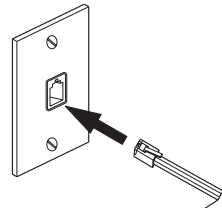

8. Plug the adapter into a standard AC outlet.
9. Lift the base's antenna to a vertical position.

CONNECTING AND CHARGING THE BATTERY PACK

The ET-919 comes with a rechargeable nickel-cadmium battery pack in the handset but not connected. Before using your phone, you must connect the battery pack and then charge it for about 24 hours.

1. Press down and slide off the compartment cover as shown.

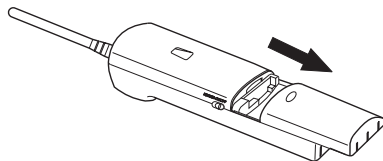

2. Plug the battery pack's plastic connector into its socket. The connector fits only one way.

Note: For easier battery pack connection, lift it out of the compartment, insert its connector into the socket, then replace the battery pack inside the compartment.

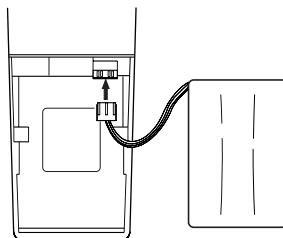

3. Replace the cover.

4. To charge the battery pack, simply place the handset on the base. The CHARGE indicator on the base lights.

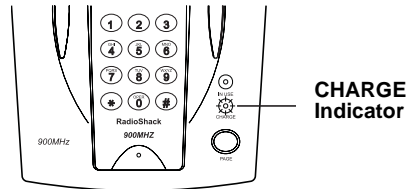

Recharge the battery pack when the BATT LOW indicator flashes.

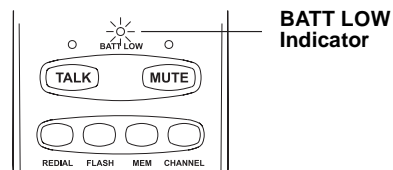

Notes:

- If the CHARGE indicator does not light when you place the handset on the base, be sure the battery pack and AC adapter are correctly and securely connected.

Also, check the charging contacts on the handset and the base. If the contacts are dirty or tarnished, clean them with a pencil eraser.

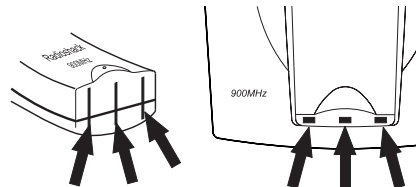

- When you first use the phone after charging or recharging the battery pack, the phone might not work and you might hear an error tone. If this happens, return the handset to the base for a few seconds.
- About once a month, fully discharge the battery pack by keeping the handset off the base until the BATT LOW indicator flashes. Otherwise, the battery pack loses its ability to fully recharge.
- If the BATT LOW indicator does not light but the phone does not work, recharge the battery pack. (The battery power might be too low to light the indicator.)
- If the battery pack becomes weak during a call, the BATT LOW indicator flashes and you hear three beeps every 30 seconds. Recharge the battery pack.
- If the battery pack gets completely discharged or the base loses power while the handset is away from it, the security access-protection code needs to be reset. To reset the security code, place the handset on the base. If it was the handset that lost power, leave the handset on the base to charge the battery pack.
- The supplied battery pack should last for about a year. When the battery pack loses its ability to fully recharge, order a replacement battery pack from your local RadioShack store (see "Replacing the Battery Pack" on Page 22).

SETTING THE DIALING MODE

Set **T/P** (Tone/Pulse) on the back of the base for the type of service you have. If you are not sure which type you have, once the battery is charged, do this test.

1. Set **T/P** to **T**.

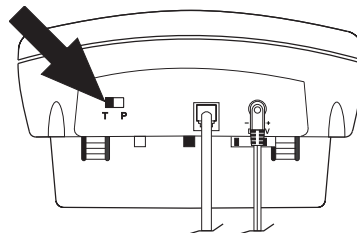

2. Lift the handset, press **TALK**, and listen for the dial tone.

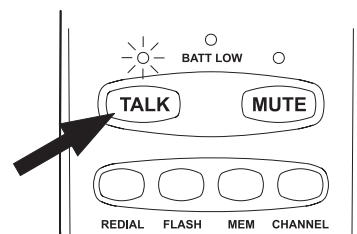

3. Press any number other than **0**.

Note: If your phone system requires that you dial an access code (**9**, for example) before you dial an outside number, do not press the access code either.

If the dial tone stops, you have touch-tone service. Leave **T/P** set to **T**.

If the dial tone continues, you have pulse service. Set **T/P** to **P**.

TURNING THE RINGER ON/OFF

You can turn the ET-919's ringer on and off. Set **RINGER** on the side of the handset to **ON** to hear an incoming call or a page from the base. Set **RINGER** to **OFF** to silence the ringer.

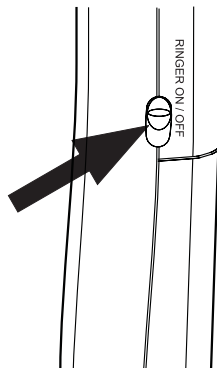

Note: With the ringer off, you can still make or receive calls using this cordless phone. Telephones on the same line still ring when there is an incoming call, and the IN USE indicator on the ET-919's base flashes until you answer the call.

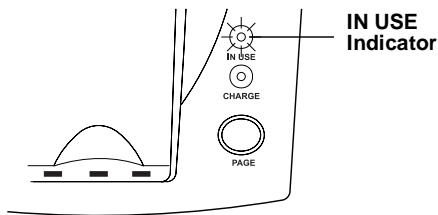

OPERATION

MAKING AND RECEIVING CALLS

To make a call, simply lift the handset and press **TALK**. When you hear the dial tone, dial the desired phone number or memory number (see "Memory Dialing" on Page 16).

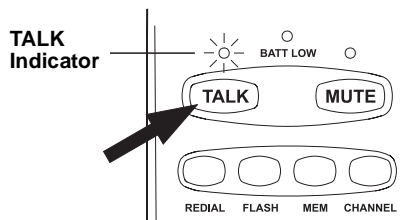

To answer a call if the handset is on the base, simply lift the handset and begin your conversation. Or, if the handset is away from the base, press **TALK**. The TALK indicator on the handset and the IN USE indicator on the base light.

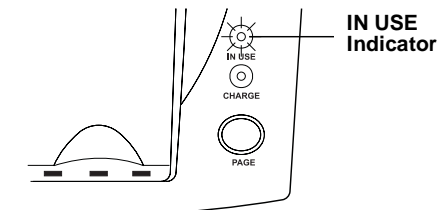

To end a call, place the handset on the base or press **TALK**. The TALK and IN USE indicators turn off.

Note: If you press **TALK** to hang up the phone and the phone does not disconnect, move closer to the base and press **TALK** again or place the handset on the base.

SELECTING THE CHANNEL

The ET-919 scans 20 channels (frequency pairs used between the base and the handset) and automatically selects a clear channel each time you make or receive a call.

If you hear other conversations or excessive noise during a call, press **CHANNEL** to select a different channel. The TALK indicator blinks while your phone searches for a clear channel.

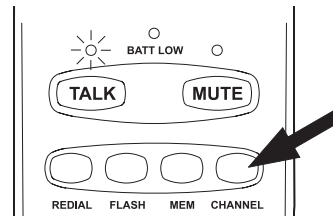

Note: If the handset is too far from the base, the channel might not change. Move closer to the base and try again.

USING MUTE

The **MUTE** button on the handset lets you talk to someone else in the room without the person on the other end of the phone line hearing your conversation.

Press **MUTE** during the call. The MUTE indicator on the handset lights steadily.

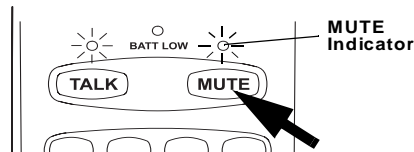

Press **MUTE** again to resume your phone conversation. The MUTE indicator turns off.

SETTING THE HANDSET'S VOLUME

You can select one of three different volume settings (soft, normal, loud) using **VOLUME s** or **t** during a call.

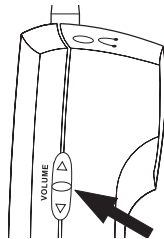

1. Lift the handset and press **TALK**. The TALK indicator lights.
2. Repeatedly press **VOLUME s** to increase the volume level or **VOLUME t** to decrease it.

Note: Every time you press **VOLUME s** or **t**, the ET-919 beeps, except when it is already at the loudest or softest volume level.

USING REDIAL

To quickly redial the last number dialed, press **TALK**. Then when you hear the dial tone, simply press **REDIAL**.

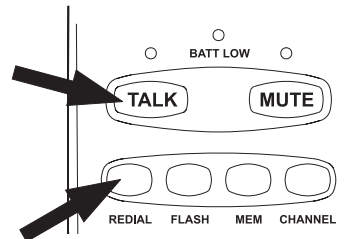

Notes:

- The redial memory holds up to 16 digits, so you can redial long-distance as well as local numbers.
- The redial memory also holds pause entries. See "Entering a Pause" on Page 17.
- The redial memory does not store a flash entry or any digits you press after **FLASH** (see "Using Flash").

USING FLASH

FLASH performs the electronic equivalent of a switchhook operation for special services, such as Call Waiting.

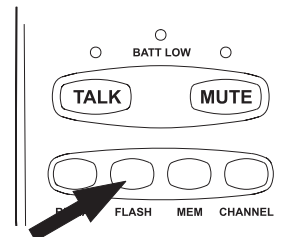

For example, if you have Call Waiting, press **FLASH** to answer an incoming call without disconnecting the current call. Press **FLASH** again to return to the first call.

Note: If you do not have any special phone services, pressing **FLASH** might disconnect the current call.

USING TONE SERVICES ON A PULSE LINE

Some special services, such as bank-by-phone, require tone signals. If you have pulse service, you can still use these special tone services by following these steps.

1. Be sure **T/P** is set to **P**.
2. Dial the service's main number.
3. When the service answers, press *****. Any additional numbers you dial are sent as tone signals.

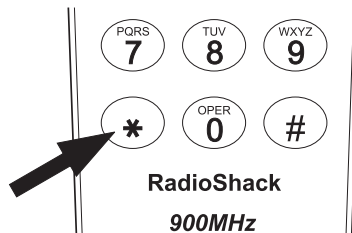

4. After you complete the call, return the handset to the base or press **TALK**. The phone automatically resets to the pulse mode.

USING PAGE

To page the person who has the handset or to locate the handset when the phone is not in use, press **PAGE** on the base. The handset beeps three times. If you hold down **PAGE** for 2–3 seconds, the handset beeps for 3 minutes to give you time to locate the handset.

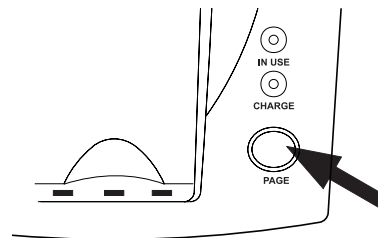

To stop it from beeping before it automatically stops, press **TALK**.

MEMORY DIALING

You can store up to 9 numbers in memory, then dial a stored number by pressing a one-digit memory location number.

Each number you store can be up to 16 digits long.

Storing a Number in Memory

Notes:

- An error tone sounds and the phone exits the programming mode if you wait more than 30 seconds between each keypress or enter more than 16 digits.

- To keep your accounts secure, we recommend you do not store your personal access code for services such as bank-by-phone in a memory location.

1. Press **MEM**. The TALK indicator blinks.

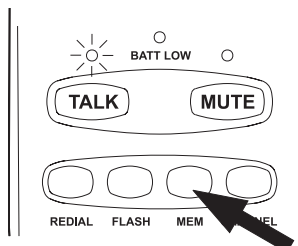

2. Enter the number and any tone and pause entries (see "Entering a Pause").

Note: Each tone or pulse entry uses one digit of memory.

3. Press **MEM** again, then enter the memory location number (1–9) where you want to store the number. A tone sounds to indicate that the number is stored.

To replace a stored number, simply store a new number in its place.

To clear a memory location (leaving it empty), simply skip Step 2 and select the memory location you want to clear in Step 3.

Entering a Pause

In some telephone systems, you must dial an access code (9, for example) and wait for a second dial tone before you can dial an outside number. You can store the access code with the phone number. However, you should also store a pause after the access code to allow the outside line time to connect. To do so, press **REDIAL**. Each press enters a 2-second pause. For a longer pause, press **REDIAL** additional times.

Dialing a Memory Number

To dial a number stored in memory, press **TALK**. The TALK indicator lights.

When you hear a dial tone, simply press **MEM** and enter the memory location number for the number you want to dial.

Chain-Dialing Service Numbers

For quick recall of numbers for special services (such as alternate long distance or bank by phone), store each group of numbers in its own memory location.

When calling special services (such as alternate long distance or bank by phone), dial the service's main number first. Then, at the appropriate place in the call, press **MEM** and the number for the location where the additional information is stored.

Testing Stored Emergency Numbers

If you store an emergency service's number (police department, fire department, ambulance) and you choose to test the stored number, make the test call during the late evening or early morning hours to avoid peak demand periods. Also, remain on the line to explain the reason for your call.

USING A HEADSET

You can make or answer calls with hands-free convenience using an optional headset that has a $\frac{3}{32}$ -inch (2.5 mm) plug. We recommend RadioShack Cat. No. 43-194.

To connect the headset, insert the headset's plug into the  jack on the top of the handset.

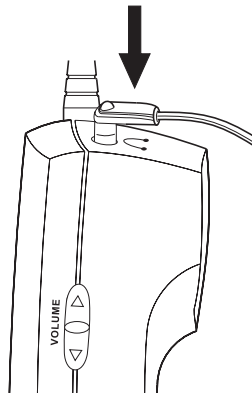

Notes:

- Connecting a headset disconnects the handset's earpiece and microphone.
- If you place the handset on the base to recharge it while the headset is connected, be sure the handset seats properly.

With a headset connected, you make or answer calls as usual using the keys on the handset.

RadioShack also sells a leather carrying case (Cat. No. 43-197) which lets you hang the handset on your belt for hands-free conversation when you are working in the yard or garage.

TROUBLESHOOTING

We do not expect you to have any problems with your phone, but if you do, the following suggestions might help.

| Problem | Suggestion |
|---|--|
| Low volume or unusual sounds. | Someone has picked up another phone on the same line. Hang up the other phone. |
| Severe noise interference. | Press CHANNEL to change the channel. |
| | Keep the handset away from computers, remote control toys, wireless microphones, alarm systems, intercoms, room monitors, fluorescent lights, and electrical appliances. |
| | Move to another location or turn off the source of interference. |
| The phone cannot be operated at a useful distance from the base because the signal becomes weak or noisy (the handset's range has decreased). | Lift the base's antenna to a fully vertical position. |
| | Be sure neither the handset's or base's antenna is touching a metal surface. |
| | Return the handset to the base to recharge the battery pack. |
| The handset battery does not charge. | Check the charging contacts on the handset and base. If they are dirty, clean them with a pencil eraser. |
| | Be sure the battery pack is connected correctly. |
| Handset does not ring or receive a page. | Return the handset to the base to recharge the battery pack. |
| | Lift the base's antenna to a fully vertical position. |
| | Move the handset closer to the base. |
| | Move the base away from other electrical devices. |

| Problem | Suggestion |
|--|---|
| The phone does not work or works poorly. | Be sure the base's phone line cord and AC adapter are correctly and securely connected, and the handset's battery pack is charged. |
| The handset stops working or works poorly during a call. | Move the handset closer to the base. |
| | Be sure the handset's battery pack is charged. (If the battery pack power is too low, it does not have enough power to light the BATT LOW indicator.) |
| | Lift the base's antenna to a fully vertical position. |
| | Make sure the charging contacts on the handset and base are clean. |
| | If the base lost power while the handset was off of it, the security access-protection code might have changed. With the handset removed from the base, restore power to the base, then place the handset back on the base. The CHARGE indicator lights, indicating that the code is set again. |

If you still have problems, disconnect the phone. If other phones on the same line work properly, the fault is in this phone or its installation. If you cannot find the problem, take your ET-919 to your local RadioShack store for assistance.

CARE AND MAINTENANCE

Your ET-919 9-Memory 900-MHz Cordless Telephone is an example of superior design and craftsmanship. The following suggestions will help you care for your cordless telephone so you can enjoy it for years.



Keep the phone dry. If it gets wet, wipe it dry immediately. Liquids might contain minerals that can corrode the electronic circuits.



Handle the phone gently and carefully. Dropping it can damage circuit boards and cases and can cause the phone to work improperly.



Use and store the phone only in normal temperature environments. Temperature extremes can shorten the life of electronic devices and distort or melt plastic parts.



Keep the phone away from dust and dirt, which can cause premature wear of parts.



Wipe the phone with a damp cloth occasionally to keep it looking new. Do not use harsh chemicals, cleaning solvents, or strong detergents to clean the phone.

Modifying or tampering with the phone's internal components can cause a malfunction and might invalidate your phone's warranty and void your FCC authorization to operate it. If your phone is not performing as it should, take it to your local RadioShack store for assistance. If the trouble is affecting the phone lines, the phone company might ask you to disconnect your phone until you have resolved the problem.

REPLACING THE BATTERY PACK

If you follow the instructions in "Connecting and Charging the Battery Pack" on Page 11, the battery pack should last about one year. If the battery does not hold a charge for more than 2 hours after an overnight charge, replace the battery with a new 3.6 volt, 600 milliamp battery pack with a connector that fits the socket in the battery compartment. You can order a replacement battery pack through your local RadioShack store.

Install the new battery pack as described below, then charge the battery pack for about 24 hours (see "Connecting and Charging the Battery Pack" on Page 11).

Note: To avoid losing numbers stored in memory, try to install and begin charging the new battery pack within 3 minutes.

1. Press down and slide off the cover.

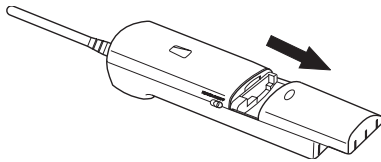

2. Gently pull on the battery pack connector to disconnect it, then remove the battery pack.

3. Plug the new battery pack's connector into the socket and place the battery pack into the compartment.

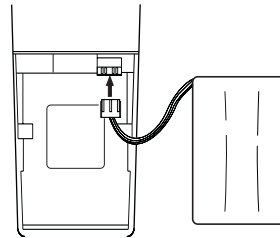

4. Replace the cover.

Cautions:

- You must use a replacement battery pack of the same size and type.
- Do not dispose of the battery pack in a fire because it might explode.
- Do not open or mutilate the battery pack.
- Be careful not to short the battery pack by touching it with conducting materials, such as rings, bracelets, and keys. The battery pack or conductor might overheat and burn.

If you have trouble replacing the battery pack, take the phone to your local RadioShack store for assistance.

Important: This product contains a rechargeable nickel cadmium battery pack. At the end of the battery pack's useful life, it must be recycled or disposed of properly. Contact your local, county, or state hazardous waste management authorities for information on recycling or disposal programs in your area. Some options that might be available are: municipal curb-side collection, drop-off boxes at retailers such as your local RadioShack store, recycling collection centers, and mail-back programs.

THE FCC WANTS YOU TO KNOW

In the unlikely event that your phone causes problems on the phone line, the phone company can temporarily discontinue your service. If this happens, the phone company attempts to notify you in advance. If advance notice is not practical, the phone company notifies you as soon as possible and advises you of your right to file a complaint with the FCC.

Also, the phone company can make changes to its lines, equipment, operations, or procedures that could affect the operation of this telephone. The telephone company notifies you of these changes in advance, so you can take the necessary steps to prevent interruption of your telephone service.

Your phone might cause TV or radio interference even when it is operating properly. To determine whether your phone is causing the interference, turn

off your phone. If the interference goes away, your phone is causing the interference. Try to eliminate the interference by:

- Moving your phone away from the receiver
- Connecting your phone to an AC outlet that is on a different electrical circuit from the receiver
- Contacting your local RadioShack store for help

If you cannot eliminate the interference, the FCC requires that you stop using your phone.

Some cordless telephones operate on frequencies that may cause interference to nearby TVs and VCRs. To minimize or prevent such interference, the base of the cordless telephone should not be placed near or on top of a TV or VCR.

LIGHTNING

Your telephone has built-in lightning protection to reduce the risk of damage from surges in telephone line and power line current. This lightning protection meets or exceeds FCC requirements. However, lightning striking the telephone or power lines can damage your telephone.

Lightning damage is not common. Nevertheless, if you live in an area that has severe electrical storms, we suggest that you unplug your phone during storms to reduce the possibility of damage.



Limited One-Year Warranty

This product is warranted by RadioShack against manufacturing defects in material and workmanship under normal use for one (1) year from the date of purchase from RadioShack company-owned stores and authorized RadioShack franchisees and dealers. EXCEPT AS PROVIDED HEREIN, RadioShack MAKES NO EXPRESS WARRANTIES AND ANY IMPLIED WARRANTIES, INCLUDING THOSE OF MERCHANTABILITY AND FITNESS FOR A PARTICULAR PURPOSE, ARE LIMITED IN DURATION TO THE DURATION OF THE WRITTEN LIMITED WARRANTIES CONTAINED HEREIN. EXCEPT AS PROVIDED HEREIN, RadioShack SHALL HAVE NO LIABILITY OR RESPONSIBILITY TO CUSTOMER OR ANY OTHER PERSON OR ENTITY WITH RESPECT TO ANY LIABILITY, LOSS OR DAMAGE CAUSED DIRECTLY OR INDIRECTLY BY USE OR PERFORMANCE OF THE PRODUCT OR ARISING OUT OF ANY BREACH OF THIS WARRANTY, INCLUDING, BUT NOT LIMITED TO, ANY DAMAGES RESULTING FROM INCONVENIENCE, LOSS OF TIME, DATA, PROPERTY, REVENUE, OR PROFIT OR ANY INDIRECT, SPECIAL, INCIDENTAL, OR CONSEQUENTIAL DAMAGES, EVEN IF RadioShack HAS BEEN ADVISED OF THE POSSIBILITY OF SUCH DAMAGES.

Some states do not allow the limitations on how long an implied warranty lasts or the exclusion of incidental or consequential damages, so the above limitations or exclusions may not apply to you.

In the event of a product defect during the warranty period, take the product and the RadioShack sales receipt as proof of purchase date to any RadioShack store. RadioShack will, at its option, unless otherwise provided by law: (a) correct the defect by product repair without charge for parts and labor; (b) replace the product with one of the same or similar design; or (c) refund the purchase price. All replaced parts and products, and products on which a refund is made, become the property of RadioShack. New or reconditioned parts and products may be used in the performance of warranty service. Repaired or replaced parts and products are warranted for the remainder of the original warranty period. You will be charged for repair or replacement of the product made after the expiration of the warranty period.

This warranty does not cover: (a) damage or failure caused by or attributable to acts of God, abuse, accident, misuse, improper or abnormal usage, failure to follow instructions, improper installation or maintenance, alteration, lightning or other incidence of excess voltage or current; (b) any repairs other than those provided by a RadioShack Authorized Service Facility; (c) consumables such as fuses or batteries; (d) cosmetic damage; (e) transportation, shipping or insurance costs; or (f) costs of product removal, installation, set-up service adjustment or reinstallation.

This warranty gives you specific legal rights, and you may also have other rights which vary from state to state.

RadioShack Customer Relations, Dept. W, 100 Throckmorton St., Suite 600, Fort Worth, TX 76102

We Service What We Sell

3/97

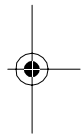
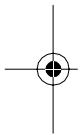

RadioShack
A Division of Tandy Corporation
Fort Worth, Texas 76102

6A8

Printed in China

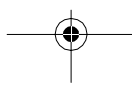

Free Manuals Download Website

<http://myh66.com>

<http://usermanuals.us>

<http://www.somanuals.com>

<http://www.4manuals.cc>

<http://www.manual-lib.com>

<http://www.404manual.com>

<http://www.luxmanual.com>

<http://aubethermostatmanual.com>

Golf course search by state

<http://golfingnear.com>

Email search by domain

<http://emailbydomain.com>

Auto manuals search

<http://auto.somanuals.com>

TV manuals search

<http://tv.somanuals.com>