

## SEMS™

### SCOTT ELECTRONIC MANAGEMENT SYSTEM PDA–PERSONAL DISTRESS ALARM AND PDR–PERSONAL DISTRESS RECEIVER USER ACCOUNTABILITY SYSTEM AND PERSONAL DISTRESS ALARM FOR THE SCOTT AIR-PAK® 2.2 / 3.0 / 4.5 / FIFTY SELF-CONTAINED BREATHING APPARATUS



#### **WARNING**

THE SCOTT SEMS USER ACCOUNTABILITY SYSTEM IS INTENDED FOR USE WITH SCOTT SELF-CONTAINED BREATHING APPARATUS (SCBA) WHICH MAY SUPPORT HUMAN LIFE IN HAZARDOUS ATMOSPHERES. FAILURE TO CAREFULLY READ AND UNDERSTAND THE FOLLOWING INSTRUCTIONS MAY RESULT IN SERIOUS INJURY OR DEATH TO THE SCBA USER.

USE OF A RESPIRATOR INTEGRATED WITH THE SEMS USER ACCOUNTABILITY SYSTEM WILL REQUIRE MODIFICATION OF THE RESPIRATOR "REGULAR OPERATIONAL INSPECTION PROCEDURES" AND WILL REQUIRE TRAINING OF THE RESPIRATOR USER IN THE USE OF SUCH RESPIRATORS.

THE FOLLOWING INSTRUCTIONS SUPPLEMENT BUT DO NOT REPLACE THE OPERATING AND MAINTENANCE INSTRUCTIONS SUPPLIED WITH EACH RESPIRATOR.

## WARNING

READ AND UNDERSTAND THIS COMPLETE INSTRUCTION MANUAL BEFORE USING A RESPIRATOR EQUIPPED WITH A SEMS ACCOUNTABILITY SYSTEM. FAILURE TO USE THE SEMS ACCOUNTABILITY SYSTEM IN ACCORDANCE WITH THESE INSTRUCTIONS MAY LEAD TO CIRCUMSTANCES WHICH COULD RESULT IN SERIOUS INJURY OR DEATH.

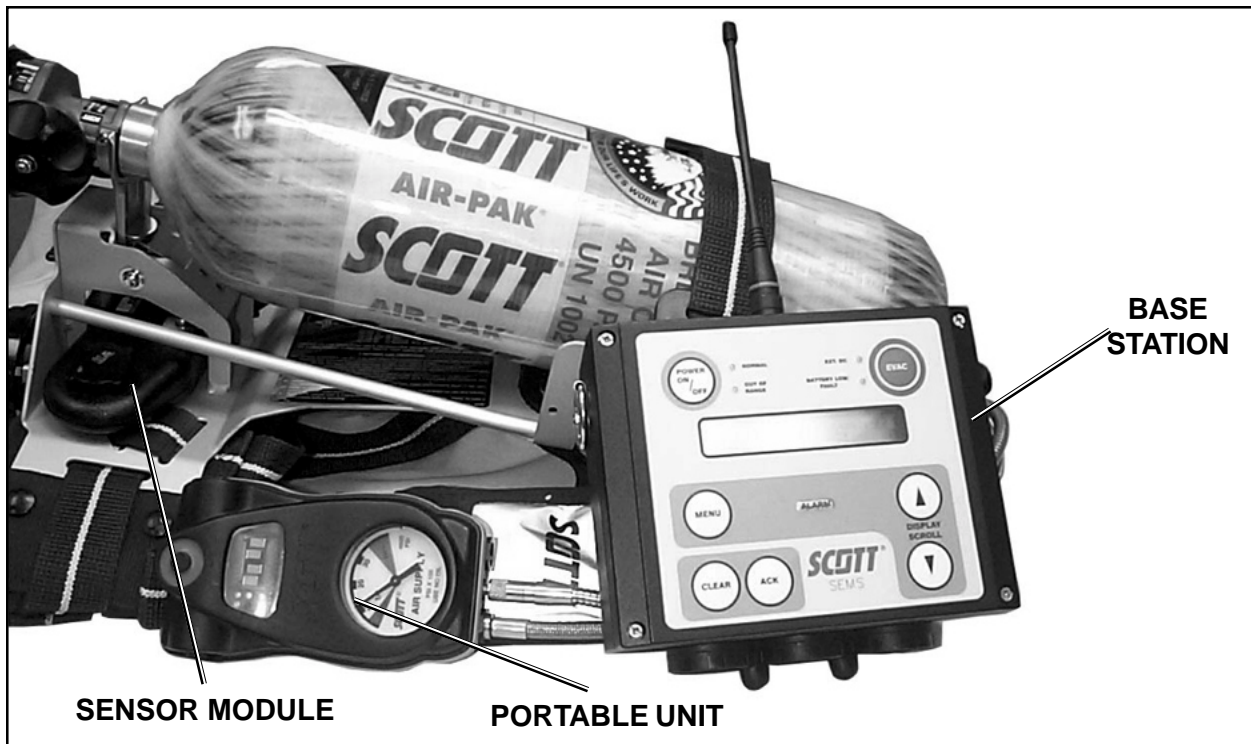

FIGURE 1

## DESCRIPTION

The SCOTT Electronic Management System (SEMS) provides a method of communication between respirator users in a hazardous area and a designated person outside of the hazardous area. The SCOTT SEMS PDA Personal Distress Alarm is an optional accessory which is intended to be integrated only with SCOTT AIR-PAK® 2.2 / 3.0 / 4.5 / Fifty self-contained breathing apparatus (SCBA). The SEMS equipment consists of individual SEMS PDA Portable Units with Control Console attached to the SCOTT AIR-PAK self-contained breathing apparatus and a SEMS PDR Personal Distress Receiver Base Station. The equipment can transmit and receive specific information between the respirator users and the Base Station operator. The specific information consists of user identification and status as well as alerts for evacuation. Complete training in the use of the SEMS equipment is required before actual use in a hazardous environment.

The SEMS PDA Control Console is integrated into the SCOTT AIR-PAK SCBA as a part of the remote air pressure gauge which hangs over the right shoulder of the respirator user. The Control Console also operates the PERSONAL ALERT SAFETY SYSTEM (PASS) distress alarm intended to assist in locating a respirator user who is incapacitated or in need of assistance. The Control Console has a set of status lights, a four character digital display, a dial air pressure gauge, and three control buttons which can easily be pressed with gloved hands. Power is supplied by batteries in both the Control Console and in the SEMS PDA distress alarm battery compartment on the SCBA backframe.

## NOTE

USE ONLY IN ACCORDANCE WITH NFPA 1500, "STANDARD ON FIRE DEPARTMENT OCCUPATIONAL SAFETY AND HEALTH PROGRAM."

The SEMS PDA distress alarm warns the user when the air supply cylinder has reached 50% of its full capacity and also functions as an electronic end of service time indicator for the respirator by sounding an alarm when the air supply cylinder has been depleted to 25% of its full capacity. The Control Console digital display shows the approximate cylinder pressure. Details of the end of service time indicator operation are also discussed in the Operation and Maintenance instructions provided with the respirator.

The SEMS PDR Base Station is a compact battery operated device that can be tripod mounted or carried by a strap. A digital display provides information about status of the respirator users who are logged onto the Base Station. Simple dedicated function buttons control the transmission and receipt of signals with the respirator users. The Base Station can be easily interfaced with a computer for programming and advanced applications.

When a respirator user opens the cylinder valve and begins use of an AIR-PAK SCBA equipped with the SEMS PDA, the Portable Unit will automatically begin to operate. If the SEMS PDR Base Station is present at time of entry, the SEMS PDA must log-in with the Base Station before entry into the hazardous area. Contact between the SEMS PDA Portable Unit and the Base Station will continue until the respirator user terminates use of the SCBA.

Each installation of SEMS equipment operates as a distinct set of Portable Units and Base Station that transmit and receive on a single frequency. If another installation of SEMS equipment is used in the same area, the operation of each group will remain discreet and separate between Portable Units and Base Stations. The SEMS equipment operates between 453.0375 and 465.6375 MHz on radio channels defined in FCC Title 47 (Telecommunications) Part 90 section 20, Limitation (27) and requirement Part 90.238. Programming of the Portable Units and Base Station is essential and must be performed prior to training and use. See SEMS Programming Guide, SCOTT P/N 89506-01 for complete details of programming the SEMS equipment.

The installation of the SCOTT SEMS PDA distress alarm is approved by the National Institute of Occupational Safety and Health (NIOSH) on all models of SCOTT AIR-PAK 2.2 / 3.0 / 4.5 / *Fifty* SCBA.

The SCOTT SEMS PDA distress alarm Portable Unit, when added to a SCOTT Air-Pak respirator, as shown in FIGURE XX, consists of a Sensor Module with battery compartment mounted to the bottom of the respirator backframe, a pressure gauge with transducer, and a Control Console mounted on the wearer's right shoulder strap at the pressure gauge location. The SEMS PDA Portable Unit requires three (3) nine volt batteries to operate: two in the Sensor Module on the backframe and one in the Control Console.

Installation of the SCOTT SEMS PDA distress alarm requires some disassembly of the respirator and should only be performed by an authorized service center. Contact SCOTT HEALTH AND SAFETY, Monroe, NC at 1-800-247-7257 for details.

## **WARNING**

**NO PERSONAL ALERT SAFETY SYSTEM, RESPIRATOR OR COMBINATION OF PERSONAL ALERT SAFETY SYSTEM AND RESPIRATOR, BY THEMSELVES, CAN PROVIDE COMPLETE PROTECTION IN FIRE SITUATIONS. HOWEVER, USING AN ALARM AND A RESPIRATOR IN ACCORDANCE WITH THE REQUIREMENTS OF AN ORGANIZED RESPIRATORY PROTECTION PROGRAM IS ONE OF THE MANY SAFETY PRECAUTIONS WHICH SHOULD BE TAKEN TO AVOID PERSONAL INJURY OR DEATH.**

## **DETECTING AND AVOIDING**

### **RADIO FREQUENCY INTERFERENCE:**

When any electronic device is adversely affected by radio waves, Radio Frequency Interference (RFI) is said to have occurred. All electronic devices like the SEMS PDA distress alarm may be subject to the effects of RFI. Radio transmissions from the antennas of radios including those used by fire fighters, police and other public safety related personnel may produce RFI in the SEMS PDA distress alarm. RFI may occur while the radio is transmitting if the respirator equipped with the SEMS PDA distress alarm is in close proximity to a base station or high-powered vehicle mounted radio, or if the antenna of a personal portable hand held radio is touching or within six (6) inches of the Control Console or Sensor Module of the SEMS PDA distress alarm (See FIGURE 4).

Be aware of the symptoms of RFI. A SEMS PDA distress alarm affected by RFI may temporarily give false indications such as the sudden sounding of the loud continuous three-tone chirp of the full alarm. In some instances the lights on the Control Console may flash without sounding the alarm. In rare circumstances, an alarm which was sounding may stop.

If the SEMS PDA exhibits any of the symptoms of RFI, identify the source of the RFI and do the following:

- If the symptoms of RFI occur when standing near a base station transmitting antenna or a truck mounted radio antenna, move away from the antenna until the symptoms stop.
- If the symptoms of RFI occur while transmitting on a hand-held radio, move the radio away from the SEMS PDA.

**CHECK THE CONTROL CONSOLE AND BE CERTAIN THE GREEN LIGHT IS FLASHING NORMALLY WHEN THE INTERFERENCE STOPS, REGARDLESS OF THE SOURCE.**

In normal usage with the air cylinder open, the SEMS PDA distress alarm will typically resume normal operation after experiencing RFI.

In some circumstances after experiencing RFI, it may be necessary to remove the unit from service. Remove and reinstall the battery to reset the unit (see BATTERY REPLACEMENT section of this instruction). Then inspect and return the unit to service.

### **WARNING**

**KEEP THE ANTENNAS OF HAND-HELD RADIOS AT LEAST SIX (6) INCHES AWAY FROM THE CONTROL CONSOLE AND THE SENSOR MODULE OF THE SEMS PDA DISTRESS ALARM WHEN TRANSMITTING. Close proximity of RADIO EQUIPMENT to the SEMS PDA DISTRESS ALARM during radio transmission may cause the unit to MALFUNCTION. FAILURE TO RECOGNIZE A MALFUNCTION OF THE SEMS PDA DISTRESS ALARM AND TAKE THE PROPER CORRECTIVE ACTION MAY RESULT A NONWORKING DISTRESS ALARM WHICH WILL NOT SOUND IF THE USER STOPS MOVING AND LEAD TO SERIOUS INJURY OR DEATH.**

### **WARNING**

**USERS OF RESPIRATORS EQUIPPED WITH THE SEMS PORTABLE UNIT MUST BE AWARE OF THE PROPER OPERATION OF THE EQUIPMENT. FAILURE TO RECOGNIZE A MALFUNCTION OF THE SEMS PORTABLE UNIT AND TAKE PROPER CORRECTIVE ACTION MAY RESULT IN SERIOUS INJURY OR DEATH.**

If the SEMS PDA distress alarm is affected by RFI when the respirator air supply is turned off or the cylinder is empty, the distress alarm could be turned off during use. If this occurs, depress the RED Manual Alarm Button and hold at least two seconds to activate the alarm.

IF THE SYMPTOMS OF RFI OCCUR, THE RESPIRATOR USER MUST CHECK THE SEMS PDA DISTRESS ALARM TO VERIFY THAT IT IS FUNCTIONING PROPERLY. IF THE GREEN LIGHT ON THE CONTROL CONSOLE DOES NOT RESUME FLASHING IN THE NORMAL MANNER AFTER EXPERIENCING THE SYMPTOMS OF RFI, OR IF THE UNIT CONTINUES TO MALFUNCTION IN ANY OTHER WAY, PROCEED TO A SAFE AREA, REMOVE THE RESPIRATOR FROM SERVICE AND TAG FOR REPAIR BY AUTHORIZED PERSONNEL.

Minimize or eliminate the effects of RFI by protecting the SEMS PDA with the following steps:

- Maintain a safe distance from a base station transmitting antenna or a truck mounted radio antenna.
- Keep the antennas of hand held radios at least six (6) inches away from the CONTROL CONSOLE or the SENSOR MODULE (See FIGURE 2).

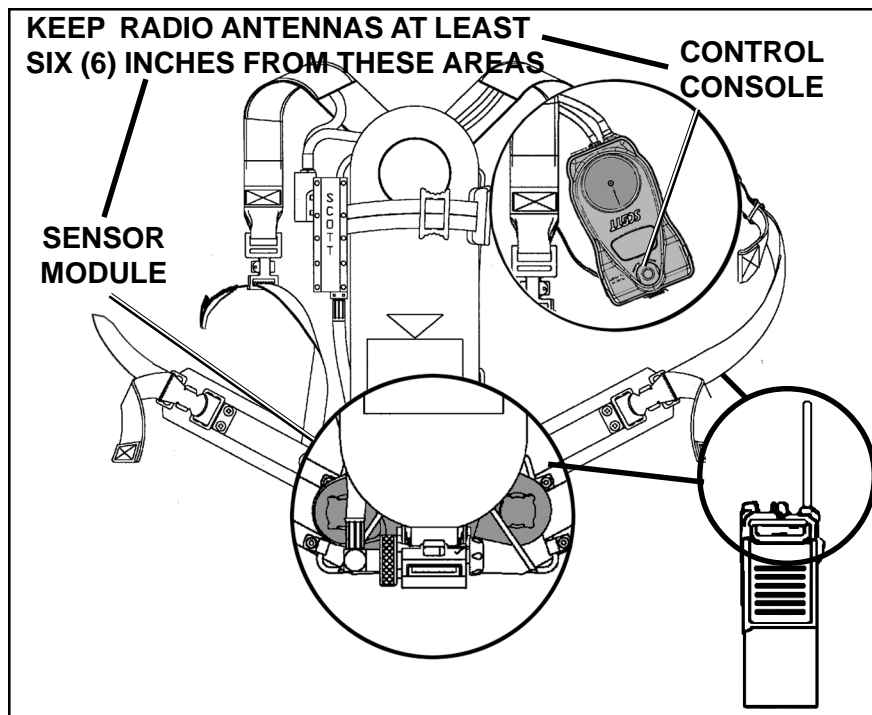

**FIGURE 2**  
**RFI WARNING AREAS**

### **WARNING**

BE AWARE OF THE POTENTIAL EFFECT OF RADIO TRANSMISSIONS FROM BASE STATION OR TRUCK MOUNT RADIOS WHEN USING A RESPIRATOR WITH THE SEMS PDA DISTRESS ALARM. Close proximity of RADIO EQUIPMENT to the SEMS PDA DISTRESS ALARM during radio transmission may cause the unit to MALFUNCTION. FAILURE TO RECOGNIZE A MALFUNCTION OF THE SEMS PDA DISTRESS ALARM AND TAKE THE PROPER CORRECTIVE ACTION MAY RESULT A NONWORKING DISTRESS ALARM WHICH WILL NOT SOUND IF THE USER STOPS MOVING AND LEAD TO SERIOUS INJURY OR DEATH.

## **FCC NOTICE**

This equipment has been tested and found to comply with the requirements of United States Federal Communications Commission, Code of Federal Regulations, FCC title 47, part 90 Section 20, limitation (27) and requirement Part 90.238 over frequency range 453.0375 to 465.6375 MHz, as well as FCC Section 1.1310 for Occupational/Controlled Exposure limits.

If the SEMS Base Station or Portable Unit has been damaged, DO NOT use this equipment. Maintenance or repair of this equipment must only be performed by an authorized SCOTT service center. Unauthorized service may void the manufacturers warranty and may cause damage to the equipment. Use only Scott authorized accessories, cables, and power connectors. Consult the operating and service manuals for instructions on battery replacement, battery maintenance, and use of accessory cables.

### **RADIO FREQUENCY INTERFERENCE (RFI)**

When any electronic device is adversely affected by radio waves, Radio Frequency Interference (RFI) is said to have occurred. All electronic devices like the SEMS PDA distress alarm may be subject to the effects of RFI, most of which are temporary in nature. Users of the SCOTT AIR-PAK SCBA with the integrated SEMS PDA distress alarm must be familiar with the normal operation of the distress alarm and must also be familiar with how to identify and avoid the effects of RFI (see DETECTING AND AVOIDING RADIO FREQUENCY INTERFERENCE on page 14). If RFI occurs to the SEMS PDA distress alarm, it may be caused by transmissions from two-way radio base stations or high-powered vehicle mounted radios or transmissions from hand-held or personal radios where the radio antenna is touching or very close to (less than 6 inches from) components of the SEMS PDA distress alarm.

### **INTRINSICALLY SAFE LISTING**

The SEMS PDA distress alarm, when installed on a SCOTT respirator, is listed as intrinsically safe in Class I Division 1 Groups A, B, C and D hazardous locations by Entela Testing Laboratories. To maintain Intrinsic Safe Listing, the respirator with SEMS PDA distress alarm must be inspected regularly per the following Regular Operational Inspection procedures. SEMS PDA distress alarm components must not be tampered with in any manner. Only batteries of the type indicated on the Sensor Module label and in the Battery Replacement instructions may be installed. The battery compartments must only be opened in an area known to be free of flammable or explosive hazards.

### **PROGRAMMING**

Before SEMS equipment can be put into service, the Base Station and each Portable Unit must be programmed to work with each other. The amount and detail of the information programmed in will depend on the requirements of the organization using the SEMS. At a minimum, the equipment must be setup so that the Base Station will recognize each Portable Unit in the group and associate an identity of the respirator user with the Portable Unit. In this way, specific users who have entered a particular region of the hazardous area can be contacted individually to evacuate to a safe atmosphere. In addition, if a Portable Unit transmits a DISTRESS SIGNAL, the Base Unit will display the identity of the respirator user. See SEMS Programming Guide, SCOTT P/N 89506-01 for complete details of programming the SEMS equipment.

## **WARNING**

**RADIO FREQUENCY INTERFERENCE (RFI) MAY CAUSE A MALFUNCTION OF THE SEMS PDA DISTRESS ALARM. USERS OF RESPIRATORS EQUIPPED WITH THE SEMS PDA DISTRESS ALARM MUST BE AWARE OF THE PROPER OPERATION OF THE DISTRESS ALARM. FAILURE TO RECOGNIZE A MALFUNCTION OF THE SEMS PDA DISTRESS ALARM AND TAKE PROPER CORRECTIVE ACTION MAY RESULT IN SERIOUS INJURY OR DEATH.**

## BASIC FUNCTIONS OF THE SEMS EQUIPMENT

The SEMS equipment has two primary functions:

- Personal Alert Safety System (PASS) Distress Alarm
  - Evacuation Signal
1. The PASS Distress Alarm is joined to the SEMS PDA distress alarm operation. The Portable Unit will send a signal to the Base Station when the SEMS PDA distress alarm goes into full alarm. Activation of the full alarm can be either by manual activation of the user or by automatic activation from lack of user movement for the time period set on the SEMS PDA distress alarm. Once acknowledged by the Base Station operator, "PASS" will appear on the Control Console display.
  2. The Evacuation Signal is sent from the Base Station to the SEMS PDA Portable Unit. It can be handled one of two ways:
    - a) All-Call Signal: The Base Station will send a signal to all SEMS PDA Portable Units logged on to it. When received, the Control Console will display "EVAC" and sound an audible signal. Every respirator user must acknowledge this signal by pressing *twice* the RESET button on the Control Console. Display will continue to read "EVAC" until user leaves hazardous area and shuts down the respirator.
    - b) Selective Evacuation Alarm The Base Station will send a signal to only one individual unit logged on to it. When received, the Control Console will display "EVAC" and sound an audible alarm. The selected respirator user must acknowledge this signal by pressing *twice* the RESET button on the Control Console. Display will continue to read "EVAC" until user leaves hazardous area and shuts down the respirator.

Other additional functions include:

1. The Contact Signal is an automatic signal sent by the Base Station to every Portable Unit that is logged in to the Base Station. Any respirator user who does not return an acknowledgment to the Contact Signal within 120 seconds will be shown on the Base Station as "OUT OF RANGE."
2. Air supply cylinder levels are monitored by the Portable Unit and the Base Station. The user can press and hold the RESET button at any time for a digital display of the remaining air supply cylinder pressure. The approximate cylinder pressure is displayed. The user receives a "½ AIR" warning in the display with an audible alarm when the cylinder reaches one-half of full pressure. The user also receives a "LOW AIR" warning in the display with an audible alarm when the cylinder reaches one quarter of full pressure. The "LOW AIR" warning is also transmitted to the Base Station. The "LOW AIR" alarm will continue to operate until the respirator is shut down.
3. Users can inform the Base Station that they are withdrawing from the hazardous atmosphere by pressing and holding the "WITHDRAW" button on the Control Console for at least two seconds. The display will read "W-D" until the user leaves the hazardous area and shuts down the respirator.

## OPERATION OF THE SEMS PDA DISTRESS ALARM

With proper batteries installed and a charged air cylinder, the SEMS PDA distress alarm (PASS) is automatically activated when the respirator is pressurized by opening the cylinder valve of the respirator. If batteries are completely discharged or have not been installed, there will be no light or sound indicating that the unit will not work at all.

Activation is indicated by 3 quick audible chirps from the Sensor Module. On activation, a green light located on the Control Console, shown in FIGURE 3, will begin to flash approximately once a second. The SEMS PDA distress alarm is now in the automatic mode.

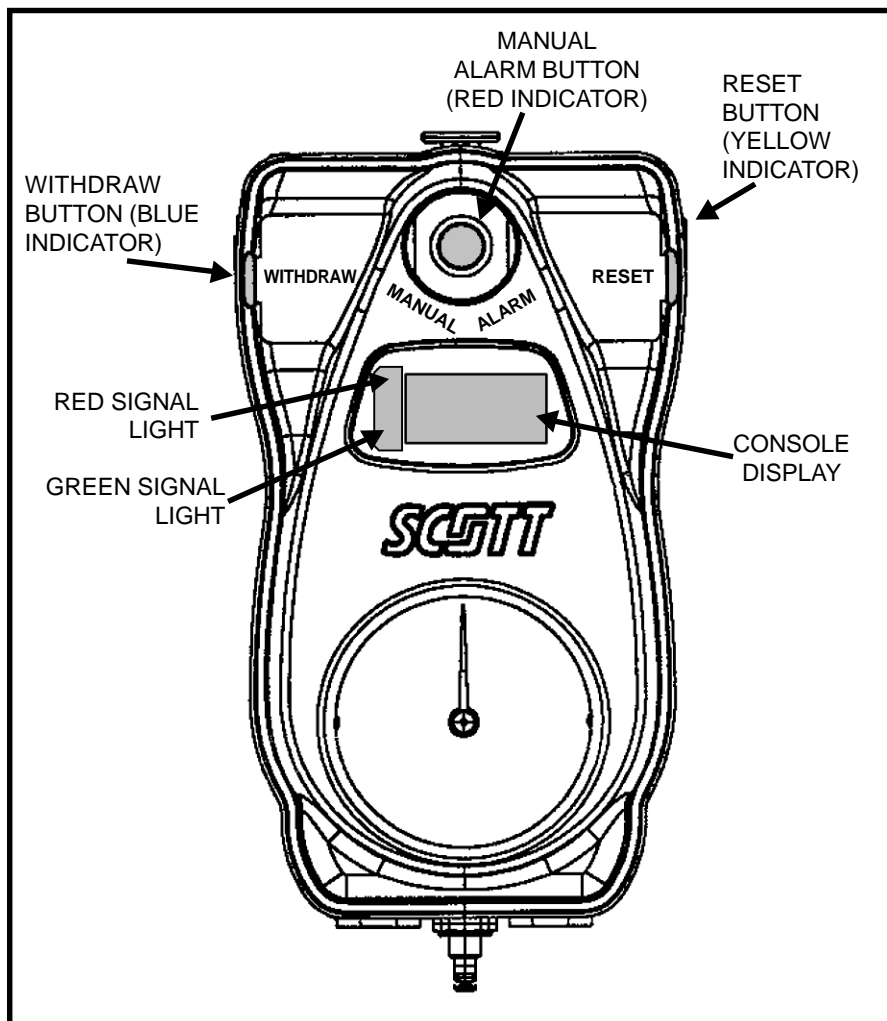

**FIGURE 3**  
**THE PORTABLE UNIT**

If any of the batteries needs replacement, the SEMS PDA distress alarm will indicate as follows:

- **SENSOR MODULE** – A single audible chirp from the Sensor Module once every 2 seconds and the green light on the control module will not flash.
- **CONTROL CONSOLE** – “BATT” will appear in the display but all other functions will operate normally.

If any low battery condition appears at start-up, immediately change all the batteries before use of the respirator. See the BATTERY REPLACEMENT section of this instruction. If a low battery condition appears while the respirator is in use, the SEMS PDA distress alarm will continue to operate for a period of time greater than the longest duration cylinder available for the respirator.

### WARNING

THE SEMS PDA DISTRESS ALARM IS INTENDED TO ASSIST IN LOCATING A PERSON WHO MAY BE IN A LIFE THREATENING SITUATION. FAILURE TO FOLLOW THE INSTRUCTIONS FOR OPENING, CHANGING ALL BATTERIES AND RE-CLOSING BOTH BATTERY COMPARTMENTS MAY RESULT IN DAMAGE WHICH COULD CAUSE FAILURE OF THE PASS DURING A LIFE THREATENING EMERGENCY OR COULD CAUSE A FIRE OR EXPLOSION IN A FLAMMABLE OR EXPLOSIVE ATMOSPHERE POSSIBLY RESULTING IN SERIOUS INJURY OR DEATH.

### WARNING

USERS OF RESPIRATORS EQUIPPED WITH THE SEMS PDA DISTRESS ALARM MUST BE AWARE OF THE PROPER OPERATION OF THE DISTRESS ALARM. FAILURE TO RECOGNIZE A MALFUNCTION OF THE SEMS PDA DISTRESS ALARM AND TAKE PROPER CORRECTIVE ACTION MAY RESULT IN SERIOUS INJURY OR DEATH.



Once activated, the SCOTT SEMS PDA distress alarm will remain activated until:

1. The respirator air cylinder is turned off with the residual air pressure purged from the regulator

AND

2. The reset button on the control module has been pressed twice.

In the automatic mode the SCOTT SEMS PDA distress alarm constantly monitors motion of the respirator backframe. The motion sensor is located in the Sensor Module along with the audible alarm. If the Sensor Module does not sense motion of the respirator for 20 seconds the SEMS PDA distress alarm will signal a pre-alarm condition. If there is still no motion of the respirator for the next 12 seconds the full alarm will sound.

### **PRE ALARM:**

Once the respirator is pressurized, the SEMS PDA distress alarm will automatically sound a pre-alarm if the respirator remains motionless for more than 20 seconds.

When the pre-alarm occurs, the green flashing lights on the Control Console and backframe are replaced by bright red lights which flash approximately once a second and are accompanied by an ascending/descending audible tone which increases in volume during the pre-alarm cycle.

If the user is not incapacitated or not in need of assistance, the pre-alarm is normally reset by movement of the respirator. When reset, the flashing red lights will be replaced by the flashing green lights and the ascending/descending tone will stop.

A pre-alarm may also be reset by pressing and holding the reset button on the side of the Control Console until three (3) quick audible chirps are heard and the red flashing lights on the Control Console and backframe are replaced by the green flashing lights.

Remember that the motion sensor is in the Sensor Module under the air cylinder valve and not in the Control Console so that actual movement of the respirator backframe is required for reset. Shaking the Control Console will not reset the SEMS PDA distress alarm .

### **FULL ALARM:**

If the user is incapacitated or in need of assistance and can not move, the SEMS PDA distress alarm will go into full alarm 12 seconds after the pre-alarm starts.

Full alarm is indicated by a loud, almost continuous 3 tone chirp from the Sensor Module accompanied by the flashing of the red signal lights on the Control Console and "PASS" will appear in the display. The full alarm condition can only be cleared by manually pressing twice on the reset button, located on the side of the Control Console, shown in FIGURE 3.

After the full alarm has been silenced by pressing the reset button, releasing it and pressing it again, the SEMS PDA distress alarm will remain activated with the green lights flashing once every 2 seconds. In the activated or "automatic" mode, it will again go into pre-alarm followed by full alarm unless there is movement of the respirator at least once every 20 seconds as long as the respirator is pressurized.

### **WARNING**

**USERS OF RESPIRATORS EQUIPPED WITH THE SEMS PDA DISTRESS ALARM MUST BE AWARE OF THE PROPER OPERATION OF THE DISTRESS ALARM. IF THE GREEN LIGHT IS NOT FLASHING NORMALLY, OR IF THE UNIT EXHIBITS ANY OTHER SIGNS OF A MALFUNCTION WITHOUT THE USER TAKING PROPER CORRECTIVE ACTION, IT MAY LEAD TO CIRCUMSTANCES THAT RESULT IN SERIOUS INJURY OR DEATH.**

## **MANUAL ALARM:**

If the respirator user is in a situation where immediate assistance is required, the SEMS PDA distress alarm provides a manual alarm button, located on the front of the Control Console on the user's right shoulder, shown in FIGURE 2.

The manual alarm causes the Full Alarm signal to be given. The manual alarm may be activated at any time by pressing the manual alarm button and holding at least two seconds, even when the respirator is not pressurized, provided a good battery is in the SEMS PDA distress alarm. If the manual alarm button has been pressed without the respirator pressurized, the alarm can be silenced by pressing the reset button twice. The SEMS PDA distress alarm is now on and in automatic mode. To turn the unit off, press the reset twice again while the unit is not in alarm mode.

## **TURNING OFF THE SEMS PDA DISTRESS ALARM:**

The SEMS PDA distress alarm can not be turned off if the respirator cylinder valve is open and/or pressure remains in the respirator. Pressing the reset button when the respirator is pressurized will only reset an alarm condition and return the SEMS PDA distress alarm to automatic mode.

When the use of the SEMS PDA distress alarm and respirator is no longer required, first close the cylinder valve on the respirator, then vent the residual air from the respirator system by opening the regulator purge valve. After waiting until the air flow stops, close the regulator purge valve and turn off the SEMS PDA distress alarm by pressing the reset button twice after the flashing green light sequence. The unit will say "OFF" in the display, sound a quick two tone chirp, and the SEMS PDA distress alarm will be inactive. If there is no pressure in the system when the reset button is pressed twice, there will be no beep sequence.

If the respirator is turned off and depressurized without pressing the reset button twice, the SEMS PDA distress alarm will continue to monitor motion in automatic mode. This means that the SEMS PDA distress alarm may be used to monitor motion after the respirator is turned off and depressurized. Resetting the full alarm after the respirator has been depressurized will not turn off the SEMS PDA distress alarm. The reset switch must be depressed twice after the flashing green light sequence with no alarm condition to turn off the SEMS PDA distress alarm (the display will say "OFF" and two tone chirp should be heard).

Remember, the loud audible alarm and flashing red lights can be turned on at any time by pressing the manual alarm button and holding at least two seconds.

## **WARNING**

**NO PERSONAL ALERT SAFETY SYSTEM, RESPIRATOR OR COMBINATION OF PERSONAL ALERT SAFETY SYSTEM AND RESPIRATOR, BY THEMSELVES, CAN PROVIDE COMPLETE PROTECTION IN FIRE SITUATIONS. HOWEVER, USING AN ALARM AND A RESPIRATOR IN ACCORDANCE WITH THE REQUIREMENTS OF AN ORGANIZED RESPIRATORY PROTECTION PROGRAM IS ONE OF THE MANY SAFETY PRECAUTIONS WHICH SHOULD BE TAKEN TO AVOID PERSONAL INJURY OR DEATH.**

## OTHER OPERATIONAL FEATURES

### END OF SERVICE TIME INDICATOR

The SEMS PDA distress alarm also provides an electronic end of service time indicator and cylinder pressure display as follows:

#### 1/2 full cylinder

When the air supply cylinder has reached 1/2 full capacity, the audible signal will sound and the display will read "1/2 AIR" for 10 seconds.

#### 1/4 full cylinder

When the air supply cylinder has reached 1/4 full capacity, the audible signal will sound and the display will read "LOW AIR" and then flash the remaining cylinder air pressure in psig until the user responds by pressing the RESET button. However, the alarm will continue to repeat actuation until the system is shut down or until the unit detects no movement by the user at which time the SEMS PDA distress alarm sequence will begin with PRE ALARM and FULL ALARM as stated above.

#### Cylinder pressure display

Pressing and holding the RESET at any time will show the approximate cylinder pressure remaining in psig on the display.

### BATTERY TEST

When the SEMS PDA distress alarm is in the off condition (cylinder valve closed with no flashing green lights, the batteries in the Sensor Module can be checked by depressing and holding the reset button on the console.

A green LED will illuminate on the console to indicate sufficient battery power remaining; a red light indicates that the batteries must be replaced before the respirator is to be used again.

### WARNING

THE RESPIRATOR USER MUST IMMEDIATELY LEAVE THE AREA REQUIRING RESPIRATORY PROTECTION WHEN AN END OF SERVICE INDICATOR ALARM ACTUATES. ACTUATION OF AN END OF SERVICE INDICATOR ALARM WARNS THAT APPROXIMATELY 25% OF FULL PRESSURE REMAINS IN THE AIR SUPPLY CYLINDER (THAT IS, APPROXIMATELY 3/4 OF THE TOTAL AIR SUPPLY HAS BEEN USED). A DELAY IN LEAVING THE AREA AFTER ALARM ACTUATION MAY RESULT IN SERIOUS INJURY OR DEATH.

### WARNING

FAILURE TO REPLACE THE BATTERIES AND/OR CONTINUING WITH MULTIPLE USES OF THE RESPIRATOR AFTER THE LOW BATTERY CONDITION HAS BEEN INDICATED BY THE SEMS PDA DISTRESS ALARM MAY RESULT IN FAILURE OF THE SEMS PDA DISTRESS ALARM DURING USE AND POSSIBLE INJURY OR DEATH OF THE USER.

## USE OF THE SEMS PDA PORTABLE UNIT

Users of SCOTT respirators equipped with the SEMS PDA Portable Unit must be fully trained in the operation of the equipment as part of a complete respiratory protection program before entering a hazardous environment.

### 1. Start-up

- a) Use of the SEMS PDA Portable Unit begins when the user opens the cylinder valve on the respirator to start respirator usage. The unit will sound three chirps to indicate activation.
- b) After a brief start-up sequence of less than ten seconds, the green light in the Control Console and the display will show “<<<<” until the unit is acknowledged and logged onto a base station. An alert tone, a “BE-doop” to indicate the system activity, is used for several functions. Whenever the alert tone occurs, the user should look at the Portable Unit display for information.

### 2. Initialization and Range

- a) After the start-up sequence, the SEMS PDA Portable Unit will send an Initialization signal to the Base Station to log in. The Base Station will respond by showing “ACK” for the identity assigned to that Portable Unit.
- b) If the respirator user moves too far from the Base Station after logging-in, the Control Console will begin to display “RNGE” indicating out of range until the user moves back into the Base Station field of operation (up to one-half mile line-of-sight).
- c) If the Portable Unit is too far away from the Base Station at start-up, or if the Base Station is not powered up, the Control Console display will read “RNGE” right from start-up and not be logged into the Base Station. The SEMS PDA Portable Unit will continue trying to log-in to a Base Station until one comes into range or is powered up.
- d) Except for those functions which involve communication with the Base Station, all other functions of the Control Console and SEMS PDA distress alarm are still operational when the Portable Unit is either out of range or not logged into a Base Station.

### 3. Air Supply Cylinder Pressure

- a) To check the air supply cylinder pressure, the user must press and hold the RESET button on the Control Console. The approximate pressure remaining in the cylinder will be shown in the display as PSIG.
- b) When the cylinder reaches one-half of full pressure, the Control Console will display “1/2 AIR” for ten seconds.
- c) When the cylinder reaches one-quarter of full pressure, the Control Console will display “LOW AIR”. A low air signal will be sent to the Base Station within ten seconds. The Base Station operator must press “ACK” on the Base Station to acknowledge the user’s low air signal.

## WARNING

**USERS OF RESPIRATORS EQUIPPED WITH THE SEMS PDA DISTRESS ALARM MUST BE AWARE OF THE PROPER OPERATION OF THE DISTRESS ALARM. FAILURE TO RECOGNIZE A MALFUNCTION OF THE SEMS PDA DISTRESS ALARM AND TAKE PROPER CORRECTIVE ACTION MAY RESULT IN SERIOUS INJURY OR DEATH.**

4. Distress Alarm
  - a) If the user is in distress or becomes immobile, the SEMS PDA distress alarm will operate in conjunction with the Portable Unit. If the distress alarm is activated, either by the user pressing and holding the MANUAL ALARM for at least two seconds, or from the user being immobile for the required time duration, the Portable Unit will send a distress signal to the Base Station. The distress alarm will override all other messages and actions of the Portable Unit.
  - b) When the Base Station acknowledges the user's distress signal by pressing the "ACK" button on the Base Station, the Control Console will respond by displaying "PASS" and continuing to sound the distress alarm on the respirator. The distress alarm will continue until the user shuts down the respirator.
5. Evacuation
  - a) If the respirator users are required to leave the hazardous area, the Base Station operator can send an evacuation message to the Portable Units of logged-in respirator users. This message can be sent either to all logged-in users or to selected logged-in users as chosen from the list on the Base Station.
  - b) The Portable Unit will emit the alert sound and "EVAC" will appear flashing in the Control Console display.
  - c) When an "EVAC" message appears on the Control Console display, the respirator user must press *twice* the RESET button on the Control Console to respond to the evacuation message. "EVAC" will continue to appear in the display of the Control Console until the user leaves the hazardous area and shuts down the respirator.
6. Withdraw
  - a) The respirator user may choose to leave the hazardous area. Pressing and holding the WITHDRAW button on the Control Console will send that message to the Base Station.
  - b) When the Base Station receives a user withdrawal message, the operator presses the "ACK" button on the Base Station to respond.
  - c) When the Portable Unit receives the acknowledgment response, the Control Console will display "W-D" until the respirator user leaves the hazardous area and shuts down the respirator.
7. Shutdown
  - a) After leaving the hazardous area and confirming that respirator use is no longer required, doff the respirator according the user instructions provided with the respirator.
  - b) Close the cylinder valve.
  - c) Press the RESET button twice.
  - d) The Control Console will sound the alert tone and flash "OFF" in the display. The Portable Unit is now off.
8. Batteries

Battery operation is as stated in the SEMS PDA distress alarm section of this instruction.

#### **WARNING**

**IF THE LOW BATTERY INDICATION OCCURS AT ANY TIME DURING USE OF THE RESPIRATOR, THE BATTERIES MUST BE CHANGED BEFORE THE NEXT USE OF THE RESPIRATOR. USE OF A RESPIRATOR WITH DEPLETED BATTERIES MAY LEAD TO A FAILURE OF THE RESPIRATOR WHICH COULD RESULT IN SERIOUS INJURY OR DEATH.**

## USE OF THE SEMS BASE STATION

The SEMS PDR Base Station must be properly programmed before field use. See SEMS Programming Guide SCOTT P/N 89506-01 for complete details of SEMS programming.

The SEMS PDR Base Station requires batteries for operation. See the BATTERY REPLACEMENT section of this instruction. An optional external power supply is available.

The SEMS PDR Base Station must be operated by a fully trained individual as part of a complete respiratory protection program. The Base Station operator must have the ability to direct rescue operations as needed.

1. Start-up
  - a) Press the POWER button on the Base Station to begin operation.
  - b) All Portable Units that were initialized before the Base Station was powered up will be logged-in as indicated by "ACK" registered with the user's identity.
  - c) Any Portable Units initialized after the Base Station is powered up will also be logged-in as indicated by "ACK" registered with the user's identity.
  - d) The base station tracks the time for each Portable Unit from log-in until each respirator user leaves the hazardous area and shuts down their respirator.

## WARNING

THE SEMS BASE STATION MUST BE MONITORED BY A FULLY TRAINED INDIVIDUAL WITH THE ABILITY TO DIRECT RESCUE OPERATIONS AT ALL TIMES WHEN LOGGED-IN RESPIRATOR USERS MAY BE IN A HAZARDOUS AREA. FAILURE TO PROVIDE A PROPERLY TRAINED BASE STATION OPERATOR MAY PERMIT A SITUATION TO OCCUR WHICH COULD RESULT IN SERIOUS INJURY OR DEATH.

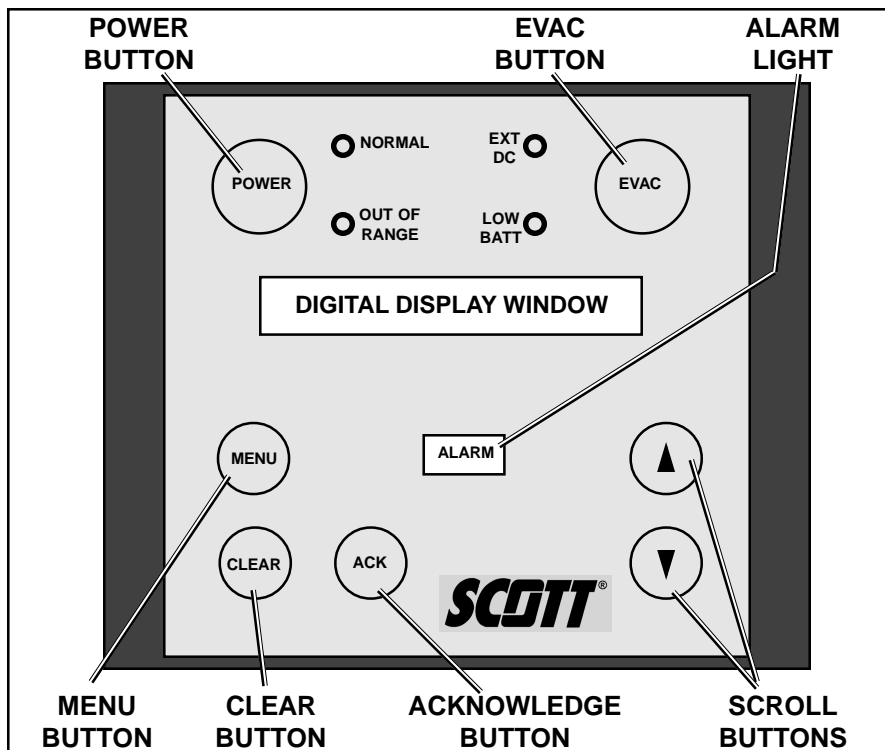

FIGURE 4  
BASE STATION

## 2. Evacuation

- a) To send an evacuation message to all logged-in respirator users, the Base Station operator must press and hold the "EVAC" button on the Base Station and then choose "ALL-CALL" from the menu on the display. The "EVAC" message will be sent to all logged-in respirator users.
- b) To send an evacuation message to only selected respirator users, the Base Station operator uses the scroll buttons to move up and down the list of logged-in respirator users and presses the "EVAC" button when the selected users are highlighted in the display.
- c) The respirator users who receive the "EVAC" message must press the RESET button on the Control Console to acknowledge the message.
- d) The Base Station listing of logged-in users will display "CONF" with each respirator user who has responded to the "EVAC" message.

## 3. Air Supply Monitoring

- a) When the air supply cylinder reaches one-quarter of full pressure, the alert sound will occur and the Control Console will display "LOW AIR". A low air signal will be sent to the Base Station within ten seconds. This end of service time indicator (EOSTI) alarm cannot be silenced by the user until the user leaves the hazardous area and shuts down the respirator.
- b) The Base Station operator must press "ACK" on the Base Station to acknowledge the user's low air signal.

## EVENT LOG

Software within the Base Station maintains a data record or EVENT LOG of each communication to or from the Base Station from the time it is powered for use until it is powered down. To access and use the EVENT LOG, proceed as follows:

### BASE UNIT INTERFACE SETUP

Plug the Base Unit Interface Cable into a COM port as instructed in the COMPUTER SETUP section the SEMS Programming Instructions SCOTT P/N 89506-01.

1. Plug the other end of the Base Unit Interface Cable into the connector on the side of the Base Unit.
2. Run the SEMS Fire Department Software and select the tab labeled "EVENT LOG." See FIGURE 5.

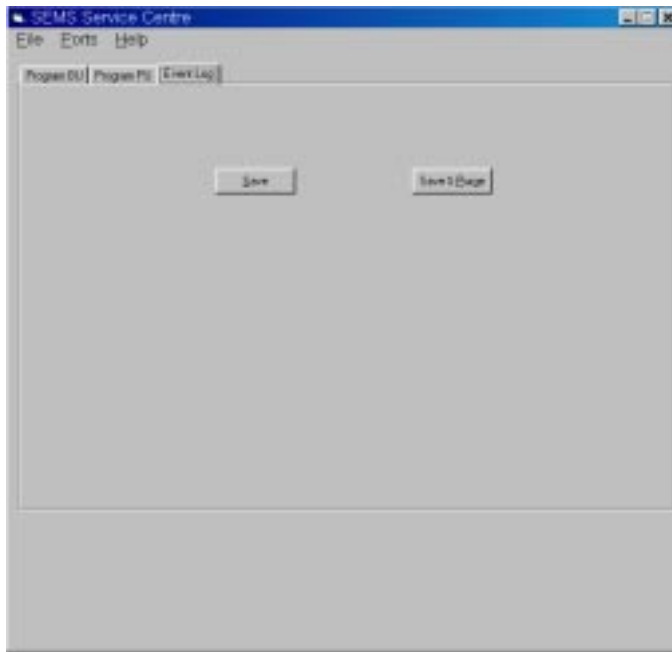

**FIGURE 5**  
**EVENT LOG SCREEN**

3. On the Base Unit, press and hold the EVAC button while turning on the unit by pressing the POWER ON/OFF button. Continue holding the EVAC button until the screen displays, "COMMAND MODE: CS =0X2A58". (NOTE: CS number may vary depending on version of Base Unit.)
4. Choose either "SAVE" or "SAVE & PURGE" to save the information in the EVENT LOG. The data will be saved as a text (.txt) file to a folder called "Event Logs" in the same folder where the SEMS Fire Department Software resides on your computer [e.g.:(drive)\Program Files\SEMS Service Center\Event Logs\{folder}].
  - a) "SAVE" will save the EVENT LOG file to the Event Logs folder but leaves the EVENT LOG information on the Base Unit.
  - b) "SAVE & PURGE" will save the EVENT LOG file to the Event Logs folder and then erase the EVENT LOG information from the Base Unit.



5. The EVENT LOG file is a text (.txt) which may be viewed in either Microsoft Excel or Microsoft Word. The data is in columns separated (delimited) by commas. It may require some manipulation of the columns to facilitate reading as shown in FIGURE 6. The columns contain information as follows:

- Column 1 Event number Identification
- Column 2 Date of Event
- Column 3 Time of Event
- Column 4 Fire Company (blank if the PDA and the Base Unit have the same name.)
- Column 5 Truck Number
- Column 6 Seat Number or Position
- Column 7 Event (LOGON, PASS, ACK, etc.)
- Column 8 Cylinder Pressure at time of Event
- Column 9 Total time the AIR-PAK respirator had been on at time of Event

ID	Date	Time	Brigade	Truck	Posn	State	Press	El. Time
1	06/02/03	14:22:32	SCOTT	ONE	5	OK	0	1
2	06/02/03	14:22:32	SCOTT	TWO	4	Logon Ack	0	0
3	06/02/03	14:22:36	MULT	LOGNG	1	Logon Ack	0	7
4	06/02/03	14:22:38	MULT	LOGNG	2	Logon Ack	0	7
5	06/02/03	14:22:40	SCOTT	ONE	3	OK	0	1
6	06/02/03	14:22:42	MULT	LOGNG	2	OK	0	7
7	06/02/03	14:22:44	MULT	LOGNG	3	Logon Ack	0	7
8	06/02/03	14:22:48	MULT	LOGNG	3	OK	0	7
9	06/02/03	14:22:48	MULT	LOGNG	4	Logon Ack	0	7
10	06/02/03	14:22:48	MULT	LOGNG	4	OK	0	7
11	06/02/03	14:22:50	SCOTT	TWO	4	OK	0	1
12	06/02/03	14:22:52	MULT	LOGNG	5	Logon Ack	0	7
13	06/02/03	14:22:54	MULT	LOGNG	6	Logon Ack	0	7
14	06/02/03	14:22:58	MULT	LOGNG	7	Logon Ack	0	7
15	06/02/03	14:23:00	SCOTT	TWO	3	OK	0	1
16	06/02/03	14:23:02	MULT	LOGNG	7	OK	0	7
17	06/02/03	14:23:04	MULT	LOGNG	8	Logon Ack	0	8
18	06/02/03	14:23:04	SCOTT	ONE	2	OK	0	2
19	06/02/03	14:23:04	MULT	LOGNG	8	OK	0	8
20	06/02/03	14:23:12	MULT	LOGNG	9	Logon Ack	0	8
21	06/02/03	14:23:40	SCOTT	ONE	4	OK	0	2
22	06/02/03	14:23:42	SCOTT	TWO	1	OK	0	1
23	06/02/03	14:23:42	SCOTT	TWO	2	OK	0	1
24	06/02/03	14:33:52	SCOTT	TWO	4	Pass Unack	0	12
25	06/02/03	14:34:00	SCOTT	ONE	5	Pass Unack	0	13
26	06/02/03	14:34:02	SCOTT	ONE	4	Pass Unack	0	13
27	06/02/03	14:34:04	SCOTT	ONE	2	Pass Unack	0	13
28	06/02/03	14:34:04	SCOTT	TWO	3	Pass Unack	0	12
29	06/02/03	14:34:04	SCOTT	TWO	2	Pass Unack	0	12
30	06/02/03	14:34:08	SCOTT	ONE	3	Pass Unack	0	13
31	06/02/03	14:34:16	SCOTT	ONE	1	Pass Unack	0	13
32	06/02/03	14:34:18	SCOTT	TWO	1	Pass Unack	0	12
33	06/02/03	14:34:28	SCOTT	TWO	4	Pass Ack	0	12
34	06/02/03	14:34:30	SCOTT	TWO	3	Pass Ack	0	12
35	06/02/03	14:34:32	SCOTT	TWO	2	Pass Ack	0	12
36	06/02/03	14:34:34	SCOTT	TWO	1	Pass Ack	0	12
37	06/02/03	14:34:34	SCOTT	ONE	5	Pass Ack	0	13
38	06/02/03	14:34:36	SCOTT	ONE	4	Pass Ack	0	13
39	06/02/03	14:34:38	SCOTT	ONE	3	Pass Ack	0	13
40	06/02/03	14:34:40	SCOTT	ONE	3	FF Down	0	13
41	06/02/03	14:34:40	SCOTT	ONE	4	FF Down	0	13
42	06/02/03	14:34:40	SCOTT	ONE	2	Pass Ack	0	13
43	06/02/03	14:34:40	SCOTT	TWO	1	FF Down	0	12
44	06/02/03	14:34:40	SCOTT	TWO	2	FF Down	0	12
45	06/02/03	14:34:40	SCOTT	TWO	3	FF Down	0	12
46	06/02/03	14:34:42	SCOTT	ONE	1	Pass Ack	0	13
47	06/02/03	14:34:42	SCOTT	ONE	2	FF Down	0	13
48	06/02/03	14:34:48	SCOTT	TWO	4	FF Down	0	12
49	06/02/03	14:35:30	SCOTT	ONE	1	FF Down	0	14
50	06/02/03	14:35:30	SCOTT	ONE	5	FF Down	0	14

**FIGURE 6  
SAMPLE EVENT LOG**

Columns 4, 5, and 6 identify a particular AIR-PAK respirator equipped with the SEMS PDA that has logged on to the Base Unit in the course of the incident. The events include LOGON, PASS activation, Withdrawal, Acknowledgement (ACK) of messages, etc.

## REGULAR OPERATIONAL INSPECTION

When installed on a SCOTT SCBA, inspection and test of the SCOTT SEMS PDA distress alarm is to be conducted along with inspection and test of the respirator before each use. To do this, the REGULAR OPERATIONAL INSPECTION procedures in your respirator instructions will require modification. The instructions below are to be added to the instructions for REGULAR OPERATIONAL INSPECTION of your respirator. If, during the inspection, any malfunction of the respirator or the SEMS PDA distress alarm is noted remove the respirator from service and tag for repair by authorized personnel.

REGULAR OPERATIONAL INSPECTION of the SEMS PDA Portable unit installed on a SCOTT SCBA requires inspection of both the Distress Alarm (PASS) functionality and the Portable Unit interaction with the SEMS PDR Base Station.

Before REGULAR OPERATIONAL INSPECTION, verify that the batteries are fresh and properly installed. Batteries are located in two locations on the SEMS PDA distress alarm Portable Unit. Each location notifies separately when the batteries require replacement:

- As the batteries in the Sensor Module begin to approach the end of their useful life, the Sensor Module will sound a chirp approximately every two seconds, the green lights on the control module will go out.
- When the battery in the Control Console requires changing, "BATT" will appear in the display.

In either condition the SEMS PDA distress alarm will continue to operate normally, going into pre-alarm after 20 seconds with no motion and full alarm after 12 more seconds of no motion.

While in a low battery condition, the SEMS PDA distress alarm will continue to operate for a period of time greater than the longest duration cylinder available for the respirator. However, the batteries must be replaced before the respirator is used again. See BATTERY REPLACEMENT section of these instructions.

## BATTERY TEST

When the SEMS PDA distress alarm is in the off condition (cylinder valve closed with no flashing green lights, the batteries in the Sensor Module can be checked by depressing and holding the reset button on the console.

A green LED will illuminate on the console to indicate sufficient battery power remaining; a red light indicates that the batteries must be replaced before the respirator is to be used again.

## WARNING

FOLLOW REGULAR OPERATIONAL INSPECTION PROCEDURE EXACTLY. IF THE SEMS PDA DISTRESS ALARM DOES NOT ACTUATE, OR DOES NOT OPERATE AS DESCRIBED OR IF ANY OTHER OPERATIONAL MALFUNCTION IS NOTED, DO NOT USE THE RESPIRATOR.

## WARNING

FAILURE TO REPLACE THE BATTERIES AND/OR CONTINUING WITH MULTIPLE USES OF THE SEMS EQUIPMENT AFTER THE LOW BATTERY CONDITION HAS BEEN INDICATED MAY RESULT IN FAILURE OF THE SEMS ACCOUNTABILITY SYSTEM DURING USE WHICH COULD LEAD TO SERIOUS INJURY OR DEATH.

## WARNING

IN SEVERAL OF THE INSPECTION PROCEDURES DESCRIBED A FULL ALARM WILL BE OBSERVED. THE FULL ALARM CONDITION INCLUDES AN AUDIBLE TONE THAT CAN EXCEED 95 dBA AT 3 METERS (9.9 FT.). IN ORDER TO PREVENT POSSIBLE HEARING DAMAGE DURING TEST, THE ALARM SHOULD BE RESET IMMEDIATELY ON VERIFICATION THAT SEMS IS FUNCTIONING PROPERLY. HEARING PROTECTION SHOULD BE WORN IF PROLONGED EXPOSURE TO A FULL ALARM CONDITION IS ANTICIPATED.

## CAUTION

THE PERFORMANCE PROPERTIES OF THE SEMS PDA DISTRESS ALARM CANNOT BE PROPERLY TESTED IN THE FIELD.

## NOTE

IF THIS INSPECTION IS DONE IN DIRECT SUNLIGHT IT MAY BE HELPFUL TO SHADE THE LENS ON THE CONTROL MODULE WITH YOUR HAND TO BE SURE THE GREEN LIGHT IS FLASHING.

## INSPECTION OF SEMS PDA DISTRESS ALARM

1. While performing the visual inspection of the respirator visually inspect all SEMS PDA distress alarm enclosures, lenses, and wire conduits for cracks, wear or other damage. If damage is noted, remove respirator from service and tag respirator for repair by qualified personnel.
2. Before pressurizing the respirator by opening the cylinder valve, check the SEMS PDA distress alarm manual alarm feature by pressing the manual alarm button, located on the front of the Control Console. Press and hold the manual alarm button at least two seconds. The manual alarm shall begin sounding a loud almost continuous 3 tone chirp accompanied by flashing of the red signal light on the Control Console and backframe. Reset the manual alarm by pressing twice on the reset button located on the side of the Control Console (**fully depress reset button, release and press again**). Unit will sound three chirps and green light will flash. Turn the unit off by pressing the reset button twice again. Unit will sound a two tone chirp and green lights will go out.
3. Open the cylinder valve to pressurize the system. The SEMS PDA distress alarm shall sound 3 quick chirps and the lights on the Control Console and backframe shall begin flashing green about once a second. The 3 chirps will sound approximately the same time the VIBRALERT® in the mask mounted regulator actuates briefly.
4. Check pre-alarm: With respirator pressurized but with air flow stopped (with switch depressed on “donning switch” or “E-Z FLO™” regulators or with facepiece held to face on standard models), leave respirator motionless for 20 seconds. The green flashing lights shall be replaced by red flashing lights. An ascending/descending tone will sound increasing in volume.
5. Check pre-alarm reset: With respirator pressurized but with air flow stopped (see step 4 above) leave respirator motionless until pre-alarm condition occurs. Within 12 seconds, move the respirator to activate the Sensor Module. SEMS PDA distress alarm shall reset. The red flashing lights shall be replaced by green flashing lights and the ascending/descending tone shall stop.

Continue with regular operational inspection of respirator as directed by respirator instructions or your approved respiratory protection plan procedure. During the inspection the respirator must be moved or turned every 30 seconds or less to prevent the sounding of the full alarm.

### ***Perform the following checks after completion of all respirator checks and before turning off cylinder valve:***

6. Check manual reset of pre-alarm: With respirator pressurized but with air flow stopped (see step 4 above) leave respirator motionless until pre-alarm condition occurs. Within 12 seconds press and hold reset button. Three (3) chirps shall sound, then release button. The SEMS PDA distress alarm shall reset to the automatic mode and the flashing red lights will be replaced by a flashing green lights.
7. Check full alarm: Again, as in step 6 above, leave respirator motionless until pre-alarm condition occurs. Do not reset. Within 12 seconds a loud, almost continuous 3 tone chirping shall begin, accompanied by the flashing of the red lights on the Control Console and backframe. Display will read “PASS.”

## WARNING

IF THE LOW BATTERY INDICATION (ONE STEADY CHIRP EVERY TWO SECONDS WITH NO FLASHING LIGHTS) OCCURS AT ANY TIME DURING REGULAR OPERATIONAL INSPECTION, DO NOT USE THE RESPIRATOR. CHANGE THE BATTERY IN THE BATTERY COMPARTMENT IMMEDIATELY AND REPEAT THE REGULAR OPERATIONAL TEST OR TAKE THE RESPIRATOR OUT OF SERVICE UNTIL THE BATTERY IS CHANGED AND THE REGULAR OPERATIONAL TEST IS SUCCESSFULLY PERFORMED.

## WARNING

IF THE SEMS PDA DISTRESS ALARM IS USED IN AN AREA OF EXPLOSIVE OR FLAMMABLE HAZARDS, FAILURE TO REGULARLY INSPECT AS INSTRUCTED, FAILURE TO CORRECT DAMAGE BEFORE USE OR THE INSTALLATION OF INCORRECT BATTERY MAY LEAD TO A FIRE OR EXPLOSION WHICH MAY RESULT IN PERSONAL INJURY OR DEATH.

REGULAR OPERATIONAL INSPECTION  
CONTINUED ON NEXT PAGE...

8. Check alarm reset: While in full alarm, fully depress reset button, release, and depress again. The SEMS PDA distress alarm shall reset to the automatic mode. The loud alarm shall stop and the red flashing lights shall be replaced by green flashing lights.
9. Check continuing operation of the SEMS PDA distress alarm: After finishing all respirator checks involving air flow, turn off cylinder valve (push in and turn clockwise), purge all residual pressure in respirator (open purge valve and wait for air flow to stop, close purge valve). The SEMS PDA distress alarm shall remain active with green light flashing. Do not move respirator, pre-alarm shall occur with 20 seconds. Move respirator slightly, pre-alarm shall reset, green lights shall start flashing again.
10. Check operation of end of service time indicator:
  - a) Open cylinder valve again to charge system, then push in and rotate cylinder valve knob clockwise to close.
  - b) When cylinder valve is fully closed, open purge valve slightly to vent residual air pressure from system.
  - c) As the residual air pressure vents from the system, the remote pressure gauge needle will swing from "FULL" and move towards "EMPTY." Close the purge valve when the gauge needle crosses the "1/4" mark but before the beginning of the red "EMPTY" band. The end of service indicator alarms shall actuate along with the SEMS PDA electronic end of service time indicator.
  - d) After verifying that all alarms are functioning (the SEMS PDA electronic end of service time indicator will flash in the display "LOW AIR") open the purge valve slightly to vent the remaining residual air pressure from the system. All alarms shall cease operation when the system pressure drops to zero except the electronic end of service time indicator.
  - e) To terminate the electronic end of service time indicator, press the Reset button on the Control Console twice after the flashing green light sequence. When air flow stops completely, return purge valve to the fully closed position (pointer on knob upward).
11. Turn SEMS PDA distress alarm off: With cylinder valve closed and all residual air purged from respirator (see step 9 above) depress reset button twice (press, release and press again) and then twice again after the flashing green light sequence. The display will say "OFF," the unit will sound a quick two tone chirp and the SEMS PDA distress alarm will be inactive. The SEMS PDA distress alarm is now in the "OFF" condition.

#### **NOTE**

IF THERE IS STILL RESIDUAL PRESSURE IN THE SYSTEM, THE UNIT WILL REMAIN "ON" IN AUTOMATIC MODE.

#### **INSPECTION OF SEMS PDA PORTABLE UNIT**

When installed on a SCOTT SCBA, inspection and test of the SCOTT SEMS PDA Portable Unit is to be conducted along with inspection and test of the respirator and the SEMS PDA distress alarm before each use. To do this, the REGULAR OPERATIONAL INSPECTION procedures in your respirator instructions will require modification. The instructions below are to be added to the instructions for REGULAR

#### **WARNING**

IF THE LOW BATTERY INDICATION OCCURS AT ANY TIME DURING REGULAR OPERATIONAL INSPECTION, DO NOT USE THE RESPIRATOR. CHANGE ALL BATTERIES IMMEDIATELY AND REPEAT THE REGULAR OPERATIONAL TEST OR TAKE THE RESPIRATOR OUT OF SERVICE UNTIL THE BATTERIES ARE CHANGED AND THE REGULAR OPERATIONAL TEST IS SUCCESSFULLY PERFORMED. USE OF A RESPIRATOR WITH DEPLETED BATTERIES MAY LEAD TO A FAILURE OF THE RESPIRATOR WHICH COULD RESULT IN SERIOUS INJURY OR DEATH.

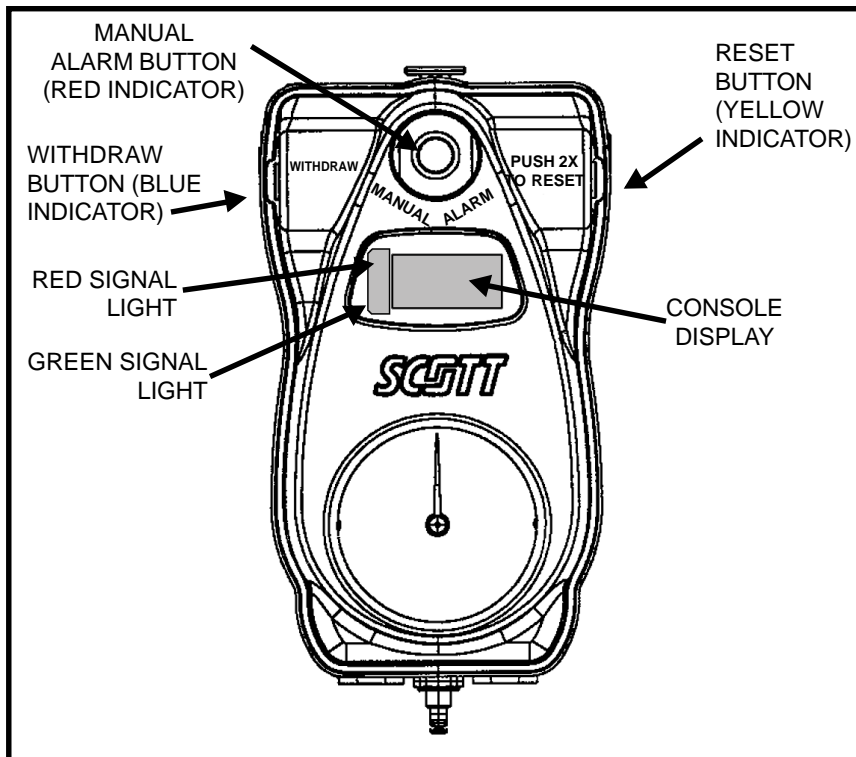

**FIGURE 5  
THE CONTROL CONSOLE**

OPERATIONAL INSPECTION of your respirator. If, during the inspection any malfunction of the respirator or the SEMS PDA Portable Unit is noted, remove the respirator from service and tag for repair by authorized personnel.

1. While performing the visual inspection of the respirator inspect all SEMS PDA Portable Unit enclosures, lenses, and wire conduits for cracks, wear or other damage. If damage is noted, remove respirator from service and tag respirator for repair by qualified personnel.
2. Check the operation of the SEMS PDA distress alarm in accordance with the REGULAR OPERATIONAL INSPECTION section of this instruction for the SEMS PDA distress alarm installed on your SCBA.
3. With an operating Base Station, verify that the SEMS PDA Portable Unit initializes and logs-in to the Base Station. When testing the SEMS PDA alarms, verify that the Portable Unit and Base Station are communicating with each other properly.
4. Verify that the batteries are properly installed and that there is no "BATT" indication on the display.
5. Send an "EVAC" signal to the SEMS PDA Portable Unit and check the response. Verify that both the ALL-CALL and the Selective Evacuation signals are properly received by the Portable Unit.
6. When testing the "LOW AIR" alarm operation, verify that the proper signal is transmitted to the Base Station.

On a regular basis established by your respiratory protection program, each SEMS Base Station must be inspected and tested for proper operation. Each of the functions defined in the USE OF THE SEMS BASE STATION section of this instruction must be checked and verified to be operating properly. If any malfunction is found, remove the Base Station from service and tag for repair by authorized personnel.

### **WARNING**

**FOLLOW REGULAR OPERATIONAL INSPECTION PROCEDURE EXACTLY. IF THE SEMS PORTABLE UNIT OR BASE STATION DOES NOT OPERATE AS DESCRIBED OR IF ANY OTHER OPERATIONAL MALFUNCTION IS NOTED, DO NOT USE THE RESPIRATOR. USE OF A MALFUNCTIONING RESPIRATOR MAY RESULT IN SERIOUS INJURY OR DEATH.**

## BATTERY REPLACEMENT

### SEMS PDA DISTRESS ALARM PORTABLE UNIT

Three batteries are required to operate the SEMS PDA Distress Alarm Portable unit: two in the Sensor Module assembly and one in the Control Console. **It is recommended to replace ALL batteries at the same time.** To change batteries, place the respirator in a clean, non-hazardous area. Close respirator cylinder valve, open regulator purge valve letting out all the trapped air, close regulator purge valve, press the reset button twice and twice again after the flashing green light sequence. Display will say "OFF", unit will sound a two tone chirp and green light will go out.

#### NOTE

ALWAYS BE SURE THAT CYLINDER VALVE IS OFF AND SEMS PDA DISTRESS ALARM IS COMPLETELY INACTIVE BEFORE CHANGING BATTERY. NEVER REMOVE OR REPLACE BATTERY WITH SYSTEM PRESSURIZED OR DAMAGE MAY OCCUR TO ELECTRONIC COMPONENTS.

#### BACKFRAME BATTERIES

1. When replacing batteries on respirators equipped with Backframe, P/N 804415-XX, remove the cylinder and position the respirator with the Sensor Module facing upward as shown in FIGURE 6.

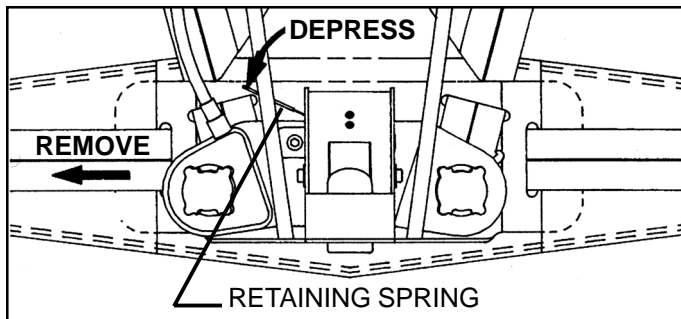

FIGURE 6

2. Depress the SEMS PDA distress alarm retaining spring and slide the Sensor Module from Backframe as shown in FIGURE 6.

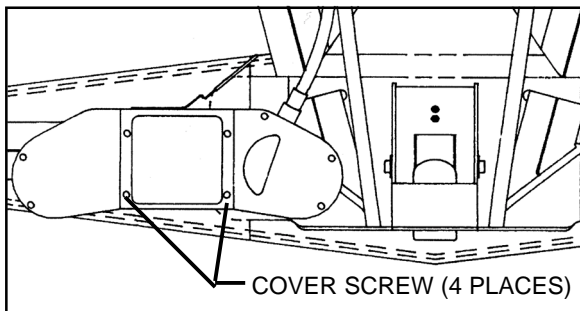

FIGURE 7  
BATTERY COVER

3. Turn Sensor Module over to expose the battery cover, shown in FIGURE 7 and replace batteries as instructed in paragraphs 5 through 9 of this section.

#### CAUTION

SYSTEM MUST NOT BE PRESSURIZED WHEN BATTERIES ARE INSTALLED. DAMAGE TO THE ELECTRONIC COMPONENTS MAY RESULT IF BATTERIES ARE INSTALLED WITH SYSTEM PRESSURIZED.

#### WARNING

THE SEMS PDA DISTRESS ALARM IS INTENDED TO ASSIST IN LOCATING A PERSON WHO MAY BE IN A LIFE THREATENING SITUATION. FAILURE TO FOLLOW THE INSTRUCTIONS FOR OPENING, CHANGING ALL BATTERIES AND RE-CLOSING BOTH BATTERY COMPARTMENTS MAY RESULT IN DAMAGE WHICH COULD CAUSE FAILURE OF THE PASS DURING A LIFE THREATENING EMERGENCY OR COULD CAUSE A FIRE OR EXPLOSION IN A FLAMMABLE OR EXPLOSIVE ATMOSPHERE POSSIBLY RESULTING IN SERIOUS INJURY OR DEATH.

- When replacing batteries on respirators equipped with Harness and Backframe, P/N 804173-XX, position respirator with the cylinder down exposing the battery cover on the back of the Sensor Module, as shown in FIGURE 8.

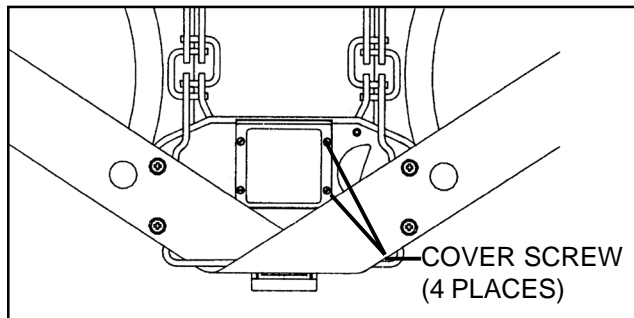

**FIGURE 8**  
**BATTERY COVER**

- To remove battery cover, first loosen all 4 cover screws 1 or 2 turns each, then fully loosen the screws so the cover can be removed. Carefully remove cover and set aside.
- Remove used batteries from battery compartment by lifting edge of batteries at contact end, using a finger or the flat blade of a screw driver, being careful not to damage battery contacts or sealing rib around battery compartment.
- Install two (2) fresh new batteries. **Always replace both batteries at the same time.** Use only pairs of the following: Eveready Alkaline No. 522 or EN22, Duracell Alkaline No. PC1604 or MN1604, or for increased service life use Ultralife Lithium Battery No. U9VL. Be sure batteries are installed with the terminals positioned as indicated by symbols molded in bottom of battery compartment.
- The battery cover must be installed so that it is water tight after replacement. Clean the sealing rib around battery compartment and sealing face of the cover, shown in FIGURE 9, by wiping with a clean damp cloth to remove any dirt or foreign matter which might prevent a proper seal. Check cover gasket for tears or cuts. If damage is found, remove respirator from service and tag for repair by authorized personnel.

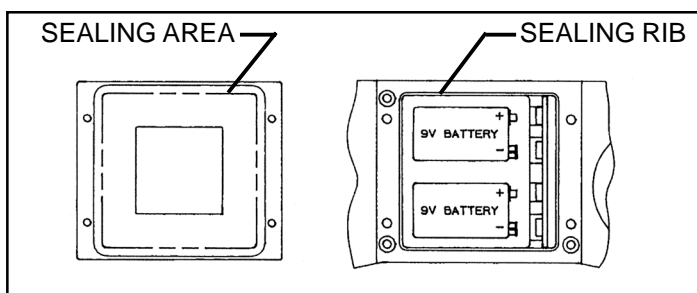

**FIGURE 9**  
**BATTERY COMPARTMENT AND COVER SEAL**

**CHECK YOUR WORK!**  
BEFORE ASSEMBLY OF BATTERY COVER, CHECK TO SEE BATTERY IS A FRESH, NEW BATTERY OF THE TYPE INDICATED AND THAT EMS HAS BEEN INSTALLED PROPERLY.

- Install battery cover and evenly tighten 4 cover screws by moving around the cover in a clockwise direction, turning each screw 1 or 2 turns at a time until cover is fully seated. On Backframe, P/N 804415-XX, reinstall the Sensor Module by sliding in backframe until retaining spring snaps into place as shown in FIGURE 6.

**BATTERY REPLACEMENT CONTINUED ON NEXT PAGE...**

## CONTROL CONSOLE BATTERY

1. To replace the battery in the Control Console, position the respirator so the Control Console battery cover is accessible as shown in FIGURE 10.



**FIGURE 10**

2. To remove battery cover, first loosen all 4 cover screws 1 or 2 turns each, then fully loosen the screws so the cover can be removed. Carefully remove cover and set aside.
3. Remove used battery from battery compartment by lifting bottom of battery, using a finger or the flat blade of a screw driver, being careful not to damage battery contacts or sealing rib around battery compartment.
4. Install one (1) fresh new battery. Use only one of the following: Eveready Alkaline No. 522 or EN22, Duracell Alkaline No. PC1604 or MN1604, or for increased service life use Ultralife Lithium Battery No. U9VL. Be sure battery is installed with the terminals positioned as indicated by symbols on label in bottom of battery compartment.
5. The battery cover must be installed so that it is water tight after replacement. Clean the sealing rib around battery compartment and sealing face of the cover, shown in FIGURE 11, by wiping with a clean damp cloth to remove any dirt or foreign matter which might prevent a proper seal. Check cover seal for tears or cuts. If damage is found, remove respirator from service and tag for repair by authorized personnel.

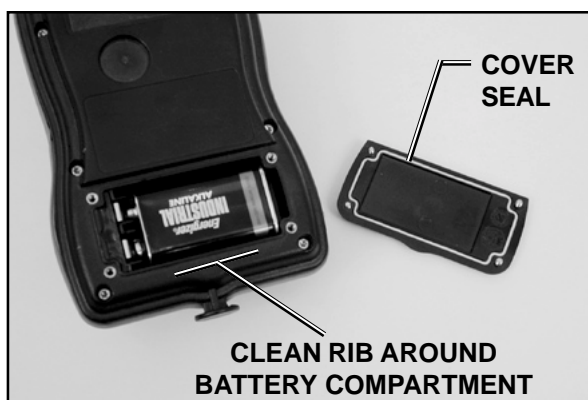

**FIGURE 11**

### BATTERY COMPARTMENT AND COVER SEAL

6. Install battery cover and evenly tighten 4 cover screws by moving around the cover in a clockwise direction, turning each screw 1 or 2 turns at a time until cover is fully seated. AFTER REPLACEMENT OF BATTERIES, PERFORM A REGULAR OPERATIONAL INSPECTION BEFORE RETURNING RESPIRATOR TO SERVICE.

### CHECK YOUR WORK!

BEFORE ASSEMBLY OF BATTERY COVER, CHECK TO SEE BATTERY IS A FRESH, NEW BATTERY OF THE TYPE INDICATED AND THAT EMS HAS BEEN INSTALLED PROPERLY.



## **SEMS PDR BASE STATION**

Battery replacement for the SEMS PDR Base Station is as follows:

1. Place the Base Station in a clean, non-hazardous area. Verify that the unit is not in use and is OFF.
2. Set the Base Station with the control panel face up and the bottom of the unit accessible.
3. Remove the three (3) battery caps from the battery compartments

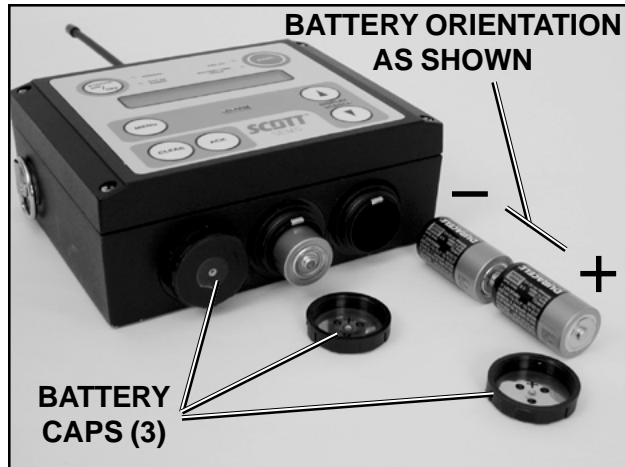

**FIGURE 12**  
**BATTERY COMPARTMENTS ON BASE STATION**

4. by unthreading them counterclockwise. See FIGURE 12.
5. Remove the six (6) depleted batteries.
6. Install six (6) fresh new "C" cell batteries, two in each battery compartment. Use six (6) of the following: Duracell MN1400, or Eveready Alkaline No. E93 or EN93. Insert batteries with the bottom "-" end first and with the top "+" end toward the battery cap. Be sure orientation of batteries is as noted.
7. Replace the three (3) battery caps by threading them on clockwise until snug.
8. Power up the Base Station and perform the REGULAR OPERATIONAL INSPECTION as defined in this instruction.

### **CHECK YOUR WORK!**

**BEFORE ASSEMBLY OF BATTERY COVER, CHECK TO SEE BATTERY IS A FRESH, NEW BATTERY OF THE TYPE INDICATED AND THAT EMS HAS BEEN INSTALLED PROPERLY.**

## **MAINTENANCE**

Except for programming and battery changing, there are no service operations or user serviceable parts available to the user.

## WARNING

**READ AND UNDERSTAND THE COMPLETE INSTRUCTION MANUAL BEFORE USING A RESPIRATOR WITH A SEMS PDA DISTRESS ALARM INSTALLED.**

### QUICK REFERENCE GUIDE TO USE OF THE SEMS PDA DISTRESS ALARM:

WHEN YOU WANT TO:	YOU DO:	THE SEMS PDA DISTRESS ALARM DOES:
Turn it on.	Open cylinder valve (cylinder <u>must</u> have air in it).	3 quick audible chirps, green flashing light on control console.
Reset pre-alarm	Move so that the respirator moves or press reset button once.	Red flashing light changes to green, ascending/descending tone stops (3 quick audible chirps if button was pressed).
Reset full alarm	Press reset button on control console twice (push, release, push again).	Loud 3 tone chirp stops, 3 quick chirps, then red flashing light changes to green flashing light.
Turn it off (finished with use)	Close cylinder valve, open regulator purge valve letting out all the trapped air, close regulator purge valve, press reset button twice after flashing green light sequence.	The flashing light goes out and display will say OFF. Unit will sound a two tone chirp at turn off.
Turn on the manual alarm.	Press alarm button on control console (works whether the SEMS PDA distress alarm is on or off).	Goes into full alarm, loud 3 tone chirps from sensor module and bright <u>red</u> flashing light from control console.

WHEN THE SEMS PDA DISTRESS ALARM IS:	IT INDICATES THAT:
Quiet. No lights or sound	The SEMS PDA distress alarm is off or the batteries are used up or removed.
Flashing the green light	The SEMS PDA distress alarm is on, in automatic mode, and monitoring your motion.
Flashing the red light and sounding an ascending/descending tone.	You have not moved in the last 20 seconds, SEMS PDA distress alarm will go into full alarm in 12 seconds or less if you do not move.
Flashing the red light and sounding a loud continuous 3 tone chirp	Full alarm: You have not moved in the last 30 seconds or more or you pushed the manual alarm button and held at least two seconds.
Chirping once every 2 seconds with no light flashing	The backframe batteries are low. You must replace all batteries before using the SEMS PDA distress alarm again (it will work in low battery condition long enough to let you finish the cylinder of air you are on).

## PERFORMANCE SPECIFICATIONS

### **Sound Levels:**

Pre-Alarm... ..... 70 to 105 dBA incrementally at left ear  
Full-Alarm ..... 95 to 100 dBA @ 9.9 Ft (3m)  
Frequency Range ..... 1.5 KHz to 4 KHz

### **Battery Life (fresh battery)**

Alkaline Battery:

Automatic (green flashing light, no sound) ..... Approx. 60 hours  
Full Alarm (red flashing light, 95 dBA sound).....Approx. 8 hours

Lithium Battery:

Automatic (green flashing light, no sound) ..... > 120 hours  
Full alarm (red flashing light, 95 dBA sound) ..... 8-16 hours

### **Compliance**

The Scott SEMS PDA distress alarm is a NIOSH approved accessory for use on only the following Scott AIR-PAK and AIR-PAK FIFTY respirators:

(NIOSH approval numbers have been included for identification):

Scott 2.2 Air-Pak (30 min.)	TC-13F-80
Scott 3.0 Air-Pak (30 min.)	TC-13F-366
Scott 4.5 Air-Pak (30 min.)	TC-13F-76
Scott 4.5 Air-Pak (45 min.)	TC-13F-212
Scott 4.5 Air-Pak (60 min.)	TC-13F-96

### **NOTE**

DO NOT USE A FIBERGLASS WRAPPED ONE HOUR CYLINDER ON A MODEL 4.5 AIR PAK EQUIPPED WITH A SEMS PDA DISTRESS ALARM AS THE WEIGHT WILL EXCEED THE 35 LBS APPROVAL LIMIT FOR SCBA's ESTABLISHED BY NIOSH.

Report any operational malfunctions to the certification agency Safety Equipment Institute (SEI), 1307 Dolley Madison Blvd. Suite 3A, McLean, VA 22101, (703) 442-5732, FAX (703) 442-5756.

**NOTICE:  
THESE USER INSTRUCTIONS  
ARE TO BE REMOVED ONLY  
BY THE END USER.**

**Scott**  
**Health & Safety**  
ISO 9001 REGISTERED

89502-01 Rev A 6/03

***tyco***

**SCOTT<sup>®</sup>**  
**HEALTH & SAFETY**

Health & Safety Products  
Monroe Corporate Center  
PO Box 569  
Monroe, NC 28111  
Telephone 1-800-247-7257  
FAX (704) 291-8330  
[www.scotthealthsafety.com](http://www.scotthealthsafety.com)

Printed in USA

## Free Manuals Download Website

<http://myh66.com>

<http://usermanuals.us>

<http://www.somanuals.com>

<http://www.4manuals.cc>

<http://www.manual-lib.com>

<http://www.404manual.com>

<http://www.luxmanual.com>

<http://aubethermostatmanual.com>

Golf course search by state

<http://golfingnear.com>

Email search by domain

<http://emailbydomain.com>

Auto manuals search

<http://auto.somanuals.com>

TV manuals search

<http://tv.somanuals.com>