

# RCA

## **TV/Radio/CD Player User's Manual**

Changing Entertainment. Again.



# Important Information

## CAUTION

RISK OF ELECTRIC SHOCK  
DO NOT OPEN

Caution: To reduce the risk of electric shock, do not remove cover (or back). No user serviceable parts inside. Refer servicing to qualified service personnel.



This symbol indicates "dangerous voltage" inside the product that presents a risk of electric shock or personal injury.



This symbol indicates important instructions accompanying the product.

## CAUTION

THIS PRODUCT UTILIZES A LASER. USE OF CONTROLS OR ADJUSTMENTS OR PERFORMANCE OF PROCEDURES OTHER THAN THOSE SPECIFIED HEREIN MAY RESULT IN HAZARDOUS RADIATION EXPOSURE. DO NOT OPEN COVERS AND DO NOT REPAIR YOURSELF. REFER SERVICING TO QUALIFIED PERSONNEL.

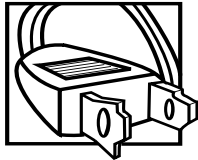

**Caution:** To prevent electric shock, match wide blade of plug to wide slot, fully insert.

**Attention:** Pour éviter les chocs électriques, introduire la lame la plus large de la fiche dans la borne correspondante de la prise et pousser jusqu'au fond.

Refer to the identification/rating label located on the back panel of your product for its proper operating voltage.

FCC Regulations state that unauthorized changes or modifications to this equipment may void the user's authority to operate it.

**Cable TV Installer:** This reminder is provided to call your attention to Article 820-40 of the National Electrical Code (Section 54 of the Canadian Electrical Code, Part 1) which provides guidelines for proper grounding and, in particular, specifies that the cable ground shall be connected to the grounding system of the building as close to the point of cable entry as practical.

## WARNING

To reduce the risk of fire or electric shock, do not expose this product to rain or moisture.

**CLASS 1  
LASER  
PRODUCT**

## Product Registration

Please fill out the product registration card (packed separately) and return it immediately. Returning this card allows us to contact you if needed.

## Product Information

Keep your sales receipt to obtain warranty parts and service and for proof of purchase. Attach it here and record the serial and model numbers in case you need them. The numbers are located on the product.

Model No. \_\_\_\_\_ Serial No. \_\_\_\_\_ Purchase Date: \_\_\_\_\_

Dealer/Address/Phone: \_\_\_\_\_

# Connections & Setup

## Chapter Overview:

- Under Cabinet Mounting Instructions
- TV Setup
- Front Panel Controls
- Back Panel Jacks
- Bottom Side Controls
- Install the Battery in the Remote
- The Remote Control

Changing Entertainment. Again.

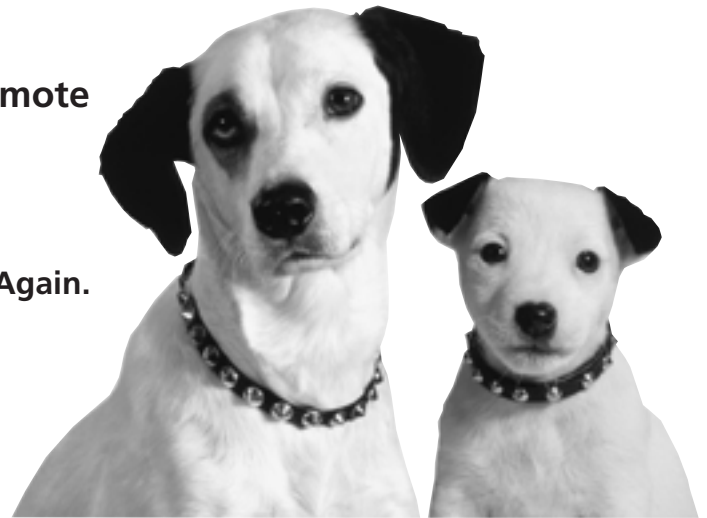

# Connections & Setup

---

## Under Cabinet Mounting Instructions

### Before Mounting

- Empty contents from the selected cabinet which the unit will be mounted.
- Clean the underside of the cabinet.
- We recommend the unit be mounted to the front edge of the cabinet.

### Tools Required

- Drill and Drill Bit
- Nail or Awl
- Phillips Screwdriver
- Masking Tape
- Ruler or Tape Measure
- Scissors
- Countersink (Optional)
- Safety Glasses

### Parts Packed With Your Unit

**Screws:** 4- 2 1/2" Phillips head screws  
4- 1 3/4" Phillips head screws  
4- 1" Phillips head screws



**Spacers:** 4- 3/4"  
4- 1/2"  
4- 1/4"

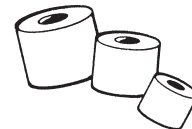

**Washers:** 4 

**Cord Hooks:** 2



### Mounting Procedure

1. Position template in desired location
2. Use tape to hold template in position.
3. Drill four 4.5 mm (3/16") holes at the locations shown.
4. Remove paper template.
5. Attach unit using four screws and spacers as required to adjust to desired height.

Once you have attached your unit to the cabinet you can use the supplied cord hooks to store excess cord.

## TV Setup

To set up your TV to tune to channels, you must first choose which type of signal it is receiving.

### Choosing Your Signal

1. Locate the TV/CATV button underneath your unit.
2. If you have a dipole antenna connected to your TV, press the button so that *TV* is displayed to the left of the channel number on the LCD panel display. If you are using cable or a cable box for your TV signals, press the button until the LCD panel display shows the correct signal type: *STD* for standard cable or *HRC* or *IRC* for certain cable systems.

### Complete Auto Channel Search

1. Locate the AUTO PROGRAM button underneath your unit.
2. Press the button to begin channel search. This tells the TV to search automatically for all the channels available through the antenna input. When the TV finds an active channel, it places it in the channel list; inactive channels (weak stations or channels with no signal at all) will be removed from the channel list.

### Adding or Removing Channels

You might want to add or remove channels if some of them are not active, have weak signals, or you do not want them in your channel memory. A channel that has been removed can still be selected by pressing the remote control's number buttons.

1. If your TV is not on, press the TV button.
2. Tune to the station you want to delete by using the CH up or down button. To tune to a station you want to add, enter the number using the number buttons on the remote control.
3. Press the ADD/DELETE button underneath your unit to add or delete the station.

# Connections & Setup

---

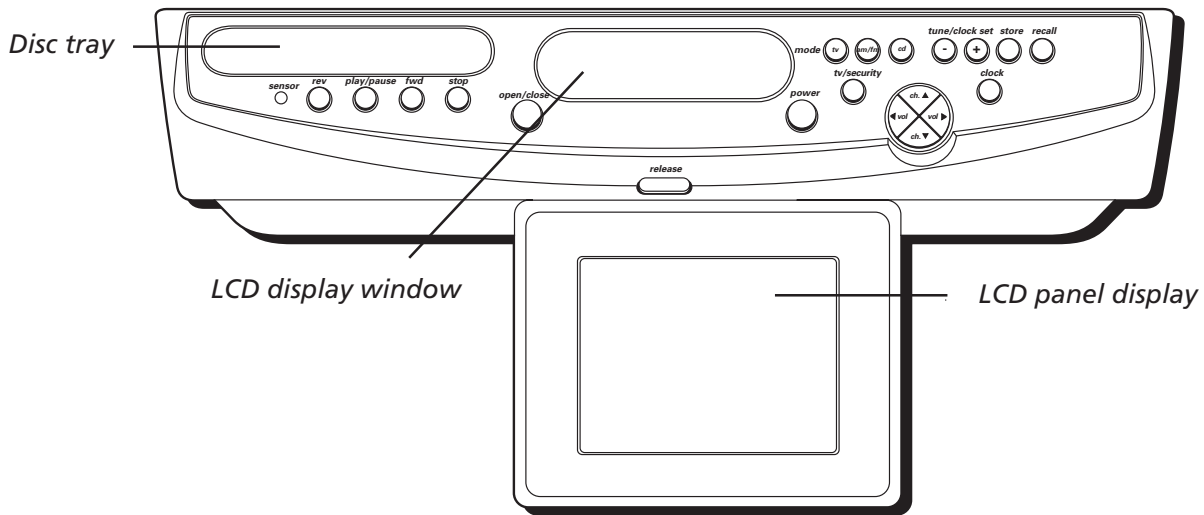

## Front Panel Controls

**Disc Tray** Insert CDs or MP3s in this tray.

**LCD Display Window** This window displays the time. When playing a disc, the window displays the track number.

**LCD Panel Display** Displays the video when TV receives a signal or Video input. Close the LCD panel to turn off the TV automatically.

**Important Note:** In order to conserve the LCD panel display life, make sure the TV is turned off when the screen is not in use by either pressing the POWER button or simply closing the LCD panel. The LCD panel display should not be used as a light as continual operation significantly reduces the life of the unit.

### Controls (listed alphabetically)

**AM/FM MODE** Press this button to choose the FM radio signal; press this button again to choose AM radio signal.

## Connections & Setup

---

**CD MODE** Press this button to put the unit in the CD player mode in order to play either an Audio CD or MP3 disc.

**CH (up and down) buttons** When in TV mode, scans up or down through the current channel list. Press once to change the channel up or down; press and hold to continue changing channels.

**CLOCK** Press this button to tune to the clock in order to change the time.

**FWD** Press this button to scan forward to the next track on a CD or MP3.

**OPEN/CLOSE** Opens or closes the disc tray.

**PLAY/PAUSE** Press the PLAY/PAUSE button once to start disc play; press again to pause the disc. The disc will remain paused until you press the button again to resume play.

**POWER** Press this button to power on or off the unit.

**RECALL** Press this button to cycle through the preset radio stations.

**RELEASE** Push this button to release the LCD panel. You can then adjust the screen by moving it up/down and rotating it left/right.

**REV** Press this button to scan backward to the previous track on a CD or MP3.

**SENSOR** Receives a signal from the remote control.

**STOP** Press this button to stop disc play.

**STORE** Press this button to display the preset numbers for storing radio stations into memory. You can store multiple channels into the memory.

**TUNE/CLOCK SET (up and down) buttons** When in radio mode, press this button to scan up or down through the radio channels. When in clock mode, press the up or down button and the CLOCK button simultaneously to set the clock running from minute to hour.

**TV MODE** Press this button to display the TV signal.

**TV/SECURITY** Press this button to select TV station input or security/video source input.

**VOL (up and down) buttons** Increase or decrease the output sound coming from the built-in speakers.

## Connections & Setup

---

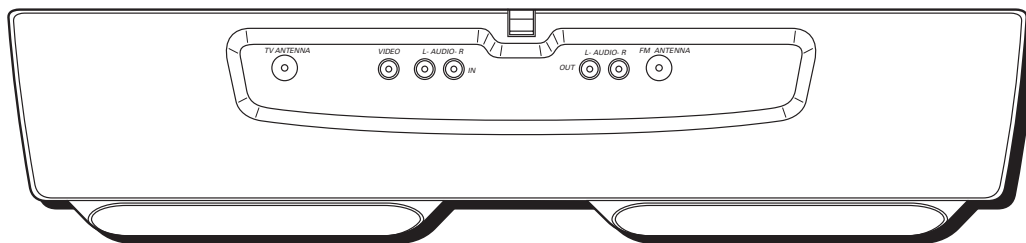

### Back Panel Jacks (listed from left to right)

**TV ANTENNA** Connect the coaxial cable from your cable or antenna to this jack.

**VIDEO IN** Connect a video cable to this jack to receive the video signal source input, including most security cameras.

**L/R AUDIO IN** Receives audio input signals from another component such as VCR, camcorder or Internet access device.

**L/R AUDIO OUT** Sends audio signals from the unit to another component such as a receiver or amplifier, or outputs the sound to powered (amplified) speakers.

**FM ANTENNA** Connect an FM radio antenna to improve radio reception.



## Connections & Setup

---

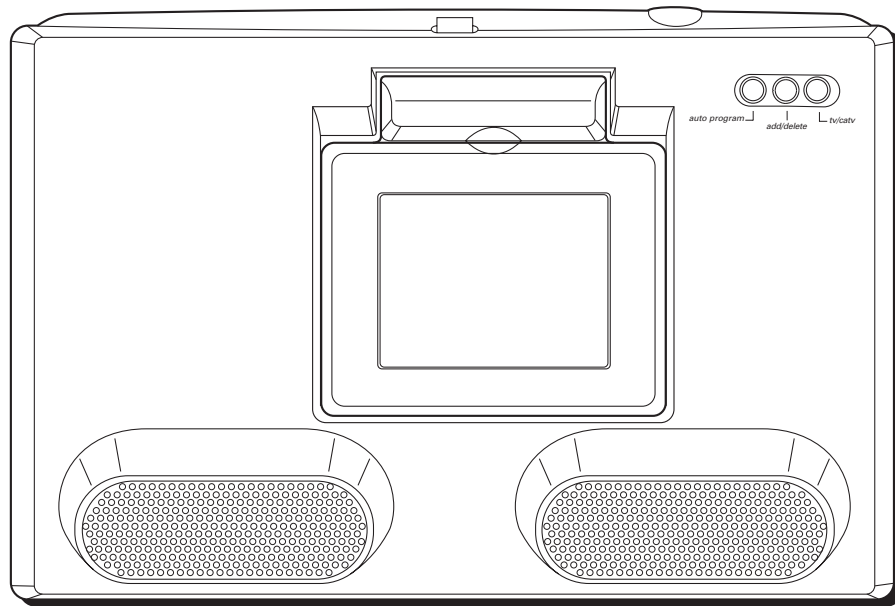

### Bottom Side Controls (listed from left to right)

**AUTO PROGRAM** Press this button to begin auto channel search.

**ADD/DELETE** Press this button to either add or delete a station from your TV after you have completed the auto channel search.

**TV/CATV** Press this button once if you have an antenna connected to your unit; press again if you have cable or a cable box connected to your unit.

## Connections & Setup

---

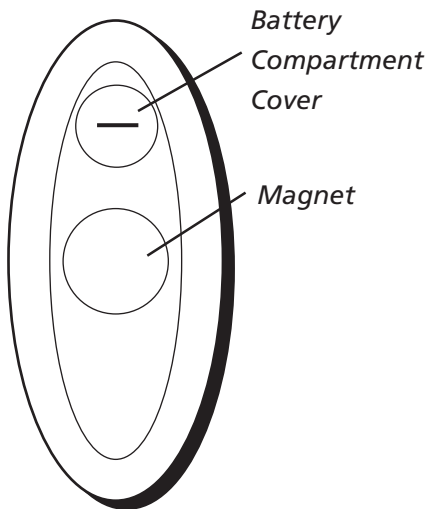

### Install the Battery in the Remote

1. Use a coin to remove the battery compartment cover on the back of the remote.
2. Insert new lithium battery.
3. Put the battery compartment cover back on the remote.

**Note:** When the remote is not in use it can be stored on the side of the unit opposite the CD player.

### Important Battery Information

- If you're not going to use the remote for a month or more, be sure to remove the battery because it can leak and cause damage.
- Dispose of battery in the proper manner, according to federal, state, and local regulations.
- Any battery may leak electrolyte if mixed with a different battery type, if inserted incorrectly, if disposed of in fire, or if an attempt is made to charge a battery not intended to be recharged.
- Discard leaky battery immediately. A leaking battery can cause skin burns or other personal injury.



## The Remote Control

### (Buttons Listed in Alphabetical Order)

**0-9 and 100 (Number buttons)** Enter channel numbers directly through the remote control. To enter a number above 99, for example 113, press 100, then 1 and then 3.

**AM/FM** Press this button to select an FM radio signal; press again to select an AM radio signal.

**CD** Puts the remote in CD mode, allowing you to play a CD or MP3 disc.

**Mute** Lowers the volume to its minimum level. Press again to restore volume.

**PIX (Picture)** Displays the picture screen, allowing you to adjust Contrast, Brightness, Color and Tint Level.

**POWER** Turns on and off the unit.

**Tune (up and down) buttons** Scans through the channel list when in TV mode. Tunes frequency in radio mode. When in CD mode, skips forward/backward in disc tracks. Press once to change the channel, station or track one at a time; press and hold to continue changing.

**TV** Press this button to receive the signal from the TV.

**Vol (up and down) buttons** Decreases or increases the volume to the unit.

**(This page intentionally left blank)**

# Using the CD Player and Radio

## Chapter Overview

- Types of Discs Your Unit Will Play
- Loading and Playing Discs
- Using the Radio
- Troubleshooting
- Limited Warranty
- Accessory Order Form

Changing Entertainment. Again.



# Using the CD Player and Radio

---



## Types of Discs Your Unit Will Play

- Audio discs – Audio CDs contain musical or sound content only.
- MP3 discs – A disc that contains audio files (for example, a CD-R with downloaded MP3 files).



## Loading and Playing Discs



Insert with the label facing up.

Before you load a disc, make sure that it is compatible with the player. Note that the following discs CANNOT be used with this player:

- Laserdisc
- CD-I, CD-ROM, CD-RW, DVD-ROM
- MiniDisc
- CD-G discs play audio only, not graphics

## To Load and Play an Audio CD and MP3

**Note:** An MP3 disc will play tracks in the order they were recorded.

1. Press the OPEN/CLOSE button to the right of the disc tray.
2. Place a disc gently into the tray with the disc's label facing up.
3. Gently press in on the tray door to close the tray.
4. Press PLAY/PAUSE to begin playback.
5. Press STOP to stop playback.

# Using the CD Player and Radio

---

## Skipping Tracks

The LCD display window shows the current track and the elapsed playing time of that track. Use the FWD button to go to the next track and the REV button to go to the previous track. Press and hold these for a quick search through a track.

## Using the Radio

1. Press the AM/FM mode button to put the unit in radio mode and to receive the FM radio signal. Press the button again to receive the AM radio signal.
2. Check the LCD display window to see which radio signal you selected.

## Station Search

The radio tunes to the last station it received. Press the TUNE up or down button to tune to the next available station. Press and hold to scan quickly through the stations.

## Setting a Station

If you want to set a radio station into the memory:

1. Select the station you want to set by using the TUNE up or down button.
2. Press the STORE button (*MEMO* flashes in the LCD display window).
3. Press RECALL to cycle through the preset stations.
4. Press STORE once you have chosen the location where you want to save the station. This station will be saved until you reset the station.
5. Repeat steps 1 - 4 to store additional radio stations.
6. To access the stored stations, repeatedly press RECALL to cycle through the preset stations.

# Using the CD Player and Radio

---

## ***Troubleshooting***

---

### **Poor TV reception**

- Check antenna connections. Make sure all of the cables are firmly connected to the jacks.
- Maybe the cable/air setting is set to the wrong position. See page 3 for more information.

### **Black and white reception**

- Maybe the cable/air setting is set to the wrong position. See page 3 for more information.

### **Poor radio reception**

- Attach an FM antenna for better reception.

### **Disc won't play**

- Insert a disc with the label side facing up.
- Check the type of disc you put into the player. This player only plays audio CDs and MP3s.

### **Play starts, but then stops immediately**

- The disc is dirty. Clean it.
- Condensation has formed. Allow player to dry out.

### **Remote control will not function**

- Something might be between the remote and the remote sensor on the component. Make sure there is a clear path.
- Maybe the battery in remote is weak, dead or installed incorrectly. Put a new battery in the remote.
- The remote might be in the wrong mode. To operate your CD Player, press CD on the remote before you press any other buttons. If you're operating the TV, press the TV button first, etc.



## Limited Warranty

### **What your warranty covers:**

- Defects in materials or workmanship.

### **For how long after your purchase:**

- 1 year from date of purchase- Unit exchange, which includes parts and labor.
- The warranty for rental units begins with the first rental or 45 days from date of shipment to the rental firm, whichever comes first.

### **What we will do:**

Exchange the unit with a new or, at our option, refurbished unit.

### **How you get service:**

- Call 1-800-951-9582 and have your unit's date of purchase and model/serial number ready. The model/serial number information is on the back of your unit.
- A representative will troubleshoot your problem over the phone.
- If the representative determines that you should receive a replacement unit you will be provided with a Service Request (SR) number and the location of a nearby exchange point if one exists. No returns will be accepted without the SR number.

### **To receive a replacement unit before you return yours:**

#### **Option I:**

1. Provide your Discover, MasterCard or Visa account number and expiration date to your phone representative. This is for security purposes only and your account will not be charged at this time.
2. We will send you a replacement unit.
3. If you return the unit to us within 14 days from the date you were provided a SR number, only items not covered by warranty will be charged to your account. If your unit is not received within 14 days, the suggested retail value of the receiver will be charged to your credit card. This amount will be credited, less a \$10 handling fee, if the unit is subsequently received.
4. Ship your defective unit back to us using the replacement unit's carton. Shipping instructions will be included on the carton along with your SR number which will allow you to easily ship the unit back to us. Make sure you insure your shipment in case of damage or loss. Include with the shipment:

# Limited Warranty

---

- Proof of purchase in the form of a bill of sale or receipted invoice which is evidence that the product is within the warranty period must be presented to obtain warranty service. For rental firms, proof of first rental is also required.
- A brief note describing your receiver problem.
- Your name, address and phone number.

## **Option II:**

1. For a fee of \$10.00, we will send a replacement unit to our exchange point.
2. The exchange location will notify you of its arrival.
3. Take your unit and evidence of purchase date, such as a bill of sale, to the exchange location and you will be provided the new or refurbished unit. Please retain all accessories such as the remote control hand unit.
4. If the repairs are covered by your warranty, you will not be billed.

**Thomson assumes no responsibility of warranty shipments from the customer to the factory if not shipped in the manner prescribed by Thomson.**

**Return transportation, storage, handling and insurance costs are your responsibility. We accept no responsibility in case of damage or loss.**

## **To receive a replacement unit after we have received your unit:**

- Write the SR number on the outside of the carton used to return the unit. Make sure you insure your shipment in case of damage or loss.
- Carefully pack the unit using the original box and packing material if possible. Please retain all accessories that were included with your unit such as the remote control hand unit.
- Include with the shipment:
  1. Proof of purchase in the form of a bill of sale or receipted invoice which is evidence that the product is within the warranty period must be presented to obtain warranty service. For rental firms, proof of first rental is also required.
  2. A brief note describing your unit's problem.
  3. Your name, address and phone number.
- The representative will advise the address to mail a cashier's check or money order for payment if there are any out of warranty labor or parts charges, and you elect not to use your credit card.
- After we receive your product, a new or refurbished unit will be shipped to you.

# Limited Warranty

---

## **What your warranty *does not* cover:**

- Acts of nature, such as but not limited to lightning damage.
- Adjustment of customer controls.
- Damage from misuse or neglect.
- A unit that has been modified or incorporated into other products or is used for institutional or other commercial purposes.
- Batteries.
- Units purchased or serviced outside the U.S.A.
- Shipping damage if the unit was not packed and shipped in the manner prescribed by Thomson.
- Storage fees may be charged by the exchange point if you fail to pickup the replacement unit in a timely manner.
- Customer Instruction. (Your Owner's Manual describes how to install, adjust, and operate your unit. Any additional information should be obtained from your dealer.)

## **Product Registration:**

- Please complete and mail the Product Registration Card packed with your product. It will make it easier to contact you should it ever be necessary. The return of the card is not required for warranty coverage.

## **Limitation of Warranty:**

- **THE WARRANTY STATED ABOVE IS THE ONLY WARRANTY APPLICABLE TO THIS PRODUCT. ALL OTHER WARRANTIES, EXPRESS OR IMPLIED (INCLUDING ALL IMPLIED WARRANTIES OF MERCHANTABILITY OR FITNESS FOR A PARTICULAR PURPOSE) ARE HEREBY DISCLAIMED. NO VERBAL OR WRITTEN INFORMATION GIVEN BY THOMSON MULTIMEDIA INC., ITS AGENTS OR EMPLOYEES SHALL CREATE A WARRANTY OR IN ANY WAY INCREASE THE SCOPE OF THIS WARRANTY.**
- **REPAIR OR REPLACEMENT AS PROVIDED UNDER THIS WARRANTY IS THE EXCLUSIVE REMEDY OF THE CONSUMER. THOMSON MULTIMEDIA INC. SHALL NOT BE LIABLE FOR INCIDENTAL OR CONSEQUENTIAL DAMAGES RESULTING FROM THE USE OF THIS PRODUCT OR ARISING OUT OF ANY BREACH OF ANY EXPRESS OR IMPLIED WARRANTY ON THIS PRODUCT. THIS DISCLAIMER OF WARRANTIES AND LIMITED WARRANTY ARE GOVERNED BY THE LAWS OF THE STATE OF INDIANA. EXCEPT TO THE EXTENT PROHIBITED BY APPLICABLE LAW, ANY IMPLIED WARRANTY OF MERCHANTABILITY OR FITNESS FOR A PARTICULAR PURPOSE ON THIS PRODUCT IS LIMITED TO THE APPLICABLE WARRANTY PERIOD SET FORTH ABOVE.**

# Limited Warranty

---

**How state law relates to warranty:**

- Some states do not allow the exclusion nor limitation of incidental or consequential damages, or limitations on how long an implied warranty lasts, so the above limitations or exclusions may not apply to you.
- This warranty gives you specific legal rights, and you also may have other rights that vary from state to state.

**If you purchased your product outside the United States:**

- This warranty does not apply. See your dealer for warranty information.

**Service calls which do not involve defective materials or workmanship are not covered by this warranty.**

**Costs of such service calls are the sole responsibility of the purchaser.**

# Other Information



**Mounting Kit**

The pieces in this kit allow you to mount your unit to your cabinet.



**Remote Control**

This is the remote control that came packed with your unit. Replacements or spares can be ordered as needed.

Detach Here



**Accessory Order Form**

Description	Part No.	Price	Qty
Mounting Kit	253185	\$14.95	
Remote Control BLC524	253186	\$34.95	
Remote Control BLC528	253187	\$34.95	

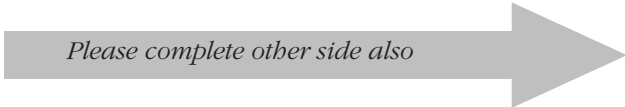

Prices are subject to change without notice.

Total Merchandise ..... \$ \_\_\_\_\_

Sales Tax ..... \$ \_\_\_\_\_

We are required by law to collect the appropriate sales tax for each individual state, country, and locality to which the merchandise is being sent.

Shipping and Handling ..... \_\_\_\_\_

Total Amount Enclosed ..... \$ 5.00

Use VISA, MasterCard, or Discover Card preferably. \$ \_\_\_\_\_

Money order or check must be in U.S. currency only.

No COD or CASH.

All accessories are subject to availability. Where applicable, we will ship a superseding model.

**Continued on next page.....**

# Other Information

## To Order

To place your order by phone, have your Visa, MasterCard or Discover Card ready and call the toll-free number listed below.

Use this number only to place an order for accessory items listed on this order form. **1-800-338-0376**

To place your order by mail, detach and mail the completed order form with credit card information, money order or check in US currency (made payable to Thomson multimedia Inc.) to the following address:

**Video Accessories**  
**PO Box 8419**  
**Ronks, PA 17573**

Detach Here



Charge your order on your VISA, MasterCard, or Discover Card by filling in below

### USE YOUR CREDIT CARD

**IMPORTANT:** Copy complete account number from your VISA card

Expiration date:

**IMPORTANT:** Copy complete account number from your MasterCard

Copy Number above your name on MasterCard  Expiration date:

**IMPORTANT:** Copy complete account number from your Discover Card

Expiration date:

\_\_\_\_\_  
**AUTHORIZED SIGNATURE**

Print or type your name and address clearly.

A complete and correct order will save you days of waiting.

Name: \_\_\_\_\_

Street: \_\_\_\_\_

\_\_\_\_\_ Apt: \_\_\_\_\_

City: \_\_\_\_\_

State: \_\_\_\_\_

Zip: \_\_\_\_\_

**Please make sure that both sides of this form have been filled out completely.**

- Allow 4 weeks for delivery.
- All accessories are subject to availability.
- Prices are subject to change.

**(This page intentionally left blank)**

**Visit the RCA web site at [www.rca.com](http://www.rca.com)**

---

Please do not send any products to the Indianapolis address listed in this manual or on the carton. This will only add delays in service for your product.

**Thomson multimedia Inc.**  
**10330 North Meridian Street**  
**Indianapolis, IN 46290**

©2002 Thomson multimedia Inc.  
Trademark(s)® Registered  
Marca(s) Registrada(s)  
Printed in Malaysia  
**TOCOM 1576838A**





## Free Manuals Download Website

<http://myh66.com>

<http://usermanuals.us>

<http://www.somanuals.com>

<http://www.4manuals.cc>

<http://www.manual-lib.com>

<http://www.404manual.com>

<http://www.luxmanual.com>

<http://aubethermostatmanual.com>

Golf course search by state

<http://golfingnear.com>

Email search by domain

<http://emailbydomain.com>

Auto manuals search

<http://auto.somanuals.com>

TV manuals search

<http://tv.somanuals.com>