

RCA

Two-Line Speakerphone with Call Waiting Caller ID User's Guide

Please read this manual before
operating this product for the
first time.



TOCOM 16211370

Model 25202

Important Information

Equipment Approval Information

Your telephone equipment is approved for connection to the Public Switched Telephone Network and is in compliance with parts 15 and 68, FCC Rules and Regulations and the Technical Requirements for Telephone Terminal Equipment published by ACTA.

1 Notification to the Local Telephone Company

On the bottom of this equipment is a label indicating, among other information, the US number and Ringer Equivalence Number (REN) for the equipment. You must, upon request, provide this information to your telephone company.

The REN is useful in determining the number of devices you may connect to your telephone line and still have all of these devices ring when your telephone number is called. In most (but not all) areas, the sum of the RENs of all devices connected to one line should not exceed 5. To be certain of the number of devices you may connect to your line as determined by the REN, you should contact your local telephone company.

A plug and jack used to connect this equipment to the premises wiring and telephone network must comply with the applicable FCC Part 68 rules and requirements adopted by the ACTA. A compliant telephone cord and modular plug is provided with this product. It is designed to be connected to a compatible modular jack that is also compliant. See installation instructions for details.

Notes

- This equipment may not be used on coin service provided by the telephone company.
- Party lines are subject to state tariffs, and therefore, you may not be able to use your own telephone equipment if you are on a party line. Check with your local telephone company.
- Notice must be given to the telephone company upon permanent disconnection of your telephone from your line.
- If your home has specially wired alarm equipment connected to the telephone line, ensure the installation of this product does not disable your alarm equipment. If you have questions about what will disable alarm equipment, consult your telephone company or a qualified installer.

2 Rights of the Telephone Company

Should your equipment cause trouble on your line which may harm the telephone network, the telephone company shall, where practicable, notify you that temporary discontinuance of service may be required. Where prior notice is not practicable and the circumstances warrant such action, the telephone company may temporarily discontinue service immediately. In case of such temporary discontinuance, the telephone company must: (1) promptly notify you of such temporary discontinuance; (2) afford you the opportunity to correct the situation; and (3) inform you of your right to bring a complaint to the Commission pursuant to procedures set forth in Subpart E of Part 68, FCC Rules and Regulations.

The telephone company may make changes in its communications facilities, equipment, operations or procedures where such action is required in the operation of its business and not inconsistent with FCC Rules and Regulations. If these changes are expected to affect the use or performance of your telephone equipment, the telephone company must give you adequate notice, in writing, to allow you to maintain uninterrupted service.

Interference Information

This device complies with Part 15 of the FCC Rules. Operation is subject to the following two conditions: (1) This device may not cause harmful interference; and (2) This device must accept any interference received, including interference that may cause undesired operation.

This equipment has been tested and found to comply with the limits for a Class B digital device, pursuant to Part 15 of the FCC Rules. These limits are designed to provide reasonable protection against harmful interference in a residential installation.

This equipment generates, uses, and can radiate radio frequency energy and, if not installed and used in accordance with the instructions, may cause harmful interference to radio communications. However, there is no guarantee that interference will not occur in a particular installation.

If this equipment does cause harmful interference to radio or television reception, which can be determined by turning the equipment off and on, the user is encouraged to try to correct the interference by one or more of the following measures:

- Reorient or relocate the receiving antenna (that is, the antenna for radio or television that is "receiving" the interference).
- Reorient or relocate and increase the separation between the telecommunications equipment and receiving antenna.
- Connect the telecommunications equipment into an outlet on a circuit different from that to which the receiving antenna is connected.

If these measures do not eliminate the interference, please consult your dealer or an experienced radio/television technician for additional suggestions. Also, the Federal Communications Commission has prepared a helpful booklet, "How To Identify and Resolve Radio/TV Interference Problems." This booklet is available from the U.S. Government Printing Office, Washington, D.C. 20402. Please specify stock number 004-000-00345-4 when ordering copies.

US NUMBER IS LOCATED ON THE CABINET BOTTOM
REN NUMBER IS LOCATED ON THE CABINET BOTTOM

IMPORTANT INFORMATION	2	MAKING CALLS WITH THE HANDSET	16
EQUIPMENT APPROVAL INFORMATION	2	MAKING CALLS WITH THE SPEAKERPHONE	16
INTERFERENCE INFORMATION	2	MAKING CALLS WITH THE OPTIONAL HEADSET ...	16
INTRODUCTION	5	RECEIVING CALLS WITH THE HANDSET	17
CONNECTIONS AND SETUP	6	RECEIVING CALLS WITH THE SPEAKERPHONE	17
BASE LAYOUT	6	RECEIVING CALLS WITH THE OPTIONAL	
PARTS CHECKLIST	7	HEADSET	17
TELEPHONE JACK REQUIREMENTS	7	SWITCHING BETWEEN THE SPEAKERPHONE,	
INSTALLATION	7	HANDSET, AND HEADSET	17
IMPORTANT INSTALLATION INFORMATION	7	PRE-DIALING TELEPHONE NUMBERS	18
INSTALLING THE PHONE	8	CALL TIMER	18
DATA PORT	10	MUTE	18
PROGRAMMING THE TELEPHONE	11	HOLD	19
DISPLAY LANGUAGE	11	PLACING A CALL ON HOLD	19
MANUALLY SETTING THE DATE AND TIME	11	RELEASING A CALL FROM HOLD	19
FLASH TIME	12	FLASH	19
HOUR FORMAT	12	REDIAL	19
CALL ALERT TONE	13	VOLUME	19
LOCAL AREA CODE	13	RINGER VOLUME	20
REGIONAL AREA CODES	14	SPEAKERPHONE, HANDSET, AND	
DISPLAY CONTRAST	14	HEADSET VOLUME	20
VOICE MAIL ACCESS CODES	15	CONFERENCE	20
RESTORING THE DEFAULTS	15	DO NOT DISTURB	20
TELEPHONE OPERATION	16	VOICE MESSAGING	21
TELEPHONE OPERATION	16		

WARNING: TO PREVENT FIRE OR ELECTRICAL SHOCK HAZARD, DO NOT EXPOSE THIS PRODUCT TO RAIN OR MOISTURE.



	<p>CAUTION: RISK OF ELECTRIC SHOCK DO NOT OPEN</p>	
<p>THE LIGHTNING FLASH AND ARROW HEAD WITHIN THE TRIANGLE IS A WARNING SIGN ALERTING YOU OF "DANGEROUS VOLTAGE" INSIDE THE PRODUCT.</p>	<p>CAUTION: TO REDUCE THE RISK OF ELECTRIC SHOCK, DO NOT REMOVE COVER (OR BACK). NO USER SERVICEABLE PARTS INSIDE. REFER SERVICING TO QUALIFIED SERVICE PERSONNEL.</p>	<p>THE EXCLAMATION POINT WITHIN THE TRIANGLE IS A WARNING SIGN ALERTING YOU OF IMPORTANT INSTRUCTIONS ACCOMPANYING THE PRODUCT.</p>
<p>SEE MARKING ON BOTTOM / BACK OF PRODUCT</p>		

Table of Contents

CALLER ID	22	STORING A NAME AND NUMBER IN MEMORY ...	25
CALLER ID (CID)	22	REVIEWING STORED NAMES & NUMBERS	25
SUMMARY SCREEN	22	CHANGING A STORED NAME OR NUMBER	26
RECEIVING AND STORING CID RECORDS	22	STORING THE LAST NUMBER DIALED	26
REVIEWING CID RECORDS	23	STORING A PAUSE	26
SAVING CID RECORDS TO MEMORY/PHONE		STORING A FLASH	26
DIRECTORY MEMORY	23	DIALING A STORED NUMBER	27
DELETING A CID RECORD	23	CHAIN DIALING	27
DELETING ALL CID RECORDS	23	DELETING ALL DIRECTORY MEMORY	28
DIALING BACK	23	OTHER INFORMATION	29
IF YOU PROGRAMMED YOUR LOCAL AREA		DISPLAY MESSAGES	29
CODE IN THE SETUP MENU	23	TROUBLESHOOTING GUIDE	29
IF YOU DID NOT PROGRAM YOUR LOCAL		GENERAL PRODUCT CARE	31
AREA CODE IN THE SETUP MENU	24	SERVICE	32
CALL WAITING CALLER ID	24	LIMITED WARRANTY	33
MEMORY	25	ACCESSORY ORDER FORM	37
DIRECT ACCESS MEMORY & DIRECTORY			
MEMORY	25		



CAUTION: When using telephone equipment, there are basic safety instructions that should always be followed. Refer to the IMPORTANT SAFETY INSTRUCTIONS provided with this product and save them for future reference.

Your Caller ID phone stores and displays specific information, provided by your local telephone company, to subscribers of Caller ID or similar caller identification services.

Your Caller ID phone enables you to:

- Identify callers before you answer the phone.
- View the time and date of each incoming call.
- Record up to 99 Caller ID messages sequentially.
- Know who called while you were away.

To get the most from your new phone, we suggest that you take a few minutes right now to read through this user's guide.

IMPORTANT: In order to use this unit, you must subscribe to either the standard Name/Number Caller ID Service or Caller ID with Call Waiting Service. To know who is calling while you are on the phone, you must subscribe to Caller ID with Call Waiting Service.

Connections and Setup

Base Layout

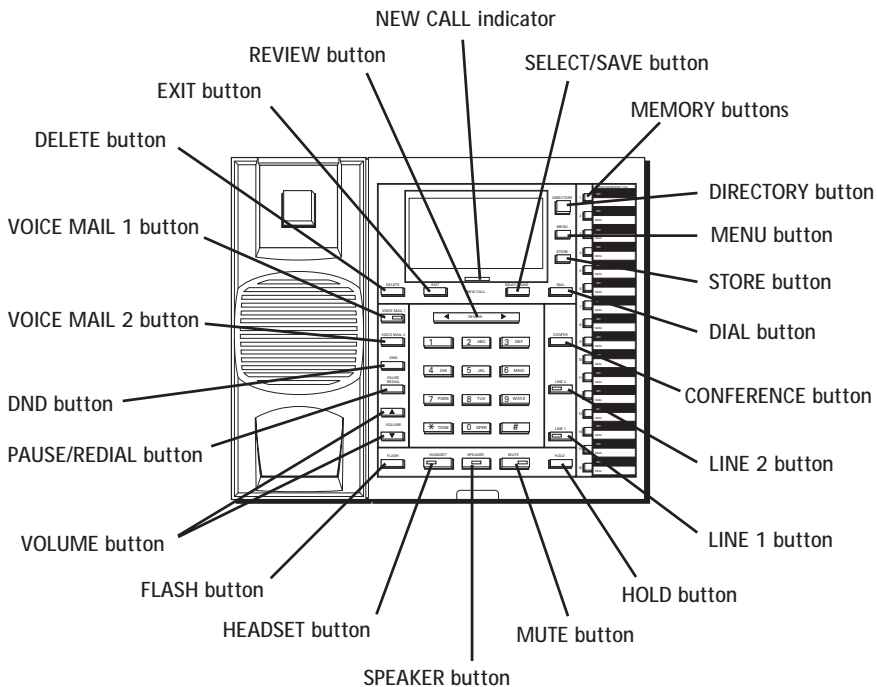

Parts Checklist

Make sure your package includes the following items:

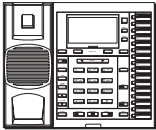

Base



Handset



Handset cord

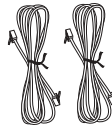

Line cords



AC power converter

Wall plate

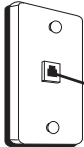

Modular telephone
line jack

Telephone Jack Requirements

To use this phone, you will need one RJ14C or two RJ11C type modular phone jacks, which might look like the one pictured here, installed in your home/office.

Installation

Important Installation Information

- Never install telephone wiring during a lightning storm.
- Never touch uninsulated telephone wires or terminals, unless the telephone line has been disconnected at the network interface.
- Use caution when installing or modifying telephone lines.
- Never install telephone jacks in wet locations unless the jack is specifically designed for wet locations.

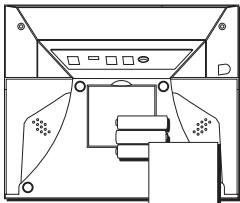

Installing the Phone

1. Choose an area near an electrical outlet and telephone wall jack. Your phone should be placed on a level surface, such as a table top or desk.
2. Install 3 AA-size alkaline batteries (not included) for back up power in the event of a power failure.
 - Use a screwdriver to loosen and lift up the battery compartment door located on the bottom of the phone.
 - Insert the batteries as shown on the diagram inside the battery compartment.
 - Snap the battery compartment door back into place and tighten the screw.

NOTE: If the low battery icon appears in the display, you need to replace the batteries. It is important that you replace them as soon as possible to maintain unit operation when electrical power is off. As a precaution, you may want to write down any stored information you do not want erased.

IMPORTANT: If you are not going to use the telephone for more than 30 days, remove the batteries because they can leak and damage the unit.

3. Connect the AC power converter to an electrical outlet and the DC connector to the back of the base.



CAUTION: Use only the ATLINKS USA 5-2495 power converter that is compatible with this unit. Using other power supplies may damage the unit.

4. Connect the telephone line cords:

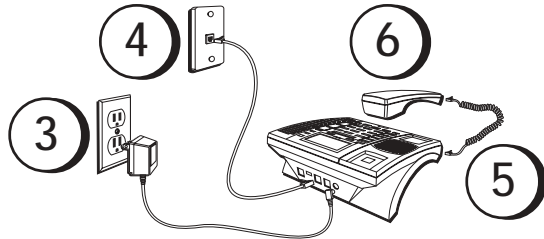

If you have two telephone lines installed on a single jack, plug one end of the straight telephone line cord into the jack marked LINE 1+2 on the back of the base. Plug the other end into the 2-line wall jack.

If you have two separate telephone line jacks, plug one telephone line cord into the jack marked LINE 1+2 and another cord into the jack marked LINE 2. Plug the other end of each line cord into separate wall jacks.

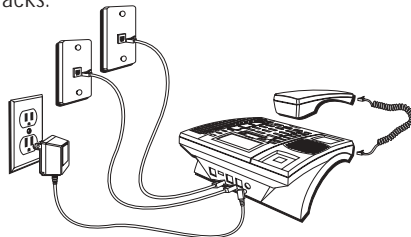

NOTE: To use two line, you must have two telephone lines with unique telephone numbers. If you only have one telephone line, this phone will still operate, but only as a single line telephone.

5. Connect the handset cord:

Plug one end of the coiled handset cord into the side of the base and the other end into the jack on the handset, and place the handset in the cradle.

6. Check for a dial tone. Lift the handset and listen for a dial tone. If you hear a dial tone, the phone is properly installed.

Data Port

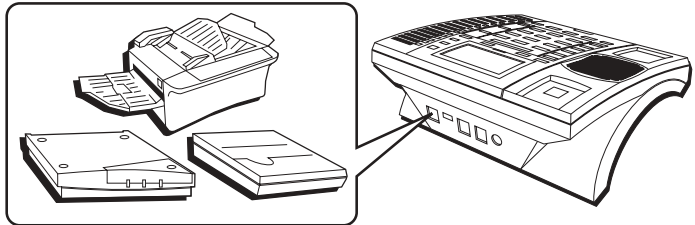

This phone has a DATA PORT jack to connect an auxiliary phone device, such as a fax machine, computer modem, answering machine, or even a cordless phone.

The DATA PORT switch on the back of the phone controls the DATA PORT jack so you can choose line 1 or line 2.

Use the DATA PORT jack to hook up your fax machine, for example, and then set the DATA PORT switch to 2 in order to receive faxes on the phone number for line 2.

If you are talking to someone on line 2 and want them to fax something to you, change the DATA PORT switch to 1 and give him the phone number for line 1. Your fax machine can now receive calls on line 1.

IMPORTANT: Be sure to switch the fax machine back to the normal line when you are done because outside callers who do not know that you have multiple lines will not be able to reach your fax machine if they dial the normal fax line.

Programming the Telephone

Display Language

You may set the display language to English, French, or Spanish. The default is English.

1. Press the MENU button. *LANGUAGE* is displayed
2. Press SELECT.
3. Use the REVIEW ◀ or ▶ button to select the language.
4. When finished, press SELECT to save. To start over, press EXIT to return to the *LANGUAGE* menu and repeat step 2.

Manually Setting the Date and Time

NOTE: If you do not manually set the time and date, it is automatically set when you receive your first Caller ID call. The unit resets the hour and minute each time a call is received.

1. Press the MENU button.
2. Use the REVIEW ◀ or ▶ button to scroll to *TIME & DATE*.
3. Press SELECT.
4. Use the REVIEW ◀ or ▶ button to scroll to the desired hour.
5. Press SELECT to save. The cursor moves to the minute field.
6. Use the REVIEW ◀ or ▶ button to select the minute.
7. Press SELECT to save. The cursor moves to the month field.
8. Use the REVIEW ◀ or ▶ button to select the month.
9. Press SELECT to save. The cursor moves to the date field.
10. Use the REVIEW ◀ or ▶ button to select the date.
11. Press SELECT to save. To start over, press EXIT to return to the *TIME & DATE* menu.

Connections and Setup

Flash Time

Depending on the services you have with the phone company, you may need to adjust the flash timing. It can be set from 100ms or 600ms. The default is 600ms.

1. Press the MENU button.
2. Use the REVIEW ◀ or ▶ to scroll to *PHONE OPTIONS*.
3. Press SELECT.
4. Use the REVIEW ◀ or ▶ to scroll to *FLASH TIME*.
5. Press SELECT.
6. Use the REVIEW ◀ or ▶ to scroll to the desired setting.
7. Press SELECT to save. To start over, press EXIT to return to the *FLASH TIME* menu.

Hour Format

You can set the clock for either 12-hour or 24-hour (military) format. The default is 12 hour.

1. Press the MENU button.
2. Use the REVIEW ◀ or ▶ to scroll to *PHONE OPTIONS*.
3. Press SELECT.
4. Use the REVIEW ◀ or ▶ to scroll to *HOUR FORMAT*.
5. Press SELECT. To start over, press EXIT to return to the *PHONE OPTIONS* menu.
6. Use the REVIEW ◀ or ▶ to scroll between *12 HOUR* and *24 HOUR*.
7. Press SELECT to save. To start over, press EXIT to return to the *HOUR FORMAT* menu.

Call Alert Tone

When the call alert tone is turned ON, you hear a call alert tone when you are on the phone and you receive a call on the other line. If you prefer to have incoming calls not interrupt or disturb your ongoing conversation, set the Call Alert Tone to OFF. The default is ON.

1. Press the MENU button.
2. Use the REVIEW ◀ or ▶ button to scroll to *PHONE OPTIONS*.
3. Press SELECT button.
4. Use the REVIEW ◀ or ▶ button to scroll to *CALL ALERT*.
5. Press SELECT button.
6. Use the REVIEW ◀ or ▶ button to scroll to *ON* or *OFF*.
7. Press SELECT to save. To start over, press EXIT to return to the *CALL ALERT* menu.

Local Area Code

1. Press the MENU button.
2. Use the REVIEW ◀ or ▶ button to scroll to *AREA CODE*.
3. Press SELECT. *ENTER DIGIT* is displayed.
4. Use the touch-tone pad to enter your area code.

NOTE: If you make a mistake, press DELETE to clear all three digits and re-enter the area code.

5. When finished, press SELECT to save. To start over, press EXIT to return to the *AREA CODE* menu and repeat step 3.

Regional Area Codes

Depending on your area, you may need to set regional area codes. These are needed in order for the phone to determine the number format to display when a valid CID signal is received. Calls received that match any of the regional area codes display as 10 digits. If the number is not displayed correctly, the phone may not be able to dial back the number. You can store up to 6 regional area codes.

You may need to use this feature if you have:

- Multiple area codes
- Overlapping area codes
- Areas that require 10-digit dialing.

1. Press the MENU button.
2. Use the REVIEW ◀ or ▶ button to scroll to *REGION CODE*.
3. Press SELECT.
4. Use the REVIEW ◀ or ▶ to scroll to desired code #.
5. Press SELECT.
6. Use the touch-tone pad to enter the code. Press DELETE to clear and re-enter all three digits.
7. When finished, press SELECT to save and return to *CODE # x*.

Display Contrast

1. Press the MENU button.
2. Use the REVIEW ◀ or ▶ to scroll to *CONTRAST*.
3. Press SELECT. "-----" is displayed to show the current contrast level.
4. Use the REVIEW ◀ or ▶ to increase or decrease the display contrast.
5. When finished, press SELECT to save. To start over, press EXIT to return to the *CONTRAST* menu and repeat step 3.

Voice Mail Access Codes

You can program a voice mail access code for each telephone line for quick access to your voice mail.

1. Press the MENU button.
2. Use the REVIEW ◀ or ▶ button to scroll to *VM CODE*.
3. Press SELECT.
4. Use the REVIEW ◀ or ▶ button to scroll between *L1 VM CODE* and *L2 VM CODE*.
5. Press SELECT.
6. Use the touch-tone pad to enter your voice mail access phone number.
 - Use the REVIEW ◀ or ▶ button to move the cursor in the display.
 - Use the DELETE button to erase a mistake and re-enter the correct digit.
7. Press SELECT to save. To start over, press EXIT to return to *Lx VM CODE* menu.

Restoring the Defaults

This feature allows you to reset all the menu settings to the original default settings.

1. Press the MENU button.
2. Use the REVIEW ◀ or ▶ to scroll to *RESTORE SET*.
3. Press SELECT.
4. Use the REVIEW ◀ or ▶ to scroll to *YES*.
5. Press SELECT to save. To start over, press EXIT to return to the *RESTORE SET* menu.

Telephone Operation

Telephone Operation

Making Calls with the Handset

1. Pick up the handset and the phone automatically selects an open line.
2. Wait for a dial tone.
3. Dial a phone number.
4. Hang up the handset when finished.

Making Calls with the Speakerphone

1. Press the SPEAKER button and the phone automatically selects an open line.
2. Wait for a dial tone.
3. Dial a phone number.
4. Press SPEAKER when finished.

Making Calls with the Optional Headset

1. Connect a headset to the HEADSET jack on the side of the base.
2. Adjust the headset to rest comfortably on top of your head and over your ear.
3. Move the microphone to approximately 2 to 3 inches from your mouth.
4. Press the HEADSET button, and the phone automatically selects an open line.
5. Wait for a dial tone.
6. Dial a phone number.
7. Press HEADSET when finished.

NOTE: To converse using the headset, the handset must be placed in the cradle.

Receiving Calls with the Handset

When the phone rings, the corresponding line's indicator flashes rapidly.

1. Pick up the handset (your phone automatically selects the ringing line).
2. When you are finished, hang up the handset.

Receiving Calls with the Speakerphone

When the phone rings, the corresponding line's indicator flashes rapidly.

1. Press the SPEAKER button. The speakerphone turns on and automatically selects a line.
2. When you are finished, press SPEAKER.

Receiving Calls with the Optional Headset

When the phone rings, the corresponding line's indicator flashes rapidly.

1. Press the HEADSET button, and the phone automatically selects the line using the headset.
2. When you are finished, press HEADSET.

NOTE: Whether you are making or receiving a call, the caller is disconnected if you press another line without putting the call on hold first.

NOTE: To converse using the headset, the handset must be placed in the cradle.

Switching Between the Speakerphone, Handset, and Headset

To switch to the speakerphone, press SPEAKER. The speakerphone indicator turns on.

To switch to the handset, pick up the handset. The speakerphone or headset turns off.

To switch to the headset, press HEADSET. The headset indicator turns on. Place the handset in the cradle.

Telephone Operation

Pre-Dialing Telephone Numbers

Pre-dialing lets you to enter , check , and edit a telephone number before engaging the line. There are several ways to pre-dial a telephone number:

- Manually enter the telephone number, or
- Press one of the 16 memory location buttons, or
- Press DIRECTORY, followed by the REVIEW ◀ or ▶ button to search the phone book memory.
- Press the REVIEW ◀ or ▶ buttons to scroll the CID memory, or
- Press the REDIAL button.

Then -

1. Press the DIAL button. The phone automatically selects a line and turns on the speakerphone.
2. Dial the number showing in the display.

Call Timer

During a phone conversation, a built-in call timer displays the length of the call in minutes and seconds. When the call is finished, total time shows in the display for about 10 seconds. A call is timed even while it is on hold.

Mute

To have a private, off-line conversation, use the MUTE feature. The party on the telephone line cannot hear you. A conversation can be muted during speakerphone, handset, or headset use.

1. Press MUTE. The mute indicator turns on.
2. Press MUTE to cancel and return to your phone conversation

NOTE: Switching from speakerphone to handset or headset cancels mute.

Hold

Placing a Call on Hold

1. Press HOLD. The indicator for the line on hold flashes green.
2. Hang up or press another line button.

Releasing a Call from Hold

Press the line button for the call on hold. The phone automatically goes into speakerphone mode.

NOTE: If you want to change modes, lift the handset to switch to the handset, or press the HEADSET button to use the headset.

Flash

Use the FLASH button to activate custom calling services such as Call Waiting, which is available through your local telephone company.

Redial

To quickly redial the last number you dialed (up to 32 digits):

1. Pick up the handset, or press SPEAKER or HEADSET.
2. The line is selected automatically.
3. Wait for a dial tone.
4. Press REDIAL.

Volume

The ringer, speaker, and handset/headset volumes can be set independently. Your telephone is preset but may be set to individual taste. To return to the default settings, press both the VOLUME ▲ or ▼ buttons simultaneously.

Telephone Operation

Ringer Volume

While the handset is on the cradle tap the VOLUME ▲ or ▼ button to increase or decrease the ringer loudness. The phone generates a sample ring at the selected setting.

Speakerphone, Handset, and Headset Volume

While using the phone press the VOLUME ▲ or ▼ buttons to set the volume to a comfortable level. The phone stores the setting when you release the button.

Conference

This feature lets you connect two calls to make a conference call.

To connect with two calls:

1. Press any line button. If you already have someone on the line, skip to step 2.
2. Press HOLD.
3. Press the another line button to answer or make a second call
4. When the second call connects, press CONFER.

To **disconnect one line**, press the line button for the party you want to continue talking with and the other party is automatically disconnected.

To **disconnect both lines**, hang up the handset or press SPEAKER if you are using the speakerphone or press HEADSET if you are using the headset.

To **keep both parties on-line but talk to one party**:

1. Press the HOLD button to place both lines on hold.
2. To talk with one caller, press the corresponding line button. The other line remains on hold.
3. To resume the conference call with both lines, press CONFER.

Do Not Disturb

This feature disables an incoming call ring, within the time duration you selected. You can program the do not disturb duration.

1. While the handset is on the cradle, press DND button. The DND indicator flashes.

2. Use the REVIEW ◀ or ▶ button to select the duration. You may choose from 15 minutes, 30 minutes, 45 minutes, 1 hour, or 2 hours and increase the duration by 1 hour intervals up to 24 hours.
3. Press the SELECT button to save your selection.
4. When the Do Not Disturb function is on, the DND indicator flashes. To turn off Do Not Disturb, press the DND button.

NOTE: When Do Not Disturb is On, you will still receive a ringing line indication, CID information, and New Call indicators.

Voice Messaging

Provided your phone company offers voice messaging service and you subscribe to it, the VOICE MAIL indicator on the base flashes to indicate a message is waiting. It stops flashing after the message is reviewed.

IMPORTANT: You must have the voice mail access code programmed for this feature to work. See "Voice Mail Access Codes."

1. Pick up the handset, or press HEADSET or SPEAKER.
2. Press VOICE MAIL 1 for line 1 voicemail or VOICE MAIL 2 for line 2 voicemail.
3. The unit auto dials the pre-programmed voice mail access number/code so you can access the voice mail stored at the phone company.

The user can also review the access number first before dialing.

1. Press VOICE MAIL 1 for line 1 voicemail or VOICE MAIL 2 for line 2 voicemail.
2. The number shows in the display.
3. Pick up the handset, press HEADSET, or press SPEAKER.
4. The unit auto dials the pre-programmed voice mail access number so you can access the voice mail stored at the phone company.

Caller ID (CID)

Summary Screen

The summary screen shows the current time, current date and number of new calls to be reviewed. It is displayed until any button is pressed. Within 10 seconds of receiving a new call, the new caller information is displayed and the green NEW CALL indicator turns on.

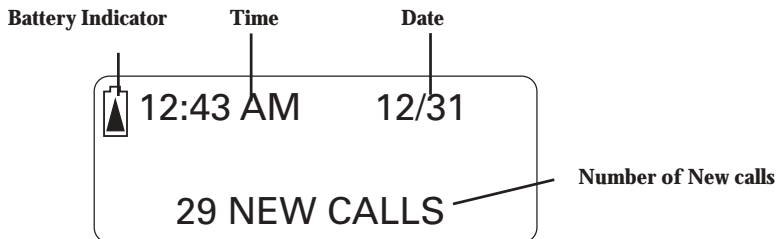

NOTE: The number of new calls is displayed until all new calls have been reviewed.

Receiving and Storing CID Records

This unit receives and displays information transmitted by your local phone company. This information can include the phone number, date, and time; or the name, phone number, date, and time. The unit stores up to 99 call records for later review. When the call log is full, a new call automatically replaces the oldest call. *NEW* appears in the display for calls received that have not been reviewed.

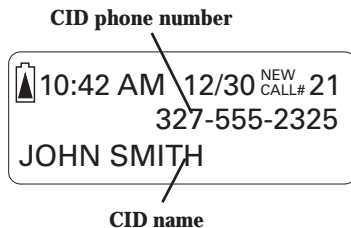

Reviewing CID Records

- Press the REVIEW ◀ or ▶ to scroll the call records.

NOTE: When you scroll to the start/end of the list, START /END appears in the display.

Saving CID Records to Memory/Phone Directory Memory

1. While a name and telephone number shows in the display, press SELECT if you want to edit the information. Then follow the steps in the Storing a Name and Number in Memory section to edit and store the record.
2. If you do not need to edit the name or number, press the STORE button followed by the MEMORY button, or press the DIRECTORY button to save the information in the Phone Directory memory.

Deleting a CID Record

To delete the record showing in the display, press the DELETE button once.

Deleting All CID Records

This feature allows you to clear all CID records at once.

1. While viewing the CID record, press and hold the DELETE button for two seconds. *DELETE ALL?* shows in the display.
2. Press the DELETE button again to confirm.

Dialing Back

When reviewing CID records, you can dial back the numbers showing on the display.

If You Programmed Your Local Area Code in the Setup Menu

1. Press the REVIEW ◀ or ▶ button to scroll to the number you want to dial.
2. Press the DIAL button. If you see a number with 7 digits (i.e. 555-1234), then the call was received from within your area code. However, this does not guarantee the call is a local call. If you see a number with 11 digits (i.e. 1-234-555-1234), then the call received was not from your area code. If the viewing number is not a Direct Dial Number provided by the phone company, the unit displays ◀ ▶ *TO ADJUST*.

Caller ID

3. To adjust the phone number format, use the REVIEW ◀ or ▶ button. For instance, a 7-digit local number sometimes cannot be dialed because it requires a 10-digit or 11-digit format. Use the REVIEW ◀ or ▶ button to scroll through 7, 10, and 11-digit numbers.

7-digits: 7-digit telephone number (i.e. 555-5555)

10-digits: 3-digit area code + 7-digit telephone number (i.e. 425-555-5555)

11-digits: long distance code 1 + 3-digit area code + 7-digit telephone number (i.e. 1-425-555-5555)

4. To dial the displayed number, pick up the handset or press DIAL again.

If You Did Not Program Your Local Area Code in the Setup Menu

1. Press the REVIEW ◀ or ▶ button to display the number you want to dial. You will only see 10-digit numbers (i.e. 234-555-1234).
2. Press DIAL to dial back. You may adjust the number format if ◀ ▶ *TO ADJUST* shows in the display.

Call Waiting Caller ID

This feature lets you see (in the display) who is calling when you are on the phone and hear the call waiting tone in the receiver. The caller identification information appears in the display after you hear the tone.

IMPORTANT: In order to use this unit, you must subscribe to either the standard Name/Number Caller ID Service or Caller ID with Call Waiting Service. To know who is calling while you are on the phone, you must subscribe to Caller ID with Call Waiting Service.

Direct Access Memory & Directory Memory

Storing a Name and Number in Memory

1. Press the STORE button. *ENTER NUMBER* shows in the display.
2. Use the touch-tone pad to enter the number you want to store (up to 32 digits).

NOTE: If you make a mistake, use the ◀ ▶ button to position the cursor and press DELETE to erase an incorrect digit OR directly input another digit to replace the incorrect digit.

3. Press the SELECT button.
4. Use the touch-tone pad to enter a name (up to 21 characters). More than one letter is stored in each of the number keys. For example, to enter Bill Smith, press the 2 key twice for the letter B. Press the 4 key 3 times for the letter I. Press the 5 key 3 times for the letter L. Press the 5 key 3 times for the second letter L, and press the 1 key to insert a space between the first and last name. Press the 7 key 4 times for the letter S; press the 6 key once for the letter M; press the 4 key 3 times for the letter I; press the 8 key for the letter T; press the 4 key twice for the letter H.

NOTE: If you make a mistake, press DELETE to erase an incorrect letter and re-enter the correct letter.

5. Press the STORE button. *LOCATION?* shows in the display.
6. Enter the memory location :
 - Press the DIRECTORY button to save the record in Directory MemoryOR
 - Press a MEMORY button to save the record in Direct Access Memory.
7. For future reference, write the name or number of the parties stored in each location on the corresponding spaces on the memory index card.

Reviewing Stored Names & Numbers

1. Press the DIRECTORY button.
2. Use the REVIEW ◀ or ▶ button to review the records stored in Directory Memory.

OR

Memory

1. Press a MEMORY button to review the record stored in Direct Access Memory.

Changing a Stored Name or Number

1. Press DIRECTORY.
2. Use the REVIEW ◀ or ▶ button to scroll to the desired memory.
3. Press SELECT and edit the content according to the steps in the Storing a Name & Number in Memory section.

OR

1. Press a MEMORY location button.
2. Press SELECT and edit the content according to the steps in the Storing a Name and Number in Memory section.

Storing the Last Number Dialed

To quickly and easily store the last number dialed.

1. Press the REDIAL/PAUSE button to view the last number dialed.
2. Press SELECT if you want to edit the number, otherwise press STORE.
3. Follow the steps in the Storing a Name and Number in Memory section to store the number.

Storing a Pause

Use the PAUSE button to insert a pause when a delay is needed in the dialing sequence (for example, when you must dial a 9 to get an outside line or when you must enter codes to access your bank's information line).

Storing a Flash

Press the FLASH button to insert a flash while you enter a number in the Storing a Name and Number in Memory process.

Dialing a Stored Number

If the number is stored in the Directory Memory,

1. Pick up the handset, or press SPEAKER or HEADSET.
2. Wait for the dial tone.
3. Press the DIRECTORY button, and use the REVIEW ◀ or ▶ button to find the number.
4. Press the DIAL button and the number automatically dials.

If the number is stored in the Direct Access Memory,

1. Pick up the handset, or press SPEAKER or HEADSET.
2. Wait for the dial tone.
3. Press the MEMORY location button, and the number automatically dials.

Chain Dialing

This process allows you to dial a succession of stored numbers from separate memory locations. This is useful when you must dial several sequences of numbers, such as with frequent calls via a telephone company long distance provider.

For example

Memory location

Local access number of long distance company	6
Authorization code (ID)	7
Long distance phone number	8

Using

1. Press the line you want.
2. Press memory location 6. (Press pause if needed.)
3. Press memory location 7. (Press pause if needed.)
4. Press memory location 8.

Deleting All Directory Memory

This feature allows you to clear all memory saved in the directory at once.

1. Press the MENU button.
2. Use the REVIEW ◀ or ▶ buttons to scroll to *PHONE OPTIONS*
3. Press SELECT. *CLEAR ALL MEM* shows in the display.
4. Press SELECT.
5. Press the REVIEW ◀ or ▶ button to scroll to *YES*.
6. Press SELECT. *OK* is displayed to confirm all directory memory is deleted. If you want to start over, press EXIT once to return to the previous menu level.

Display Messages

The following special messages indicate the status of a message or the unit:

- NO CALLS** The CID memory log is empty.
- UNKNOWN CALLER** The incoming call does not have CID service or their service area is not linked to yours. If *UNKNOWN CALLER* appears along with a calling number, the name information for that number was not available.
- BLOCKED CALL** The caller is registered as "Private Number" and their CID information is withheld.
- INCOMPLETE DATA** Caller information has been interrupted or corrupted during transmission.
- NO DATA** No CID signal has been detected, or CID service has not been activated.
- START/END** You are at the beginning or the end of the CID memory log.



Battery power level is low or battery is not installed.

Troubleshooting Guide

No dial tone

- Check or repeat installation steps:
 - Make sure the telephone line cords are connected to the phone and the wall jack .
 - Make sure the cords are not damaged .
- Make sure the hook switch pops up when the handset is lifted .
- Check the SPEAKER button. Is the indicator off?
- Disconnect the phone from the wall jack and connect another phone to the same jack. If there is no dial tone in the second phone, the problem might be your wiring or local service.

Other Information

You cannot be heard by the other party.

- Make sure the handset or headset cord is connected properly and securely.
 - Make sure MUTE is not turned on.
-

Phone does not ring.

- Make sure the ringer is turned on.
 - You may have too many extension phones on your line. Try unplugging some phones.
 - See solutions for “No dial tone.”
-

Phone does not ring

- Make sure Do Not Disturb is not turned on.
-

Incoming voice too low or none at all.

- Check and adjust volume control setting.
-

Memory dialing doesn't work

- Make sure you program the memory location keys correctly .
 - Make sure you follow proper dialing sequence .
-

Battery LOW indicator blinks or is solid

- The batteries need replacing or are not installed.
-

General Product Care

To keep your telephone working and looking good, follow these guidelines:

- Avoid putting the phone near heating appliances and devices that generate electrical noise (for example, motors or fluorescent lamps).
- DO NOT expose to direct sunlight or moisture.
- Avoid dropping the handset, as well as other rough treatment to the phone.
- Clean the phone with a soft cloth.
- Never use a strong cleaning agent or abrasive powder because this will damage the finish.
- Retain the original packaging in case you need to ship the phone at a later date.

Other Information

Service

If trouble is experienced with this equipment, for repair or warranty information, please contact customer service at **1-800-511-3180**. If the equipment is causing harm to the telephone network, the telephone company may request that you disconnect the equipment until the problem is resolved.

This product may be serviced only by the manufacturer or its authorized service agents. Changes or modifications not expressly approved by ATLINKS USA, Inc. could void the user's authority to operate this product. For instructions on how to obtain service, refer to the warranty included in this guide or call customer service at **1-800-511-3180**.

Or refer inquiries to:

ATLINKS USA, Inc.

Manager, Consumer Relations

P O Box 1976

Indianapolis, IN 46206

Attach your sales receipt to the booklet for future reference or jot down the date this product was purchased or received as a gift. This information will be valuable if service should be required during the warranty period.

Purchase date _____

Name of store _____

Limited Warranty

What your warranty covers:

- Defects in materials or workmanship.

For how long after your purchase:

- One year, from date of purchase.

(The warranty period for rental units begins with the first rental or 45 days from date of shipment to the rental firm, whichever comes first.)

What we will do:

- Provide you with a new or, at our option, a refurbished unit. The exchange unit is under warranty for the remainder of the original product's warranty period.

How you get service:

- Properly pack your unit. Include any cables, etc., which were originally provided with the product. We recommend using the original carton and packing materials.
- "Proof of purchase in the form of a bill of sale or receipted invoice which is evidence that the product is within the warranty period, must be presented to obtain warranty service." For rental firms, proof of first rental is also required. Also print your name and address and a description of the defect. Send via standard UPS or its equivalent to:

ATLINKS USA, Inc.
c/o Thomson
11721 B Alameda Ave.
Socorro, Texas 79927

- Pay any charges billed to you by the Exchange Center for service not covered by the warranty.
- Insure your shipment for loss or damage. ATLINKS accepts no liability in case of damage or loss.
- A new or refurbished unit will be shipped to you freight prepaid.

What your warranty *does not* cover:

- Customer instruction. (Your Owner's Manual provides information regarding operating instructions and user controls. Any additional information, should be obtained from your dealer.)
- Installation and setup service adjustments.
- Batteries.
- Damage from misuse or neglect.
- Products which have been modified or incorporated into other products.
- Products purchased or serviced outside the USA.
- Acts of nature, such as but not limited to lightning damage.

Product Registration:

- Please complete and mail the Product Registration Card packed with your unit. It will make it easier to contact you should it ever be necessary. The return of the card is not required for warranty coverage.

Other Information

Limitation of Warranty:

- THE WARRANTY STATED ABOVE IS THE ONLY WARRANTY APPLICABLE TO THIS PRODUCT. ALL OTHER WARRANTIES, EXPRESS OR IMPLIED (INCLUDING ALL IMPLIED WARRANTIES OF MERCHANTABILITY OR FITNESS FOR A PARTICULAR PURPOSE) ARE HEREBY DISCLAIMED. NO VERBAL OR WRITTEN INFORMATION GIVEN BY ATLINKS USA, INC., ITS AGENTS, OR EMPLOYEES SHALL CREATE A WARRANTY OR IN ANY WAY INCREASE THE SCOPE OF THIS WARRANTY.
- REPAIR OR REPLACEMENT AS PROVIDED UNDER THIS WARRANTY IS THE EXCLUSIVE REMEDY OF THE CONSUMER. ATLINKS USA, INC. SHALL NOT BE LIABLE FOR INCIDENTAL OR CONSEQUENTIAL DAMAGES RESULTING FROM THE USE OF THIS PRODUCT OR ARISING OUT OF ANY BREACH OF ANY EXPRESS OR IMPLIED WARRANTY ON THIS PRODUCT. THIS DISCLAIMER OF WARRANTIES AND LIMITED WARRANTY ARE GOVERNED BY THE LAWS OF THE STATE OF INDIANA. EXCEPT TO THE EXTENT PROHIBITED BY APPLICABLE LAW, ANY IMPLIED WARRANTY OF MERCHANTABILITY OR FITNESS FOR A PARTICULAR PURPOSE ON THIS PRODUCT IS LIMITED TO THE APPLICABLE WARRANTY PERIOD SET FORTH ABOVE.

How state law relates to this warranty:

- Some states do not allow the exclusion nor limitation of incidental or consequential damages, or limitations on how long an implied warranty lasts so the above limitations or exclusions may not apply to you.
- This warranty gives you specific legal rights, and you also may have other rights that vary from state to state.

If you purchased your product outside the USA:

- This warranty does not apply. Contact your dealer for warranty information.

A

Accessory Order Form 37

B

Base Layout 6

C

Call Alert Tone 13

Call Timer 18

Call Waiting Caller ID 24

Caller ID (CID) 22

Chain Dialing 27

Changing a Stored Name or
Number 26

Conference 20

Connections and Setup 6

D

Data Port 10

Deleting a CID Record 23

Deleting All CID Records 23

Deleting All Directory

Memory 28

Dialing a Stored

Number 27

Dialing Back 23

Direct Access Memory &

Directory Memory 25

Display Contrast 14

Display Language 11

Display Messages 29

Do Not Disturb 20

E

Equipment Approval
Information 2

F

Flash 19

Flash Time 12

H

Hold 19

Hour Format 12

I

If You Did Not Program
Your Local Area Code
in the Setup Menu 24

If You Programmed Your
Local Area Code in the
Setup Menu 23

Important Information 2

Important Installation

Information 7

Installation 7

Installing the Phone 8

Interference Information 2

Introduction 5

L

Limited Warranty 33

Local Area Code 13

M

Making Calls with the
Handset 16

Making Calls with the
Optional Headset 16

Making Calls with the
Speakerphone 16

Manually Setting the Date
and Time 11

Mute 18

P

Parts Checklist 7

Placing a Call on Hold 19

Pre-Dialing Telephone
Numbers 18

Programming the Telephone
11

R

- Receiving and Storing CID Records 22
- Receiving Calls with the Handset 17
- Receiving Calls with the Optional Headset 17
- Receiving Calls with the Speakerphone 17
- Redial 19
- Regional Area Codes 14
- Removing a Call from Hold 19
- Restoring the Defaults 15
- Reviewing CID Records 23
- Reviewing Stored Names & Numbers 25
- Ringer Volume 20

S

- Saving CID Records to Memory/Phone Directory Memory 23
- Service 32
- Speakerphone, Handset, and Headset Volume 20
- Storing a Flash 26
- Storing a Name and Number in Memory 25
- Storing a Pause 26
- Storing the Last Number Dialed 26
- Summary Screen 22
- Switching Between the Speakerphone, Handset, and Headset 17

T

- Telephone Basics 16
- Telephone Jack Requirements 7
- Troubleshooting Guide 29

V

- Voice Mail Access Codes 15
- Voice Messaging 21
- Volume 19

Accessory Order Form

To Order

To place your order by phone, have your Visa, MasterCard or Discover Card ready and call the toll-free number listed below.

Use this number only to place an order for accessory items listed on this order form.

1-800-338-0376

To place your order by mail, detach and mail the completed order form with credit card information, money order or check in US currency (made payable to Thomson multimedia Inc.) to the following address:

Thomson Inc.
 Mail Order Department
 PO Box 8419
 Ronks, PA 17573-8419

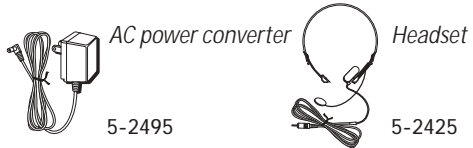

Description	Part No.	Price	Qty	Total
AC power converter	5-2495	\$20.85		
Headset	5-2425	\$19.95		

Charge your order on your VISA, MasterCard, or Discover Card by filling in below

USE YOUR CREDIT CARD

IMPORTANT: Copy complete account number from your VISA card



□ □ □ □ □ □ □ □ □ □ □ □ □ □ □ □

My card expires: □ □ □ □

IMPORTANT: Copy complete account number from your MasterCard



□ □ □ □ □ □ □ □ □ □ □ □ □ □ □ □

Copy Number above your name on MasterCard: □ □ □ □ □ □ □ □ □ □ My card expires: □ □ □ □

IMPORTANT: Copy complete account number from your Discover Card



□ □ □ □ □ □ □ □ □ □ □ □ □ □ □ □

My card expires: □ □ □ □

AUTHORIZED SIGNATURE
 (Credit card order will not be processed without signature)

Print or type your name and address clearly.  A complete and correct order will save you days of waiting.

Name: _____
 Street: _____
 _____ Apt: _____
 City: _____
 State: _____ Zip: _____
 Daytime phone number: _____

Prices are subject to change without notice.

Total Merchandise..... \$ _____
 Sales Tax..... \$ _____

We are required by law to collect the appropriate sales tax for each individual state, county, and locality to which the merchandise is being sent.

Shipping and Handling..... \$ 5.00
 Total Amount Enclosed..... \$ _____

Use VISA, MasterCard, or Discover Card preferably.
 Money order or check must be in U.S. currency only.
 No COD or CASH.

All accessories are subject to availability.
 Where applicable, we will ship a superseding model.

Detach Here >

Visit the RCA web site at www.rca.com

Please do not send any products to the Indianapolis address listed in this manual or on the carton. This will only add delays in service for your product.

ATLINKS USA, Inc.

101 West 103rd Street
Indianapolis, IN 46290

©2003 ATLINKS USA, Inc.

Trademark(s)[®] Registered

Marca(s) Registrada(s)

Model 25202

TOCOM 16211370 (Rev. 0 E/S)

03-43

Printed in China

Free Manuals Download Website

<http://myh66.com>

<http://usermanuals.us>

<http://www.somanuals.com>

<http://www.4manuals.cc>

<http://www.manual-lib.com>

<http://www.404manual.com>

<http://www.luxmanual.com>

<http://aubethermostatmanual.com>

Golf course search by state

<http://golfingnear.com>

Email search by domain

<http://emailbydomain.com>

Auto manuals search

<http://auto.somanuals.com>

TV manuals search

<http://tv.somanuals.com>