

User's Guide

3922 496 30571 November 2007 v3.0

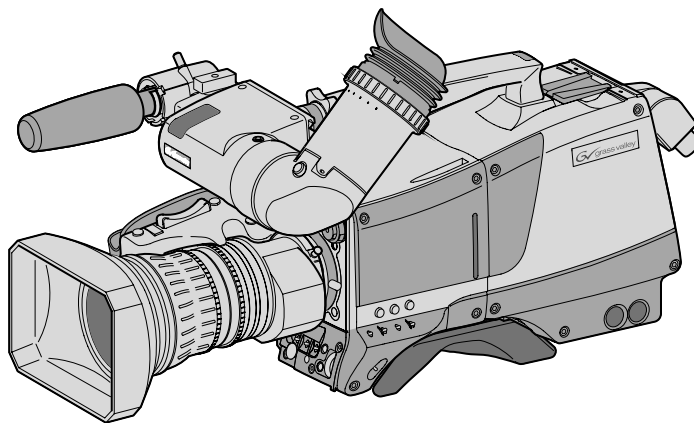

LDK 8000 HDTV camera system

Standard version

WorldCam version

SportCam version



Declaration of Conformity

We, Grass Valley Nederland B.V., Kapittelweg 10, 4827 HG Breda, The Netherlands, declare under our sole responsibility that this product is in compliance with the following standards:

- EN60950 : Safety
- EN55103-1: EMC (Emission)
- EN55103-2: EMC (Immunity)

following the provisions of:

- a. the Low Voltage directive 2006/95/EC
- b. the EMC directive 2004/108/EC

FCC Class A Statement

This product generates, uses, and can radiate radio frequency energy and if not installed and used in accordance with the instructions, may cause interference to radio communications.

It has been tested and found to comply with the limits for a class A digital device pursuant to part 15 of the FCC rules, which are designed to provide reasonable protection against such interference when operated in a commercial environment.

Operation of this product in a residential area is likely to cause interference in which case the user at his own expense will be required to take whatever measures may be required to correct the interference.

Copyright

Copyright Grass Valley Nederland B.V. 2007. Copying of this document and giving it to others, and the use or communication of the contents thereof, are forbidden without express authority. Offenders are liable to the payment of damages. All rights are reserved in the event of the grant of a patent or the registration of a utility model or design. Liable to technical alterations in the course of further development.

Trademarks

Grass Valley and Infinity are trademarks of Grass Valley, Inc. All other tradenames referenced are service marks, trademarks, or registered trademarks of their respective companies.

Website

Visit the Grass Valley public website to download the latest user's guide updates and additional information about your broadcast product:

www.thomsongrassvalley.com

Table of contents

Chapter 1 – Introduction

1.1	Technology	13
1.1.1	HD sensors	13
1.1.2	Digital processing	13
1.1.3	Film-like characteristics	14
1.1.4	Focus assist	14
1.1.5	Standard version	14
1.1.6	SportCam version	14
1.1.7	WorldCam version	15
1.1.8	Advanced TriaxHD features	15
1.1.9	SuperXPander	16
1.2	Features	16
1.3	Accessories	18

Chapter 2 – Installation

2.1	Packing/unpacking	19
2.2	Transport case	20
2.3	Mounting a lens	21
2.4	2-inch viewfinder	22
2.4.1	Mounting viewfinder and microphone holder	22
2.4.2	Positioning the viewfinder	23
2.5	Viewfinder accessories	24
2.5.1	Wide angle eyepiece	24
2.5.2	Left eye adapter	24
2.6	Mounting a microphone	25
2.7	Tripod adapter plate	26
2.8	Adjusting the shoulder pad	27
2.9	Attaching an adapter	28

Chapter 3 – Configurations

3.1	TriaxHD mode	29
3.2	Multiple TriaxHD cameras with C2IP network	30
3.3	Camera with TriaxHD adapter and SuperXPander	31
3.4	SportCam with high-speed Base Station	32
3.5	Local mode	33
3.6	Triax cable lengths	34

Chapter 4 – Location of controls

4.1	Camera head controls and connectors	35
4.2	TriaxHD adapter controls and connectors	38
4.3	Viewfinder controls and indicators	40

Chapter 5 – Operating instructions

5.1	Using the camera	41
5.1.1	Switching on the power	41
5.1.2	Controlling the camera	41
5.2	System Menu	42
5.2.1	Entering the System menu	42
5.2.2	Finding your way	43
5.2.3	Leaving the System Menu	44
5.2.4	Making changes	44
5.2.5	Undoing changes	44
5.3	Assigning functions to buttons	45
5.3.1	Side panel	45
5.3.2	Front	45
5.3.3	Lens	45
5.4	Video acquisition modes	46
5.4.1	LDK 8000 Standard version	46
5.4.2	LDK 8000 SportCam version	46
5.4.3	LDK 8000 WorldCam version	47
5.5	Viewfinder preferences	48
5.5.1	Viewfinder picture quality	48
5.5.2	Video level indication	48
5.5.3	Tally indicators	48
5.5.4	Viewfinder markers	49
5.5.5	Focussing	49
5.6	Lens preferences	50
5.6.1	Lens type	50
5.6.2	Auto iris	50
5.6.3	Extended iris	50
5.6.4	Precision focus	51
5.6.5	Lens indicators in the viewfinder	51
5.7	Video preferences	52
5.7.1	Standard settings	52
5.7.2	Test signal	53
5.7.3	Gain selection	53
5.7.4	Optical filter selection	54
5.7.5	Colour temperature selection	55
5.7.6	Exposure time	58
5.7.7	Shooting screens	59
5.7.8	Reverse scan	60
5.7.9	Black stretch	60
5.7.10	Auto skin detail	60
5.8	Controls on the TriaxHD adapter	61
5.8.1	Powering the camera	61
5.8.2	Selecting monitoring signals	62
5.8.3	Using audio	63
5.8.4	Intercom	65
5.8.5	Communication	66
5.9	Managing files	67
5.9.1	Scene files	67
5.9.2	Operator files	67
5.9.3	Standard files	67
5.9.4	Customer standard files	68

5.10	User levels	68
5.10.1	Selecting the user level	68
5.11	Access and Security	69
5.11.1	Camera cards	69
5.11.2	Access control	70
5.11.3	Camera card slot	70

Chapter 6 – Menu structure and contents

6.1	Menu structure	71
6.1.1	Top menu structure	71
6.1.2	VF menu structure	72
6.1.3	Lens menu structure	73
6.1.4	Video menu structure	74
6.1.5	Install menu structure (Triax version)	75
6.1.6	File menu structure	76
6.1.7	Security menu structure	77
6.1.8	Diagnostics menu structure	77
6.1.9	Service menu structure	77
6.2	Menu contents	78
6.2.1	VF menu	78
6.2.2	Lens menu	80
6.2.3	Video menu	81
6.2.4	Install menu	85
6.2.5	Files menu	89
6.2.6	Security menu	90
6.2.7	Diagnostics menu	91
6.2.8	Service menu	93

Chapter 7 – Connectors

7.1	Camera connectors	95
7.1.1	Viewfinder connector	96
7.1.2	VF/Mon connector	96
7.1.3	Lens connector	97
7.1.4	Audio microphone connector	97
7.1.5	RS232 serial connector	97
7.2	Connectors on the TriaxHD adapter	98
7.2.1	Triax connector	99
7.2.2	Viewfinder / External video output connector	99
7.2.3	HD - SDI (B) connector	99
7.2.4	HD - SDI (A) connector	99
7.2.5	Audio microphone 1 connector	100
7.2.6	Audio microphone 2 connector	100
7.2.7	Intercom headset connector	100
7.2.8	DC power input socket	101
7.2.9	DC power and tally output socket	101
7.2.10	Script light power supply socket	101
7.2.11	Teleprompter output / Reference input connector	102
7.2.12	Tracker communications connector	102
7.2.13	Auxiliary connector	103

Chapter 8 – Specifications

8.1	Specifications for LDK 8000	105
-----	--	------------

8.2	Specifications for LDK 5860 TriaxHD adapter	106
8.2.1	Dimensions	107

End-of-life product recycling

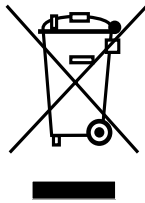

Grass Valley's innovation and excellence in product design also extends to the programs we've established to manage the recycling of our products. Grass Valley has developed a comprehensive end-of-life product take back program for recycle or disposal of end-of-life products. Our program meets the requirements of the European Union's WEEE Directive and in the United States from the Environmental Protection Agency, individual state or local agencies.

Grass Valley's end-of-life product take back program assures proper disposal by use of Best Available Technology. This program accepts any Grass Valley branded equipment. Upon request, a Certificate of Recycling or a Certificate of Destruction, depending on the ultimate disposition of the product, can be sent to the requester.

Grass Valley will be responsible for all costs associated with recycling and disposal, including freight, however you are responsible for the removal of the equipment from your facility and packing the equipment ready for pickup.

For further information on the Grass Valley product take back system please contact Grass Valley at + 800 80 80 20 20 or +33 1 48 25 20 20 from most other countries. In the US and Canada please call 800-547-8949 or 530-478-4148. Ask to be connected to the EH&S Department. In addition, information concerning the program can be found at:

www.thomsongrassvalley.com/environment

Important information

Read these instructions carefully and retain them for future reference.

During installation and operation of this equipment, local building safety and fire protection standards must be observed.

Before connecting the equipment to the power supply of the installation, verify the proper functioning of the protective earth lead.

Whenever it is likely that safe operation is impaired, the apparatus must be made inoperative and secured against any unintended operation. The appropriate servicing authority must then be informed. For example, safety is likely to be impaired if the apparatus fails to perform the intended function or shows visible damage.

Any changes or modifications not expressly approved in this manual could void your authority to operate this equipment.

Cautions and Warnings

Read and comply with the warning and caution notices that appear in the manual.

- Warnings indicate danger that requires correct procedures or practices to prevent death or injury to personnel.
- Cautions indicate procedures or practices that should be followed to prevent damage or destruction to equipment or property.

Warnings

To prevent fire or shock hazard, do not expose the unit to rain or moisture. If the unit is in a wet or damp environment, a rain cover must be used to protect it for personal safety reasons (EN60065). The rain cover supplied with the unit protects it according to safety specification EN60529 up to level IPX2 (spraying water).



To avoid electrical shock, do not remove covers or panels. Refer servicing to qualified personnel only.



In case of an emergency ensure that the power is disconnected.



Use only fuses of the type and rating specified.



Connect the product only to a power source with the specified voltage rating.



The Base Station must always be connected to protective earth. Do not interrupt the protection conductor inside or outside the unit. Do not disconnect the protective earth terminal. Intentional interruption is prohibited and is likely to make the unit dangerous.



To prevent risk of overheating, ventilate the units correctly.



For safety reasons the Base Station must be mounted in a 19-inch rack which has safety covers according to IEC65. When two Base Stations are mounted above each other, the minimum distance between them must be 50mm or the rack must be force-air cooled.

Triax cable systems

Only connect a Triax cable from the same LDK camera family to the unit.



Do not allow system earth currents to exceed 1.5A in the outer shield of the Triax cable or 0.2A in other cable shields.



To avoid excessive earth currents in a Triax system, galvanically separate the power earth connection of equipment connected to the camera from the camera earth.



It is strictly prohibited to short circuit the inner and outer shields of a Triax cable used to connect a camera to a base station.

Galvanic separation

Because of the nature of Triax systems, with long distances between camera and Base Station, the risk of earth currents flowing is greater. These earth currents can result in damage to the equipment.

For example, a monitor connected directly to the CVBS output of the camera is powered locally. The earthing point of the monitor's power supply can be at a different potential with respect to the earthing point of the Base Station. If the power earth of the monitor is also the video earth, then this earth potential is transferred to the camera via the shield of the BNC connector. The difference in earth potential between the camera and the Base Station results in an earth current in the Triax system.

To prevent earth currents from flowing in the Triax system, we recommend galvanic separation of earthed equipment connected to the camera. This separation can be achieved by using an isolation transformer between the local power outlet and the equipment connected to the camera. Alternatively, use equipment that has a double insulation and therefore does not require an earth connection.

Base Station earthing

The rear of the unit has two separate screw terminals for protective earth (PE) and video earth (VE). These are normally connected by a metal strap.

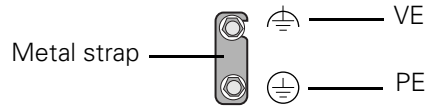

The protective earth terminal is internally connected to the protective earth conductor of the power cable. In normal circumstances the connection between the protective earth and the video earth should **not** be broken. If required, the central earth connection wire of the studio can be connected to terminal PE in accordance with VDE regulation 0800/part2.

Only if the studio (or OB van) is equipped with separate protective and video earth systems may the metal strap be removed. Under these circumstances the video earth terminal must be connected to the central functional earth potential (video earth) of the studio. This earth potential should have functional protective and noiseless earth (FPE) qualities as stated in the VDE regulation 0800/part2. A low impedance interconnection of both earth conductors must be provided at the central studio earthing point.

Precautions

To ensure continual high performance from the camera take the following precautions into consideration:

- Avoid very damp places. If the environment is wet or damp a rain cover must be used to protect the unit.
- Do not subject the unit to severe shocks or vibration.
- Do not expose the camera to extremes of temperature.
- Do not leave the unit in direct sunlight or close to heating appliances for extended periods.
- Do not allow sunlight to shine into the viewfinder.
- Do not allow LASER beams to shine into the lens as this could damage the CCD sensors.
- Avoid extreme highlights as these can cause various kinds of optical reflections.
- Be careful when connecting and disconnecting triax cables.
 - Do not mix triax units from different types of camera systems (HD with SD, RGB triax with digital triax).
 - Make connections swiftly and firmly to avoid false error messages.

Mains lead wiring for UK users

The wires in the mains lead are coloured in accordance with the following code:

GREEN and YELLOW- EARTH

BLUE- NEUTRAL

BROWN- LIVE

As the colours of the wires in the mains lead of this apparatus may not correspond with the coloured markings identifying the terminals in your plug proceed as follows:

- The wire coloured GREEN AND YELLOW must be connected to the terminal on the plug marked with the letter E or by the safety earth symbol  or coloured GREEN or GREEN AND YELLOW.
- The wire coloured BROWN must be connected to the terminal marked with the letter L or coloured RED.
- The wire coloured BLUE must be connected to the terminal marked with the letter N or coloured BLACK.

Ensure that your equipment is connected correctly - if you are in any doubt consult a qualified electrician.

Chapter 1

Introduction

1.1 Technology

The LDK 8000 is a high definition multi-standard, multi-format digital camera head using three 2/3-inch HD-DPM⁺™ sensors. The camera head can be combined with the TriaxHD adapter for a flexible camera that is equally at home in the studio or out on location.

The SportCam version can capture true progressive HD images, natively, in multiple formats and frame rates. It supports 2x high-speed acquisition at either 100 Hz or 119.88 Hz.

1.1.1 HD sensors

The camera head uses HD-DPM⁺™ CCD sensors which offer superior performance and ultimate flexibility. Native wide screen pictures in the high-definition formats 1080i, 1080p (WorldCam) and 720p are produced at the touch of a button. This unique native multi-format capability is realized with innovative 9.2 million pixel 2/3" CCD sensors. These allow vertically grouping of different numbers of pixels on the sensors themselves. There is no need for HDTV format conversion during digital signal processing which would lead to quality degradation.

These sensors have a high dynamic range and high linear sensitivity across all camera lens apertures. They are based on Frame Transfer technology, which ensures that there is neither lag nor smear.

1.1.2 Digital processing

The advanced digital processing of the camera is based on 14-bit A/D converters and more than 22-bit internal processing. All major camera functions are processed in the digital domain, including knee, gamma, detail, matrix and colour correction.

The intelligent continuous automatics facility provides automatic control of black levels and black shading. Each sensor provides black reference signals that are used to monitor temperature changes. This means that continuous automatic correction is applied without operator intervention.

The digital detail processing uses full amplitude video RGB signals via an extended dynamic range detail circuit. Colorimetry is selected by means of a variable 6-point digital matrix or via preset matrices. Digital gamma circuits provide a wide range of standardised gamma curves and enable soft contrast in black scenes to be enhanced, together with hard contrast and saturated colour in bright scenes. The matrix and gamma sequence is software programmable for precise colour matching.

1.1.3 Film-like characteristics

The pivoting knee circuit adapts both the knee point and the compression ratio according to the highlight content of the picture to emulate the softly limiting S-shaped transfer characteristics of film. Digital True Colour Knee circuitry maintains the correct hue for compressed highlights, reproducing colours faithfully, even overexposed skin tones.

Digital contrast circuitry provides a black stretch function for more detail in black areas and a black press function for improving the contrast impression by simulating the S-curve of film.

1.1.4 Focus assist

With HDTV, focusing is even more critical than before. The LDK 8000 has special patented focusing aids. A unique viewfinder zoom function enlarges the viewfinder image instantly with a simple press-button action, thus providing improved means for focusing. A patented crawler circuitry adds motion in the viewfinder to objects in sharp focus.

1.1.5 Standard version

The Standard version supports 1080i/720p HD formats in 50, and 59.94 Hz, and simultaneously provides high-quality SDTV outputs in either 50 Hz or 59.94 Hz.

The following acquisition formats are available for the Standard version:

- 1080i at 59.94 Hz
- 1080i at 50 Hz
- 720p at 59.94 Hz
- 720p at 50Hz

1.1.6 SportCam version

The SportCam version provides, in addition to the Standard version formats, high-speed acquisition formats that are output as a two-phase signal from the high-speed base station.

The following acquisition formats are available for the SportCam version:

- 1080i at 59.94 Hz
- 1080i at 119.88 Hz
- 1080i at 50 Hz
- 1080i at 100 Hz
- 720p at 59.94 Hz
- 720p at 119.88 Hz
- 720p at 59.94 Hz
- 720p at 100Hz

1.1.7 WorldCam version

The WorldCam version provides, in addition to the Standard version formats, digital cinematography formats in 1080p and 720p, which give an impression of motion comparable to film cameras running at identical speeds.

The WorldCam also provides convenient built-in frame-rate conversions for easy connection to existing HD peripherals, offering possibilities for cost-effective monitoring and recording combined with the motion portrayal of film cameras. The 1080p format at 23.98 Hz, for example, can be converted using 3:2 pull-down to 1080i at 59.94 Hz right inside the camera.

The following acquisition formats are available for the WorldCam version:

- 1080i at 59.94 Hz
- 1080i at 50 Hz
- 1080p at 23.98 Hz
- 1080p at 24 Hz
- 1080p at 25 Hz
- 1080p at 29.97 Hz
- 720p at 59.94 Hz
- 720p at 50 Hz
- 720p at 23.98 Hz
- 720p at 25 Hz
- 720p at 29.97 Hz

1.1.8 Advanced TriaxHD features

TriaxHD, which is a further development of the Emmy Award winning triax transmission system, makes the camera compatible with industry standard triax cables. This allows the reuse of existing, reliable and valuable cable inventories.

TriaxHD allows video transmission and remote control of cameras up to a distance of 1,200 m (4,000 ft.) and beyond, using industry standard 14 mm triax cables. It is based on 30MHz full-bandwidth 4:2:2 transmission (Y/Cr/Cb components).

The double side band modulation technique used in combination with Y/Cr/Cb transmission ensures linearity, resolution and an optimal signal-to-noise ratio over the maximum cable length. Bandwidth efficient channel combining and equalization techniques minimize cross-talk and interference. Teleprompter and viewfinder signals maintain high performance with relatively long cable lengths.

The communication facilities provide for two-wire or four-wire high quality intercom signals. Full camera control is provided via a C2IP Ethernet-based control network.

The TriaxHD adapter is equipped with a rotary triax connector which provides freedom of movement during portable use of the camera and protects the connector from being damaged in near-floor conditions.

TriaxHD Base Station

The TriaxHD Base Station, as well as providing high definition outputs, optionally offers simultaneous high-end SDTV outputs. This facilitates a gradual and managed transition from SDTV to HDTV.

TriaxHD high-speed Base Station

The SportCam when used together with TriaxHD high-speed Base Station provides a digital dual-phase high-speed output. This 2x SDI connection can be supplied to an external disk recorder to obtain exceptional slow motion playback performance.

1.1.9 SuperXPander

The optional available SuperXpander together with the 7-inch HD high resolution viewfinder turns the portable Triax camera into a full-featured studio camera for studio and EFP situations.

1.2 Features

- Ultimate flexibility with HD-DPM+™ CCD sensors, offering native switchability between the interlaced 1080i and true progressive 1080p high definition digital cinematography formats.
- The CCDs have 9.2 million pixels, with 1920 (H) x 4320 (V) effective picture elements.
- Frame Transfer technology ensures no smear.
- 14-bit A-to-D and more than 22-bit digital processing with unique software programmable video path.
- Superior all digital highlight handling with a wide dynamic range.
- Unique circuitry for pivoting knee and True Colour Knee.
- Variable gain control and variable colour temperature.
- Wide range of presets and variable 6-point digital matrix assure accurate colour matching.
- Fluorescent light matrix.
- Digital gamma with unique standard preset values and highest accuracy.
- Digital detail with an extensive range of parameters.
- Advanced detail correction includes two automatic skin settings.
- Intelligent Continuous Automatics black levels, black shading and video levels - no set-up time required.
- Digital contrast with standard black stretch and black press.
- International standard 2/3-inch lens interface.
- Optical servo-controlled four-position neutral density filter wheel.
- Optical servo-controlled effect filter wheel with soft focus, four-point star and six-point star filters.

- Electronic colour filter can be used for creating a special look (warm/cold) of a scene, or for a smooth colour temperature control around the white balance setting.
- Smart card for personal settings and security.
- Owner card for setting user levels, and for copying and storing control settings.
- Protected, easy-to-operate controls and switches with read-out of all settings.
- Viewfinder status read-out of primary camera functions.
- Clean scan feature allows capture of computer and other monitor pictures.

1.3 Accessories

Xpander	LDK 4489
SuperXpander	LDK 4488
7" viewfinder support	LDK 6517
HD/HS Triax Repeater	LDK 4800
2" viewfinder HDTV	LDK 5302/60
5" viewfinder HDTV	LDK 5305/01
7" viewfinder HDTV	LDK 4021
Wide Angle adapter for 2" viewfinder	LDK 5390/00
Left eye adapter for 2" viewfinder	LDK 5390/10
Sunhood for 5" viewfinder	LDK 6992/02
Raincover for camera with 5" viewfinder	LDK 5021/05
Tripod plate	LDK 5031/10
Headset dynamic XLR-5 double muff	LDK 8111/37
Headset dynamic XLR-5 single muff	LDK 8111/51
Scriptboard with light	LDK 6985/21
Transport/flightcase	LDK 5020/00
Carrying bag	LDK 5020/01
AC power supply 100 W	LDK 5901/00

Chapter 2

Installation

2.1 Packing/unpacking

Inspect the shipping container for evidence of damage immediately after receipt. If the shipping container or cushioning material is damaged, it should be kept until the contents of the shipment have been checked for completeness and the units have been checked mechanically and electrically.

The shipping container should be placed upright and opened from the top. Remove the cushioning material and lift out the contents. The contents of the shipment should be checked against the packing list. If the contents are incomplete, if there is mechanical damage or defect, or if the units do not perform correctly when unpacked, notify your Grass Valley Nederland B.V. sales or service centre within eight days. If the shipping container shows signs of damage or stress, notify the carrier as well.

If a unit is being returned to Grass Valley Nederland B.V. for servicing, try to use the containers and materials of the original packaging. Attach a tag indicating the type of service required, return address, model number, full serial number and the return number which will be supplied by your Grass Valley Nederland B.V. service centre.

If the original packing can no longer be used, the following general instructions should be used for repacking with commercially available materials:

1. Wrap unit in heavy paper or plastic.
2. Use strong shipping container.
3. Use a layer of shock-absorbing material around all sides of the unit to provide firm cushioning and prevent movement inside container.
4. Seal shipping container securely.
5. Mark shipping container FRAGILE to ensure careful handling.

2.2 Transport case

It is important to protect your camera against damage when transporting it. To do this, a transport case (LDK 5020/00) is optionally available for the camera, lens, viewfinder and some accessories.

Figure 2-1. Transport case

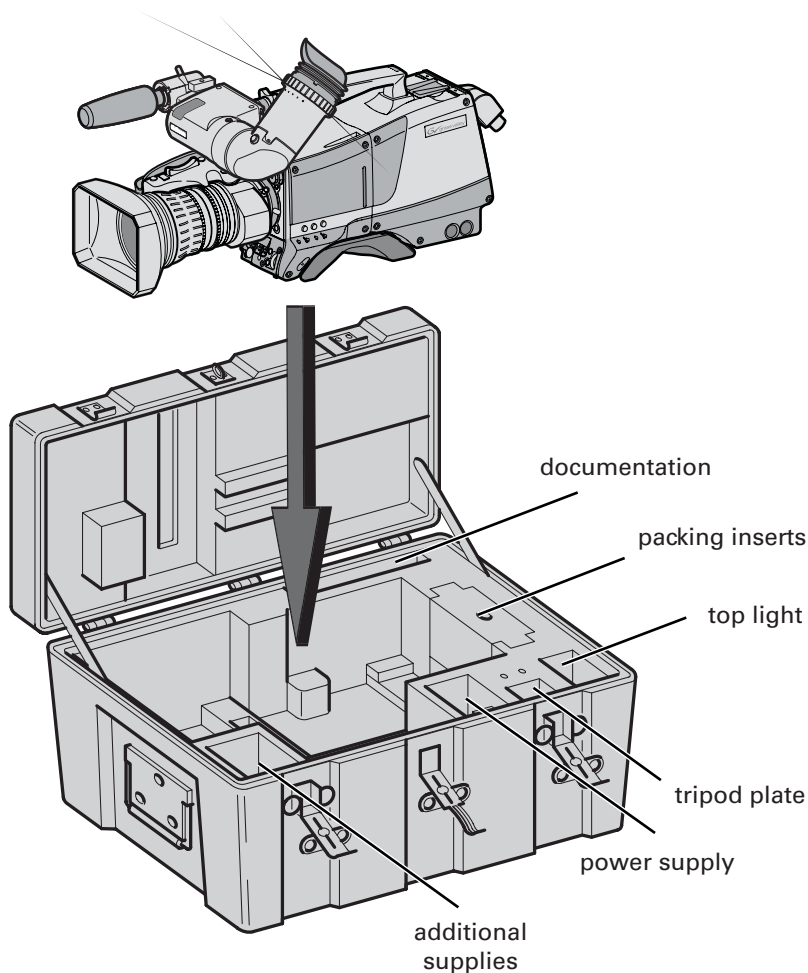

The camera is packed in the transport case as shown in the figure above. This ensures that the camera is not damaged during transport. Turn the 2-inch viewfinder downwards so that it does not protrude above the top of the camera. Several foam packing inserts are provided to enable different configurations of the camera to be packed securely. These inserts are used to support the rear of the camera. Make sure you use the correct foam insert for your particular configuration.

2.3 Mounting a lens

To attach a lens to the camera head proceed as follows:

1. Ensure that the lens locking ring (1) is in the unlocked position - turned counterclockwise.
2. Remove the dust protection cap (2).
3. Slot the lens into the lens mount (3).
4. Turn the lens locking ring (1) clockwise to lock the lens in place.
5. Connect the lens cable to the lens connector (4) at the right side of the camera.
6. Place the lens cable into the bottom clip at the front of the camera and clip (5) located at the side.

Figure 2-2. Lens mounting

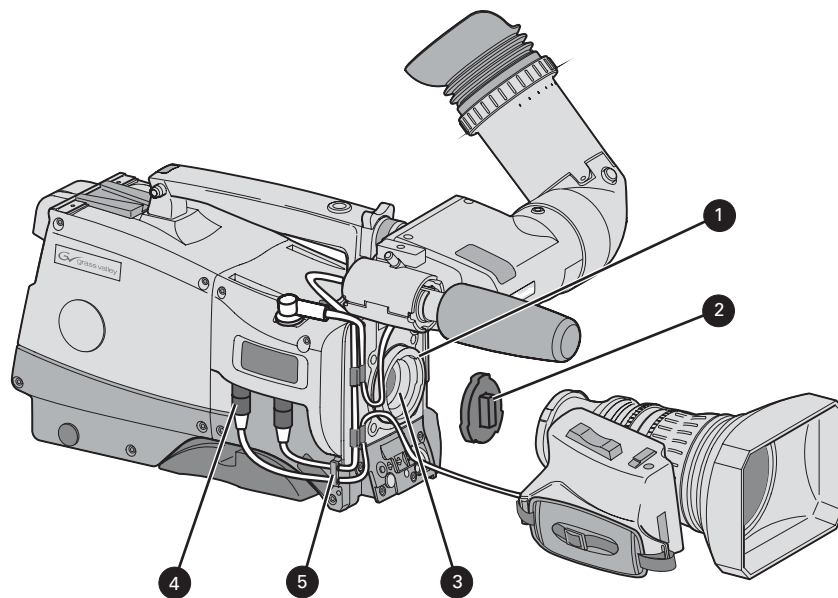

Caution

Do not attach a lens weighing more than 5 kg to the camera without a support.

When a new lens is fitted to the camera it may be necessary to carry out some adjustments to optimize its use, for example, back focus or shading. For more information about these adjustments refer to the lens manufacturer's documentation.



Note

Always mount the dust protection cap when the lens is not connected to the camera.

2.4 2-inch viewfinder

2.4.1 Mounting viewfinder and microphone holder

To mount the viewfinder LDK 5302/60 proceed as follows:

1. Loosen locking ring (1) of viewfinder support bracket (2) at the front of the camera handle. (As seen from the rear of the camera, turning the locking ring counterclockwise moves it towards the handle.)
2. Slide the viewfinder onto the viewfinder support bracket.
3. Tighten the locking ring (1) by turning it clockwise (as seen from rear) so that the viewfinder is mounted securely to the support.
4. Connect the viewfinder cable to the viewfinder connector socket (6) at the top right of the camera.
5. Slide the microphone holder (4) onto the viewfinder and secure with the knurled screw (5).



Caution

Always fit the microphone holder as it functions as a safety stop for the viewfinder.

6. To improve the comfort of the skin contact when using the viewfinder, fit the eye piece cover (3) to the rubber eyepiece. Spare eye piece covers (ordering number 3922 405 00461) are available at your Grass Valley representative.

Figure 2-3. Viewfinder mounting

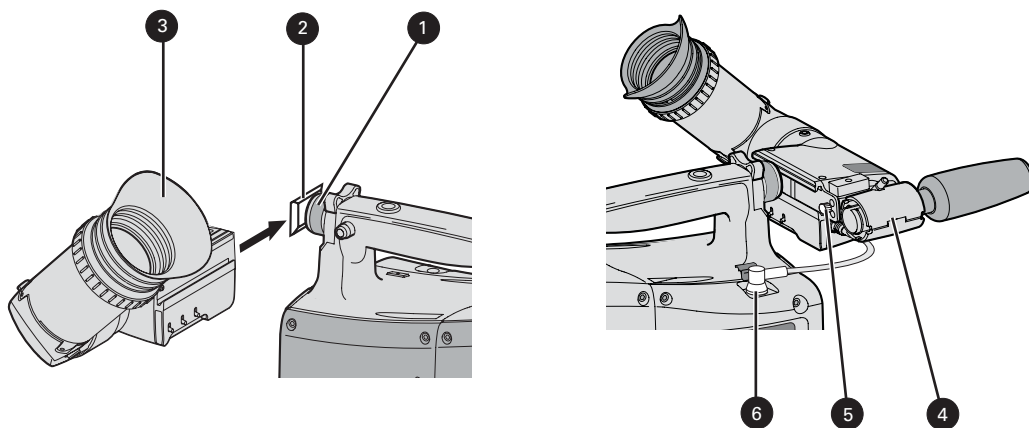

2.4.2 Positioning the viewfinder

The horizontal position of the viewfinder can be adjusted as follows to suit your requirements:

1. Loosen the locking ring (1). (As seen from the rear of the camera, turning the locking ring counterclockwise moves it towards the handle.)
2. Slide the viewfinder horizontally along the rail to the desired position.
3. Tighten the locking ring (1) by turning clockwise.

The dioptre hood and eyepiece of the viewfinder can be rotated vertically.

The viewfinder can be positioned backwards and forwards along the camera axis. Loosen the support bracket round bar retaining lever (2) and slide the round bar (3) forwards or backwards. When the desired position is reached tighten the support bracket round bar retaining lever (2) again.

To use the viewfinder at a distance press the button (4) below or above the eyepiece tube and swing it free of the associated clip (5). The display can now be seen from further away.

Figure 2-4. Viewfinder positioning

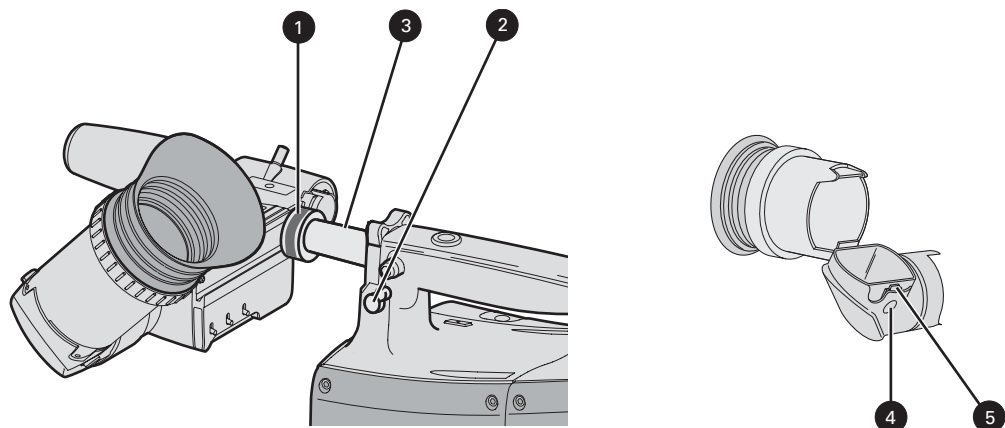

2.5 Viewfinder accessories

2.5.1 Wide angle eyepiece

If you regularly use the viewfinder at a distance, for example, when you use the camera in the hand-held position, it is recommended that you fit the optionally available wide angle eyepiece (LDK 5390/00). To fit the wide angle eyepiece proceed as follows:

1. Hold the eyepiece (1) securely.
2. Press the button (2) below the eyepiece tube and swing it free of the button clip (3).
3. Press the button (4) above the eyepiece tube and remove the eyepiece.
4. Fit the wide angle eyepiece (1) to the two clips (3) ensuring that they both click into place.

Figure 2-5. Viewfinder wide angle eyepiece

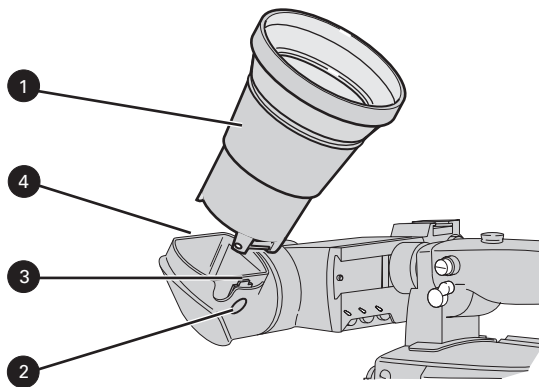

2.5.2 Left eye adapter

A left eye adapter is optionally available (LDK 5390/10) to allow the viewfinder to be used with the left eye. Before mounting the viewfinder onto the camera, attach the left eye adapter (1) to the viewfinder and secure it using the screw (2). Do not forget to mount the microphone support bracket (3) at the end of the left eye adapter.

Figure 2-6. Viewfinder left eye adapter

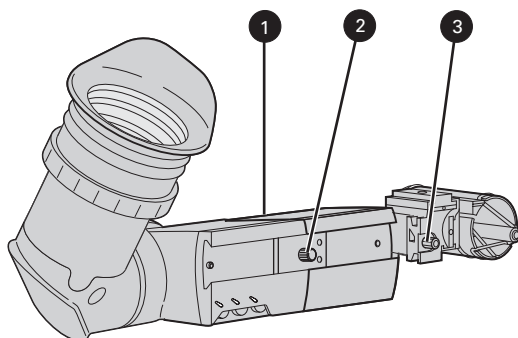

2.6 Mounting a microphone

To attach the optional microphone (AJ-MC700) to the camera proceed as follows:

1. Open the microphone holder by unscrewing the knurled screw (2) of the microphone support bracket (1) on the viewfinder and open.
2. Slide the microphone into the split tube until the microphone shoulder reaches the mark (5) in the tube.
3. Place the tube with the microphone into the holder with the split facing upwards. Mount the microphone as straight as possible.
4. Ensure that the rubber supports at the back and front of the holder fit into the rims (6) around the tube.
5. Close the holder and tighten the knurled screw at the top. Don't allow the wind hood to touch the holder (7) as this reduces the damping effect.
6. Connect the microphone cable to the **MIC** audio connector (3) on the right side of the camera. To avoid mechanical pick-up, do not let the microphone cable touch the holder.
7. Place the microphone cable into the top clip at the front of the camera and into clip (4) at the side of the camera. (Pull and twist clip to open it.)

Other microphones with a diameter of 21mm can also be used, however, ensure that the sensitivity of the input that match that type of microphone are correctly selected in the camera **INSTALL** menu. When a longer microphone is used, it is not necessary to place it in the split tube. Phantom power is always present on the front microphone socket.

Figure 2-7. Microphone mounting

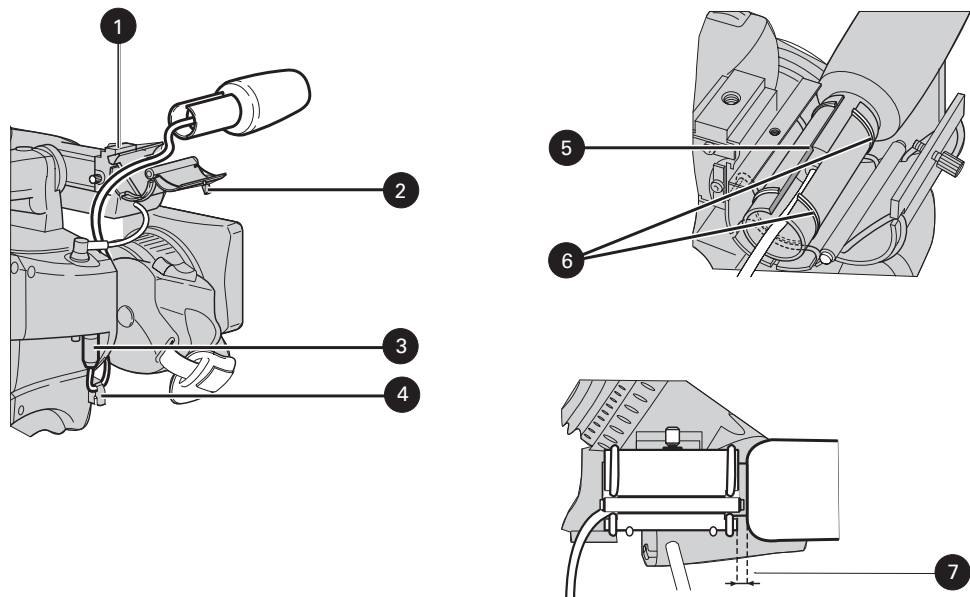

2.7 Tripod adapter plate

To mount the camera on a tripod, the tripod plate LDK 5031/10 must first be attached to the tripod. Follow the tripod manufacturer's instructions to mount the wedge plate supplied with the tripod and the tripod adapter plate firmly onto the tripod. Attach the camera to the tripod adapter plate as follows:

1. Slide the camera horizontally along the tripod adapter plate from back to front ensuring that the front of the camera engages the V-slot (1) at the front of the tripod adapter plate, and that the slot on the bottom of the camera engages the stud (2) at the rear of the tripod adapter plate.
2. Firmly push the camera forward until it clicks into place.
3. When the camera is mounted firmly, the locking lever (5) swings around fully to the rear of the plate. If the lever does not travel the full distance, you should manually lock it into place.



Caution

Failure to attach the camera to the tripod adapter plate in the correct manner could result in an unsecured camera. Ensure that the rear stud (2) is engaged and that the camera clicks into place.

Figure 2-8. Tripod adapter plate

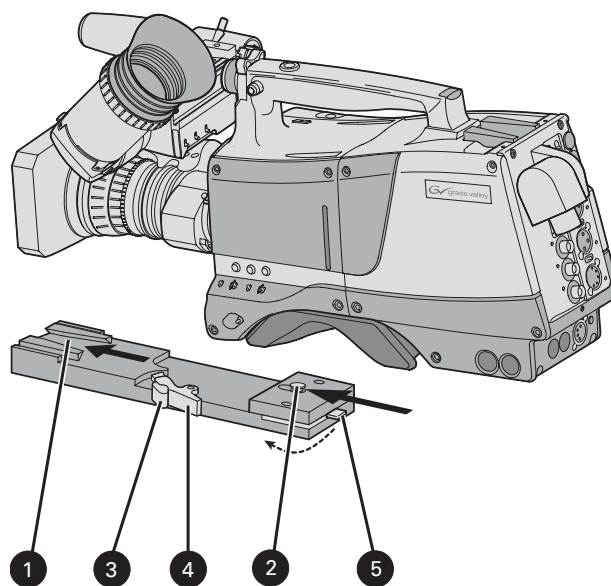

Remove the camera from the tripod as follows:

1. Open the locking lever (5) to free the rear stud (2).
2. Press and hold the red locking lever (3) against the release handle (4).
3. Ensure that you have a firm hold of the camera.
4. Pull the release handle (4) forward.
5. Move the camera backwards and up.

2.8 Adjusting the shoulder pad

To change the position the shoulder pad press and hold lever (1). The shoulder pad can now be moved backwards and forwards along the axis of the camera. Adjust the shoulder pad when all units have been mounted to get the best balanced shoulder position.

Figure 2-9. Shoulder pad

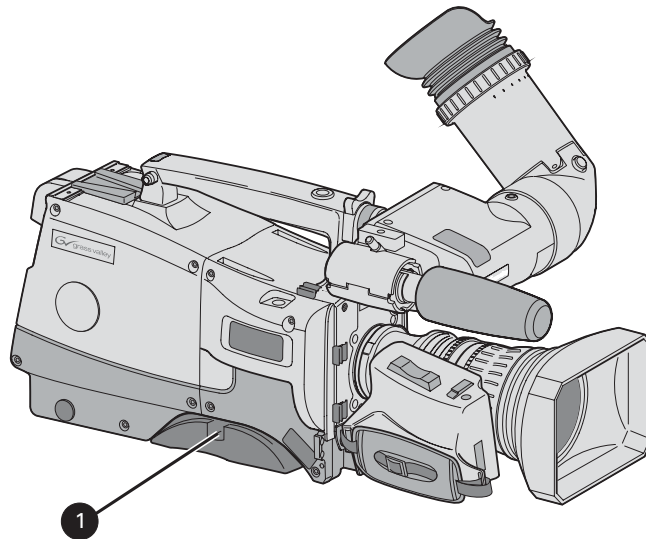

2.9 Attaching an adapter

The camera head is a multi-role camera head that can be used with various adapters.



Caution

Be extremely careful with the connectors between the camera head and the adapter. Do not allow the guide pins to damage the pins of the connector. Follow these steps in the order given. Tightening or loosening the screws in the wrong order could result in mechanical damage to the camera.

To attach an adapter to the camera proceed as follow:

1. Fit the guide pin at the top rear of the camera head and the guide pins on either side of the camera connector into the corresponding slots (1 and 2) of the adapter.
2. First, tighten the two horizontal screws (3) on the top of camera.
3. Next, tighten the two horizontal screws (4) at the front of the camera.
4. Lastly, tighten the vertical screw (5) in the handle of the camera.

To detach an adapter from the camera head follow the steps for attaching it in the reverse order.

Figure 2-10. Attaching an adapter

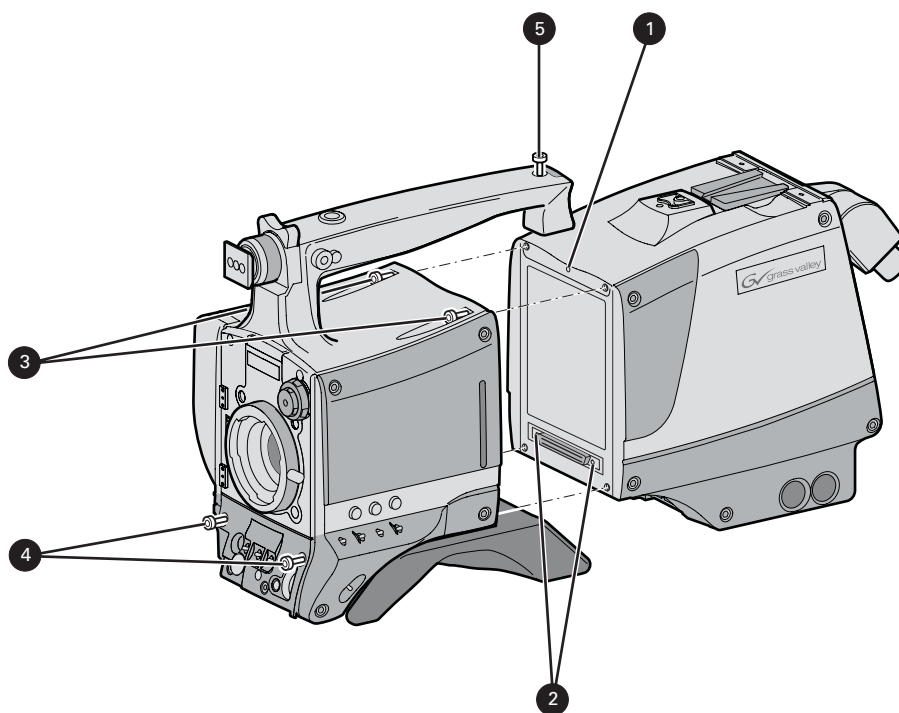

Chapter 3

Configurations

3.1 TriaxHD mode

A camera head with the LDK 5860 TriaxHD adapter is connected to a TriaxHD Base Station using a Triax cable. The maximum length of cable that can be used without significant degradation of the video signal is 1,200 m (4,000 ft.) for a 14 mm Triax cable.

The power supply is applied to the Base Station and via the Triax cable to the camera. An OCP 400 operational control panel can be connected directly to the Base Station using a cross-over Ethernet cable.

Figure 3-1. Camera in TriaxHD mode

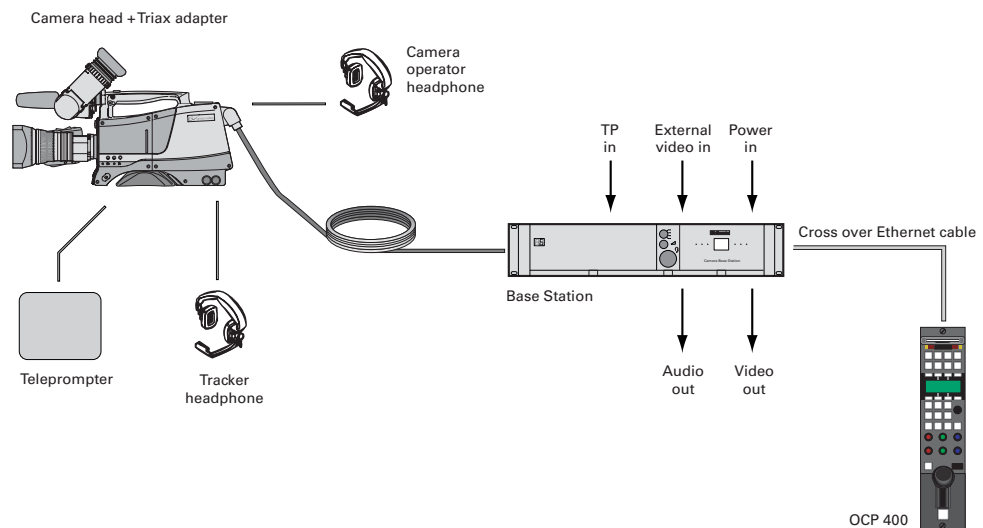

3.2 Multiple TriaxHD cameras with C2IP network

The Base Stations are each connected to a network hub or router via an Ethernet cable (straight through, not cross-over). The OCP 400 operational control panels and, if required the MCP 400 Master Control Panel, are also connected to the Ethernet network via a hub or router.

Figure 3-2. Multiple HD cameras with C2IP network control

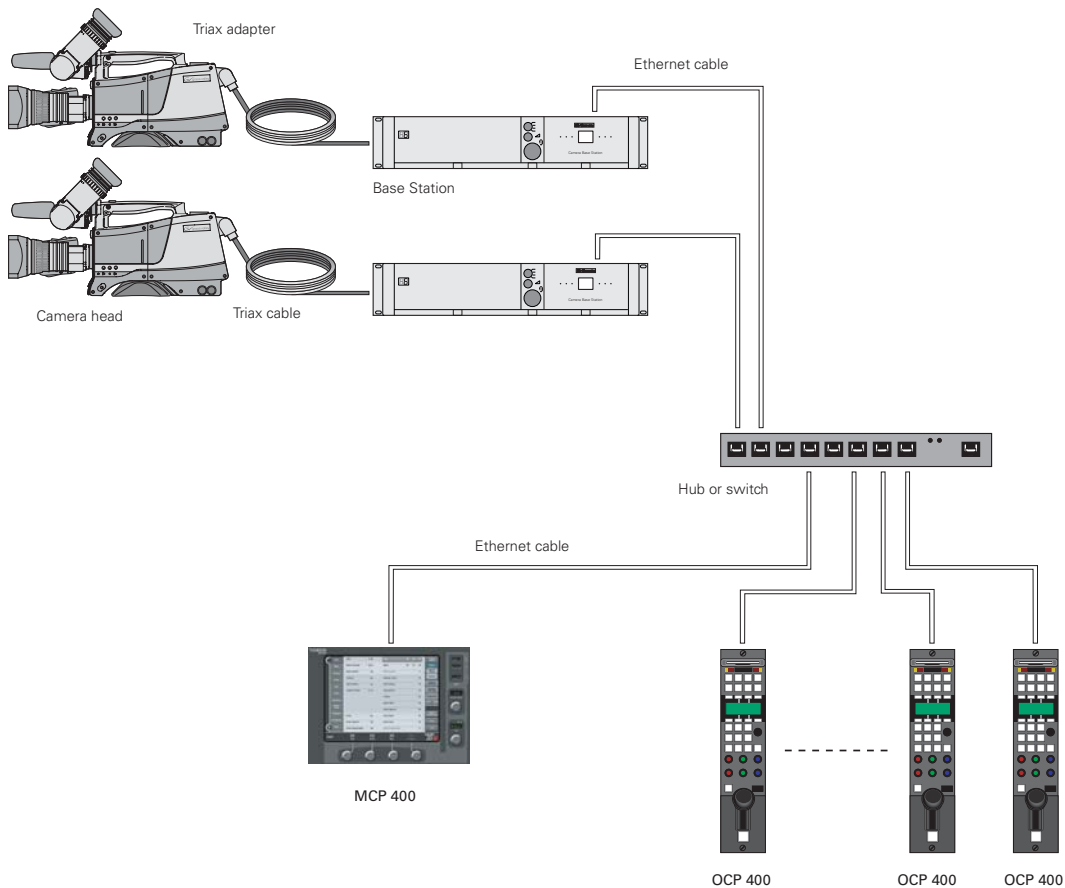

3.3 Camera with TriaxHD adapter and SuperXpander

A camera head with the LDK 5860 TriaxHD adapter can be mounted in the LDK 4488 SuperXpander (or in the LDK 4489 Xpander). This enables large box lenses to be used with the camera. The LDK 4021 7-inch HDTV viewfinder can be mounted on the SuperXpander.

The camera with the TriaxHD adapter connects to the SuperXpander via a flying lead. The power supply for the camera is supplied via this lead. The SuperXpander is connected to a TriaxHD Base Station using a Triax cable. This configuration can be powered either:

- from the Base Station via the Triax cable, or
- locally with the mains power supply connected directly to the SuperXpander.

The maximum length of triax cable that can be used without significant degradation of the video signal is 1,200 m (4,000 ft.) for a 14 mm Triax cable when the configuration is powered locally.

To control the configuration an OCP 400 operational control panel can be connected directly to the Base Station using a cross-over Ethernet cable. The Base Station is powered by a mains power supply.

Figure 3-3. Camera with SuperXpander and TriaxHD adapter

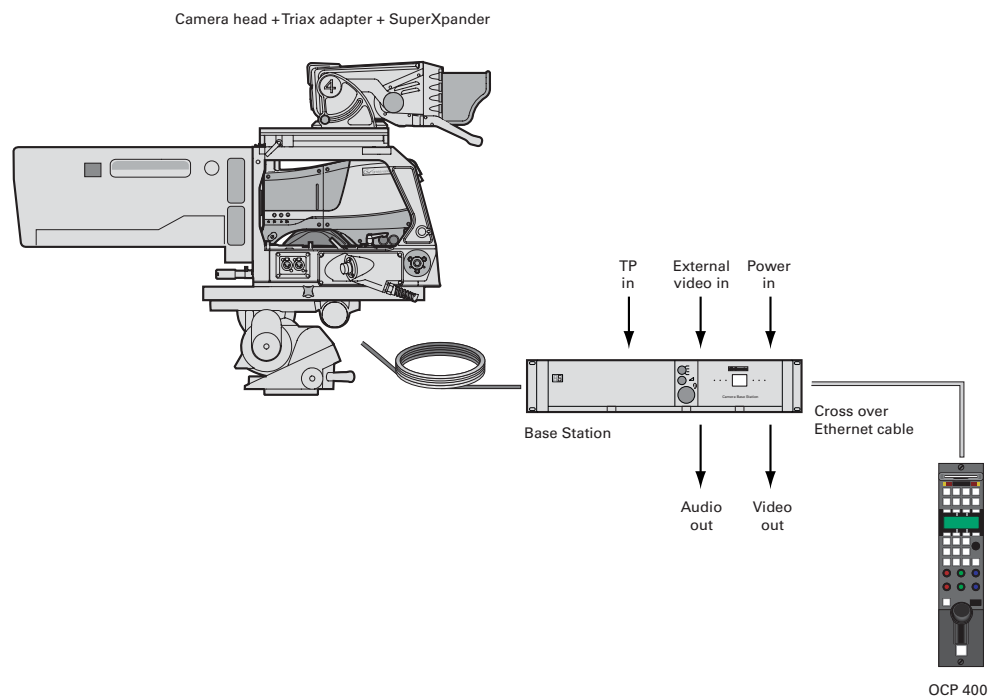

3.4 SportCam with high-speed Base Station

To obtain a high-speed output, the SportCam must be connected to the high-speed TriaxHD Base Station (LDK 4506). The connection between the SportCam and the Base Station uses the same Triax cable as the other configurations and operational control uses the same C2IP network and units. The high-speed TriaxHD Base Station supplies a dual-phase high-speed HD signal for a recording system.

Figure 3-4. SportCam with SuperXpander and high-speed TriaxHD Base Station.

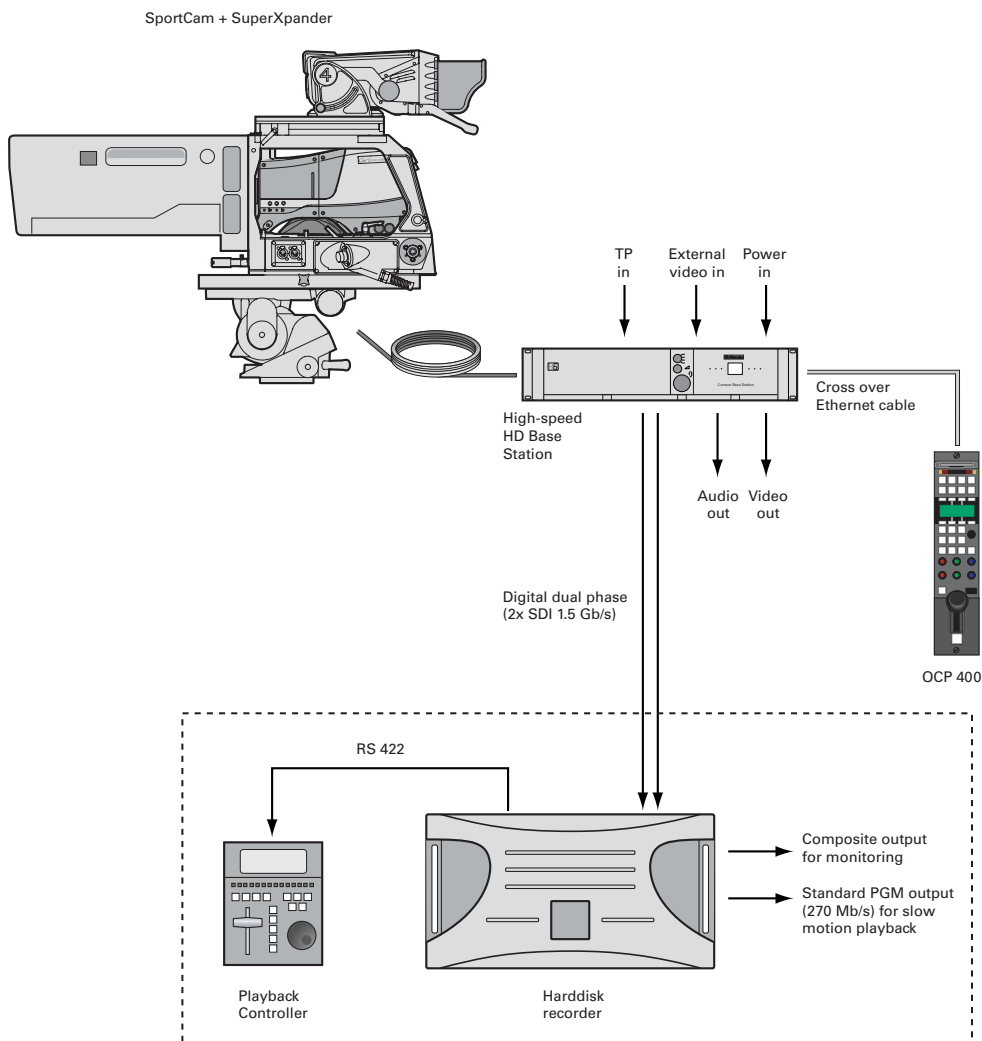

3.5 Local mode

A camera head with the LDK 5860 TriaxHD adapter can be used in the local mode. The DC power supply is applied to the adapter. An OCP 400 operational control panel can be connected directly to the camera using the RS232 connection. A reference signal can be applied to genlock the camera.

Standard and WorldCam versions

The HD SDI (B) / VF connector at the rear carries the HD SDI viewfinder signal. The HD SDI (A) connector carries the HD SDI camera signal.

SportCam version

The HD SDI (A) and HD SDI (B) / VF connectors at the rear carry the HD SDI viewfinder signal. An HD SDI camera signal output is not available.

Figure 3-5. Camera in local mode

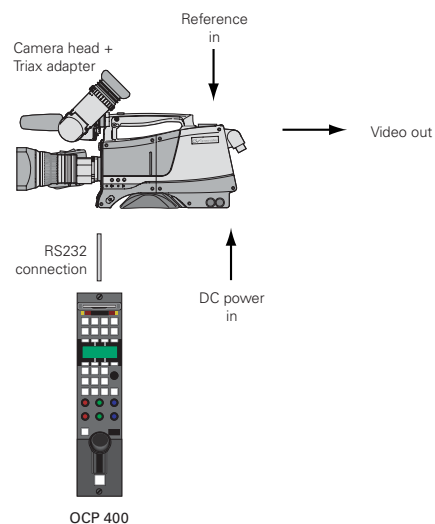

3.6 Triax cable lengths

The approximate maximum cable lengths between a Base Station and a camera are given in the table below. The signal degrades gradually when these lengths are exceeded. Reduce these lengths by 20% when a teleprompter signal is sent to the camera.

The maximum length is given for cables of the highest quality. The quality of some cables and the interconnections can adversely affect this maximum length.

Cable diameter	Maximum length
8 mm (0.33 inch)	500 m (1,600 ft)
11 mm (0.43 inch)	700 m (2,300 ft)
14 mm (0.55 inch)	1,200 m (4,000 ft)



Note

The maximum cable length for 8 mm Triax is adversely influenced by the power consumption of the camera.

Chapter 4

Location of controls

4.1 Camera head controls and connectors

Figure 4-1. Camera connector location

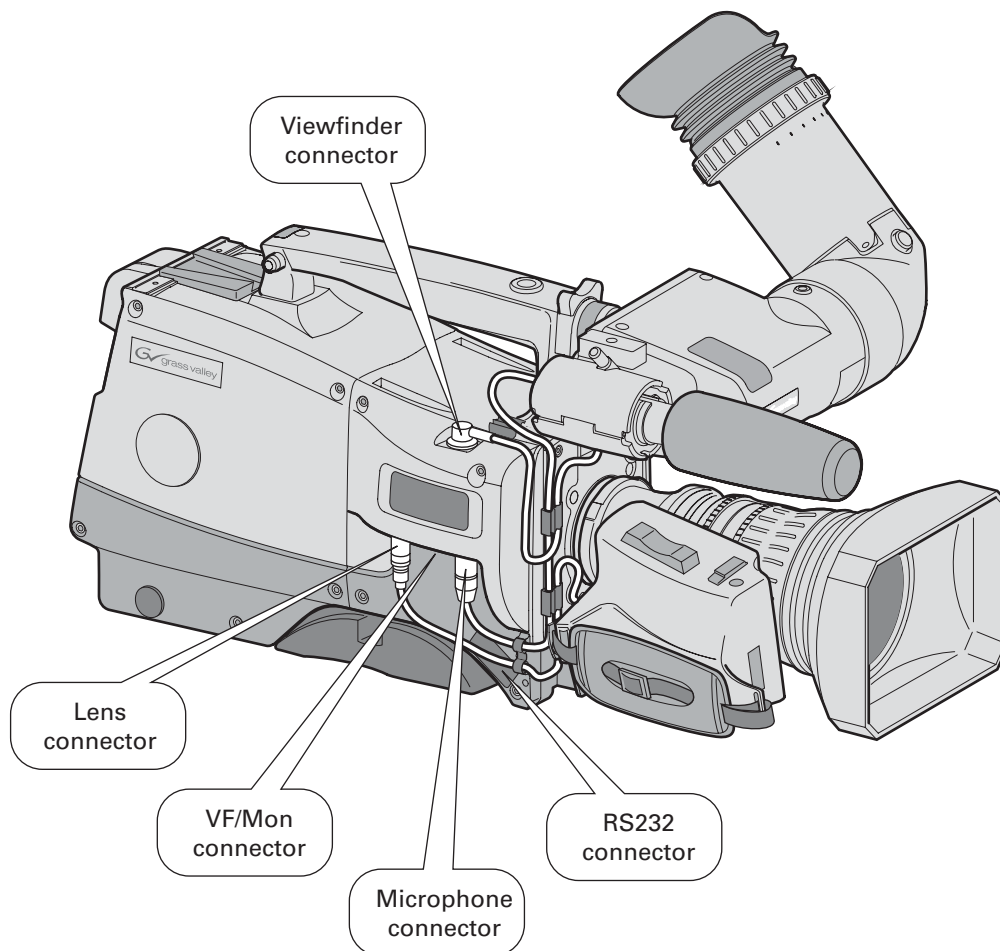

Figure 4-2. Camera head controls - front-left

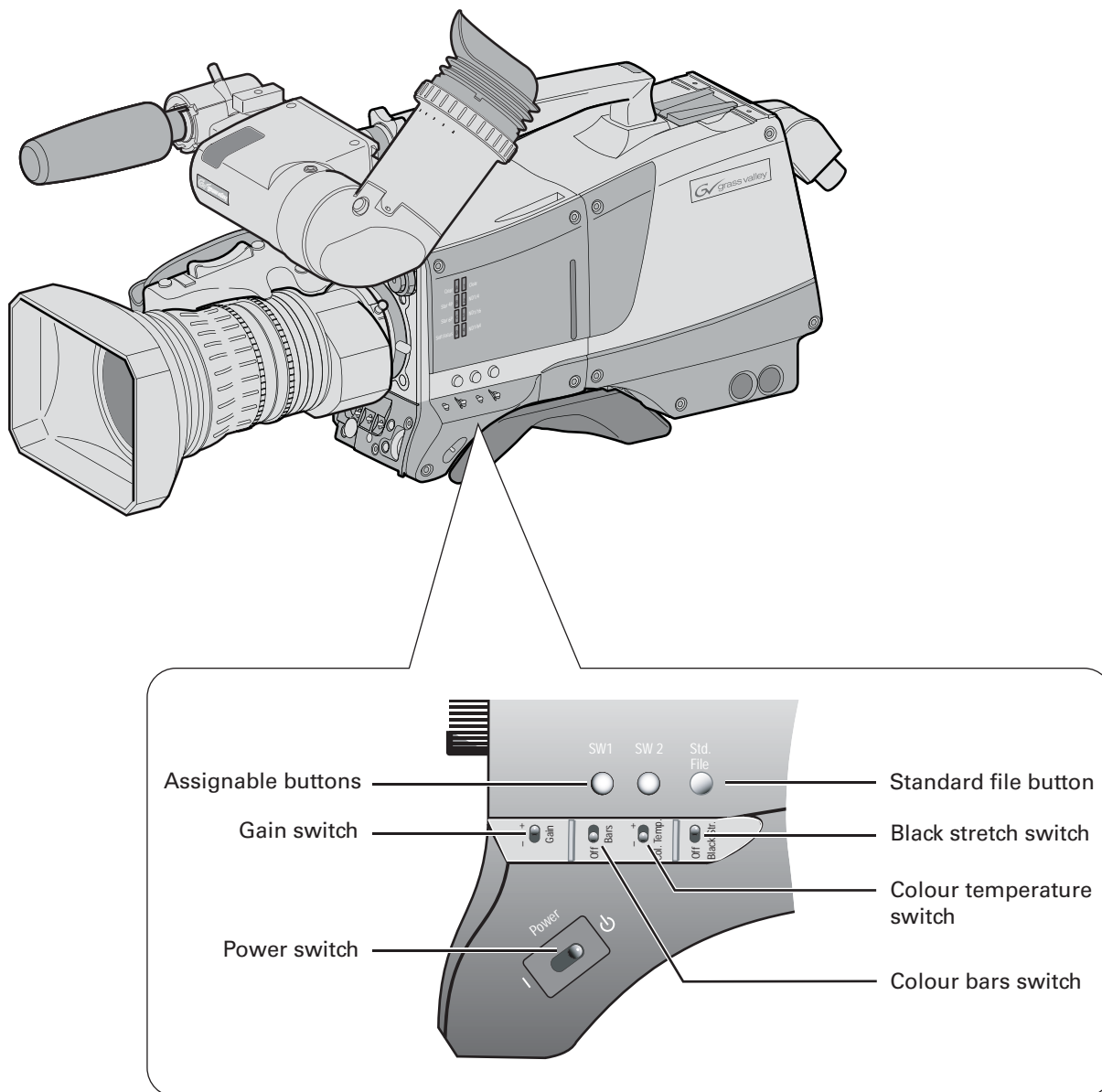
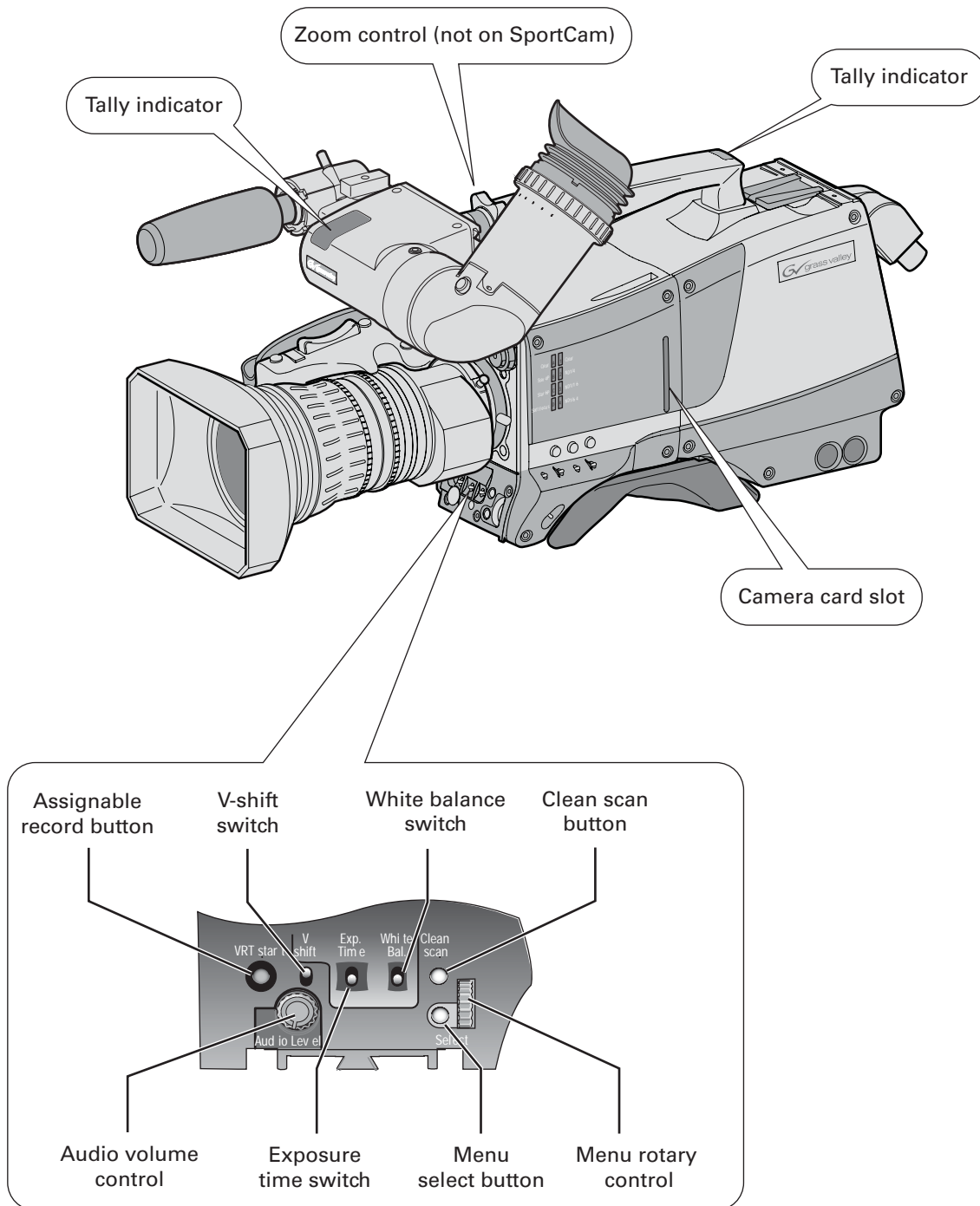

Figure 4-3. Camera head controls



4.2 TriaxHD adapter controls and connectors

Figure 4-4. TriaxHD adapter controls

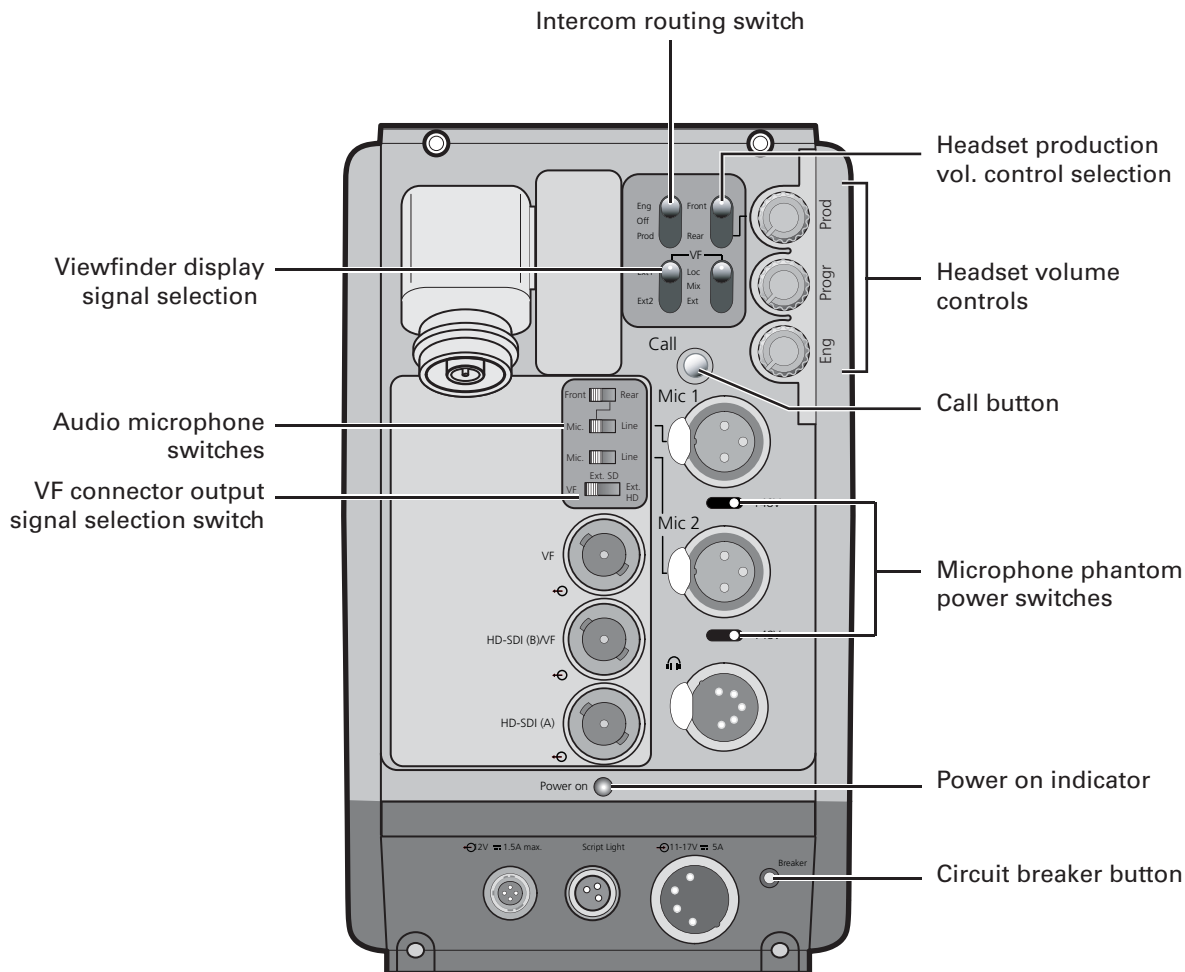
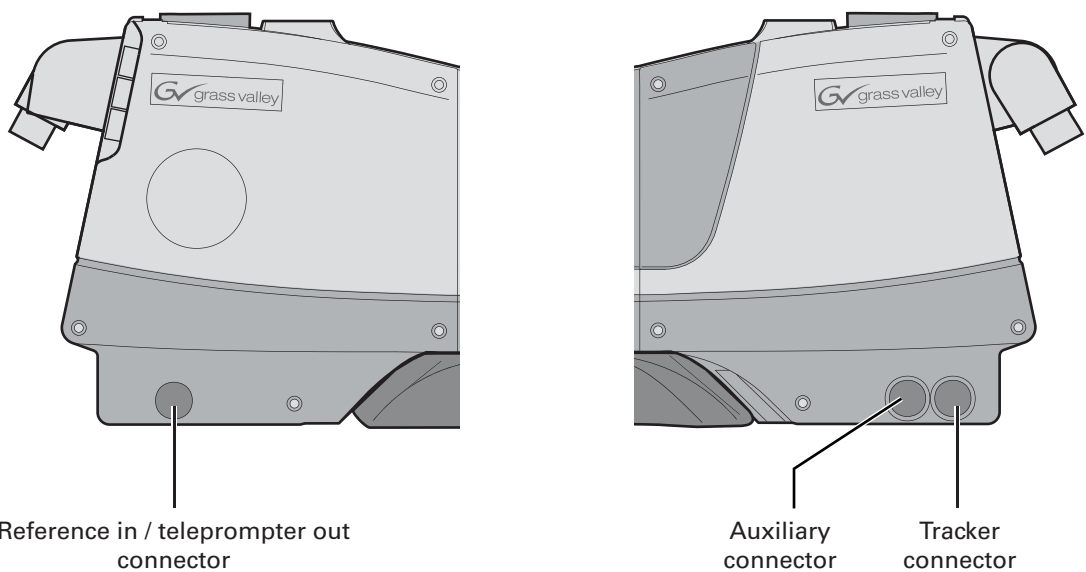
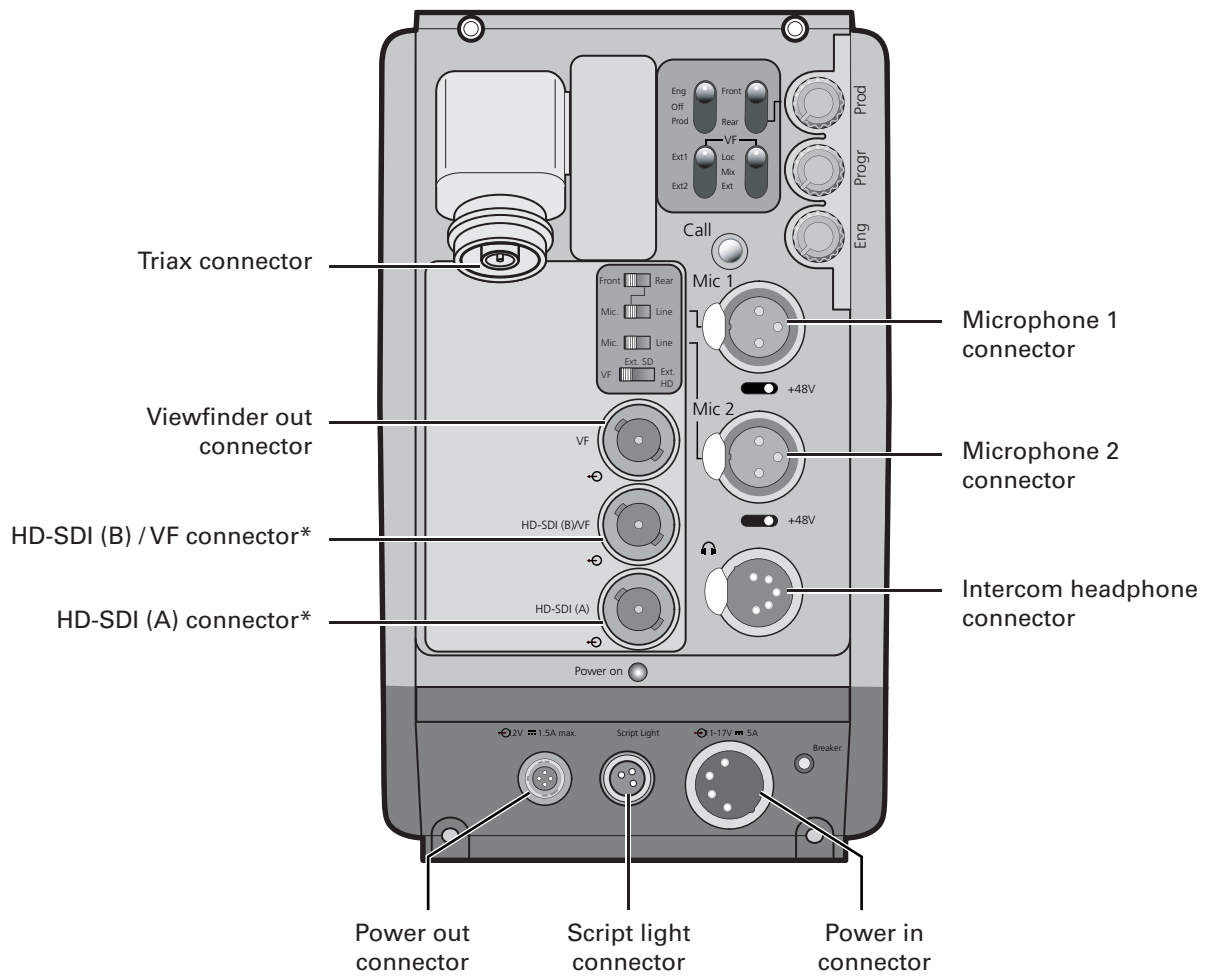

Figure 4-5. TriaxHD adapter connector location



* These connectors only carry the VF SDI signal in the SportCam version.

4.3 Viewfinder controls and indicators

Figure 4-1. Viewfinder controls

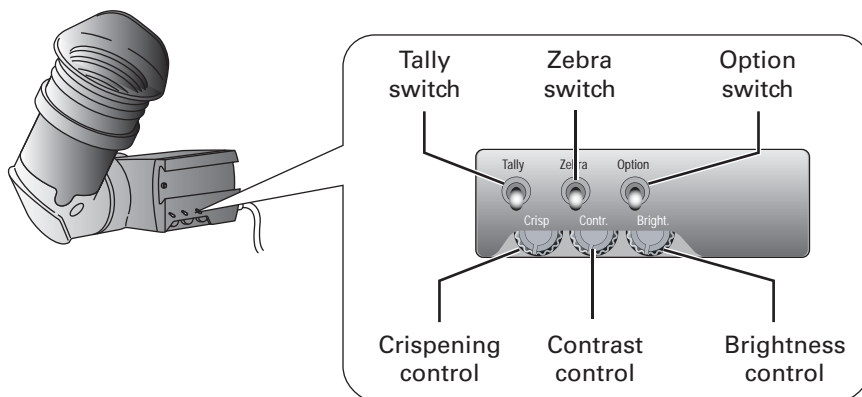
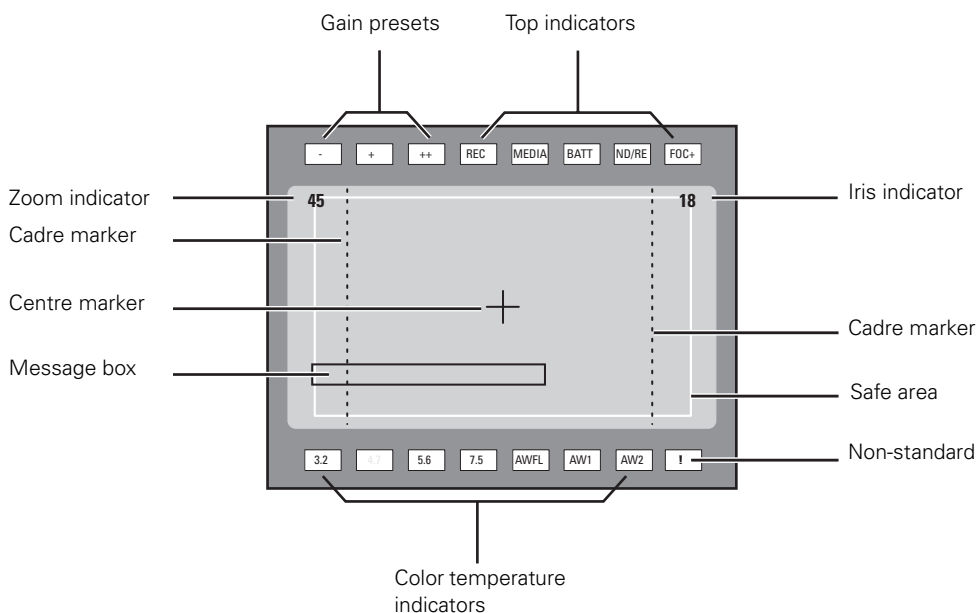

Figure 4-2. Viewfinder markers and indicators



Chapter 5

Operating instructions

5.1 Using the camera

Attach lens, viewfinder, microphone and any other accessories to the camera. Attach the triax cable or supply the adapter with power.

5.1.1 Switching on the power

1. On the Base Station set the master power switch to the on position (I). The green power light lights.
2. Set the camera **Power** switch of the camera to the on position .
3. Allow a few moments for the camera to perform a self-test and for the system to establish communications.



Note

To switch the camera to stand-by, set the **Power** switch of the camera to the  position.

5.1.2 Controlling the camera

There are several ways of controlling the camera:

- Using an MCP 400 connected to the C2IP network.
- Using an OCP 400 connected to the C2IP network or Base Station.
- Using the switches on the camera itself.
- Using the menu system to select functions.



Note

If you cannot access some camera functions or you wish to restrict access, refer to ["Access and Security" on page 69](#).

5.2 System Menu

The camera is operated via the viewfinder text display and the control system menu switches. The systems menu is viewed in the viewfinder and navigated by means of the **Rotary control** and the **Select button** which are both located at the front of the camera.

Figure 5-1. Menu control buttons

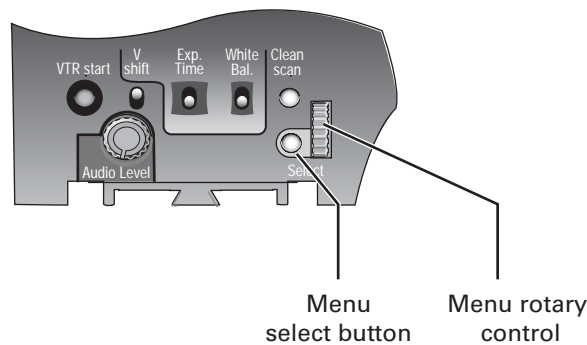

The functions of the camera are grouped into menus and sub-menus. There are seven different menus that are listed in the main menu as follows:

Viewfinder (VF) menu	>>
Lens menu	>>
Video menu	>>
Install menu	>>
Files menu	>>
Security menu	>>
Diagnostics menu	>>
Service menu	>>

Each of these menus gives you access to a particular group of functions. Spend some time using the controls and menus to discover the various functions. You will quickly learn to operate the camera intuitively.



Note

Some of the menu items may not appear if the user level is not set to 3.

5.2.1 Entering the System menu

Press the **Select** button after the camera is switched on, the message Menu off appears in the viewfinder. Press the **Select** button again while this text is showing, the MAIN menu appears in the viewfinder.

Figure 5-2. Main menu

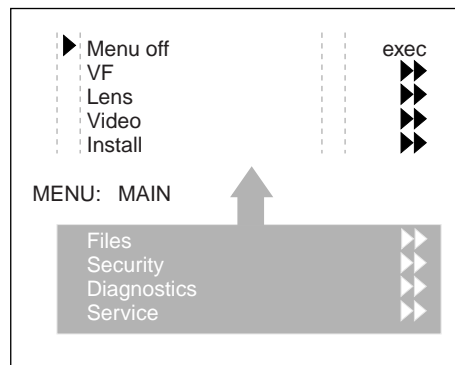

The **MAIN** menu screen shows five items. The name of the menu is shown below these. Four more items are hidden but become visible when you scroll down using the **Rotary control**. A cursor shows your position in the menu. The **Rotary control** moves the cursor up and down.

5.2.2 Finding your way

Use the **Rotary control** to move the cursor through the menu items. If a double arrow (>>) is visible, then pressing the **Select button** brings you one level lower in the menu system. Only five items are visible in each menu. Scroll up or down to see any additional items. When you first enter a menu (other than the **MAIN** menu) the cursor is positioned next to the first item.

The **TOP** and **PREVIOUS** entries are not immediately visible but are located above the first item. Use the **Rotary control** to scroll up to them.

- Select **TOP** to bring you back to the **MAIN** menu.
- Select **PREVIOUS** to go back to the menu that you were in before the current one.

The **LENS** menu, for example, shows the items displayed when you first enter the menu. The other items are available by scrolling up or down with the **Rotary control**.

Figure 5-3. Lens menu

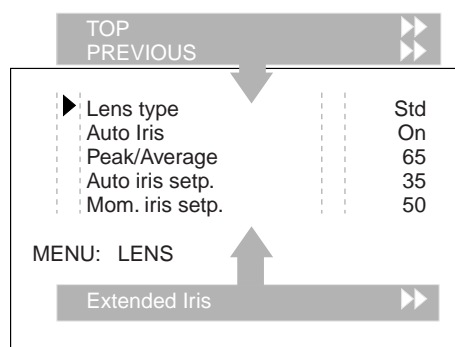

5.2.3 Leaving the System Menu

If you are deep within the menu structure, the recommended way of leaving the System menu is:

1. If necessary move the cursor to the left column with the **Select button**.
2. Scroll upwards with the **Rotary control** until the cursor points to **TOP** (this is the **MAIN** menu).
3. Press the **Select button**. The cursor now points to the **MENU OFF** item of the **MAIN** menu.
4. Press the **Select button** to leave the System menu.

If you do not use the menu it disappears after a few seconds. (This delay can be programmed in the **VF** menu.) However, when you press the **Select button** again you enter the System menu at the last position of the cursor and not at the top of **MAIN** menu. To prevent confusion the next time you enter the System menu, it is advisable to leave the menu by returning to the **MAIN** menu (**TOP**) and selecting **MENU OFF**.

5.2.4 Making changes

To find out where you have to go to change a function, consult the appendix to discover under which menu group or sub-group the function you want to change is located. If the cursor points to an item (and there are no double arrows to indicate a sub-menu) then the item pointed to has a value. The value can be:

- a toggle value (only two values)
- a list value (more than two values)
- an analogue value (variable from 00 to 99)
- unavailable (—).

If the value is unavailable it cannot be changed. This is indicated by three dashes (—). This can occur, for example, when a function is switched off. The analogue values associated with that function are then unavailable.

If there are only two values associated with the function, then pressing the **Select button** toggles between these two values. If a value is displayed next to a function that is one of several possible values, then pressing the **Select button** places the cursor in a list menu indicating the value currently selected. Use the **Rotary control** to point to a new value. Press the **Select button** to return the cursor to the function list.

If an analogue value is displayed next to a function name, then pressing the **Select button** places the cursor in front of the value and the **Rotary control** is used to change the analogue value. Press the **Select button** to return the cursor to the function list.

5.2.5 Undoing changes

If you make changes to the video settings in the Systems menu and you decide not to keep them, use the **Std. button** at the side of the camera to recall a standard set of values for the video parameters.

5.3 Assigning functions to buttons

The camera head has three assignable buttons, two on the side panel (SW1) and (SW2), and one on the lower front panel (VTR start). The operation of the RET and the VTR button on the lens can also be assigned. The function and behaviour (momentary or alternating) of these buttons are set in the **INSTALL/BUTTONS** menu.

5.3.1 Side panel

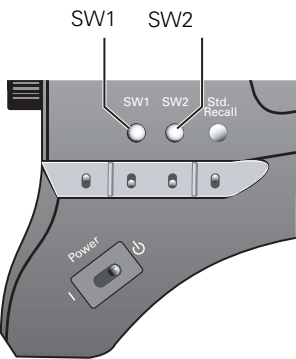
Location	Control	Possible assignments
	SW1	<ul style="list-style-type: none"> • Call • Switch to external video signal 1 • Switch to external video signal 2
	SW2	<ul style="list-style-type: none"> • Extended Auto Iris • Focus Assist • Switch to external video signal 1 • Switch to external video signal 2

5.3.2 Front

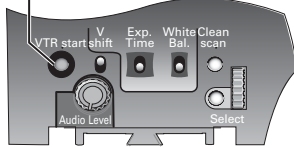
Location	Control	Possible assignments
	VTR Start	<ul style="list-style-type: none"> • Production intercom • Engineering intercom • Viewfinder zoom • Switch to external signal 1 • Switch to external signal 2

5.3.3 Lens

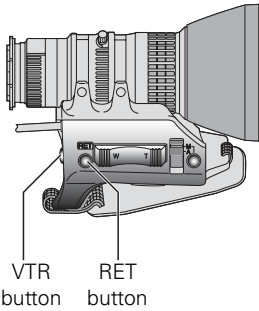
Location	Control	Possible assignments
	VTR button	<ul style="list-style-type: none"> • Production intercom • Engineering intercom • Viewfinder zoom function • Switch to external video signal 1 • Switch to external video signal 2
	RET button	<ul style="list-style-type: none"> • Viewfinder zoom function • Switch to external video signal

5.4 Video acquisition modes

In the **INSTALL** menu choose the video mode you wish to use for acquisition. The tables below show the output signals available for each video mode.

5.4.1 LDK 8000 Standard version

Acquisition format (imager)	HD-SDI outputs (camera)	Viewfinder indication	HDTV output (base station)	SDTV output (base station)
1080i59.94 Hz	A: 1080i59.94 B: VF signal	1080i59	1080i59.94	525i59.94 (NTSC)
1080i50 Hz	A: 1080i50 B: VF signal	1080i50	1080i50	626i50 (PAL)
720p59.94 Hz	A: 720p59.94 B: VF signal	720p59	720p59.94	525i59.94 (NTSC)
720p50 Hz	A: 720p50 B: VF signal	720p50	720p50	626i50 (PAL)

5.4.2 LDK 8000 SportCam version

The SportCam must be connected to the high-speed TriaxHD Base Station (LDK 4506) to obtain a dual-phase high-speed output for the high-speed acquisition modes.

Acquisition format (imager)	HD-SDI outputs (camera)	VF Menu setting	HDTV output (base station)	SDTV output (base station)
1080i59.94 Hz (non-high-speed)	A: VF signal B: VF signal	1080i59	PH1:1080i59.94 PH2:1080i59.94 1+2:1080i59.94	525i59.94 (NTSC)
1080i119.88 Hz (high-speed)	A: VF signal B: VF signal	1080i119	PH1: } 1080i119.88 PH2: 1+2: 1080i59.94	525i59.94 (NTSC)
1080i50 Hz (non-high-speed)	A: VF signal B: VF signal	1080i50	PH1:1080i50 PH2:1080i50 1+2:1080i50	626i50 (PAL)
1080i100 Hz (high-speed)	A: VF signal B: VF signal	1080i100	PH1: } 1080i100 PH2: 1+2: 1080i50	626i50 (PAL)
720p59.94 Hz (non-high-speed)	A: VF signal B: VF signal	720p59	PH1: 720p59.94 PH2: 720p59.94 1+2: 720p59.94	525i59.94 (NTSC)
720p119.88 Hz (high-speed)	A: VF signal B: VF signal	720p119	PH1: } 720p119.88 PH2: 1+2: 720p59.94	525i59.94 (NTSC)
720p50 Hz (non-high-speed)	A: VF signal B: VF signal	720p50	PH1: 720p50 PH2: 720p50 1+2: 720p50	626i50 (PAL)
720p100 Hz (high-speed)	A: VF signal B: VF signal	720p100	PH1: } 720p100 PH2: 1+2: 720p50	626i50 (PAL)

5.4.3 LDK 8000 WorldCam version

Acquisition format (imager)	HD-SDI outputs (camera)	VF menu setting	HDTV output (base station)	SDTV output (base station)
1080i59.94 Hz	A: 1080i59.94 B: VF signal	1080i59	1080i59.94	525i59.94 (NTSC)
1080i at 50 Hz	A: 1080i50 B: VF signal	1080i50	1080i50	626i50 (PAL)
1080p23.98 Hz	A: 1080psf47.95 B: VF signal	1080psf23	1080psf47.95	colour bar
	A: 1080psf59.94 B: VF signal	1080i59-23	1080psf59.94	525i59.94 (NTSC)
1080p24 Hz	A: 1080psf48 B: VF signal	1080psf24	1080psf48	colour bar
1080p25 Hz	A: 1080psf50 B: VF signal	1080psf25	108psf50	626i50 (PAL)
1080p29.97 Hz	A: 1080psf59.94 B: VF signal	1080psf29	1080psf59.94	525i59.94 (NTSC)
720p59.94 Hz	A: 720p59.94 B: VF signal	720p59	720p59.94	525i59.94 (NTSC)
720p50 Hz	A: 720p50 B: VF signal	720p50	720p50	626i50 (PAL)
720p23.98 Hz	A: 720p59.94 B: VF signal	720p59-23	720p59.94	525i59.94 (NTSC)
720p25 Hz	A: 720p50 B: VF signal	720p50-25	720p50	626i50 (PAL)
720p29.97 Hz	A: 720p59.94 B: VF signal	720p59-29	720p59.94	525i59.94 (NTSC)

5.5 Viewfinder preferences

Set up the viewfinder according to your own preferences; adjust viewing parameters, select markers, message boxes and on-screen display times in the VF menu.

Figure 5-4. Viewfinder controls

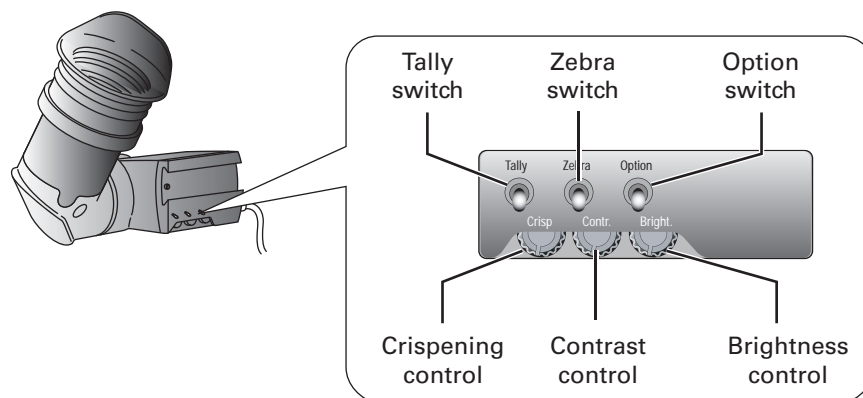

5.5.1 Viewfinder picture quality

Adjust the **Brightness** and **Contrast** controls according to your preferences. If you wish, use the **Crisping (peaking) control** to adjust the sharpness of the viewfinder picture (reduce the crisping when the gain is set to +++).

The dioptre of the viewfinder can be adjusted to suit your eyesight by turning the **Dioptre ring**. The range of the dioptre is +1 to -3.

5.5.2 Video level indication

Switch on the zebra function so that you are alerted in the viewfinder by a **Zebra pattern** in areas where high video levels occur. This diagonal line pattern warns you that the area affected has risen above a predetermined level of the full scale video exposure value. Go to the VF menu to set the video levels at which the zebra function works.

5.5.3 Tally indicators

The red **Tally indicator** at the front of the viewfinder and at the rear of the carrying handle light to indicate that the camera is on-air. The **Tally switch** is used to control the Tally indicator at the front of the viewfinder. When this switch is set to the **OFF** position, the **Tally indicator** does not light when the camera is on-air. The **Tally switch** does not control the tally indicator at the rear of the carrying handle.

When the camera is on-air, the **REC indicator** in the viewfinder lights. When the studio ISO signal is received, the **MEDIA indicator** lights.

Figure 5-5. Viewfinder markers and indicators

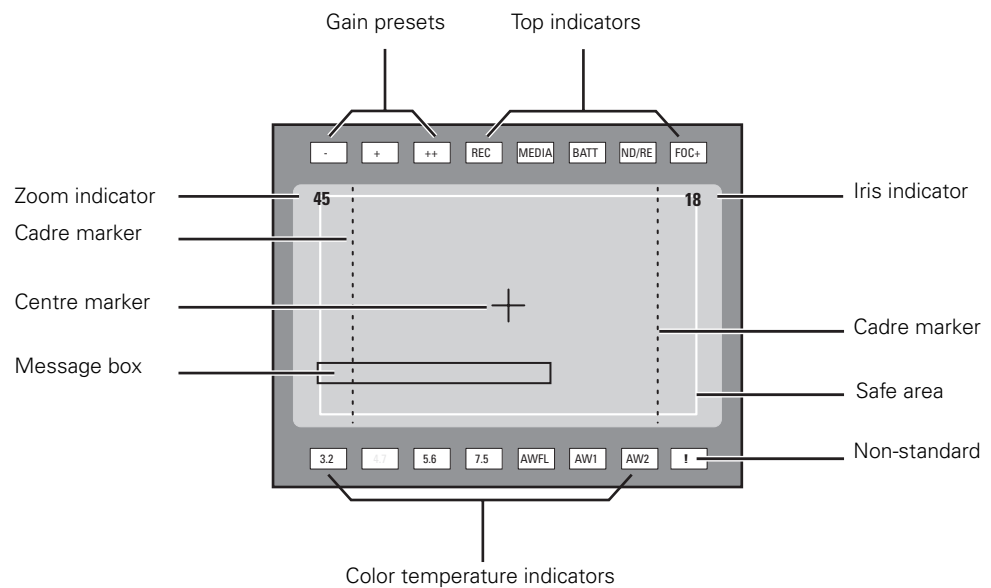

5.5.4 Viewfinder markers

Go to the $\vee\text{F}$ menu to select the markers you wish to see in the viewfinder. The following markers can be set up:

- The **Safe area marker** encloses an area that represents 80% of the whole viewfinder picture area. This is the minimum area seen on a TV-set.
- The **Message box** displays information messages. The length of time this box remains on the screen is set by the Info time item of the $\vee\text{F}$ menu.
- The **Centre cross** marks the centre of the picture.
- The **Cadre marker** is a dotted white line or a shaded area that shows the limits of a 4:3 (15:9 or 14:9) picture. Exterior marker shading can also be selected.

5.5.5 Focussing

A focus assist function can be switched on or off in the $\vee\text{F}$ menu. This function adds motion in the viewfinder to objects in sharp focus. The **FOC+ indicator** in the viewfinder lights when this function is on.

The viewfinder zoom function is another feature that helps you focus. This function enlarges the centre of the viewfinder image. Choose one of the following buttons and the way it operates (momentary or toggle) to control this function in the **INSTALL** menu:

- The VTR button on the camera,
- The VTR button on the lens,
- The RET switch on a zoom control when a large lens adapter is used.

When the viewfinder zoom function is in use, many of the viewfinder markers are switched off to improve the clarity of the display. The **FOC+ indicator** in the viewfinder flashes when the viewfinder zoom function is active.

5.6 Lens preferences

When you fit a lens to the camera you may need to adjust the back focus. Refer to the lens manufacturer's instructions to find out how to do this. The **LENS** menu allows you to choose and, if necessary, adjust other parameters to suit your lens type and your personal preferences.

5.6.1 Lens type

In the **LENS** menu select the lens type from two predefined settings: standard (**Std**) or wide angle (**WA**). This gives you the optimum shading settings for either a standard or wide angle lens. The lens manufacturer and the lens interface (analog or digital) are also selected in this menu.

5.6.2 Auto iris

If required switch on the auto iris function in the **LENS** menu. You can also select the parameters associated with the auto and the momentary iris in this menu.

5.6.3 Extended iris

The extended iris function automatically regulates the video signal level by adjusting the iris opening, the gain level and the exposure time to suit the ambient lighting conditions.



Note

Assign the **SW2** button to **extended iris** before using extended iris.

To switch on the extended iris function use the assignable button **SW2** at the left-front side of the camera. When this button is pressed once, the current value of the automatic extended iris function is displayed. Press the button twice in quick succession to switch between on and off.

When extended iris is on, the **Non-standard indicator** in the viewfinder lights, and gain and exposure controls are blocked. The parameters for the extended iris function are set in the **LENS** menu.

5.6.4 Precision focus



Note

Set the Lens Interface to **digital** in the LENS menu before using precision focus.

The camera supports the precision focus feature which is offered by some advanced (digital) lenses. This system automatically focuses the image within a user defined focus frame on the screen. When precision focus is enabled on the lens, the focus frame is superimposed on the viewfinder image. The frame can be moved and resized by the controls on the lens or on the focus handle.

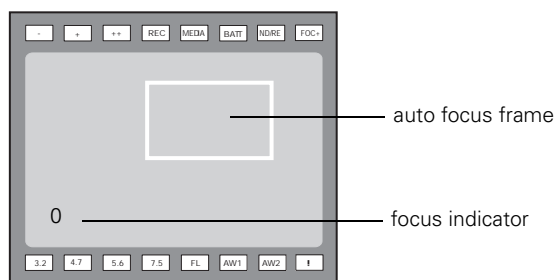

An indicator in the bottom left corner of the viewfinder screen shows the current focus information:

Indication	Focus information
--	focus is behind
-	focus is behind
0	area is in focus
+	focus is in front
++	focus is in front

Refer to the documentation of the lens manufacturer for more information about the precision focus feature.

5.6.5 Lens indicators in the viewfinder

The **ND/RE indicator** in the viewfinder lights when a lens range extender is selected.

The **Iris indicator** in the viewfinder shows the value of the iris opening (when enabled in the VF menu).

The **Zoom indicator** in the viewfinder shows the degree to which the lens has been zoomed out or in ranging from **0** (wide angle) to **99** (tele). It shows **50** if the lens does not support this feature.

5.7 Video preferences

The means used to control the camera depends on your work methods. A remote OCP can be used and a low user level can be selected to restrict the available camera functions.

Alternatively, video functions can be controlled on the camera itself. The following functions are available on the camera:

- Standard settings
- Test signal
- Gain selection
- Optical filter selection
- Colour temperature
- Auto-white balance
- Exposure time
- Black stretch
- Auto skin detail

Many other video functions such as detail, black, gain, knee, gamma, matrix and white limit functions are available in the VIDEO menu.

5.7.1 Standard settings

To ensure that some of the camera functions are not set to unusual values, a standard file has been defined that contains the default values for most video functions. The table in the Appendix lists the values that are set when the standard file is recalled.

To recall the standard values for the various video functions, press the green **STD button** on the left-front side of the camera and hold it for two seconds. The standard values only take effect when the camera is not on-air.

The standard file can be selected as either a factory or a customer standard file. Changing the standard file can only be done in the System security menu if the owner card or the PIN code is used.

The **Non-standard indicator** lights when the video settings are not set to their standard value, for example, when exposure is not set to nominal. It also lights when black stretch or extended auto iris is on and if AWC, FL50 or FL60 is selected with the colour temperature selector.

Figure 5-6. Video control buttons

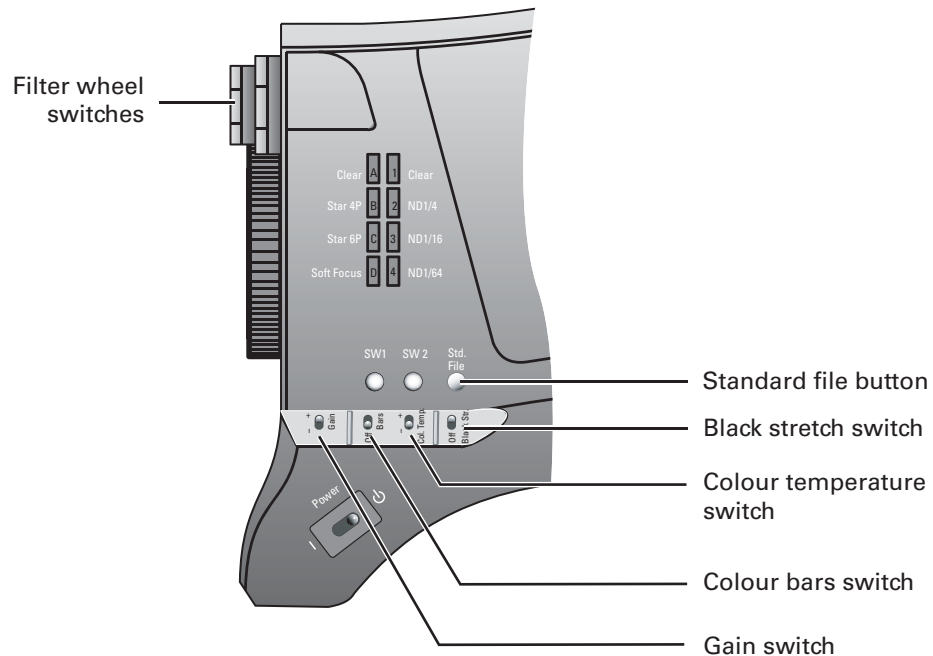

5.7.2 Test signal

The left-front side panel of the camera has a **Colour bars switch** for switching on a colour bar test signal. The colour bar is the standard test signal that is used to set up and check the camera before use. When the colour bar is selected the following functions are temporarily set to **Off**:

- Black stretch
- White limiter
- Zebra
- Safe area (VF)
- Cadre (VF)

The lens iris closes automatically when the colour bars are switched on.

5.7.3 Gain selection

Depending on the available light levels it may be necessary to adjust the gain of the camera. The gain is selected via the **Gain switch** on the left-front side of the camera.

1. When this switch is pressed initially, the current value of the gain in dB is displayed in the viewfinder.
2. Holding the switch in the up or down position for a very short period selects one of the five master gain settings: -, 0, +, ++ and +++.
 - The actual value of the gain in dB is assigned to these symbols in the **INSTALL** menu.
 - The **Gain indicators** in the viewfinder light to indicate the value selected. (The + and ++ indicators light when the gain is +++)

Symbol		Gain
-	is always	-6 or -3dB
0	is always	0dB
+	can be set to	3, 6 or 9dB
++	can be set to	6, 9 or 12dB
+++	is always	12 dB

Variable gain

The gain switch can also be used to vary the gain continuously between its minimum and maximum value.

1. Hold the switch continuously in the up or down position until you see the value in the viewfinder change in steps of 0.1dB.
2. Release the switch when you reach the value you want.
3. Using the switch momentarily again sets the gain to the nearest standard value.

5.7.4 Optical filter selection

A neutral density filter and a special effect filter can be placed in the path of the optical signal to modify the incoming light. The filters are selected via the **Filter switches** at the top-front of the camera. These filters can be used, for example, to control depth of field or exposure levels.

The camera does not need colour optical filters to be able to white balance correctly. The range of the auto-white balance is so wide (from 2500K to 20000K) that there is never any need to use colour filters to obtain the correct white. Rotate the switches to move the optical filter wheels.

The outer (bigger) filter switch has four positions:

Position	Filter
1	Clear
2	ND 1/4 filter (2 stops)
3	ND 1/16 filter (4 stops)
4	ND 1/64 filter (6 stops)

The inner (smaller) filter switch also has four positions:

Position	Filter
1	Clear
2	4-point star
3	6-point star
4	Soft focus

The status of the filter wheels is displayed in the viewfinder for a few seconds. The **ND/RE indicator** in the viewfinder lights when an ND (Neutral Density) filter is selected.

5.7.5 Colour temperature selection

For true colour reproduction the ambient lighting conditions must be compensated for by selecting a value for the colour temperature. The standard file setting is 3200K (normally used for tungsten and indoor lighting). Two other reference colour temperatures are available: 5600K (for outdoors, clouded conditions) and 7500K (for outdoors, clear blue skies).

The memory positions (FL50, FL60, AW1 and AW2) are available to store the results of the auto-white measurement process. The memory positions are filled with measured values using the automatic white balance switch at the front. The FL positions are recommended for shooting with fluorescent light.

A continuous automatic white balance position (AWC) is also available. This function continuously measures the white balance and adjusts accordingly. It can be used when a constant colour balance is required under changing lighting temperatures (sunsets, indoors/outdoors use).

In the auto-white positions an electronic colour filter can be adjusted in the VIDEO menu. This varies the colour balance to obtain warmer or colder colour effects. When an automatic white balance process is performed, the electronic colour filter is reset to its default value.

Selecting the colour temperature

The up/down **Colour temperature switch** on the left-front side of the camera allows a choice between:

Three preset colour temperatures:

- 3200K (3.2K) - for indoor lighting conditions
- 5600K (5.6K) - for outdoors, clouded conditions
- 7500K (7.5K) - for outdoors, clear blue skies

Four memory positions:

- FL50 - memory position for 50Hz fluorescent light (matrix is set to CoolFL and exposure to 50Hz.)
- FL60 - memory position for 60Hz fluorescent light (matrix is set to CoolFL and exposure to 60Hz.)
- AW1 - memory position 1
- AW2 - memory position 2

An automatic continuous white position:

- AWC - continuous measurement (2500K to 20000K)

When the switch is first pressed, the viewfinder displays the current value.

Select a new value by scrolling up or down through the available values.

The **Colour temperature indicators** in the viewfinder light to show which position is selected. None of these indicators light when AWC is selected, but the **Non-standard indicator** lights.

The viewfinder also displays the actual value of a measured colour temperature. The range of the auto-white balance is from 2500K to 20000K.

Variable colour temperature

The **Colour temperature switch** on the left-front side of the camera can also be used to vary the colour temperature continuously between its minimum and maximum value (2500K to 20000K).

1. Hold the switch continuously in the up or down position until you see the value in the viewfinder change in steps of 10.
2. Release the switch when you reach the value you want.
3. Using the switch momentarily again sets the colour temperature to the nearest standard value.

Auto-white balance

If the reference colour temperatures do not match your lighting conditions carry out the auto-white procedure as follows:

Figure 5-7. Auto white balance switches

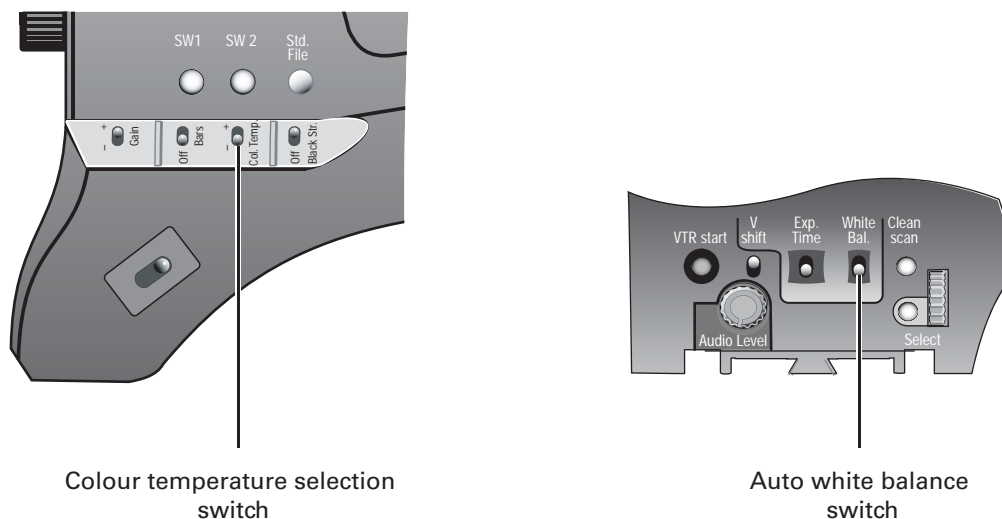

1. Use the **Colour temperature switch** to select one of the memory positions FL50, FL60, AW1 or AW2 in which to store the measured colour temperature value.
2. Press once on the **White balance switch** at the front of the camera to start the automatic white balance procedure. The following appears in the viewfinder:

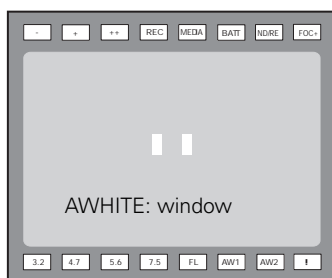

**Note**

If you did not select one of the memory positions FL50, FL60, AW1 or AW2, the 'Precondition fail' message appears in the viewfinder.

3. Point the camera so that the reference white surface is between the two small white boxes.
4. Press the **White balance switch** again to start the measurement procedure. A message indicating that the process is running appears.

**Note**

If there is insufficient light, the 'Light level too low' message appears in the viewfinder.

5. When the process is completed (within a few seconds) the **OK** message and the measured temperature appear in the viewfinder.

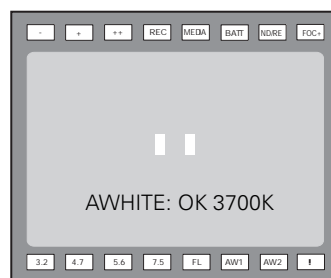

The measured colour temperature is now stored in the selected memory position and can be recalled as required.

**Note**

During the auto-white measurement process iris is set to Auto and 90% and the knee is turned off.

Black balance is not necessary with this camera because of the continuous automatic black control circuits.

5.7.6 Exposure time

The exposure time values of 1/200, 1/500 and 1/1000 of a second are used to capture fast moving objects so that these can be played back sharply in slow motion. The value selected depends on the speed of the moving object.

Figure 5-8. Exposure time controls

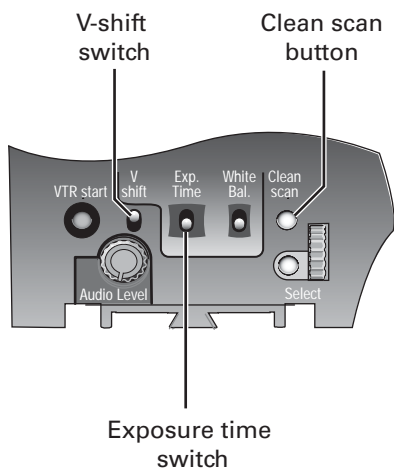

Note

Increasing the exposure speed lowers the camera sensitivity proportionally.

Selecting the exposure time

The momentary up/down **Exposure time switch** gives a choice of exposure time settings. If an exposure time other than nominal is selected, the **Non-standard indicator (!)** in the viewfinder lights.

Value	Function	Shutter blade
Nom.	- nominal setting	rotating
Cl. scan	- enables the exposure to be varied (normal or extended)	stopped or rotating
1/200	- for fast moving objects	rotating
1/500	- for fast moving objects	rotating
1/1000	- for fast moving objects	rotating
50 Hz *	- shooting with 50Hz lighting (adjustable)	rotating
60 Hz *	- shooting with 60Hz lighting (adjustable)	rotating

* not available for high speed video modes of the SportCam version

Lighting

The exposure selection also includes lighting control positions which can be used when shooting with lighting that is operating at a different frequency to the camera. There are two positions; 50 Hz and 60 Hz. Each of these positions can be varied further in a range from -10 to +10. To reduce flicker select the frequency closest to the frequency of the lights and then vary the lighting control in the **INSTALL** menu to obtain the best result. (Lighting control is not available in the SportCam version.)

5.7.7 Shooting screens

Sometimes when shooting TVs or computer monitors a horizontal bar can be seen across these screens in the viewfinder. There are two ways of removing the noise bar from the picture depending on the frame frequency of the display:

- For displays with the same frame frequency as the camera, for example TV sets, use the V-shift facility. V-shift can also be used to remove any colour shifts that might occur when shooting pictures produced by DLP-type devices.
- For displays with a higher frame frequency, for example computer monitors, use the Clean Scan facility.

Vertical shift (V-shift)

Sometimes when shooting TV screens or monitors with the same display frequency as the camera, for example TV sets, a horizontal black bar is seen in the viewfinder because the camera is blanking while the TV is not. The **V-shift switch** shifts the camera blanking.

The **V-shift switch** at the front of the camera is spring-loaded with a central rest position. Holding the switch in the + or - position moves the bar up or down so that it is no longer visible in the viewfinder. This function is only available when the camera is used in the stand-alone mode. It is not active when the camera is genlocked or on-air.

When the camera is genlocked, use the V-shift function in the **INSTALL** menu.

Clean scan

When shooting computer monitors with higher frame frequencies than the camera use the Clean Scan function as follows to avoid horizontal bars in the picture:

1. Press the **Clean Scan button** at the front of the camera for about two seconds to directly access the variable exposure (clean scan) function. The **CLEAN SCAN** submenu appears in the viewfinder.
2. Use the **Rotary control** to change the value and so remove the noise bar.
3. If a more accurate adjustment is required set the **CL . SCAN** item to **EXTENDED**. (Set the mode to **NORMAL** if a smear effect occurs.)
4. Set the **UNIT** item to the preferred read out, **Hz** or **mSec**.

When you are finished shooting the monitor press the **Clean Scan button** for two seconds to switch off the Clean Scan function. (Exposure time returns to its previous non-variable setting.) When Clean Scan is on, the **Non-standard indicator** in the viewfinder lights.



Note

Do not shoot highlights in the Clean Scan mode as this may cause a smear effect.

5.7.8 Reverse scan

When the camera is used in a mounted at a rotated angle use the reverse scan feature to digitally rotate the camera's image to compensate. Go to the `INSTALL\REVERSE SCAN` menu to switch reverse scan on or off and to select the scan mode (horizontal, vertical or both rotations).

5.7.9 Black stretch

The black stretch function changes the level of detail in the shadow areas of the picture without effecting the rest of the picture. Set the **Black stretch switch** to the **On** position to switch on the black stretch function.

The Video menu allows you to adjust the black stretch parameters. Black stretch values above 50 produce more detail in the shadow areas, while values lower than 50 reduce the detail (this is often referred to as Black Press). The default value is 99.

When black stretch is switched on the **Non-standard indicator** in the viewfinder lights.

5.7.10 Auto skin detail

Use skin detail to change the detail level in a selected colour range. Decreasing the detail level of a person's skin colour softens only the skin tones. But not only skin colours can be selected, for example, decrease the detail level of a soccer field to accentuate the soccer players or increase the skin detail level to accentuate a rough surface.

Carry out the Auto skin detail procedure as follows:

1. In the `VIDEO\SKIN\SKIN` menu, select the memory position skin 1 or skin 2 (not 1+2).
2. Place the cursor in front of the `VIDEO\SKIN\AUTO` item.
3. Press the **Select button**. The following appears in the viewfinder.

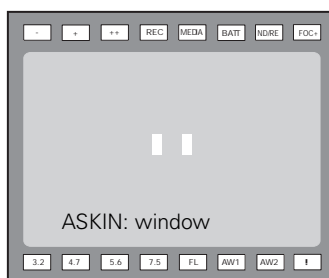

4. Point two small white boxes at the intended surface.
5. Press the **Select button** to start the measurement procedure (the iris is set to Auto). The process running message appears:

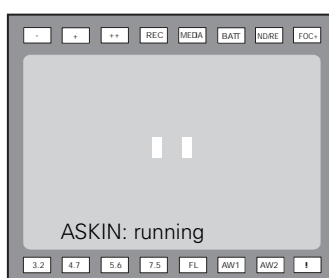

6. When the process is completed (within a few seconds) the **OK** message appears in the viewfinder.
7. Adjust the skin detail level with the `VIDEO\SKIN\SKIN LEVEL` item. Decrease the value below 50 to soften the selected area. Increase the value above 50 to add extra detail..

5.8 Controls on the TriaxHD adapter

Figure 5-1. Rear controls

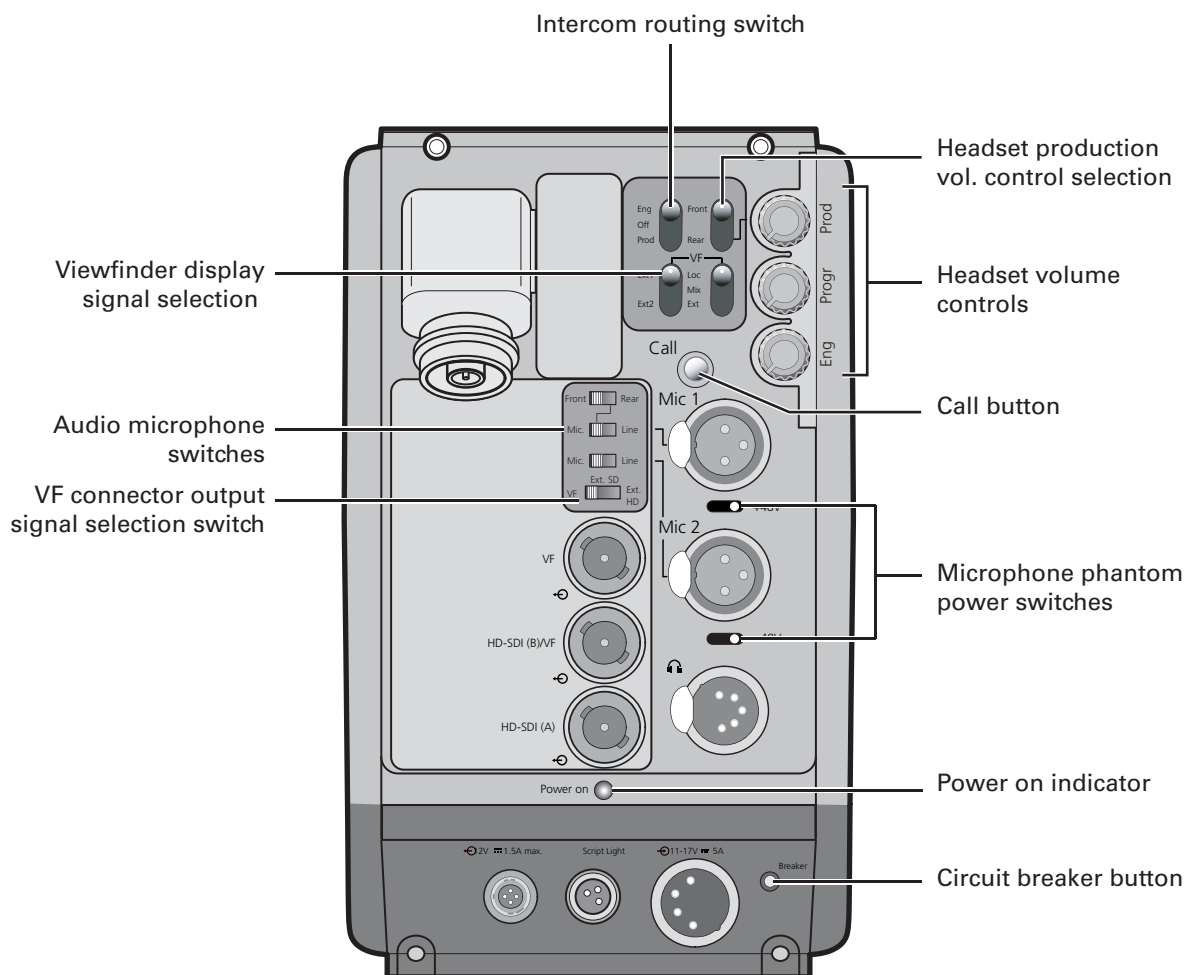

5.8.1 Powering the camera

The power supply for the camera and TriaxHD adapter is normally supplied via the Triax cable from the Base Station. The power on indicator lights when power is supplied and the camera power switch is set to the on position **I**.

When power is supplied via the Triax cable, an output power socket supplies +12 Vdc, 1.5A maximum for powering accessories.

It is also possible to operate the camera without a Triax cable by supplying a +12 Vdc supply to the DC input socket. The BATT indicator in the viewfinder lights if the camera supply voltage is less than 11V when using an external supply.

If excessive current flows in the camera or adapter, the circuit breaker trips and shuts off power to all the units. If this happens check the units for faults and if necessary take corrective action before pressing the circuit breaker button to reset the power.

5.8.2 Selecting monitoring signals

Viewfinder display signal

The viewfinder can display local or external video signals. Two switches determine the signal that is displayed in the viewfinder. The selection made with these switches also determines the VF connector output. Viewfinder display signal switch:

- Set to LOC to display the local camera Y signal in the viewfinder.
- Set to MIX to display a mix of the local camera Y signal and external signal.
- Set the switch to EXT to display the external signal 1 or 2.

The external signal selection switch determines which external signal from the Base Station, either EXT1 or EXT 2, is displayed in the viewfinder.

Figure 5-9. Viewfinder signal display switches

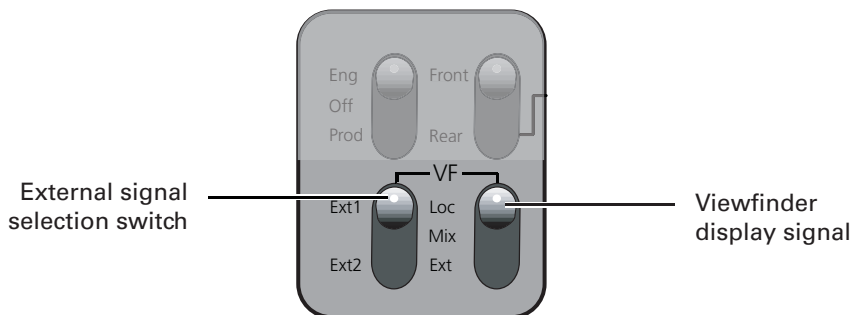

Output monitoring signal

The monitoring output selection switch determines the signal available at the VF output connector. The output can be switched between:

- VF: the analog viewfinder signal (Y only),
- Ext SD: the external signal from the base station (SD-format, CVBS). or
- Ext HD: the scaled external signal from the base station (HD-format, Y only).

Figure 5-10. VF output connector signal

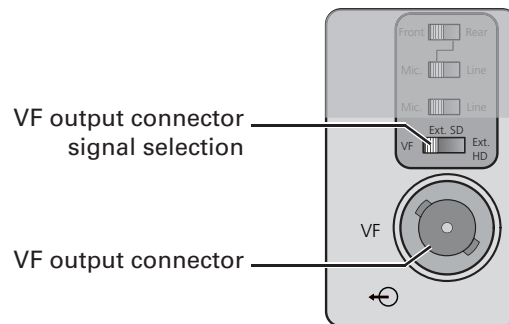

5.8.3 Using audio

Two high quality audio channels are available in the Triax mode. Set the gain levels (-22 to -64 dB) for these channels in the **AUDIO** section of the **INSTALL** menu. A high-pass filter for each channel can also be switched on via this menu.

Audio channel 1

The channel 1 input socket selection switch selects either:

- the socket at the front-right of the camera, or
- the **Mic 1** audio channel 1 connector at the rear of the adapter

as the input for channel 1.

The rear input level switch selects either a line level input or a microphone level input for the channel 1 rear connector. The line level input sensitivity is 32dB lower than the microphone input sensitivity.

The switch under the **Mic 1** socket selects a phantom power supply (48V) for the rear socket. Phantom power (48V) is always present on the front-right microphone socket.

Figure 5-11. Audio channel switches

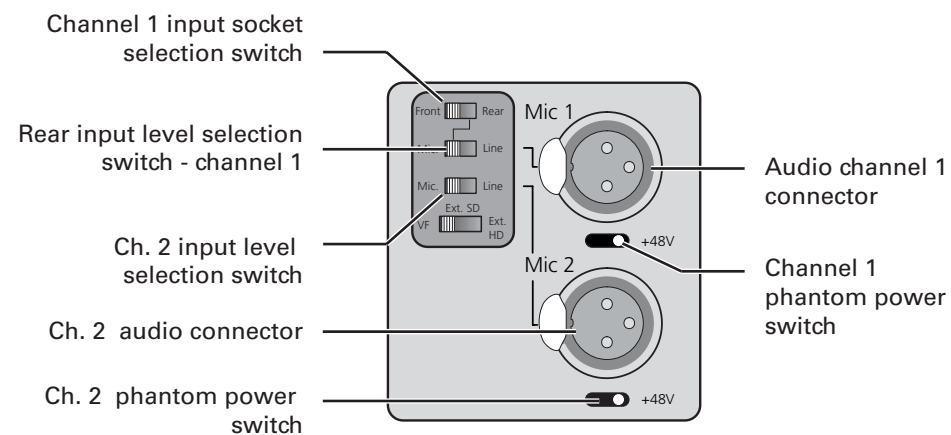

Audio channel 2

The channel 2 rear input level switch selects either a line level input or a microphone level input for the channel 2 rear connector (**Mic 2**). The switch under the **Mic 2** socket selects a phantom power supply (48V) for the rear socket.

5.8.4 Intercom

Three intercom channels – production (Prod), programme sound (Prog) and engineering (Eng) – are sent from the Base Station to the camera operator's headset. The camera operator's intercom microphone signal is sent to the Base Station. Routing and volume controls for the intercom are on the back of the adapter.

Figure 5-12. Intercom controls

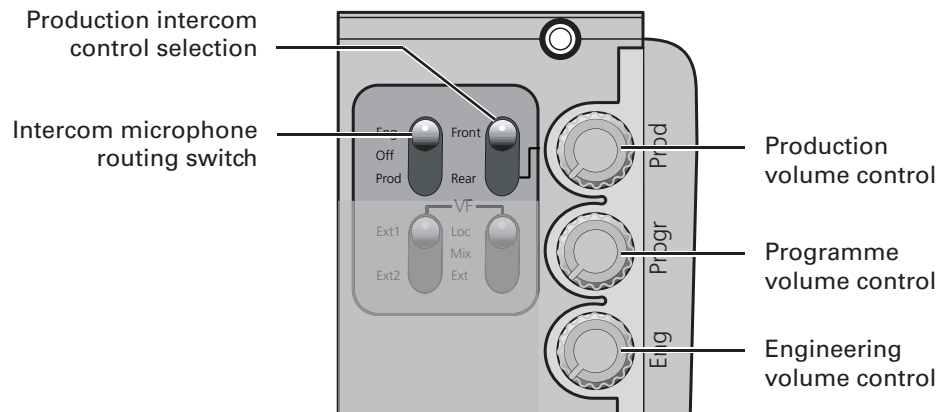

Production intercom volume control selection

Use this 2-position switch to control the volume of the production signal in the intercom either at the front of the camera or at the rear of the adapter.

Intercom microphone routing switch

This 3-position switch routes the camera operator's intercom microphone signal to engineering (Eng) or production (Prod), or turns it off. The VTR Start button at the front of the camera, or the VTR button on the lens, can be assigned to send this intercom signal to production, regardless of the position of this switch.

Intercom headset volume controls

- **Prod** - adjusts the volume of the production signal to the camera headset when selection switch is in the **REAR** position.
- **Prog** - adjusts the volume of the programme signal to the camera headset.
- **Eng** - adjusts the volume of the engineering intercom signal to the camera headset.

The **INTERCOM** section of the **INSTALL** menu contains various settings for all these channels. Signals for left and right headset muffs and sidetone levels can be selected. Intercom microphone amplification levels, phantom power supply and microphone on/off switches are also available in this menu.

Tracker intercom

A tracker can connect a headset to the side of the adapter to receive the intercom channels from the Base Station and the camera operator's microphone signal. The tracker's microphone signal is passed to the camera operator and to the Base Station.

5.8.5 Communication

Call button

Press this momentary button to send a signal to the control panels calling for attention. The ND/RE indicator in the 1.5-inch viewfinder shows when a call signal is sent or received.

The call button can also be used to playback a voice mail message that has been recorded in the Base Station. Press once to start playback; press again to stop.

Data channel

The Aux connector on the side of the adapter provides analogue control signals and allows for the connection of a two-way private data channel between camera and Base Station. In the `INSTALL` menu, the tracker microphone and engineering intercom channels can be selected to carry the private data instead of their normal function.

Tracker tally signal

The tracker connector on the side of the adapter, as well as providing full intercom facilities for the dolly or crane driver, also carries a tally signal and a +12 Vdc power supply. This allows an external on-air lamp to be used.

5.9 Managing files

You can have access to 15 different files. This number can be extended by using additional scene file camera cards. The Files menu is used to recall and store these files. There are two types of file:

- scene files
- operator files

A scene file contains values related to the picture performance. The operator file contains values related to the set-up of the camera (viewfinder, lens and installation parameters). The tables in the Appendix indicate the functions that are stored in the scene file and those functions that are stored in an operator file.

5.9.1 Scene files

Four scene files are stored in the camera itself (SCAM1, SCAM2, SCAM3 and SCAM4). Another four scene files can be stored on the camera card (SCARD1, SCARD2, SCARD3 and SCARD4). A STANDARD scene file (preselected as either factory or customer defined) is stored in the camera.



Note

The standard customer scene file is stored via the SECURITY menu, not the FILES menu. The decision to use the factory defined file or the customer defined file as the standard file is also made in this menu.

The FILES menu enables the scene files to be stored and recalled using the store and recall entries of the menu system. If the message NOK is displayed, then the old values are restored. If the camera is on-air when a scene file is recalled, then the recalled values do not become active until the camera goes off air.

5.9.2 Operator files

The FILES menu also allows the recall of the operator file stored in the camera (OCAM1) or one of the two operator files (OCARD1 and OCARD2) stored on the camera card. These files contain information for setting up the non-video configuration of the camera. A STANDARD operator files (factory or customer defined) is stored in the camera.



Note

The standard customer operator file is stored via the SECURITY menu, not the FILES menu. The decision to use the factory defined file or the customer defined file as the standard file is also made in this menu.

5.9.3 Standard files

The green STD button on the left-front side of the camera recalls the standard scene file. This file contains standard parameters for the picture performance. A standard operator's file can be recalled via the FILES menu. This file contains parameters for the set-up of the camera.

5.9.4 Customer standard files

You can define a customer standard file for the standard scene file and for the standard operator's file. The contents of the customer files for both these standard files is stored via the SECURITY menu. The selection of a factory defined or a customer defined file for use as a standard file is also made in this menu. You can only access the functions of the SECURITY menu with an owner's card or the PIN code of the camera.

5.10 User levels

The user level function in the SECURITY menu restricts access, in varying degrees, to the operational controls of the camera. You can only access the functions of the SECURITY menu with an owner's card or the PIN code of the camera.

5.10.1 Selecting the user level

There are four user levels: user0, user1, user2 and user3. The purpose of the user levels is to restrict the set of functions which can be changed by whoever is using the camera. In this way a more centralized and uniform control can be achieved and the danger of the camera operator accidentally changing critical functions while shooting is reduced.

User level 0 is a special protection level which locks most of the operational controls of the camera. Use this level to ensure that a camera that has been set-up is not tampered with. User level 0 is not normally used for operational purposes as it is too restrictive for normal circumstances. The recommended minimum user level is 1. For full control set the level to 3. When you switch off the power, the access rights that were obtained by the use of the PIN code are disabled and the camera starts at the assigned user level when switched on again.

Disable camera

The disable camera function is a protection function which prevents unauthorised interference with the camera and provides an additional level of security. Setting disable camera to **ON** is similar to using User level 0 to protect the settings of the camera.

5.11 Access and Security

5.11.1 Camera cards

Three camera cards are delivered with each camera. These comprise of two user's cards and one owner's card.

Figure 5-13. Camera cards

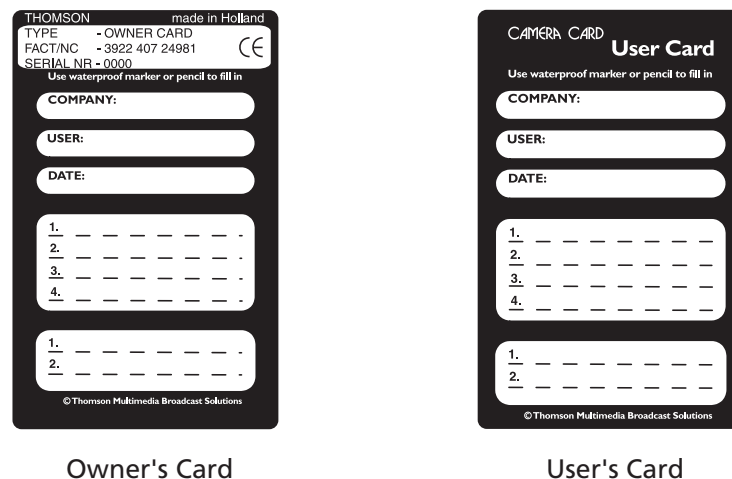

The owner's card has three functions:

- As an access control device to the security settings of the camera.
- As a storage device for four scene files.
- As a storage device for two operator files.

The owner's card is unique to every camera. Owner's card and camera must have the same serial number. An owner's card is linked to the serial number of the camera and cannot be used as an owner's card for another camera.

The user's card has two functions:

- As a storage device for four scene files.
- As a storage device for two operator files.

Scene files

Both the user's card and the owner's card allow four different scene files to be stored on the card. The recall and storage of a scene file is carried out via the Files menu of the menu system. A scene file contains information relating to the video settings.

Operator files

Both the user's card and the owner's card allow two different operator files to be stored on the card. The recall and storage of a operator file is carried out via the Files menu of the menu system. An operator file contains information relating to the set-up of general camera preferences.

5.11.2 Access control

The owner's card or the PIN code is used to access special set-up and security features of the camera. Inserting the owner's card into the associated camera always gives direct access to the Security menu (PIN code is not required). If you select the Security menu without this card inserted, you must enter the correct PIN code to gain access to this menu.

PIN code

The PIN code of the camera can be viewed and changed in the Security menu. The camera's PIN code when it leaves the factory is set to 0000. It is strongly advised that this code be changed by the owner on receipt of the camera. This ensures added protection against unauthorised access to the Security menu.

5.11.3 Camera card slot

Insert your camera card into this slot with the chip on the card facing the front of the camera. Push the card home until it fits snugly. A camera card is not required for normal operation of the camera.

Figure 5-14. Camera card slot

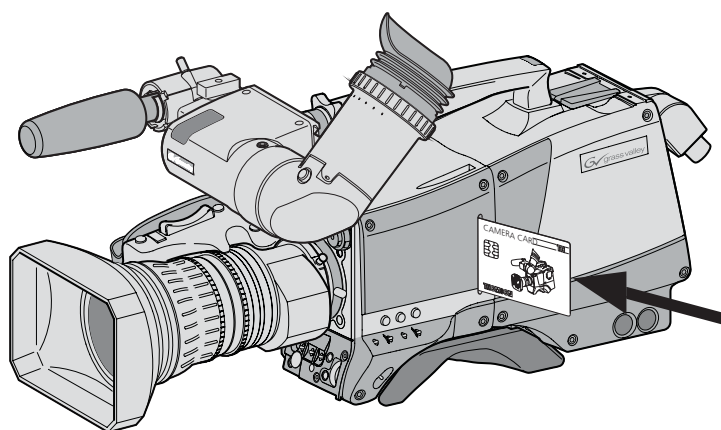

Note

Only use an original camera card. Store the owner's card in a safe place.



Note

An LDK 8000 SportCam will only read LDK 8000 SportCam cards.

Chapter 6

Menu structure and contents

6.1 Menu structure

The structure of the main menus and their submenus are shown on the following pages. The first column shows the user level (0 to 3). You only see menu functions whose user level is equal to or less than the user level set on your camera. Where appropriate, the default value of the function in the standard factory file is shown after the function.

6.1.1 Top menu structure

Viewfinder (VF) menu	>>
Lens menu	>>
Video menu	>>
Install menu	>>
Files menu	>>
Security menu	>>
Diagnostics menu	>>
Service menu	>>

Viewfinder (VF) menu - contains the functions which determine how items in the viewfinder are displayed.

Lens menu - controls various aspects of the lens.

Video menu - contains those functions which affect the picture quality.

Install menu - contains the functions that are used to set up the general configuration of the camera.

Files menu - allows values to be stored in scene and operator files, and allows these files to be recalled as required.

Security menu - used by the camera owner to set user levels and to control access to the camera, or to store the customer (scene and operator) default files.

Diagnostics menu - provides information on the current status of the camera. No values can be changed in this menu.

Service menu - contains service item for advanced camera configuration.

6.1.2 VF menu structure

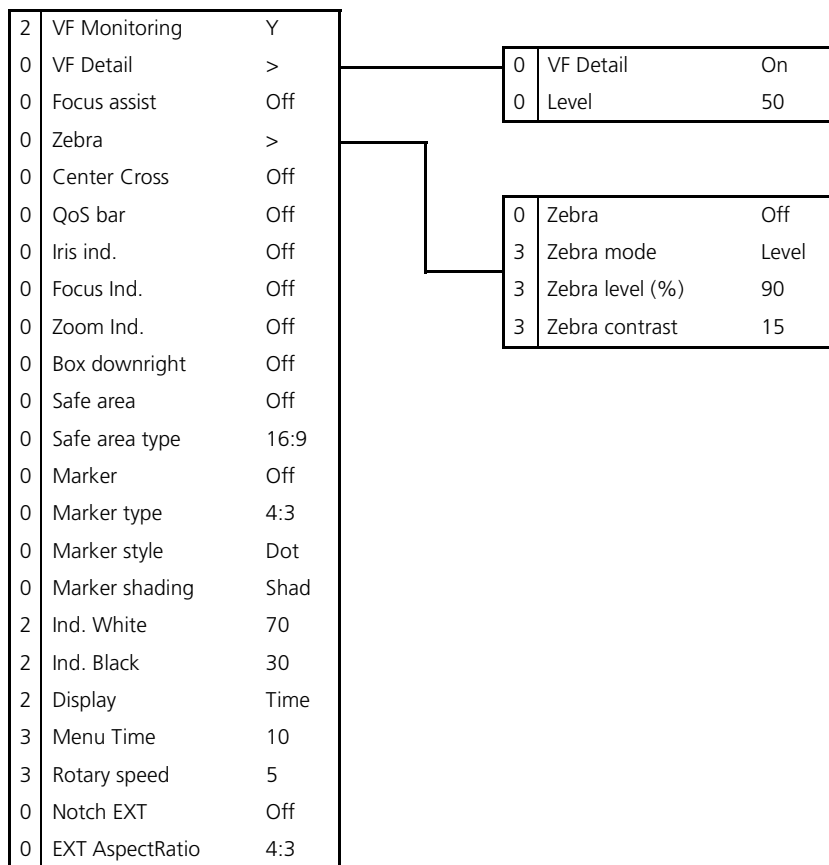

6.1.3 Lens menu structure

0	Lens type	Std		
0	Autolris	Off		
3	Peak/Average	64		
3	Autolris Setpoint	35		
3	Mom.Iris Setpoint	50		
0	RE Iris Comp.	Off		
3	Autolris Const	>	3	Autolris Gain 5
3	Ext.Iris Const	>		
0	Handgrip Zoom	On		
3	Zoom speed	5		
3	Zoom curve	0		
3	Zoom/Focus	Loc		
3	Lens I/F	Analog		
3	Lens I/F State	NotOK		
			S	Gain Speed 5
			S	ExpTime Speed 4
			3	Min Iris F16
			3	Max Iris F2
			3	Min. Exp.Time 1/500
			3	Max. Gain (dB) 15

6.1.4 Video menu structure

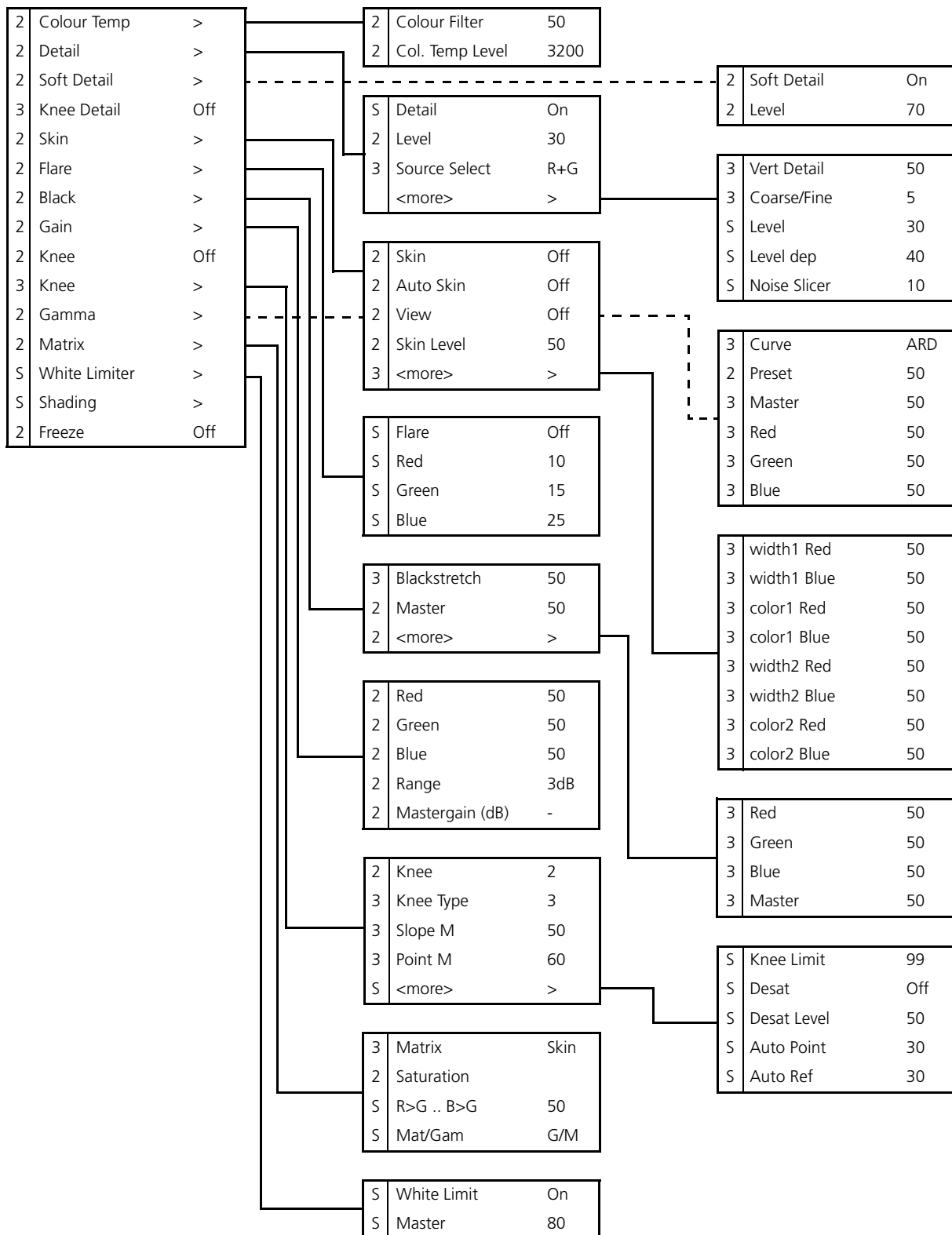

6.1.5 Install menu structure (Triax version)

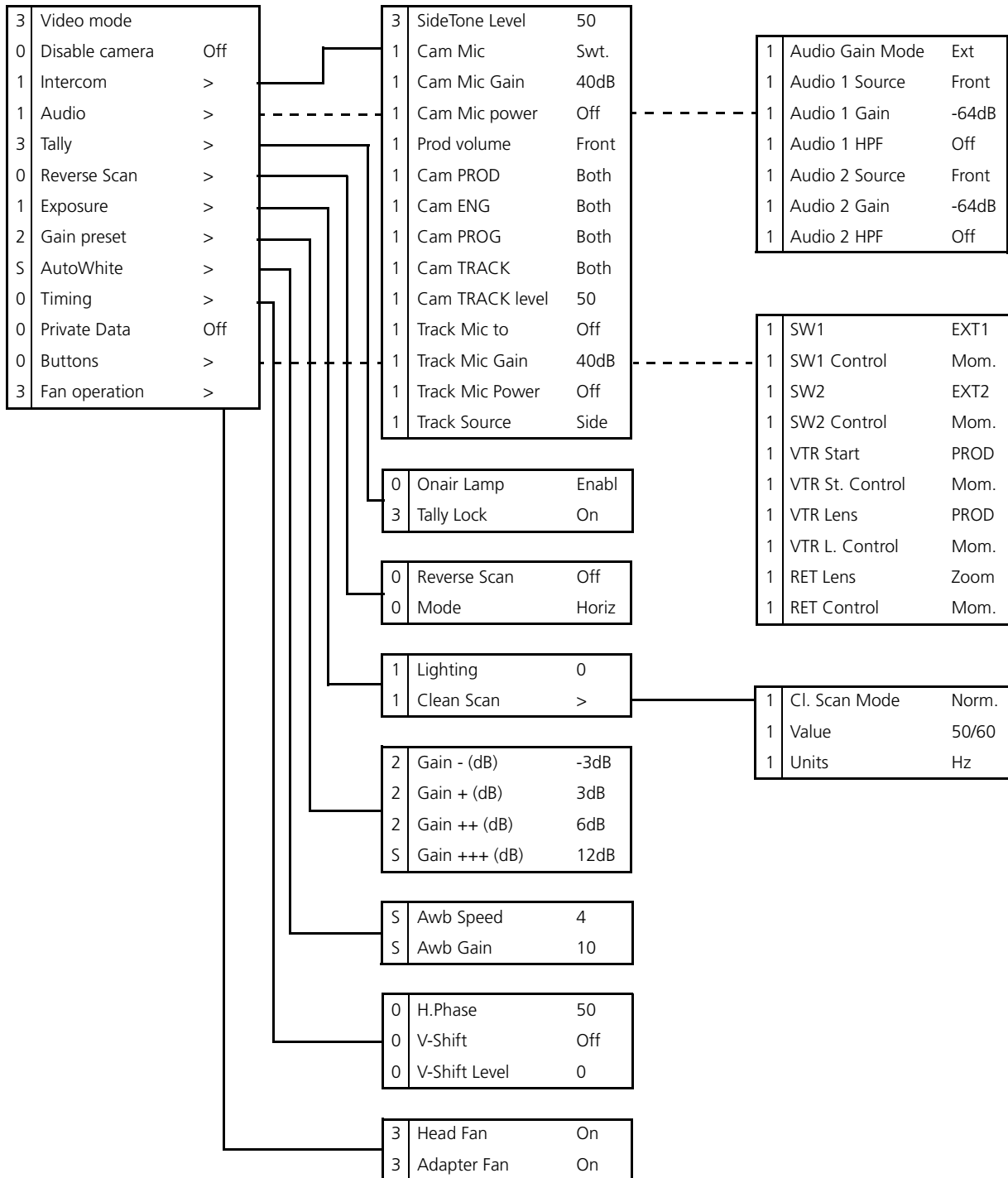

6.1.6 File menu structure

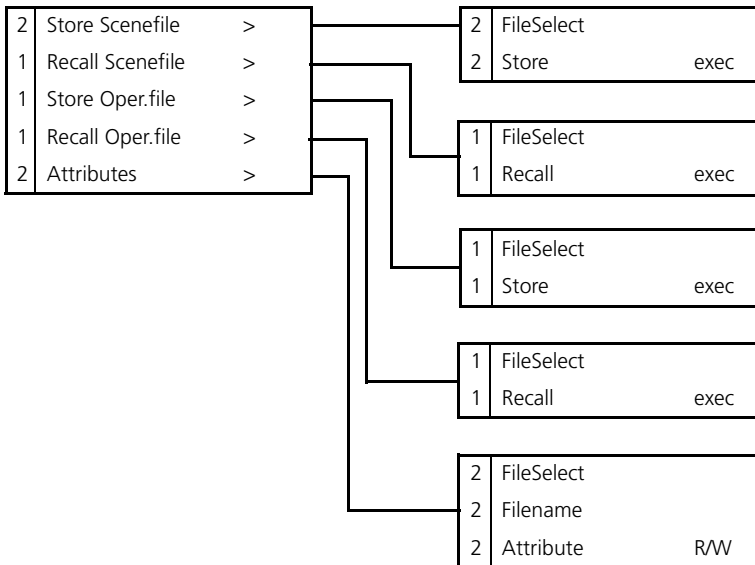

6.1.7 Security menu structure

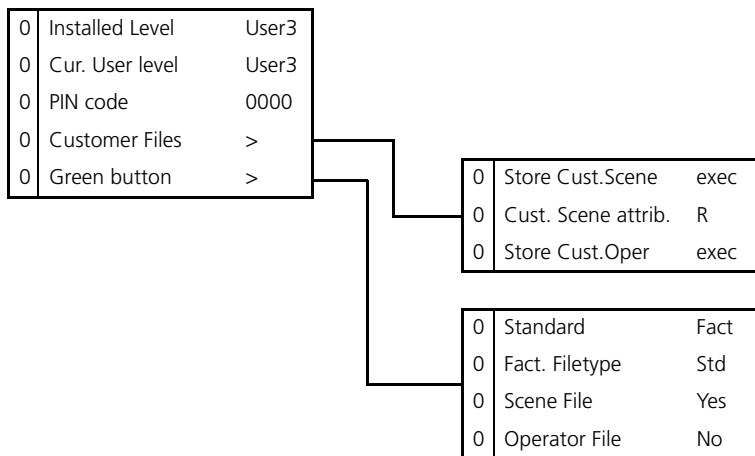

6.1.8 Diagnostics menu structure

Refer to the next chapter for the menu contents.

6.1.9 Service menu structure

Refer to the next chapter for the menu contents.

6.2 Menu contents

The number (0, 1, 2 or 3) in the LEVEL column indicates the user level at which this item is visible in the menu; items with numbers higher than the user level that is set on the camera are not visible in the menu. For example, if user level 2 is set, items marked with a 3 are not visible.

- If an item is not relevant it is not visible in the menu.
- The Scene in the FILE column indicates that the value of this item is stored in the Scene file; the Op. indicates that the value of this item is stored in the Operator file.
- In the VALUES column, the default value of the item is shown in **bold**.



Note

The items available in the camera menu depend on the version of the software loaded in your camera. The software version used to reproduce the menu items in this manual may differ from that of your camera.

6.2.1 VF menu

VF menu (user 0)	Value(s)	Description	Level	File
VF Monitoring	Y, R, G, B, -G, R-G, B-G	Selects type of signal to view in viewfinder.	User 2	Oper
VF detail			User 0	
VF detail	Off, On , Boost	Turns detail for viewfinder signal on or off. Set to Boost to add extra detail to the viewfinder signal.	User 0	Oper
Level	0..99 (50)	Sets detail level for viewfinder signal.	User 0	Oper
Focus assist	Off, On	Adds a crawling effect in the focused areas in the viewfinder to assist focussing.	User 0	Oper
Zebra			User 0	
Zebra	Off, On	Turns zebra indication on or off. Zebra is a diagonal line pattern that indicates that the area affected has risen above a predetermined level of the full scale video exposure value.	User 0	Oper
Zebra Mode	Level, Band	Selects zebra mode: Level = zebra indication appears in areas are brighter than the set level; Band = zebra indication appears in a 2.5% band around the set level.	User 3	Oper
Zebra Level (%)	0..117 (90)	Sets the exposure level at which zebra indication is shown. When level is higher than 100% the zebra indicates overexposed areas.	User 3	Oper
Zebra Contrast	0..99 (15)	Sets the zebra indication contrast.	User 3	Oper
Center Cross	Off, On	Turns the centre marker on or off.	User 0	Oper
QoS bar	Off, On	Turns Quality of Service bar on or off (only available when Wireless adapter is used).	User 0	-

VF menu (user 0)	Value(s)	Description	Level	File
Iris ind.	Off, On	Turns the iris indicator in the viewfinder on or off. This indicator shows the F - stop value of the iris opening of the lens.	User 0	-
Focus ind.	Off, On	Turns the focus indicator in the viewfinder on or off. This indicator shows the focus distance of the lens: 0 = close-up; 99 = infinity.	User 0	-
Zoom ind.	Off, On	Turns the zoom indicator in the viewfinder on or off (if supported by the lens). This indicator shows the zoom range of the lens: 0 = wide angle; 99 = tele.	User 0	-
Box downright	Off, Fltr	Selects information displayed at the bottom right of the viewfinder: Off = indicator is not shown; Fltr = selected optical filter is shown.	User 0	Oper
Safe area	Off, On	Turns the safe area marker on or off. This marks the screen area that represents 80% of the whole viewfinder picture.	User 0	Oper
Safe area type	16:9, 15:9, 14:9, 4:3	Selects the aspect ratio of the safe area marker.	User 0	Oper
Marker	Off, On	Turns the cadre marker on or off.	User 0	Oper
Marker type	15:9, 14:9, 4:3	Sets the aspect ratio of the cadre marker.	User 0	Oper
Marker style	Dot, Shad, Both	Sets the style of the cadre marker: Dot = dotted lines; Shad = shaded areas; Both = dotted lines and shaded areas.	User 0	Oper
Marker shading	Shad, Black	Sets shading style for the cadre marker (when cadre marker style is set to Shad or Both): Shading = transparent area; Black = black area.	User 0	Oper
Ind. white	0..99 (70)	Sets the white level of the characters: 0 = low intensity; 99 = high intensity.	User 2	Oper
Ind. black	0..99 (30)	Sets the black (shading) level of the characters: 0 = black; 99 = no shading.	User 2	Oper
Display	On, Time	Selects the menu display to be permanently on or to disappear after a set time.	User 2	Oper
Menu time	3..30 (10)	Sets the length of time the menu is displayed when the OSD mode is set to Time.	User 3	Oper
Rotary Speed	1..10 (5)	Adjust the sensitivity of the rotary control wheel.	User 3	Oper
Notch EXT	Off, On	Turns external notch filter on or off.	User 0	-
EXT AspectRatio	16:9, 4:3	Aspect ratio converter for external video displayed in the viewfinder.	User 0	Oper

6.2.2 Lens menu

Lens menu (0)	Value(s)	Description	Level	File
Lens type	Std, WA	Select a standard (Std) or wide angle (WA) type lens. This settings affects white shading compensation.	User 0	Oper
Autolris	Off, On	Turns auto iris on or off.	User 0	-
Peak/Average	0..99 (64)	Sets the balance between peak and average video level.	User 3	Scene
Autolris SetPoint	0..99 (35)	Sets auto iris exposure level.	User 3	Scene
Mom.Iris SetPoint	0..99 (50)	Sets momentary iris setpoint level.	User 3	-
RE Iris Comp	Off, On	Turns the iris compensation on or off. Use this setting to compensate for iris loss when a range extender is used.	User 0	-
Autolris Const			User 3	
Autolris Gain	5..10 (5)	Sets auto iris response speed: Lower values give slower speeds.	User 3	-
Ext.Iris Const			User 3	
Gain Speed	1..20 (5)	Sets the gain speed for extended auto iris.	Serv 1	
ExpTime Speed	1..20 (4)	Sets the exposure time speed for extended auto iris.	Serv 1	-
Min. Iris	F5.6, F8.0, F11.0, F16.0	Sets the minimum iris value for extended auto iris.	User 3	-
Max. Iris	F1.4, F2.0 , F2.8, F4.0, F5.6	Sets the maximum iris value for extended auto iris.	User 3	-
Min. ExpTime	1/100, 1/200, 1/500	Sets the minimum exposure time value for extended auto iris.	User 3	-
Max. Gain (dB)	0..15 (15)	Sets the maximum gain value for extended auto iris.	User 3	-
Handgrip Zoom	Off, On	Enables or disables the zoom control on top of the camera carrying handle.	User 0	Oper
Zoom speed	1..10 (5)	Selects the zoom control speed.	User 3	Oper
Zoom curve	0..3 (0)	Selects the zoom reaction curve.	User 3	Oper
Zoom/Focus	Loc, Rem		User 0	-
Lens I/F	Analog, Digital	Select an analog or digital lens interface.	User 0	-
Lens I/F State	OK, NotOK	Displays the status of the lens interface (when a digital lens interface is used).	User 0	-

6.2.3 Video menu

Video menu (user 2)	Value(s)	Description	Level	File
Colour temp			User 2	
Colour Filter	0..99 (50)	This electronic colour filter varies the colour balance to obtain warmer or colder effects for the auto-white memory positions. It resets to 50 when the next automatic white balance process is carried out.	User 2	-
Col. Temp Level	2000..21000 (3200)	Shows current variable colour temperature.	User 2	Scene
Detail			User 2	
Detail	Off, On	Turns detail enhancement on or off.	Serv 1	Scene
Level	0..99 (30)	Sets detail enhancement level.	User 2	Scene
Source Select	R+G, R, G, Y	Selects the source to be used for detail generation.	User 3	Scene
<more>				
Vert Detail	0..99 (50)	Sets the level of the vertical component in the detail signal.	User 3	Scene
Coarse/Fine	0..99 (5)	Sets the coarseness of the detail enhancement (0 = very fine).	User 3	Scene
Level	0..99 (30)	Sets detail enhancement level.	Serv 1	Scene
Level dep	0..99 (40)	Sets dependency level for the noise slicer.	Serv 1	Scene
Noise Slicer	0..99 (10)	Sets the level of the noise slicer.	Serv 1	Scene
Soft Detail			User 2	
Soft Detail	Off, On	Turns soft detail on or off. This function reduces the amount of detail added for large transitions.	User 2	Scene
Level	0..99 (70)	Sets the upper limit level of detail enhancement for soft detail.	User 2	Scene
Knee Detail	Off, 1, 2, 3, 4	Selects a level of detail enhancement for the compressed signal above the knee.	User 3	Scene
Skin			User 2	
Skin	Off, 1, 2, 1+2	Turns skin detail off or on and selects the memory position. Use skin detail to change the detail level within a selected colour range.	User 2	Scene
Auto Skin	Off, On	Turns auto skin detail mode on or off.	User 2	-
View	Off, On	Select on to view the selected area.	User 2	Oper
Skin Level	0..99 (50)	Sets skin detail level	User 2	Scene
<more>				
Width1 Red	0..99 (50)	Sets width level for skin gate 1 (red)	User 3	Scene
Width1 Blue	0..99 (50)	Sets width level for skin gate 1 (blue)	User 3	Scene
Color1 Red	0..99 (50)	Sets color level for skin gate 1 (red)	User 3	Scene
Color1 Blue	0..99 (50)	Sets color level for skin gate 1 (blue)	User 3	Scene

Video menu (user 2)		Value(s)	Description	Level	File
	Width2 Red	0..99 (50)	Sets width level for skin gate 2 (red)	User 3	Scene
	Width2 Blue	0..99 (50)	Sets width level for skin gate 2 (blue)	User 3	Scene
	Color2 Red	0..99 (50)	Sets color level for skin gate 2 (red)	User 3	Scene
	Color2 Blue	0..99 (50)	Sets color level for skin gate 2 (blue)	User 3	Scene
Flare				Serv 1	
	Flare	Off, On	Turns flare compensation on or off.	Serv 1	Scene
	Red	0..99 (10)	Sets flare compensation level (red).	Serv 1	Scene
	Green	0..99 (15)	Sets flare compensation level (green).	Serv 1	Scene
	Blue	0..99 (25)	Sets flare compensation level (blue).	Serv 1	Scene
Black				User 2	
	Blackstretch	0..99 (50)	Sets black stretch level. When level is 50 there is no stretch, values higher than 50 represent black press.	User 3	Scene
	Master	0..99 (50)	Sets black level (master).	User 2	Scene
	<more>				
	Red	0..99 (50)	Sets black level (red).	User 3	Scene
	Green	0..99 (50)	Sets black level (green).	User 3	Scene
	Blue	0..99 (50)	Sets black level (blue).	User 3	Scene
	Master	0..99 (50)	Sets black level (master).	User 3	Scene
Gain				User 2	
	Red	0..99 (50)	Sets gain level (red).	User 2	Scene
	Green	0..99 (50)	Sets gain level (gree).	User 2	Scene
	Blue	0..99 (50)	Sets gain level (blue).	User 2	Scene
	Range	3dB, 6dB	Selects gain control step size.	User 2	Scene
	Mastergain (dB)	<xx dB>	Displays the current gain in dB.	User 2	Scene
Knee				User 2	
	Knee	Off, Var, Auto	Sets knee mode: Auto = automatic; Var = variable (manual); Off = no knee function.	User 2	Scene
	Knee Type	Y, NAM	Selects knee type: Y = luminance; NAM = luminance of highest RGB component.	User 3	Scene
	Slope M	0..99 (50)	Sets the slope of the knee gamma curve (when knee mode = Var).	User 3	Scene
	Point M	0..99 (60)	Sets the point where the knee gamma curve begins (when knee mode = Var).	User 3	Scene
	<more>			Serv 1	
	Knee Limit	0..99 (99)	Selects the level above which the knee limiter is active.	Serv 1	Scene
	Desat	Off, On	Turns knee desaturation on or off.	Serv 1	Scene

Video menu (user 2)		Value(s)	Description	Level	File
	Desat Level	0..99 (50)	Sets the desaturation level (when knee mode is Var and Desat is On)	Serv 1	Scene
	Auto Point	0..30 (30)	Sets the point where the knee gamma curve begins (when knee mode is Auto).	Serv 1	Scene
	Auto Ref	0..99 (30)	Sets the slope of the knee gamma curve (when knee mode is Auto).	Serv 1	Scene
Gamma				User 2	
	Curve	BBC04, BBC05, BBC06, ARD, 6xARD, RAI, CCIR, 709-J, 709-S	Selects a standard curve for gamma correction.	User 3	Scene
	Preset	1, 2, Lin, Var	Selects gamma preset: 1 = Nominal curve; 2 = Low curve; Lin = Linearised curve; Var= variable (manual) curve.	User 2	Scene
	Master	0..99 (76)	Sets gamma level (master).	User 3	Scene
	Red	0..99 (76)	Sets gamma level (red).	User 3	Scene
	Green	0..99 (76)	Sets gamma level (green).	User 3	Scene
	Blue	0..99 (76)	Sets gamma level (blue).	User 3	Scene
Matrix				User 2	
	Matrix	EBU, Skin, B/W, RAI, BBC, 1:1, CoolFL, Var1, Var2	Selects a preset for color matrix: EBU = true color matrix; Skin = optimised for skin tone reproduction; B/W: monochrome picture; RAI: Sony cameras reproduction; BBC = BBC optimisation; 1:1 = matrix is off; CoolFL= optimised for mixed fluorescent and incandescent lighting. Var1 = variable setting 1; Var2 = variable settings 2;	User 3	Scene
	Saturation	0..99 (50)	Sets saturation level for color matrix.	User 2	Scene
	R>G	0..99 (50)	Sets the red to green ratio.	Serv 1	Scene
	G>R	0..99 (50)	Sets the green to red ratio.	Serv 1	Scene
	R>B	0..99 (50)	Sets the red to blue ratio.	Serv 1	Scene
	B>R	0..99 (50)	Sets the blue to red ratio.	Serv 1	Scene
	G>B	0..99 (50)	Sets the green to blue ratio.	Serv 1	Scene
	B>G	0..99 (50)	Sets the blue to green ratio.	Serv 1	Scene
	Mat/Gam	G/M, M/G	Selects the order of the matrix and gamma functions: G/M = first gamma correction, then matrix; M/G = first matrix, then gamma correction.	Serv 1	Scene
White limiter				Serv 1	
	White limit	Off, On	Turns white limiter on or off. Use to limit highlight levels in the video signal.	Serv 1	Scene

Video menu (user 2)		Value(s)	Description	Level	File
	Master	0..99 (80)	Sets the white limiter level. This is the luminance level at which white limiting occurs.	Serv 1	Scene
Shading				Serv 1	
	White shading	Off, On	Turns the white shading compensation on or off.	Serv 1	-
	HSawRed	0..99 (50)	Sets the horizontal sawtooth value (red).	Serv 1	-
	HSawGreen	0..99 (50)	Sets the horizontal sawtooth value (green).	Serv 1	-
	HSawBlue	0..99 (50)	Sets the horizontal sawtooth value (blue).	Serv 1	-
	VSawRed	0..99 (50)	Sets the vertical sawtooth value (red).	Serv 1	-
	VSawGreen	0..99 (50)	Sets the vertical sawtooth value (green).	Serv 1	-
	VSawBlue	0..99 (50)	Sets the vertical sawtooth value (blue).	Serv 1	-
	HParRed	0..99 (0)	Sets the horizontal parameter (red).	Serv 1	-
	HParGreen	0..99 (0)	Sets the horizontal parameter (green).	Serv 1	-
	HParBlue	0..99 (0)	Sets the horizontal parameter (blue).	Serv 1	-
	VParRed	0..99 (0)	Sets the vertical parameter (red).	Serv 1	-
	VParGreen	0..99 (0)	Sets the vertical parameter (green).	Serv 1	-
	VParBlue	0..99 (0)	Sets the vertical parameter (blue).	Serv 1	-
	Freeze	Off, On	Turns image freeze on or off. Use to assist setup and configuration of the camera.	User 2	-

6.2.4 Install menu

Install (user 0)	Value(s)	Description	Level	File
Video mode	< available modes >	Selects a video acquisition mode (available modes depend on your camera version).	User 3	-
Disable Camera	Off, On	Turn disable camera function on or off. When on, the camera's user panel is locked.	User 0	-
Intercom			User 1	
SideTone Level	0..99 (50)	Sets the sidetone level (audio feedback to the headphone) in the camera operator's headphone.	User 3	Oper
Cam Mic	Off, Switch , Track, Prod	Selects the camera operator's intercom mic routing: Off = no routing; Switch = intercom route depends on switch at the rear of the adapter; Track = route signal to tracker channel; Prod = route signal to production channel.	User 1	Oper
Cam Mic Gain	0dB, 40dB	Selects gain of camera operator's intercom mic.	User 1	Oper
Cam Mic Power	Off, On	Turns +48V phantom power to camera operator's intercom mic on or off.	User 1	Oper
Prod volume	Front , Rear	Selects volume control used to adjust Production channel volume.	User 1	Oper
Cam PROD	Off, Left, Right, Both	Selects the camera operator's ear muff(s) for the production channel.	User 1	Oper
Cam ENG	Off, Left, Right, Both	Selects the camera operator's ear muff(s) for the engineering channel.	User 1	Oper
Cam PROG	Off, Left, Right, Both	Selects the camera operator's ear muff(s) for the program channel.	User 1	Oper
Cam TRACK	Off, Left, Right, Both	Selects the camera operator's ear muff(s) for the tracker channel.	User 1	Oper
Cam TRACK Level	0..99 (50)	Sets tracker signal level in the camera operator's headphones.	User 1	Oper
Track Mic To	Off, Cam, Eng, Prod, All	Selects the tracker mic routing.	User 1	Oper
Track Mic Gain	0dB, 40dB	Selects gain of camera operator's intercom mic.	User 1	Oper
Track Mic Power	Off, On	Turns +48V phantom power to tracker's mic on or off.	User 1	Oper
Track Source	Eng, Side	Selects engineering intercom or tracker's mic sidetone for tracker's headphone.	User 1	Oper
Audio			User 1	
Audio ip mode	Ch1, Ch1&2	Selects audio input mode: Channel 1 or Channel 1 and 2.	User 1	Oper
Audio Gain Mode	Loc, Ext	Selects audio gain mode: Local: set audio gain level in the camera; Ext: audio gain level is controlled by the base station (external).	User 1	Oper
Audio 1 Source	Line, Mic, Mic48, Front	Selects source for audio channel 1.	User 1	Oper

Install (user 0)		Value(s)	Description	Level	File
	Audio 1 Level	-22dB, -28dB, -34dB, -40dB, -46dB, -52dB, -58dB, -64dB	Sets input gain level for audio channel 1 (when audio gain mode is set to local).	User 1	Oper
	Audio 1 HPF	Off, On	Turns high-pass filter for audio channel 1 on or off. Use to reduce 50Hz hum or low frequency noise.	User 1	Oper
	Audio 2 Source	Line, Mic, Mic48, Front	Selects source for audio channel 2.	User 1	Oper
	Audio 2 Level	-22dB, -28dB, -34dB, -40dB, -46dB, -52dB, -58dB, -64dB	Sets input gain level for audio channel 2 (when audio gain mode is set to local).	User 1	Oper
	Audio 2 HPF	Off, On	Turns high-pass filter for audio channel 2 on or off. Use to reduce 50Hz hum or low frequency noise.	User 1	Oper
Tally				User 0	
	Onair Lamp	Enable, Disable	Select disable when the tally light at the front of the 7" viewfinder have to follow the tally signal; select disable if you never want it to light.	User 0	Oper
	Tally Lock	Off, On	Turns tally lock function on or off. When tally lock is on, some camera controls are locked when camera is on air.	User 3	-
Reverse Scan				User 0	
	Reverse Scan	Off, On	Turns reverse scan on or off. Reverse scan flips the image and can be used when the camera is mounted at a rotated angle.	User 0	Scene
	Mode	Horiz, Vert, Both	Selects reverse scan mode: Horiz = the image is flipped horizontally; Vert = the image is flipped vertically; Both = the image is flipped both horizontally and vertically.	User 0	Scene
Exposure					
	Lighting	-10..+10 (0)	Sets the exposure correction to synchronise with ambient lighting frequency when exposure mode is 50 Hz or 60 Hz (not available in high speed video modes).	User 1	Scene
Clean Scan				User 1	-
	Cl.Scan Mode	Extended, Normal	Selects clean scan mode: Normal = shutter is running (no smear); Extended = shutter is not running (more accurate clean scan but possible vertical smear).	User 1	-
	Value	50.6.. 103.1 Hz (50 Hz) 54.7 .. 121.5 Hz (60 Hz) 122.0 .. 200.0 Hz (high speed modes)	Select clean scan frequency.	User 1	-
	Units	Hz, mSec	Selects display units for clean scan.	User 1	-
Gain Preset				User 2	
	Gain - (dB)	-3dB , -6dB	Selects gain value for - preset.	User 2	Oper
	Gain + (dB)	3dB , 6dB, 9dB	Selects gain value for + preset.	User 2	Oper

Install (user 0)		Value(s)	Description	Level	File
	Gain ++ (dB)	6dB, 9dB, 12dB	Selects gain value for ++ preset.	User 2	Oper
	Gain +++ (dB)	12dB, 15dB, 18dB	Selects gain value for +++ preset.	Serv 1	Oper
AutoWhite				Serv 1	
	Awb Speed	0..99 (4)	Sets the speed for the auto white balance procedure.	Serv 1	-
	Awb Gain	0..99 (10)	Sets the gain value for the auto white balance procedure.	Serv 1	-
Timing				User 0	
	H.Phase	0..99 (50)	Sets the horizontal phase for the CVBS output signal.	User 0	-
	V-Shift	Off, On	Turns V-Shift on or off. Used to synchronize the camera with DLP type projectors or to hide the horizontal bar of CRT monitors. Only available for a limited number of video modes.	User 0	Scene
	V-Shift Level	0..99 (0)	Sets the variable video delay from 0 to 1 frame.	User 0	Scene
Private Data		Off, C->B, B->C, B<>C	Selects the use of the tracker intercom channel: Off = used for tracker microphone signal; C->B = private data from cam to bs; B->C = private data from bs to cam; B<>C = private data between bs and cam.	User 0	Oper
PCI id		0..8 (1)	Selects id for external PC operation.	Serv 1	-
Buttons					
	SW1	Call, EXT1, EXT2	Assigns a function to Switch 1: Call = activate call signal; EXT1 = switch to external signal 1; EXT2 = switch to external signal 2.	User 0	Oper
	SW1 Control	Mom., Alt.	Selects behaviour of Switch 1: momentary or alternating.	User 0	Oper
	SW2	Elris, FocAst, EXT1, EXT2	Assigns a function to Switch 2: Elris = Turns extended auto iris on or off; FocAst = Turns focus assist on or off; EXT1 = switch to external signal 1; EXT2 = switch to external signal 2.	User 0	Oper
	SW2 Control	Mom., Alt.	Selects behaviour of Switch 2: momentary or alternating.	User 0	Oper
	VTR Start	PROD, ENG, Zoom, EXT1, EXT2	Assigns a function to VTR Start switch: PROD = Production intercom; ENG = Engineering intercom; Zoom = Viewfinder zoom function; EXT1 = switch to external signal 1; EXT2 = switch to external signal 2.	User 1	Oper
	VTR St. Control	Mom., Alt.	Selects behaviour of VTR Start switch: momentary or alternating.	User 1	Oper

Install (user 0)	Value(s)	Description	Level	File
VTR Lens	PROD, ENG , Zoom, EXT1, EXT2	Assigns a function to VTR Lens switch: PROD = Production intercom; ENG = Engineering intercom; Zoom = Viewfinder zoom function; EXT1 = switch to external signal 1; EXT2 = switch to external signal 2.	User 1	Oper
VTR L. Control	Mom., Alt.	Selects behaviour of VTR Lens switch: momentary or alternating.	User 1	Oper
RET Lens	Zoom, EXT	Assigns a function to RET Lens switch: Zoom = Viewfinder zoom function; EXT = switch to external signal (select source with switch at the rear of the camera);	User 1	Oper
RET Control	Mom., Alt.	Selects behaviour of RET Lens switch: momentary or alternating.	User 1	Oper
RET2 Switch	Zoom, EXT	Assigns a function to RET Lens switch: Zoom = Viewfinder zoom function; EXT = switch to external signal (select source with switch at the rear of the camera);	User 1	Oper
RET2 Control	Mom., Alt.	Selects behaviour of RET2 Lens switch: momentary or alternating.	User 1	Oper
Handgrip Left	PROD, ENG	Selects channel to use with the left button under the handgrip.	User 1	Oper
Fan Operation			User 3	
Head Fan	Off, On	Turns the head fan on or off. Turns itself on after 120 min. or when temperature is too high.	User 3	-
Adapter Fan	Off, On	Turns the head fan on or off. Turns itself on after 120 min. or when temperature is too high.	User 3	-

6.2.5 Files menu

Files menu (user 1)	Value(s)	Description	Level	File
Store scenefile				
FileSelect	Standard, SCam1..4, SCard1..20, <new file>	Selects a standard, camera-stored or card-stored scenefile to be restored.	User 2	-
Store	exec	Stores the current scene settings in the selected scenefile.	User 2	-
Recall scenefile				
FileSelect	Standard, SCam1..4, SCard1..20, <new file>	Selects a standard, camera-stored or card-stored scenefile to recall.	User 1	-
Recall	exec	Recalls the selected scenefile to the camera. Overwrites current oper. settings.	User 1	-
Store oper.file				
FileSelect	Standard, OCam1..4, OCard1..20, <new file>	Selects a standard, camera-stored or card-stored operator file to be restored.	User 1	-
Store	exec	Stores the current scene settings in the selected operator file.	User 1	-
Recall oper.file				
FileSelect	Standard, OCam1..4, OCard1..20, <new file>	Selects a standard, camera-stored or card-stored operator file to recall.	User 1	-
Recall	exec	Recalls the selected operator file to the camera. Overwrites current oper. settings.	User 1	-
Attributes				
FileSelect	<available files>	Selects a file to change its attributes.	User 2	-
FileName	<file name>	Displays the selected file name.	User 2	-
Attribute	R/W, R	Selects the attribute for the selected file: R/W = Read and write; R = Read only.	User 2	-
Card				
Name	<card name>	Displays the card name.	User 2	-
Type	None, Storage, Owner, Serv 1, Serv 2, Unknown	Displays the type of inserted card.	User 2	-
Free (%)	0..99 (0)	Displays free space left on the card.	User 2	-
Num Files	0..255 (0)	Displays number of files on the card.	User 2	-
Card Attr				
Cardname	<card name>	Changes name of the card.	User 2	-
Format card	exec	Format card.	User 3	-
Files				
Select	SCard1..SCard2, OCard1..OCard10	Selects a file on the card.	User 2	-
Delete	exec	Deletes the selected file.	User 2	-
Filename	<name>	Changes name of the selected file.	User 2	-
Attribute	R/W, R	Sets file attribute of the selected file.	User 2	-

6.2.6 Security menu

Security menu (user 0)	Value(s)	Description	Level	File
Installed level	User 0, User 1, User 2, User 3	Selects the user level.	User 0	-
Cur. user level	No Oper, User 0, User 1, User 2, User 3, Serv 1	Displays the current user level.	User 0	-
PIN Code	**** (0000)	Enter four digit PIN code to enable access to the Serv 1 level.	User 0	-
Customer files			User 0	
Store Cust. Scene	exec	Stores the current scene settings in the customer scenefile.	User 0	-
Cust. Scene attrib.	R/W, R	Selects the attribute for the customer scene file: R/W = Read and write; R = Read only.	User 0	-
Store Cust. Oper	exec	Stores the current operator settings in the customer operator file.	User 0	-
Green button			User 0	
Standard	Fact, Cust	Selects file to be recalled when the green button is pressed: Fact = factory defaults; Cust = Customer file;	User 0	-
Fact. Filetype	Std, 8000	Selects type of factory default file to use: Std = standard factory defaults; 8000 = LDK 8000 factory defaults.	User 0	-
Scene file	Yes, No		User 0	-
Operator file	Yes, No		User 0	-

6.2.7 Diagnostics menu

Diagnostics menu (user 2)		Value(s)	Description	Level	File
Communication				User 2	
	BS Connected	Yes, No	Displays base station connection status.	User 2	-
	C2IP Panels	0..99	Displays amount of C2IP control panels connected to the camera.	User 2	-
	DTCP			User 3	
	Packets Recv	0..65535	Displays received packets.	User 3	-
	Packets Sent	0..65535	Displays sent packets.	User 3	-
	Frame Errors	0..65535	Displays frame errors.	User 3	-
	Checksum Errors	0..65535	Displays checksum errors.	User 3	-
	Cam. Config	INVALID, 4000MK2, 5000, 6000, 6200, 8000, SportCam	Displays camera system configuration.	User 2	-
	Camera ID	<id>	Displays camera identification code.	User 2	-
	Camera Number	0..99	Displays logical camera number in the network.	User 2	-
	Adaptor type	None, Triax, Fiber, Wireless, NonTriax	Displays type of the attached camera adaptor.	User 2	-
	Sensor Voltage	OK, NotOK	Displays sensor voltage status.	User 2	-
	Shutter Run	Run, Off	Displays shutter run status.	User 2	-
	Front Power	OK, NotOK	Displays front (imager) power status.	User 2	-
	Y Carrier	OK, NotOK	Displays Y carrier status.	User 2	-
	Cam. 12NC	####	Displays last 4 digits of the camera 12NC.	User 2	-
	Cam. Version	<version>	Displays camera version.	Serv 1	-
	Cam. Status	0..99	Displays camera status.	User 2	-
	Adap. 12NC	####	Displays last 4 digits of the adapter 12NC.	User 2	-
	Adap. Version	<version>	Displays adapter version.	Serv 1	-
	Adap. Status	0..99	Displays adapter status.	User 2	-
	Cam. Temp			User 2	-
	Head temp C	-55..128	Displays camera head temperature in C.	User 2	-
	Head temp F	-67..262	Displays camera head temperature in F.	User 2	-
	Head fan	Off, Low, Med, High, Max	Displays camera head fan status.	User 2	-
	Adaptor temp C	-55..128	Displays adapter temperature in C.	User 2	-
	Adaptor temp F	-67..262	Displays adapter temperature in F.	User 2	-
	Adaptor fan	Off, Low, Med, High, Max	Displays adapter fan status.	User 2	-
	PCB Status			User 2	
	Board	DVP, SyncM, PPG, PPGsb, SeDa, LSP, RCB, PrePr, FSP, DaCam, FrDri, DacOu, FwDri, Front	Selects a board to display detailed information.	User 2	

Diagnostics menu (user 2)		Value(s)	Description	Level	File
	Board PID	<id>	Displays Product Identification Code of the selected board.	User 2	
	Board 12NC	####	Displays the last 4 digits of the 12NC of the selected board.	User 2	
	Board Status	0..99	Displays the hardware status of the selected board.	User 2	
	BootSw Ver.	0..99	Displays the boot software version of the selected board.	User 2	
	FPGA Ver.	0..99	Displays the FPGA version of the selected board.	User 2	
	Firmw 12NC	####	Displays the last 4 digits of the firmware 12NC of the selected board.	User 2	
	Firmw Status	0..99	Displays the firmware status of the selected board.	User 2	
	Firmw Version	0..99	Displays the firmware version of the selected board.	Serv 1	
	Softw 12NC	####	Displays the last 4 digits of the 12NC of the selected board.	User 2	
	Softw Status	0..99	Displays the software status of the selected board.	User 2	
	Softw Version	0..99	Displays the software version of the selected board.	Serv 1	
System Status				User 2	
	System	Unknown, HD, HD-HS, SD, Illegal	Displays the system configuration.	User 2	
	Camera	Unknown, HD, HD-HS, SD, Illegal	Displays the camera configuration.	User 2	
	Head HW	Unknown, HD, HD-HS, SD, Illegal	Displays the camera head hardware configuration.	User 2	
	Adaptor	Unknown, HD, HD-HS, SD, Illegal	Displays the adaptor configuration.	User 2	
	Basestation	Unknown, HD, HD-HS, SD, Illegal	Displays the base station configuration.	User 2	

6.2.8 Service menu

Service menu (user 3)	Value(s)	Description	Level	File
Test Signal			User 3	
Test Signal	Off, On	Turns video test signal on or off.	User 3	-
Test Input	DacO, DVP	Selects test input.	Serv 1	-
Test Select	SawT, Step	Selects test waveform type.	User 3	-
Test Select	SawT, Bars	Selects test waveform type.	Serv 1	-
Encoder colourbar	Off, On	Turns encoder colour bar on or off	User 3	-
LPC	Off, On	Turns Leaking Pixel Correction on or off.	Serv 1	-
BPC	Off, On	Turns Black Pixel Correction on or off.	Serv 1	-
Calibrations			Serv 1	
3200K	Off, On	Runs 3200K calibration procedure.	Serv 1	-
3200K Reset	Fact, Cust	Selects reset mode for 3200K calibration.	Serv 1	-
H-Phase Front	0..255 (128)	Sets horizontal phase for front.	Serv 1	-
Scaler			User 0	
Encoder	Off, On	Turns encoder for scaler on or off.	User 3	-
Chroma	Off, On	Turns chroma for scaler on or off.	User 0	-

Chapter 7

Connectors

7.1 Camera connectors

Figure 7-1. Camera connector location

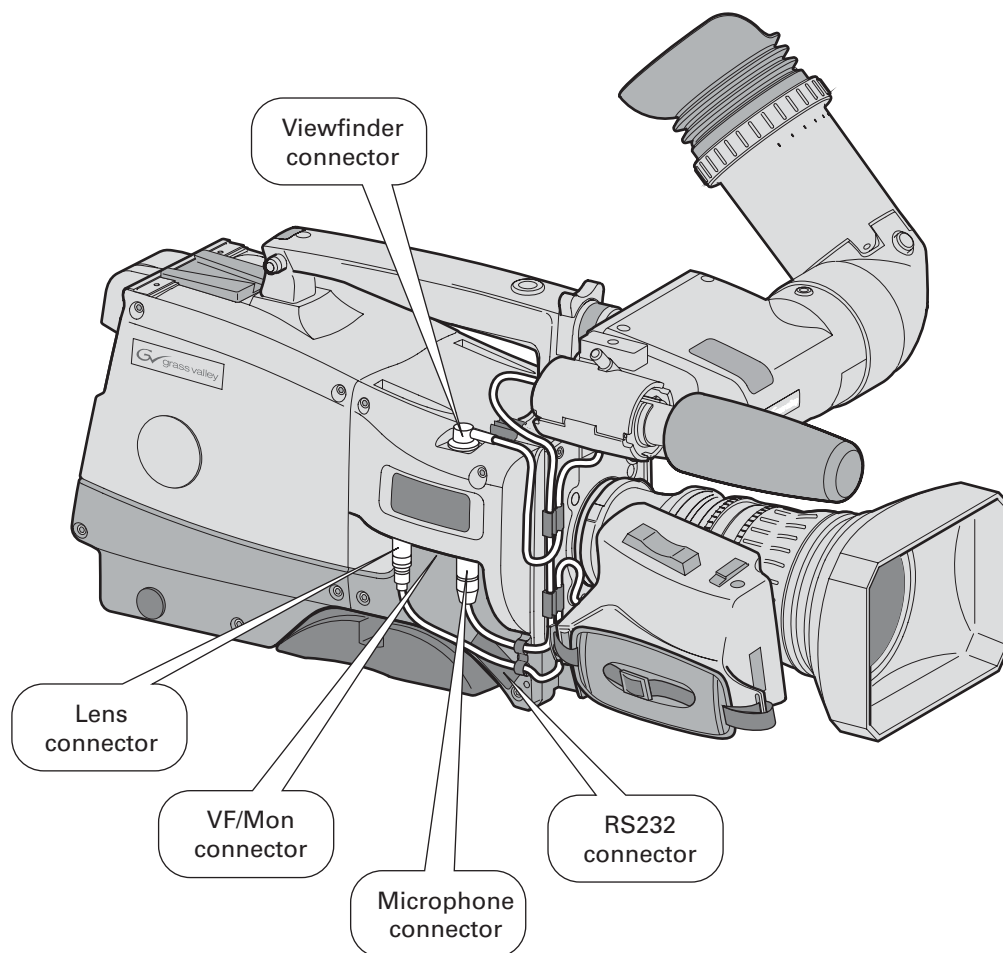

7.1.1 Viewfinder connector

Figure 7-1. Camera viewfinder connector

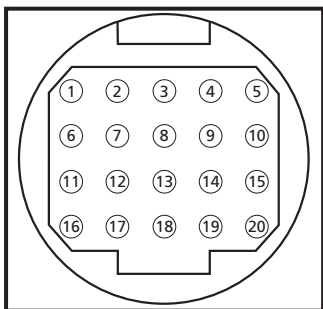

20-pole female; panel view
 Panel part number: 5322 214 12544
 Cable part number (male): 5322 320 12159

- | | |
|----------------------|---------------|
| 1. -80V | 11. GND |
| 2. n.c. | 12. vf video |
| 3. GND | 13. Pb vf ret |
| 4. INTN-D | 14. Pr vf ret |
| 5. vf ext video | 15. GND |
| 6. n.c. | 16. +batt |
| 7. vf video ret | 17. +batt |
| 8. SDA-D | 18. Pb vf |
| 9. SCL-D | 19. Pr vf |
| 10. vf ext video ret | 20. shield |

7.1.2 VF/Mon connector

Figure 7-2. VF/Mon connector

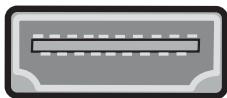

19-pole multimedia interface connector; panel view

- | | |
|-----------------------|-----------------------|
| 1. TDMS Data 2+ | 11. TDMS Clock shield |
| 2. TDMS Data 2 Shield | 12. TDMS clock - |
| 3. TDMS Data 2 - | 13. VF-video (CEC) |
| 4. TDMS Data 1+ | 14. + 12 V (switched) |
| 5. TDMS Data 1 Shield | 15. SCL |
| 6. TDMS Data 1- | 16. SDA |
| 7. TDMS Data 0+ | 17. Ground |
| 8. TDMS Data 0 shield | 18. +5V power |
| 9. TDMS Data 0- | 19. Hot Plug Detect |
| 10. TDMS Clock+ | |

7.1.3 Lens connector

Figure 7-3. Camera lens connector

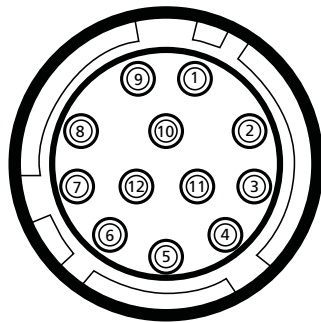

Hirose 12-pole female; panel view
 Panel part number (X15): 5322 265 10389
 Cable part number (male): 5322 265 41208

- | | |
|-----------------------|------------------------|
| 1. Ext. Video On/Off | 8. Lens Servo |
| 2. VTR Trigger Switch | 9. Range Extender |
| 3. -batt | 10. Zoom Follow |
| 4. Momentary Iris | 11. Focus follow* |
| 5. IrisControl | 12. Spare |
| 6. + batt | |
| 7. Iris Follow | * not standard on lens |

7.1.4 Audio microphone connector

Figure 7-4. Audio microphone connector

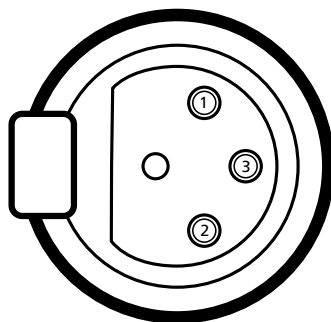

XLR 3-pole female; panel view
 Panel part number (X13): 5322 267 40523

1. Audio Screen
2. Audio In
3. Audio Return

Microphone impedance >200 ohm

Sensitivity range: -70 to -28 dBm

Signal at pin 2 of audio input is in phase with signal at pin 2 of audio output.

7.1.5 RS232 serial connector

Figure 7-5. RS232 serial connector

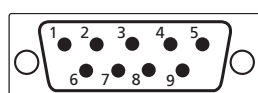

SubD 9-pin male; panel view (X12)

- | | |
|------------|-----------|
| 1. SPARE | 6. RS-DSR |
| 2. RS-RXD | 7. RS-RTS |
| 3. RS-TXD | 8. RS-CTS |
| 4. RS-DTR | 9. +12V |
| 5. RS-DGND | |

7.2 Connectors on the TriaxHD adapter

Figure 7-2. TriaxHD adapter connector location

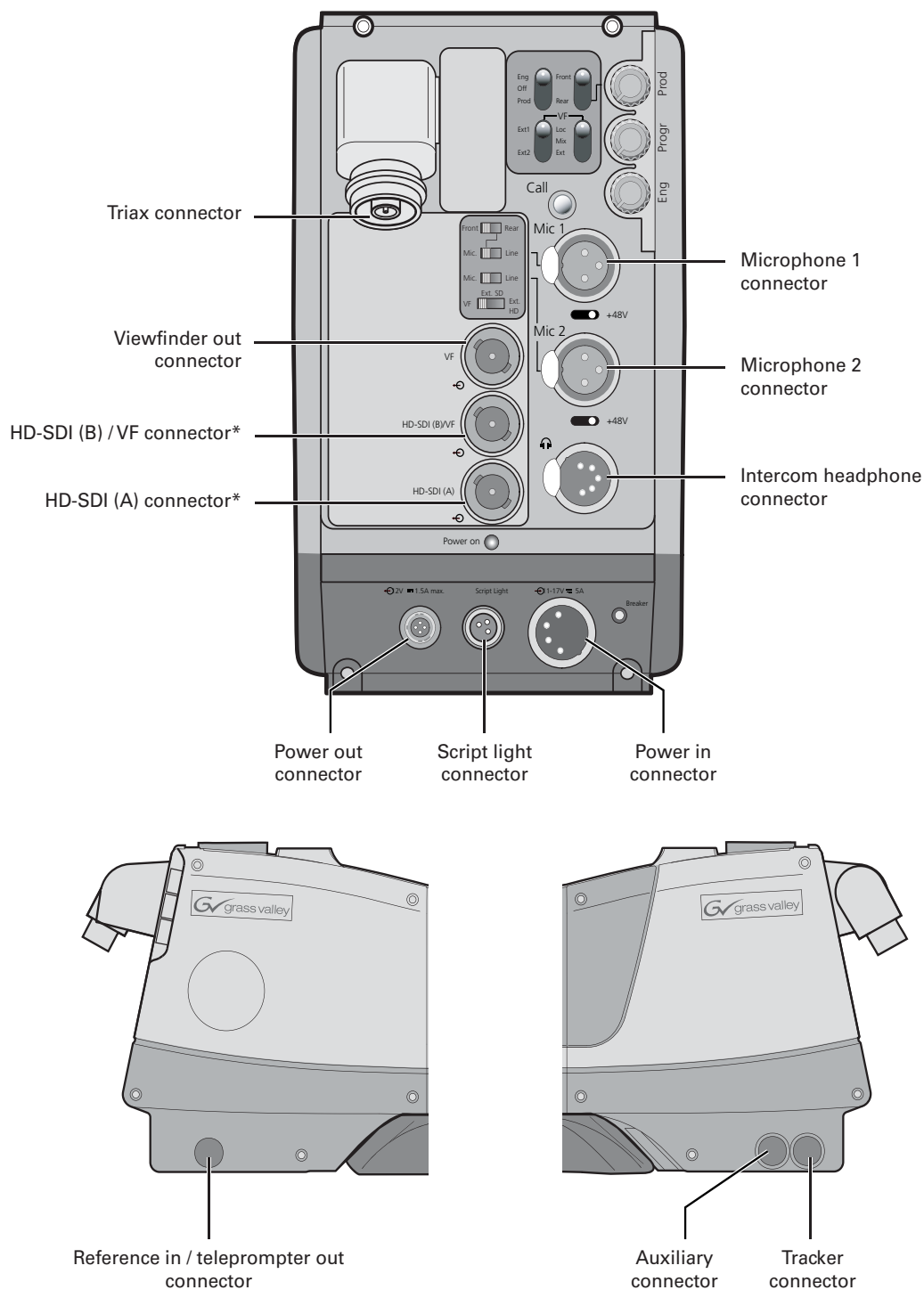

7.2.1 Triax connector

Figure 7-6. Triax connector

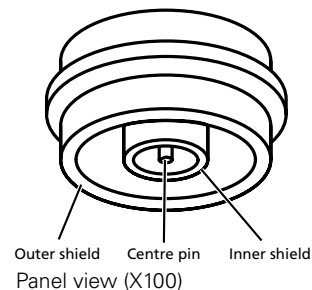

1. Centre pin: Power and signals
2. Inner shield: Return
3. Outer shield: Camera housing GND

Various types of triax connector are available.

7.2.2 Viewfinder / External video output connector

Figure 7-7. Analogue video output connector

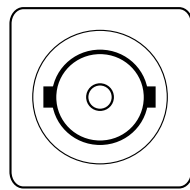

BNC connector: panel view (X107)

This socket provides an analogue 1.0 Vpp output viewfinder signal or an external video signal from the Base Station.

A switch selects either the VF signal (Y-only), an SD external signal (CVBS) or a scaled HD external signal (Y-only).

7.2.3 HD - SDI (B) connector

Figure 7-8. HD - SDI (B) connector

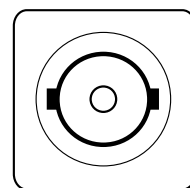

BNC connector: panel view (X106)

This socket provides the HD-SDI output viewfinder signal.

7.2.4 HD - SDI (A) connector

Figure 7-9. HD - SDI (A) connector

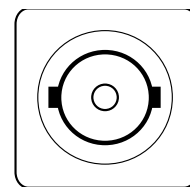

BNC connector: panel view (X105)

This socket is used to output the camera HD-SDI video signal according to SMPTE 292M.

SportCam version

This socket provides the HD-SDI output viewfinder signal.

7.2.5 Audio microphone 1 connector

Figure 7-10. Audio microphone 1 connector

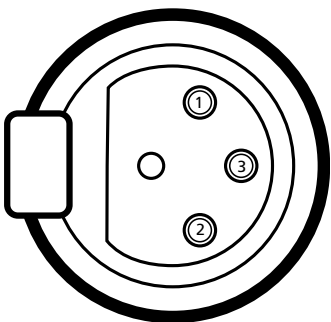

XLR 3-pole female; panel view (X102)

1. Audio Screen
2. Audio In
3. Audio Return

Microphone impedance > 200 ohm
Phantom power +48V switchable
Sensitivity range microphone: -64 to -22 dBu

Sensitivity range line: +10 to +42 dBu

Signal at pin 2 of audio input is in phase with signal at pin 2 of audio output.

7.2.6 Audio microphone 2 connector

Figure 7-11. Audio microphone 2 connector

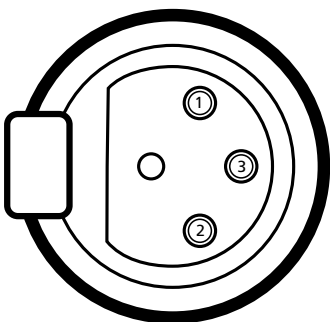

XLR 3-pole female; panel view (X103)

1. Audio Screen
2. Audio In
3. Audio Return

Microphone impedance >200 ohm
Phantom power +48V switchable
Sensitivity range microphone: -64 to -22 dBu

Sensitivity range line: +10 to +42 dBu

Signal at pin 2 of audio input is in phase with signal at pin 2 of audio output.

7.2.7 Intercom headset connector

Figure 7-12. XLR intercom headset connector

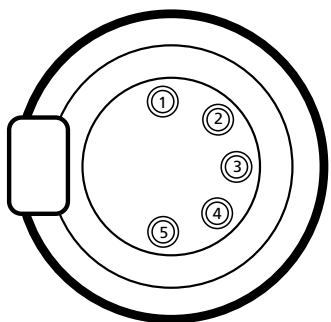

XLR 5-pole female; panel view (X104)

1. Microphone return
2. Microphone
3. Telephone return
4. Telephone left
5. Telephone right

Microphone level: -64 dBu / -24 dBu switchable
Microphone impedance: >600 Ohm

Output level: +6 dBu nominal
Output impedance: <50 Ohm

7.2.8 DC power input socket



Caution

The input voltage must not exceed +17 Vdc.

Figure 7-13. DC power input connector

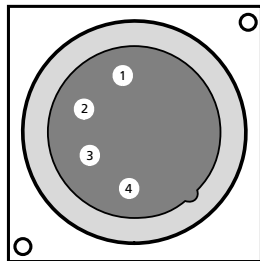

XLR 4-pin male: panel view (X101)

1. Ground
2. Ground (internally bridged to pin 1)
3. +11.5 Vdc . . . +17 Vdc (internally bridged to pin 4)
4. +11.5 Vdc . . . +17 Vdc

This socket accepts a DC voltage of 15V nominal.

7.2.9 DC power and tally output socket

Figure 7-14. DC power and tally output connector

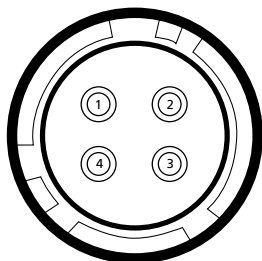

Hirose 4-pole female: panel view (X110)

1. Ground
2. On air
3. No connection
4. +12 Vdc (max. 18W)

Shield of cable directly to the connector housing.

The socket provides access to an internal tally switch. When the camera is on-air, the contact of the internal relay is closed.

7.2.10 Script light power supply socket

Figure 7-15. Script light power supply output connector

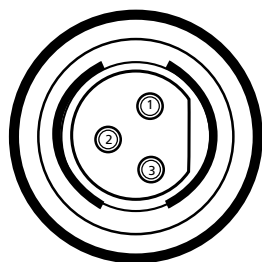

Fischer 3-pole female: panel view (X111)

1. +12 Vdc (maximum dissipation 3W)
2. Power return
3. Shield

7.2.11 Teleprompter output / Reference input connector

Figure 7-16. Teleprompter / Reference connector

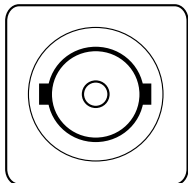

BNC connector: panel view (X112)

Teleprompter output (Triax mode)

This socket supplies the 1.0 Vpp teleprompter signal applied to the Base Station.

Reference input (Local mode)

This connector is used to genlock the camera to a 0.6 Vpp HD tri-level reference input signal.

7.2.12 Tracker communications connector

Figure 7-17. Tracker communications connector

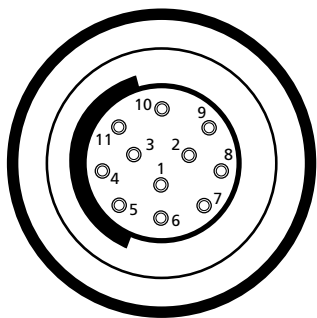

Fischer 11-pole female; panel view
Panel part number (X108): 3922 040 02463

1. On-air signal return
2. Tracker microphone return
3. Tracker microphone input
4. Production tracker
5. Sidetone/engineering tracker
6. Intercom return
7. Program sound tracker
8. Cameraman microphone
9. Tally control tracker (Cmos level, R out = 1k)
10. +12V; I max. = 100mA
11. +12V return

Microphone level: -64dBu/-24dBu switchable
Microphone impedance: >600 ohm

Intercom output level: nom. 0 dBu , max +6 dBu
Intercom output impedance: <200 ohm

7.2.13 Auxiliary connector

Figure 7-18. Auxiliary connector

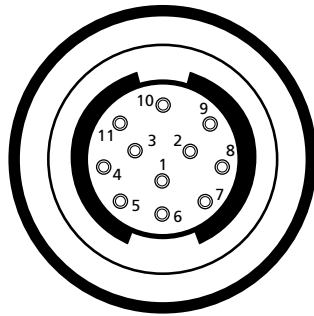

Fischer 11-pole female; panel view
Panel part number (X109): 3922 040 02512

1. +5VL
2. 0VL
3. AN0
4. AN1
5. Spare
6. On-air n.c.
7. Private Data Camera to Base Station
8. Ground
9. Private Data Base Station to Camera
10. Ground
11. Shield

Private data input signals:
 0 <0.8 Volt; 1 >2.4 Volt
 max. level: +/-12 Volt
 input impedance: >100 kOhm
 baud rate: 2400 bits/s nom; 4800 bits/s max.

Private data output signals:
 C-MOS levels 5V
 output impedance: <1 kOhm.

Analogue outputs (AN0 and AN1):
 output level: 0 - 5 Volt
 output impedance: 100 Ohm

Chapter 8

Specifications

8.1 Specifications for LDK 8000

Item	Value
Power requirements	supplied via adapter or local power
Power consumption	60 W (camera head + TriaxHD adapter + viewfinder)
Operating temperatures	-20 to +45°C (-4 to +113°F)
Storage temperatures	-20 to +60°C (-4 to +140°F)
Weight (approx.)	5.0 kg (11 lbs) incl. 2-inch VF and TriaxHD adapter
Pick-up device	3 x 2/3-inch HD-DPM ⁺ CCDs 1080i/720p or 1080p/1080i/720p switchable
Picture elements	9.2 million pixels 1920 (H) x 4320 (V) effective
Digital quantization	14-bit A to D
Digital signal processing	74.25 MHz or 148.5 MHz, better than 22-bit accuracy
Sensitivity	2000 lux (186 ft cd) at F8.0 (typical, 1080i50 mode), reflectance 90%
Minimum illumination	Approx. 12 lux at F 1.4 and +12 dB gain
Exposure control	Down to 1/1000 s
Clean scanning	50.6 to 125 Hz (at 50 Hz) 61 to 150 Hz (at 59.94 Hz.)
Smear	no vertical smear
Optical system	F1.4 prism system
Optical filters	First: clear, 1/4 ND, 1/16 ND, 1/64 ND second: clear, 4-point star, 6-point star, soft focus
Modulation depth	55% at 27 MHz (typical, 720p mode)
S/N ratio	56 dB in Y (typical)
Registration	<25 ns (0.05% max.) in all zones, without lens
Dynamic range	>400%
Gain	-6dB to +15dB in 3dB steps or continuously variable
Colour matrices	6 standard, 2 variable
Colour temperature	4 standard, 2 memories and continuously variable

Item	Value
White balance range	2500 - 20,000 K
Highlight compression	Pivoting knee; Digital True Colour Knee
Digital contrast	Black stretch and black press
detail enhancement	Full amplitude RGB, extended dynamic range circuit
Skin tone memories	2
Viewfinder option types	(Model LDK 5302 2-inch) resolution >600 TV lines (centre) (Model LDK 5305 5-inch) resolution >650 TV lines (centre) (Model LDK 4021 7-inch) resolution >800 TV lines (centre)

8.2 Specifications for LDK 5860 TriaxHD adapter

Item	Value
Power requirements	Triax powered or 12 Vdc
Operating temperatures	-20 to +45°C (-4 to +113°F)
Storage temperatures	-20 to +60°C (-4 to +140°F)
Weight (approx.)	2.3 kg
Dimensions (LxWxH)	220 mm x 120 mm x 205 mm without handgrip
Triax in/out	Swivel Triax connector; type Fischer, ARD, Lemo or Trilock
Triax cable length	1,200m (4,000ft.) max. with 14 mm cable
Video out	2x HD-SDI (SMPTE 292M)
Monitor	BNC connector 1.0 Vpp; 75 Ohm
Teleprompter out or Reference in (local mode)	BNC connector 1.0 Vpp; 75 Ohm 0.6 Vpp HD tri-level reference signal
Tracker	11-pins communication / signalling connector
Auxiliary/ Data	11 pins private data
Rear microphone in (2x)	XLR-3, balanced, +48V phantom
Intercom	XLR-5 with channels ENG/PROD/PROG
DC input	12V, XLR-4 male
Scriptlight power output	12V, 0.25 A, 3-pin Fischer
DC output	12V, 1.5 A, 4-pin Hirose

8.2.1 Dimensions

Figure 8-1. Dimensions

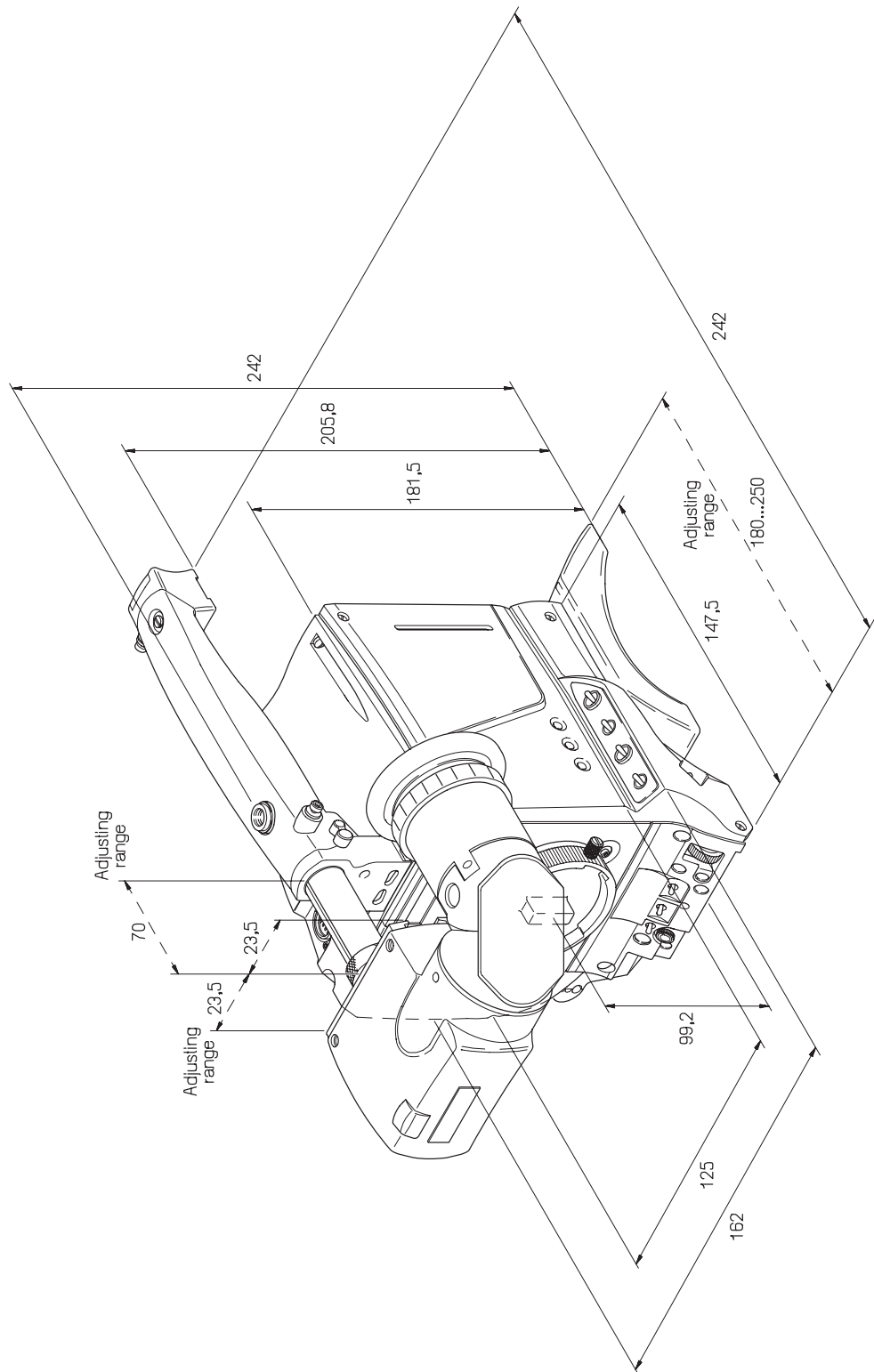

Free Manuals Download Website

<http://myh66.com>

<http://usermanuals.us>

<http://www.somanuals.com>

<http://www.4manuals.cc>

<http://www.manual-lib.com>

<http://www.404manual.com>

<http://www.luxmanual.com>

<http://aubethermostatmanual.com>

Golf course search by state

<http://golfingnear.com>

Email search by domain

<http://emailbydomain.com>

Auto manuals search

<http://auto.somanuals.com>

TV manuals search

<http://tv.somanuals.com>