

UNPACKING

The racer is fastened to the charge stand with a shipping screw. You will need to loosen the screw to free the racer from the charge stand.

Open the battery compartment cover on the bottom of the charging stand and loosen the shipping screw.

Thank you for purchasing the RadioShack Dodge Viper GTSR Supercharged Racer. Built to 1/43 scale, it can reach speeds up to 490 feet per minute. The digital proportional speed and steering controls on the pistol grip transmitter provides excellent control for the racer. The transmitter and vehicle also have a channel switch, so you and a friend can race your Vipers together by selecting a different position of the switch. The built-in Ni-MH battery of the vehicle can be charged about 300 times. The vehicle runs about eight minutes per 2.5-minute charge on the charge stand. The headlights and turn indicators turn on and off by remote control, giving you a real-life image of the vehicle. The foldable transmitter can even be carried around in your pocket!

! IMPORTANT !

If an icon appears at the end of a paragraph, go to the box on that page with the corresponding icon for pertinent information.

- ⚠ — Warning
- ! — Important
- ⚡ — Caution
- 💡 — Hint
- 📄 — Note

© 2002 RadioShack Corporation.
All Rights Reserved.
RadioShack and RadioShack.com
are trademarks used by
RadioShack Corporation.

⚠ WARNING ⚠
Dispose of batteries promptly and properly. Do not bury or burn batteries.

⚡ CAUTION ⚡

- Use only a fresh battery of the required size and recommended type.
- Do not mix old and new batteries, different types of batteries (standard, alkaline, or rechargeable), or rechargeable batteries of different capacities.
- If you do not plan to use the car or charge stand for a week or more, remove the batteries from the transmitter and the charge stand. Batteries can leak chemicals that can damage electronic parts.
- Never leave dead or weak batteries in the transmitter or the charge stand.

INSTALLING BATTERIES

IN THE TRANSMITTER

You need one 9V battery to power the transmitter. For the best performance and longest life, we recommend a RadioShack alkaline battery.

1. Unfold the transmitter so the grip snaps into place.
2. Slide the battery compartment cover to remove it.
3. Place the battery in the compartment as indicated by the polarity symbols (+ and -) marked inside.
4. Replace the cover.

When the transmitter's range decreases, or the power indicator flashes, replace its battery. ⚠ ⚡

IN THE CHARGE STAND

You need six AA batteries to charge the vehicle.

1. Slide the battery compartment cover on the bottom of the stand in the direction of the arrow and lift it off.
2. Put the batteries in the compartment as indicated by the polarity symbols (+ and -) marked inside.
3. Replace the cover and snap it shut.

When the charge stand does not seem to charge the vehicle, replace the batteries.

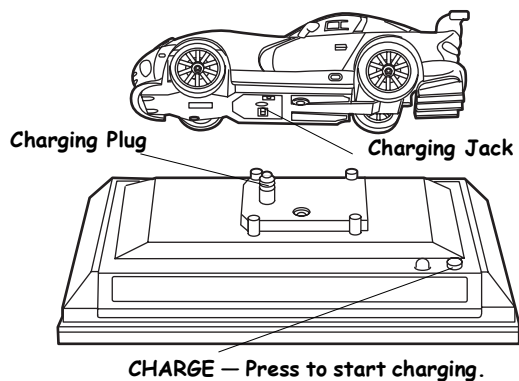

CHARGING THE VEHICLE

1. After installing the fresh batteries, place the vehicle on the charge stand so its plug fits into the jack on the vehicle.
2. Press the button on the charging stand so the red indicator turns on. The stand starts to charge the vehicle's battery.
3. When the indicator goes off, the charging cycle is complete. Remove the vehicle from the stand. ✓

INSTALLING THE TRANSMITTER ANTENNA

Thread the antenna into the transmitter's antenna connector. Make sure the connection is tight.

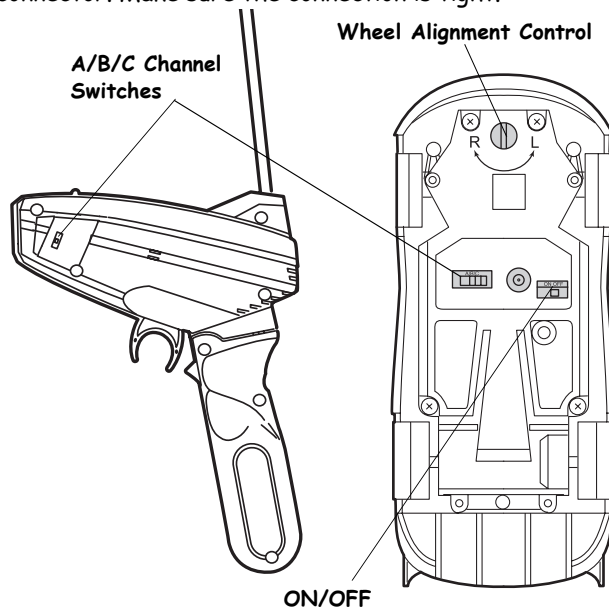

SETTING THE CHANNEL

The racer has three operation channels (A/B/C). You must set the transmitter and vehicle to the same channel. Set the channel switch on the bottom of the vehicle and on the back of the transmitter to the same position — A, B, or C. You might need a pair of tweezers to move the vehicle's switch.

NOTE

- Do not remove the vehicle from the charge stand while the indicator is on.
- You can charge the vehicle's battery whether the vehicle's power switch is on or off. With the switch set to ON during charging, you can enjoy blinking the vehicle's headlights or turn signals.
- Do not charge the vehicle's battery too often. Instead, run the vehicle until the battery fully discharges and the vehicle stops. Then charge the battery. This extends the battery's ability to fully recharge.
- Headlights, hazard indicators, and turn signals may operate even when the racer's battery has discharged to the point that it will not run. In this situation return the vehicle to the charging base.

DRIVING THE CAR

Fully extend the transmitter's antenna.

Slide **ON/OFF** on the transmitter and the vehicle to **ON**. You might need a pair of tweezers or a small precision screwdriver to move the vehicle's switch.

Use the transmitter's trigger and wheel to drive and steer the car. ⚠️

⚠️ CAUTION ⚠️

Do not drive the racer in puddles, on a wet floor, on sand, or in mud, rain, or snow. These can damage the vehicle.

Steering Control Wheel

- Rotate the wheel left to turn left
- Rotate the wheel right to turn right
- Release the wheel to go straight

TURN SIGNAL L — Press **TURN SIGNAL L** to turn the left indicator on or off. Pressing this button while the right indicator is on turns the right indicator off and the left indicator on.

TURN SIGNAL R — Press **TURN SIGNAL R** to turn the right indicator on or off. Pressing this button while the left indicator is on turns the left indicator off and the right indicator on.

HEADLIGHTS — Press **HEADLIGHTS** to turn the headlights on or off.

HAZARD — Press **HAZARD** to turn both turn indicators on or off.

Speed Control Trigger

- Pull the trigger to move forward.
- Pull the trigger all the way for maximum speed.
- Push the trigger to move backward.
- Release the trigger to stop.

When you finish playing with the car, slide the **ON/OFF** switches on the car and transmitter to **OFF**.

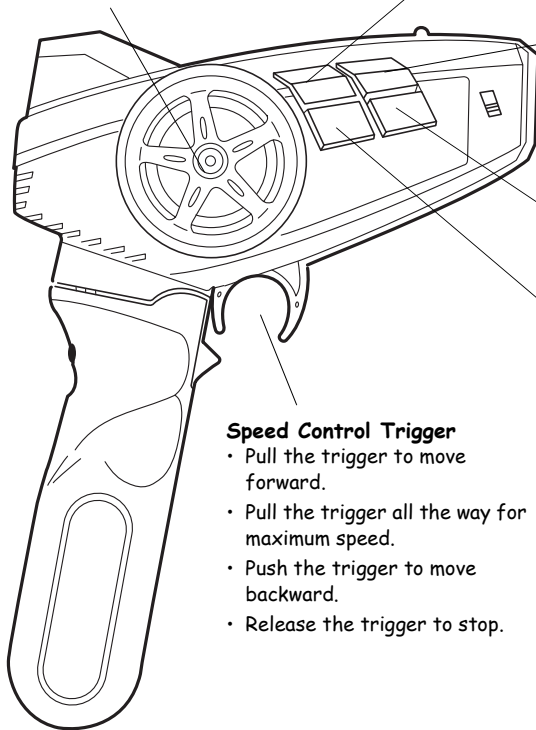

⚠️ WARNING ⚠️

- Do not play with your car in the street.
- This vehicle can reach much higher speeds than many other radio-controlled cars. Be careful to avoid high-speed collisions with people and objects.
- To avoid crashes, always watch where the vehicle is going.

ADJUSTING THE WHEEL ALIGNMENT

If the vehicle does not drive in a straight line when you release the steering wheel, adjust the wheel alignment control on the bottom of that car.

Rotate the control toward L if the car is pulling to the right. Rotate the control toward R if the car is pulling to the left.

Wheel Alignment Control

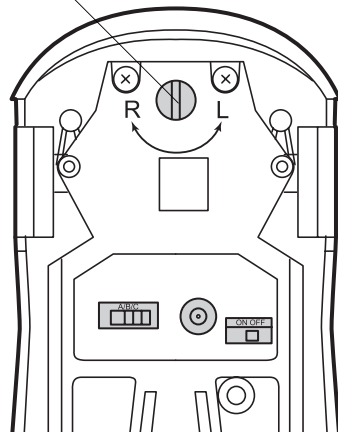

FOLDING THE TRANSMITTER

1. Press the button of the transmitter grip and fold the transmitter.
2. Unscrew the antenna and place it in the holder on the back of the transmitter.

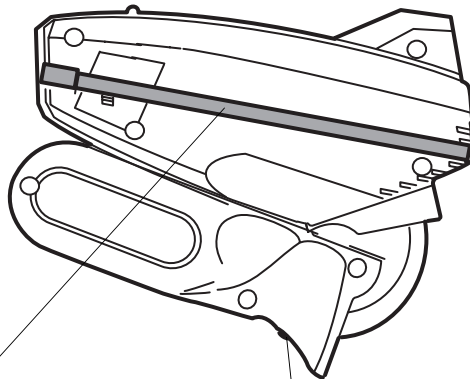

Step 2

Step 1

HELPFUL HINTS

If someone uses a CB nearby, it might interfere with control of the vehicle. If this happens, move the car away from the CB

Be sure the car is not out of the transmitter's range. The range depends on the surroundings and on battery strength. Obstructions such as buildings, fences, and so on, between the transmitter and the vehicle, reduce the range.

The vehicle has a special circuit to prolong battery life. If you keep the control wheel or control trigger in one position continuously for 40 seconds, the transmitter automatically shuts off. If this happens, move the control wheel or control trigger to another position to continue driving.

If the vehicle moves slowly even after you charge its battery, check the wheel mechanisms for lint, thread, hair, or dust.

When you are done with the racer, place it on the charging stand and put the cover. Do not hold the cover when you move it; always hold at the stand's base so as not to drop it.

CARE

Keep the vehicle dry; if it gets wet, wipe it dry immediately. Use and store the vehicle only in normal temperature environments. Handle the vehicle carefully; do not drop it. Keep the vehicle away from dust and dirt, and wipe it with a damp cloth occasionally to keep it looking new.

SERVICE AND REPAIR

If your vehicle is not performing as it should, take it to your local RadioShack store for assistance. Modifying or tampering with the vehicle's internal components can cause a malfunction, invalidate its warranty, and void your FCC authorization to operate it.

THE FCC WANTS YOU TO KNOW

This device complies with Part 15 of the FCC Rules. Operation is subject to the following two conditions:
(1) this device may not cause harmful interference, and
(2) this device must accept any interference received, including interference that may cause undesired operation.

Your vehicle or transmitter might cause TV or radio interference even when it is operating properly. To determine whether your vehicle or transmitter is causing the interference, turn off your vehicle and transmitter. If the interference goes away, your vehicle or transmitter is causing it. Try to eliminate the interference by:

- Moving your vehicle and transmitter away from the TV or radio.
- Contacting your local RadioShack store for help.

If you cannot eliminate the interference, the FCC requires that you stop using your vehicle and transmitter.

Limited Ninety-Day Warranty

This product is warranted by RadioShack against manufacturing defects in material and workmanship under normal use for ninety (90) days from the date of purchase from RadioShack company-owned stores and authorized RadioShack franchisees and dealers. EXCEPT AS PROVIDED HEREIN, RadioShack MAKES NO EXPRESS WARRANTIES AND ANY IMPLIED WARRANTIES, INCLUDING THOSE OF MERCHANTABILITY AND FITNESS FOR A PARTICULAR PURPOSE, ARE LIMITED IN DURATION TO THE DURATION OF THE WRITTEN LIMITED WARRANTIES CONTAINED HEREIN. EXCEPT AS PROVIDED HEREIN, RadioShack SHALL HAVE NO LIABILITY OR RESPONSIBILITY TO CUSTOMER OR ANY OTHER PERSON OR ENTITY WITH RESPECT TO ANY LIABILITY, LOSS OR DAMAGE CAUSED DIRECTLY OR INDIRECTLY BY USE OR PERFORMANCE OF THE PRODUCT OR ARISING OUT OF ANY BREACH OF THIS WARRANTY, INCLUDING, BUT NOT LIMITED TO, ANY DAMAGES RESULTING FROM INCONVENIENCE, LOSS OF TIME, DATA, PROPERTY, REVENUE, OR PROFIT OR ANY INDIRECT, SPECIAL, INCIDENTAL, OR CONSEQUENTIAL DAMAGES, EVEN IF RadioShack HAS BEEN ADVISED OF THE POSSIBILITY OF SUCH DAMAGES.

Some states do not allow limitations on how long an implied warranty lasts or the exclusion or limitation of incidental or consequential damages, so the above limitations or exclusions may not apply to you.

In the event of a product defect during the warranty period, take the product and the RadioShack sales receipt as proof of purchase date to any RadioShack store. RadioShack will, at its option, unless otherwise provided by law: (a) correct the defect by product repair without charge for parts and labor; (b) replace the product with one of the same or similar design; or (c) refund the purchase price. All replaced parts and products, and products on which a refund is made, become the property of RadioShack. New or reconditioned parts and products may be used in the performance of warranty service. Repaired or replaced parts and products are warranted for the remainder of the original warranty period. You will be charged for repair or replacement of the product made after the expiration of the warranty period.

This warranty does not cover: (a) damage or failure caused by or attributable to acts of God, abuse, accident, misuse, improper or abnormal usage, failure to follow instructions, improper installation or maintenance, alteration, lightning or other incidence of excess voltage or current; (b) any repairs other than those provided by a RadioShack Authorized Service Facility; (c) consumables such as fuses or batteries; (d) cosmetic damage; (e) transportation, shipping or insurance costs; or (f) costs of product removal, installation, set-up service adjustment or reinstallation.

This warranty gives you specific legal rights, and you may also have other rights which vary from state to state.

RadioShack Customer Relations, 200 Taylor Street, 6th Floor, Fort Worth, TX 76102

12/99

RadioShack Corporation
Fort Worth, Texas 76102

60-4340
07A02
Printed in China

Free Manuals Download Website

<http://myh66.com>

<http://usermanuals.us>

<http://www.somanuals.com>

<http://www.4manuals.cc>

<http://www.manual-lib.com>

<http://www.404manual.com>

<http://www.luxmanual.com>

<http://aubethermostatmanual.com>

Golf course search by state

<http://golfingnear.com>

Email search by domain

<http://emailbydomain.com>

Auto manuals search

<http://auto.somanuals.com>

TV manuals search

<http://tv.somanuals.com>