

XMODS™ Custom RC

All Wheel Drive Kit 60-8506









Upgrade your XMODS custom RC from standard two-wheel drive to all-wheel drive for improved traction and cornering. Before installing this kit, turn off your vehicle and controller, and detach the car body.

The All-Wheel Drive kit includes:

- Rear differential gear
- Drive shaft cone gear
- Front left and right steering assembly w/differential gear
- Left and right rear arms (*optional installation*)
- Tube of grease

Note: Although the front and rear differential gears appear similar, they are not. DO NOT USE THEM INTERCHANGEABLY! In the event of mix up, carefully unscrew one gear into two halves. If the gear has metal bearings inside, this is the rear differential. If not, the gear is the front differential.

Screw Table

Screw								
Location	Front and Rear Dampers	Front Upper Deck (long)	Front Upper Deck (short)	Left and Right Front Knuckles	Front Lower Deck	Rear Upper Deck (short)	Rear Upper Deck (long)	Rear Lower Deck
Number	4	2	2	2	4	4	2	4

Preparing for Your All-Wheel Drive Upgrade

1

Use the lug wrench supplied in your XMODS™ Starter Kit to detach the front **lug nuts** and **wheels**.

2

Loosen and remove each damper screw and detach the **right** and **left front and rear dampers**.

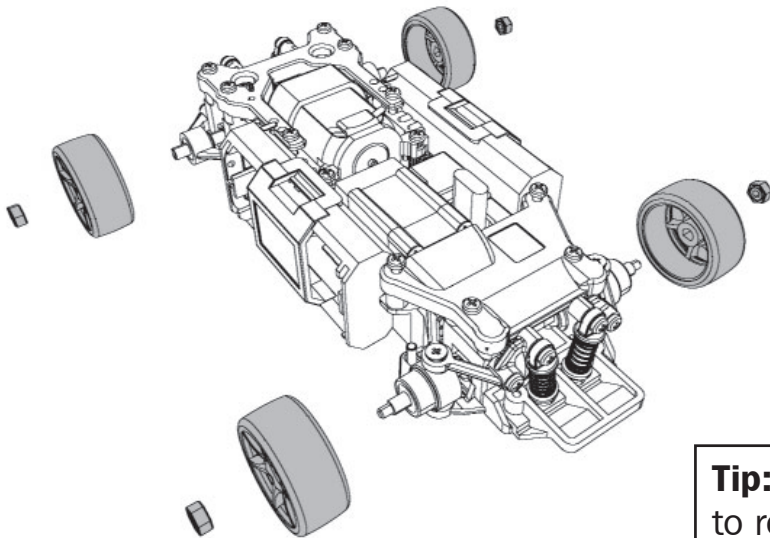

Tip: You may find it useful to remove the antenna from the chassis.

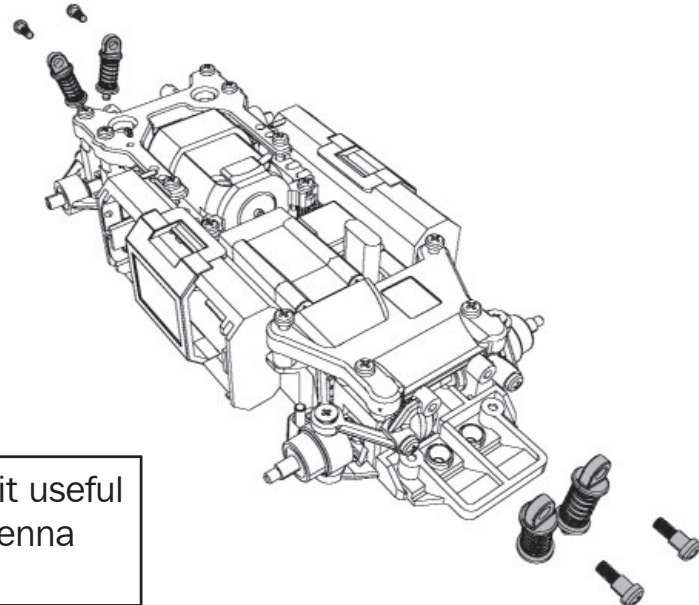

Front Section All-Wheel Drive Installation

1

Loosen and remove each screw beneath the **right** and **left front knuckles**. Loosen and remove the four screws beneath the **front arm base**.

2

Unscrew and remove the two rear screws on the **front upper deck**. Lift up and remove the **front upper deck** along with the **left** and **right steering assemblies**.

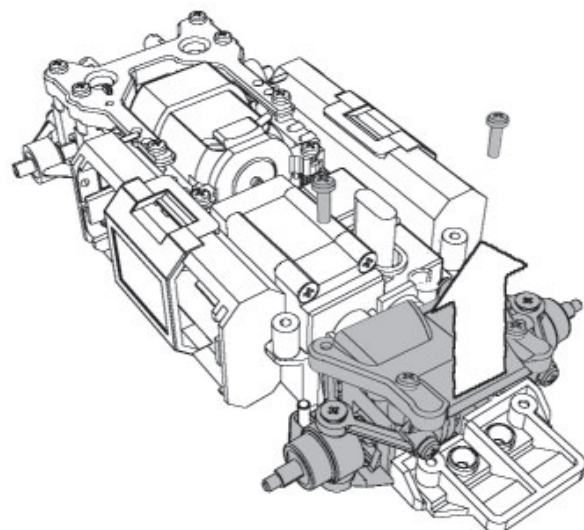
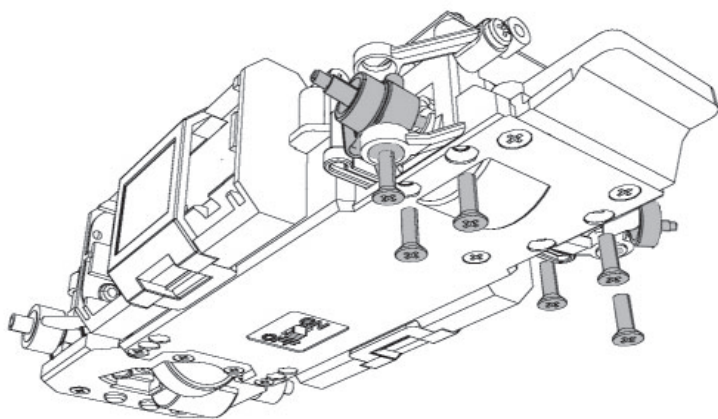

Note: You will not need the front left and right steering assemblies unless you encounter a need to remove the all-wheel drive upgrade.



3

Install the **cone gear** on the chassis' drive shaft. Be sure to align the shaft's D-cut with the hole in the **cone gear**.

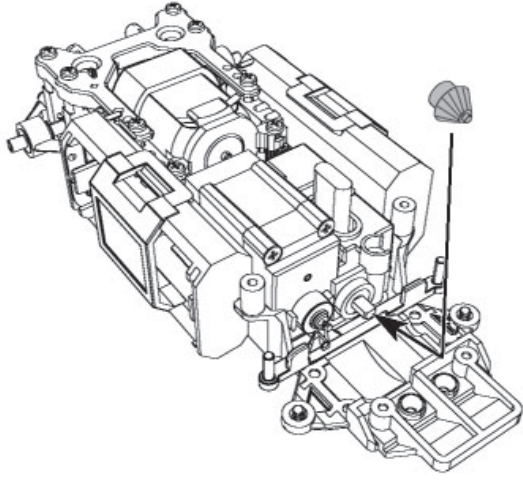

4

Discard the bottom shipping plate of the **front all-wheel drive steering assembly** after unscrewing and removing all bottom screws. Then, carefully place the **steering assembly** on the **front lower plate** of the chassis.

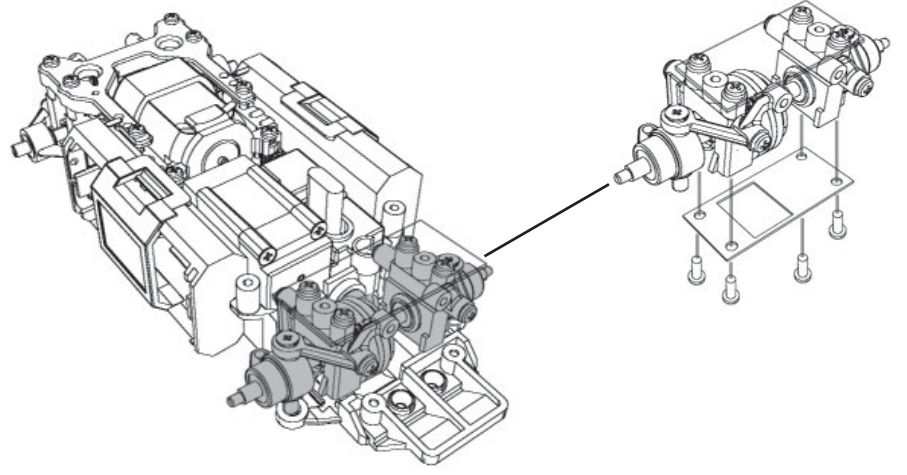

5

Insert the **tie rod** tips into the hole at the base of the **left** and **right turn knuckles**. Screw the four **front lower deck** screws into the **all-wheel drive steering assemblies**. Screw the two **turn knuckle** screws into the **front lower deck**.

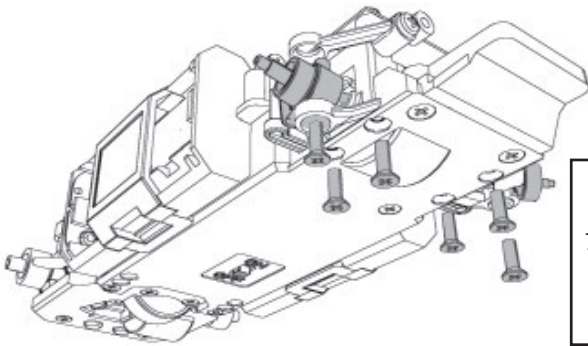

Note: Be sure the universal joints have not disengaged from the differential axles before screwing the assembly into place.

6

Remove and discard the top shipping plate from the **front all-wheel drive steering assemblies** and screw the **front upper deck** back into place.

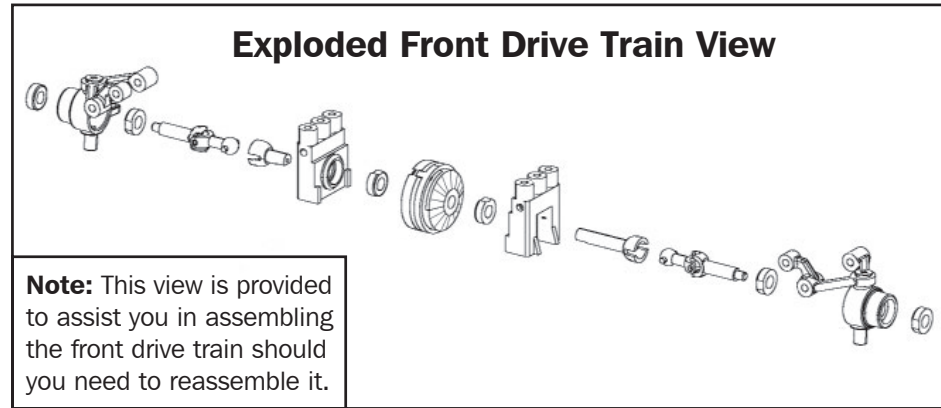

Exploded Front Drive Train View

Note: This view is provided to assist you in assembling the front drive train should you need to reassemble it.

Rear Section All-Wheel Drive Installation

For longest life and optimum performance you must replace the rear differential with the **all-wheel drive differential**; however, replacing the **left** and **right suspension arms** is not required.

1

Loosen and remove the six screws in the **rear upper deck**.

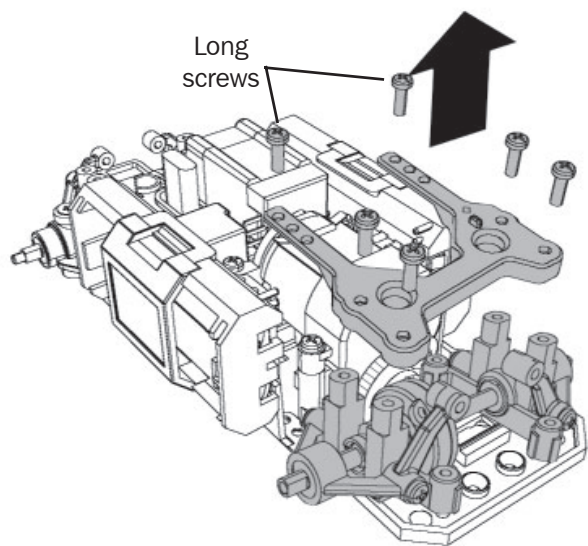

2

Remove the four screws in the **rear lower deck** and then carefully lift and remove the rear axle assembly away from the lower deck.

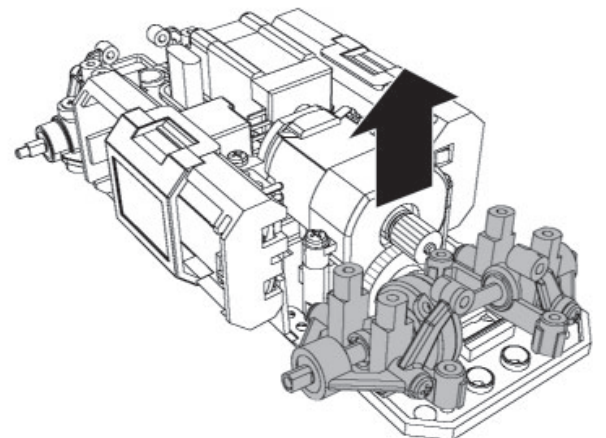
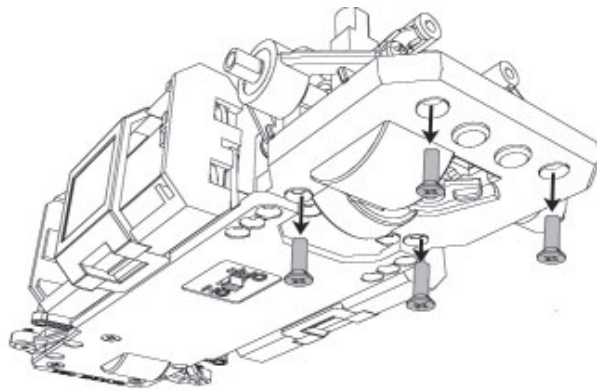

3

Carefully separate the rear axle at the differential and replace it with the new rear **differential** gear.

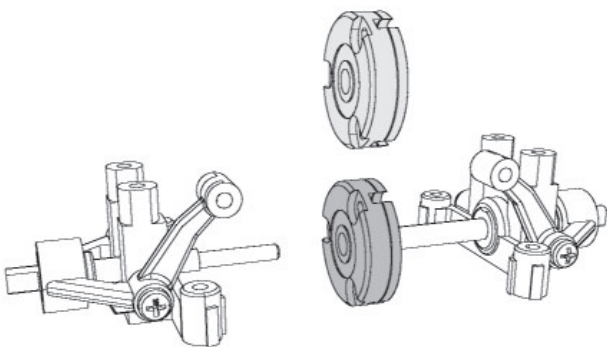

4

Reassemble the rear section of your car in reverse order. Reassemble the front and rear **dampers** and **wheels**.

5

Perform this step ONLY if your car will be driven indoors exclusively, as the grease can collect dirt and dust! Apply a dab of **grease** between the **front bevel gears** and another dab between the **rear bevel gears**.

CAUTION: KEEP GREASE OUT OF REACH OF SMALL CHILDREN.

Grease contains White Mineral Oil and Li-Ca complex soap. Avoid prolonged and/or repeated skin contact. May cause skin irritation/dermatitis. Remove soiled or soaked clothing immediately.

FIRST AID

EYES: Flush with plenty of water. Call physician or poison center immediately.

SKIN: Wash with soap and plenty of water; apply skin cream. If irritation persists, get immediate medical attention.

INGESTION: If swallowed do not induce vomiting unless directed by a physician. Call physician or poison center immediately. For Medical Emergencies, call Poison Center (303) 623-5716.



Free Manuals Download Website

<http://myh66.com>

<http://usermanuals.us>

<http://www.somanuals.com>

<http://www.4manuals.cc>

<http://www.manual-lib.com>

<http://www.404manual.com>

<http://www.luxmanual.com>

<http://aubethermostatmanual.com>

Golf course search by state

<http://golfingnear.com>

Email search by domain

<http://emailbydomain.com>

Auto manuals search

<http://auto.somanuals.com>

TV manuals search

<http://tv.somanuals.com>