



Owner's Manual



X•K•Ka Superwide Radar/ Laser Detector

Please read before using this equipment.



Cat. No. 22-1667

RadioShack™

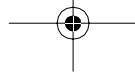

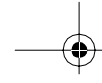

FEATURES



Your RadioShack X•K•Ka Superwide Radar/Laser Detector can alert you to all known police traffic radar and laser systems. It receives all X-, K-, and Ka-band traffic radar signals and also detects both the instant-on and laser systems many police departments now use to measure vehicle speed.

Your detector has many useful features, including:

VG-2 Protection — makes your detector invisible to the VG-2 radar-detector detector by sensing VG-2 and shutting down until you are out of range.

Front- and Rear-Looking Laser — detects laser signals from both the front and the rear of your vehicle.

Safety Warning System™ Detection — alerts you to the presence of potential road hazards and emergency vehicles signalled by a safety warning system transmission.

X-, K-, Ka-Band, and Laser Signal Detection — warns you when it detects signals from traffic radar or laser devices. Different tones sound to let you know the type of signal received.

City/Highway Modes — let you minimize alerts when you are in areas that have false radar sources.

FAST (False Alert Suppression Technology) — helps prevent false alarms caused by non-traffic radar sources.

© 1996 Tandy Corporation.
All Rights Reserved.

RadioShack and FAST are trademarks used by Tandy Corporation.
Safety Warning System and SWS are trademarks of
Safety Warning System LLC.

InstaClear is a registered trademark used by Ford Motor Company.
ElectriClear is a registered trademark used by Libbey, Owens, Ford,
and Delco-Remy.

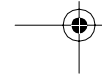
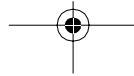
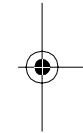
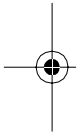



Your radar/laser detector includes the following items:

- Power Cord
- Hook and Loop Fastener
- Windshield Bracket
- Owner's Manual with Suction Cups

We recommend you record your detector's serial number here. The number is on the detector's bottom panel.

Serial Number: _____

Note: Some areas have laws regulating the use of radar detectors. Check with your local law enforcement agency about the laws in your area.

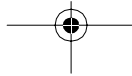
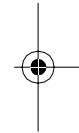
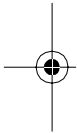

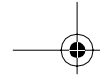

CONTENTS

A Quick Look	5
Installation	7
Mounting Guidelines	7
Hook-and-Loop Tape Mounting	8
Windshield Mounting	9
Connecting Power	10
Operation	11
Turning the Detector On and Off	11
Adjusting the Volume	12
Demonstrating Alerts	12
Muting Alerts	12
Selecting the City and Highway Modes	13
Setting the VG-2 Option	14
Receiving and Identifying Alert Signals	14
Resetting the Detector	15
Troubleshooting	16
Replacing the Fuse	18

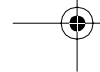
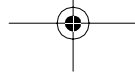
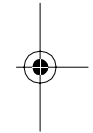
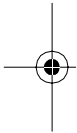

A QUICK LOOK

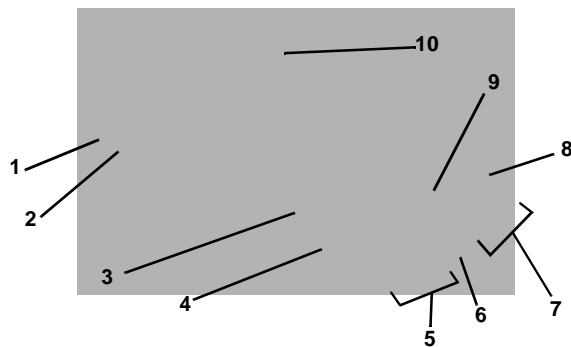

- 1 Bracket Release Button** — lets you quickly remove the detector's bracket.
- 2 Power Jack** — the power cable plugs in here.
- 3 Speaker** — sounds distinct warnings.
- 4 P•V Button** — turns the detector on and off and lets you adjust the volume.
- 5 Visual Radar Indicators** — the appropriate indicator lights when the detector detects a traffic radar signal.
- 6 H•C Indicator** — green when the detector is in the highway mode; yellow when the detector is in the city mode.
- 7 ALERT Meter** — four high-intensity indicators show the strength of the detected signal.

5

-
- 8 **MUTE Button** — lets you silence alerts.
 - 9 **CITY (CITY/HIGHWAY) Button** — switches between the city and highway modes.
 - 10 **Rear Laser Detection Lens** — receives incoming laser signals from the rear.

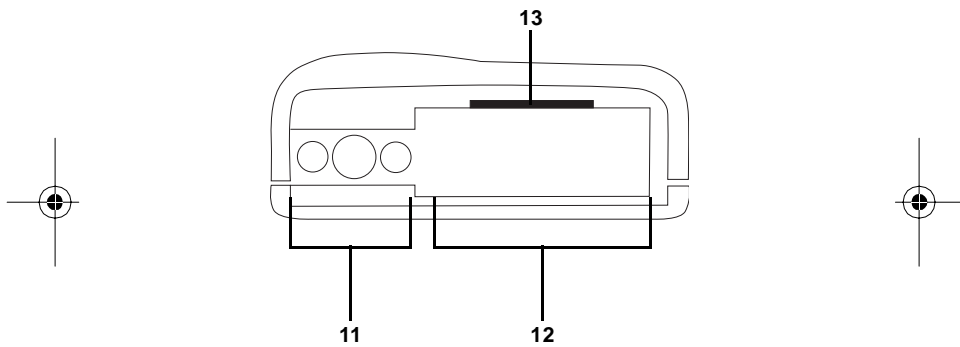

- 11 **Front Laser Detection Lens** — receives incoming laser signals from the front.
- 12 **Radar Detection Antenna** — receives the incoming radar signals.
- 13 **Mounting Bracket Slot** — holds the windshield mounting bracket.

6

INSTALLATION

MOUNTING GUIDELINES

Follow these guidelines when selecting a location.

- Choose a location that does not block the driver's view of the road.
- Mount the detector in a level position with a clear view to both the front and rear.
- The detector's view of the road must not be blocked by any metal object.
- Some vehicles have InstaClear® or ElectriClear® defogging windshields, which have metal coatings that block signals. General Motor's APV vans have a solar shield that keeps the vehicle cooler during the summer, but also blocks signals. A detector installed in a vehicle with any of these features will probably not detect a signal.
- Since window tinting reduces the received strength of laser signals, you should not mount the detector behind any tinted glass.
- Do not mount the detector where the driver or a passenger might hit it in a sudden stop or accident.

Caution: Whichever mounting method you choose, place the detector out of view when you leave the vehicle. This keeps the detector out of sight of thieves and prevents exposing it to extremely high temperatures, which can temporarily impair performance.

HOOK-AND-LOOP TAPE MOUNTING

For some dashboards, the hook-and-loop tape included with your detector might be best for mounting. Follow these steps to use the hook-and-loop tape.

1. Use a damp cloth to clean the bottom of the detector and the dashboard. Let both surfaces dry.

Note: The tape's adhesive might not stick to a surface treated with vinyl cleaner or protectant.

2. Remove the tape's backing and stick the tape to the bottom of the detector.

Note: Do not place the hook-and-loop tape over the detector's serial number.

On a curved dashboard, cut the supplied strip in half and use one strip on each side of the bottom of the detector.

3. Remove the backing from the other side of the tape and press the detector onto the dashboard.

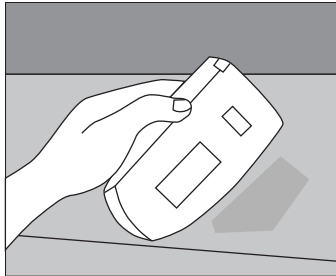

WINDSHIELD MOUNTING

The supplied suction-cup windshield bracket lets you easily mount the detector on the windshield.

Caution: Do not use the bracket in a vehicle that has a plastic coating on the windshield designed to protect passengers during an accident. If you use the bracket on this type of windshield, you might permanently mar the windshield's surface.

1. Align the groove in each suction cup with the slots in the windshield bracket and slide the suction cups out until they lock into place.
2. Press the supplied black rubber windshield mount stop into the small hole on the windshield bracket.
Note: You might need to slightly twist the stop to get it to pop into the hole.
3. Clean the selected windshield area, position the bracket on the windshield, and press firmly on each suction cup to secure it in place.
4. Slide the radar detector onto the base plate until it snaps into place.

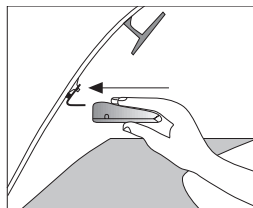

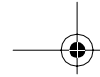

-
- To level the detector, press the bracket release button to remove the bracket from the detector. Then bend the bracket.

CONNECTING POWER

Caution:

- Unplug the power cord's cigarette-lighter plug from your vehicle's cigarette-lighter socket when you turn off the ignition. This prevents your vehicle's battery from being drained if you leave the detector on when you turn off the ignition.
- Before plugging the power cord's cigarette-lighter plug into your vehicle's cigarette-lighter socket, make sure the plug's tip is screwed firmly onto the plug. See "Replacing the Fuse" on Page 18 for more information about the cigarette-lighter plug.
- Use only the supplied power cord. If your power cord is lost or damaged, you can order a replacement cord from your local RadioShack store.

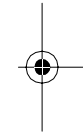
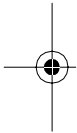

Plug the supplied power cord's short barrel plug into the detector's power jack. Then plug the cord's cigarette-lighter plug into your vehicle's cigarette-lighter socket.

Note: If the detector does not operate when you turn it on, remove the cigarette-lighter plug from your vehicle's socket and check the socket for debris. Also check the fuse in the cigarette-lighter plug and your vehicle's fuse block (see "Replacing the Fuse" on Page 18).



10

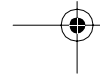
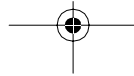

OPERATION

TURNING THE DETECTOR ON AND OFF

To turn on the detector, press and release **P•V**.

The detector sounds a distinctive alert and lights the indicators for each band as a self test, in the order presented in the following table. Then all indicators turn off except the power indicator, and the detector returns to the same operating modes as the last time you used it.

Alert Type	Audible Alert	Visual Alert
X	Low steady	X + all ALERT indicators
K	High trill	K + all ALERT indicators
Ka	Medium warble	Ka + all ALERT indicators
Safety	Low-high	First and fourth ALERT indicators
Laser	High-low	ALERT indicators scroll right-to-left
VG-2	None	Third ALERT indicator

To turn off the detector, press and release **P•V** again.

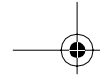

ADJUSTING THE VOLUME

The detector has four volume levels. To change the detector's volume, press and hold down **P•V**. The detector sounds tones at the current volume level. When the detector reaches full volume, the fourth ALERT indicator turns on. When the detector reaches minimum volume, the first ALERT indicator turns on.

Note: When the detector reaches either the maximum or minimum volume, you must release and press **P•V** again to reverse the volume direction.

DEMONSTRATING ALERTS

To familiarize yourself with the different alerts your detector produces, you can run a demonstration. To start the demonstration, press and release **MUTE** and **CITY** at the same time with the detector turned on. The detector demonstrates the alerts for X, K, Ka, safety warning, laser, and VG-2, in that order. To end the demonstration, press **P•V**.

MUTING ALERTS

While a radar, laser, or safety warning alert is sounding, you can press **MUTE** to temporarily silence the detector for the current alert and any new alert that is produced within 10 seconds. Visual alerts are not affected.

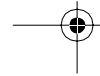
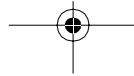

SELECTING THE CITY AND HIGHWAY MODES

In the city mode, the detector sounds only two alert tones when it detects weak speed or safety radar signals. If the signal strength becomes stronger, it sounds two additional beeps. The ALERT indicators continue to react immediately to traffic radar signals to keep you quietly informed.

Note: The city mode has no effect on laser or VG-2 operation.

To select the city mode, press **CITY** until the H•C indicator turns yellow. The detector beeps once.

The highway mode provides maximum alert response for open-road driving.

To select the highway mode, press **CTY** until the H•C indicator turns green. The detector beeps twice.

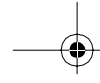

SETTING THE VG-2 OPTION

VG-2 is a system used by some law enforcement agencies that detects the use of radar detectors in vehicles. It does this by detecting the weak radio signals used in radar detectors. Your radar detector can sense a VG-2 system and shift its operating frequencies out of the range detected by VG-2, making your radar detector essentially invisible to this system.

To turn the VG-2 option on or off, press **P•V** and **MUTE** at the same time. Then press **CITY**. The third ALERT indicator turns on and the detector beeps once to indicate the VG-2 option is on. If the VG-2 option is off, the ALERT indicator turns off and the detector beeps once.

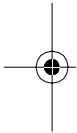

After you set this feature, press **P•V** again. The detector beeps.

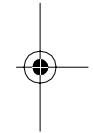

RECEIVING AND IDENTIFYING ALERT SIGNALS

Your detector gives different audible alerts for each signal. In addition, the alert tone pulse rate increases with signal strength. (See "Demonstrating Alerts" on Page 12 to find out how the detector alerts you to X-, K-, Ka-band, safety warning system, laser, and VG-2 signals.)

When your detector senses instant-on radar, it sounds an intense, 3-second tone and flashes all ALERT indicators.

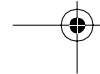
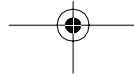

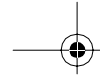

Some emergency services, such as ambulances, fire trucks, police, and road crews, are equipped with a special transmitter that can alert you to their presence.

When your detector senses a safety warning system signal, it beeps a tone and lights the first and fourth ALERT indicators. The audible alert beeps faster as the signal strength increases.

Note: Your detector does not detect X, K, Ka, or safety warning signals when it is sensing a VG-2 radar-detector detector.

RESETTING THE DETECTOR

The detector keeps the audio level, city mode, VG-2 option, and power state (on or off) in memory when power is removed. When you reapply power, it returns to these same settings.

To reset the detector to its factory default settings, unplug the detector's power cord from the cigarette-lighter socket, press and hold **P•V** and **MUTE**, plug in the power cord, wait for two beeps, then release **P•V** and **MUTE**. The detector turns off the VG-2 option, returns to highway mode, and sets the volume to its default level.

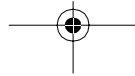
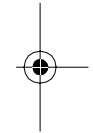
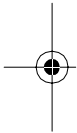

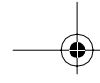

TROUBLESHOOTING



If you have problems operating your radar/laser detector, the suggestions in this section might help. If you cannot solve the problem after trying these suggestions, take your detector to your local RadioShack store for assistance.

If the detector does not turn on:

- Be sure all power connections are secure.
- Check the fuse that controls power to the cigarette-lighter socket. See your vehicle's owner's manual.
- Check the fuse in the cigarette-lighter plug. See "Replacing the Fuse" on Page 18.
- The cigarette-lighter socket might be dirty. Clean it to give a good, clean connection.

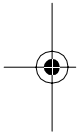

Caution: Do not place any metal object other than the cigarette lighter or a cigarette-lighter plug in the cigarette-lighter socket. Doing so could blow a fuse in your vehicle or cause the metal object to become very hot.

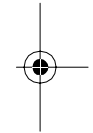

If the detector gives a false alert when the vehicle hits bumps in the road:

- Check the power connections.

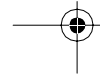
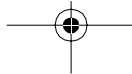

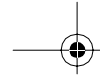

If the detector gives a false alert when you use accessories such as power windows, motorized mirrors, brakes, and so on:

- Check the vehicle's electrical system, including the main battery cable and alternator connections.
- Install a filter capacitor (1,000 μ f, 35 volts, such as Cat. No. 272-1032) on the back of the cigarette-lighter socket, across the power connections.

If the detector performs the power on self-test (see "Turning the Detector On and Off" on Page 11), but does not respond to radar signals when you see a police car:

- A police car might not be equipped with radar, or might be using instant-on radar and not have the radar gun triggered (see the separate booklet *Questions and Answers About Vehicle Speed Detection*).
- Police might be using VASCAR-type speed detection (see the separate booklet *Questions and Answers About Vehicle Speed Detection*).

If the detector has poor laser detection range:

- Be sure the laser detection lenses are not blocked.
- Use lens-cleaning solution to clean the laser detection lenses.

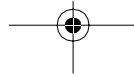
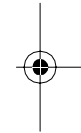
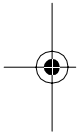

REPLACING THE FUSE

If the detector stops operating, check the fuse in the DC power cord's cigarette-lighter plug. If it has blown, follow these steps to replace it with a 2-Amp, $1\frac{1}{4} \times \frac{1}{4}$ mm, fast-acting fuse (Cat. No. 270-1007).

Caution: Using a fuse that does not meet these ratings or defeating the fuse protection can damage your detector or the vehicle's electrical system.

1. Carefully unscrew the tip of the cigarette-lighter plug.

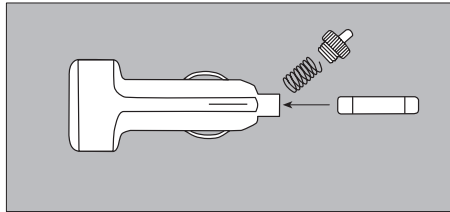

2. Remove the tip from the cigarette-lighter plug, then remove the old fuse.

Note: Take care not to lose the spring inside the holder, or the metal ring.

3. Replace the fuse.
4. Press the cigarette-lighter plug's tip down into the body, then screw it back in.

Caution: Be sure you press the cigarette-lighter plug's tip down before screwing it in, or you might damage the plug.

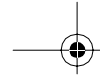

NOTES

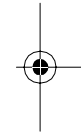
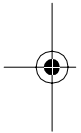

One or more of the following patents apply: 4,315,261;
5,146,227; 5,379,456. Other patents pending.

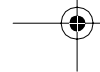
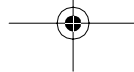

RadioShack Limited Warranty

This product is warranted against defects for 1 year from date of purchase from RadioShack company-owned stores and authorized RadioShack franchisees and dealers. Within this period, we will repair it without charge for parts and labor. Simply **bring your RadioShack sales slip** as proof of purchase date to any RadioShack store. Warranty does not cover transportation costs. Nor does it cover a product subjected to misuse or accidental damage.

EXCEPT AS PROVIDED HEREIN, RadioShack MAKES NO EXPRESS WARRANTIES AND ANY IMPLIED WARRANTIES ARE LIMITED IN DURATION TO THE DURATION OF THE WRITTEN LIMITED WARRANTIES CONTAINED HEREIN. Some states do not permit limitation or exclusion of implied warranties; therefore, the aforesaid limitation(s) or exclusion(s) may not apply to the purchaser.

This warranty gives you specific legal rights and you may also have other rights which vary from state to state.

We Service What We Sell

10/95

RadioShack
A Division of Tandy Corporation
Fort Worth, Texas 76102

7/96

Printed in the USA

Free Manuals Download Website

<http://myh66.com>

<http://usermanuals.us>

<http://www.somanuals.com>

<http://www.4manuals.cc>

<http://www.manual-lib.com>

<http://www.404manual.com>

<http://www.luxmanual.com>

<http://aubethermostatmanual.com>

Golf course search by state

<http://golfingnear.com>

Email search by domain

<http://emailbydomain.com>

Auto manuals search

<http://auto.somanuals.com>

TV manuals search

<http://tv.somanuals.com>