

# UNIVERSAL REMOTE CONTROL

**Ramsey Electronics Model No.                      URC1**

*Do you need to turn things on and off through your telephone or HAM radio? Do you need to remotely access repeaters, your cottage thermostat, or your home security lights? This is the kit for you! The URC1 is a Fully expandable system to control 64 outputs, four variable voltage levels, two variable resistances, and three real time timers, all through DTMF tones! All of this with full password protection, comprehensive codes, and expandability!*

- **Six digit display for long codes**
- **Fast DTMF decoding time for automatic phone dialers**
- **Sensitive and accurate audio input for faint tones**
- **Tone feedback for confirmation of commands**
- **Full microprocessor control for ease of use**
- **Included are 15 switched outputs, 4 adjustable voltage outputs (0-5VDC), 2 digital pots, and 3 real time timers with on and off times adjustable from 10 ms to 40 hours.**
- **Two levels of password protection, with a master as well as a user password.**
- **Add our matching case and knob set for a finished "pro-look."**
- **Informative manual answers questions on theory, hook-ups and uses - enhances resale value, too!**

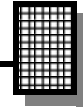

---

#### RAMSEY TRANSMITTER KITS

- FM100 Professional FM Stereo Transmitter
- FM25 Synthesized Stereo Transmitter
- AM1, AM25 AM Transmitters
- TV6 Television Transmitter

#### RAMSEY RECEIVER KITS

- FR1 FM Broadcast Receiver
- AR1 Aircraft Band Receiver
- SR2 Shortwave Receiver
- AA7 Active Antenna
- SC1 Shortwave Converter

#### RAMSEY HOBBY KITS

- SG7 Personal Speed Radar
- SS70A Speech Scrambler
- SP1 Speakerphone
- WCT20 Wizard Cable Tracer
- PH10 Peak hold Meter
- LC1 Inductance-Capacitance Meter

#### RAMSEY AMATEUR RADIO KITS

- FX146 VHF Transceivers
- HR Series HF All Mode Receivers
- QRP Series HF CW Transmitters
- CW700 Micro Memory CW Keyer
- CPO3 Code Practice Oscillator
- Packet Computer Interfaces
- QRP Power Amplifiers

#### RAMSEY MINI-KITS

Many other kits are available for hobby, school, Scouts and just plain FUN. New kits are always under development. Write or call for our free Ramsey catalog.

#### URC1 UNIVERSAL REMOTE CONTROL INSTRUCTION MANUAL

Ramsey Electronics publication No. MURC1 Revision 1.2

First printing: June 1994

COPYRIGHT 1993 by Ramsey Electronics, Inc. 793 Canning Parkway, Victor, New York 14564. All rights reserved. No portion of this publication may be copied or duplicated without the written permission of Ramsey Electronics, Inc. Printed in the United States of America.

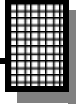

---

## KIT ASSEMBLY AND INSTRUCTION MANUAL FOR

# URC1 UNIVERSAL REMOTE CONTROL

### TABLE OF CONTENTS

|                                  |    |
|----------------------------------|----|
| Introduction to the URC1 .....   | 4  |
| How it works .....               | 5  |
| Tips and Notes .....             | 6  |
| Parts list .....                 | 7  |
| URC1 Assembly instructions ..... | 8  |
| Initial testing .....            | 14 |
| Troubleshooting tips .....       | 15 |
| Hints and Using .....            | 16 |
| Setup .....                      | 19 |
| Charts and diagrams .....        | 20 |
| Control codes .....              | 22 |
| Notes and passwords .....        | 27 |
| Connector Considerations .....   | 28 |
| Expanding notes .....            | 28 |
| Schematic diagram .....          | 29 |
| Parts Layout diagram .....       | 30 |
| Ramsey kit warranty .....        | 31 |



**RAMSEY ELECTRONICS, INC.**  
793 Canning Parkway  
Victor, New York 14564  
Phone (716) 924-4560  
Fax (716) 924-4555

### **URC1 REMOTE CONTROL FEATURES:**

- Six digit display for long codes
- Fast DTMF decoding time for fast automatic phone dialers
- Sensitive audio input for faint tones
- Tone feedback for confirmation of commands
- Accurate decoding, rejects dial tones and normal audio
- Small size, runs on 7 to 15 VDC.
- Fully microprocessor controlled for ease of use
- Has many features, and is fully expandable
- Included are 15 switched outputs, 4 adjustable voltage outputs (0-5VDC), 2 digital pots, and 3 real time timers that on and off times are adjustable from 10 ms to 40 hours.
- Expandable to 48 more switched outputs, and two more pots.
- Two levels of password protection, with a master as well as a user password.
- Everything is included to get the unit up and running, all that is required is a power supply, and some source of DTMF tones.
- Add our matching case and knob set for a finished "pro-look."

### **INTRODUCTION TO THE RAMSEY URC1:**

The Ramsey URC1 is a microprocessor controlled remote control that uses DTMF for turning voltage levels up and down, pots up and down, timers on and off, and outputs on and off. It uses the 0-9 digits as well as the \* and # digits of a DTMF encoder, but can also use A-D tones for password protection. Having two levels of password protection, the master (who owns or runs the URC) can prevent the user (anyone else) from changing the states of selected controls, which prevents a user from turning on something that does not need to be turned on. A six digit display shows the valid codes that were pressed, and shows errors along the way. The display blanks during passwords as well as when the unit is finished being accessed to save on power.

NOTE TO NEWCOMERS: If you are a first time kit builder you may find this manual easier to understand than you may have expected. Each part in the kit is checked off as you go, while a detailed description of each part is given. If you are to follow each step in the manual in order, and practice good soldering and kit building skills, the kit is next to fail-safe. If a problem does occur, the manual will lead you through step by step in the troubleshooting guide until you find the problem and are able to correct it.

## **HOW THE URC1 WORKS:**

Take a look at the URC1's schematic diagram as we walk through the circuit. As you can see there is not much to the universal remote control, most of the work is internal to the IC's.

The real heart of the circuit is U6 the microcontroller IC. This 20 pin IC can perform an amazing amount of tasks, quickly as well as reliably. This IC controls all of the outputs as well as the display, and also processes the codes decoded from U5, the tone decoder IC.

U5, the tone decoder IC does most of the complicated work in this kit. Internally this chip has a set of counters that latch different outputs depending on the tones. The internal counters are referenced to a television colorburst crystal operating at 3.579 Mhz. This reference frequency is used also as the clock frequency to pin 10 of U5 the microprocessor.

U1, and U3 are serial shift registers. Data is clocked into them bit by bit from the microprocessor, and then latched to the outputs by a change in state on the LDS line. One of the outputs from these chips is used to deliver a tone output for confirmation of commands.

U4 is a digitally controlled dual potentiometer. A very versatile device, it can control volumes, levels, tuning on most Ramsey kits, thermostats, and whatever else a pot can be used in.

U7 is a quad serial digital to analog converter. This provides the 0-5VDC levels in 256 steps. These levels can be used to control dimmers, thermostats, motor speed controllers, and anything else you can come up with.

U2 is the display driver IC, this is also loaded serially with information to what the displays show. It controls six digits of the display as well as the error code LEDs.

VR1 and the surrounding parts form a simple voltage regulator to supply a steady 5 VDC to the ICs in this circuit. By using this scheme, we can have a wide range of supply voltages, from 7 volts to 15 volts DC.

## **"THE RAMSEY LEARN AS YOU BUILD ASSEMBLY STRATEGY"**

Take a look at the parts layout diagram, there is quite a lot to the construction of the URC1. It's easier than it seems once you get going, and after you have placed a few of the "landmark" components. Other part's positions are referenced to them, and construction goes quite smoothly. This will help in relating from one part to another what specific holes a part may require on the board, and the part's orientation. In addition, we will discuss the purpose of most components or groups of components as we go along.

Be sure to read through all the steps, and check the boxes as you go to be sure you didn't miss any important steps. Most of the problems we find here at the factory are due to faulty assembly - no matter how experienced the builder may be - it's especially tough to tell a 30 year experienced Ham that he goofed! Before you run the circuit, check all diodes and polarized capacitors for proper orientation.

### ***Tips and Notes:***

Use a good soldering technique - let your soldering iron tip gently heat the traces to which you are soldering, heat both wires and pads simultaneously. Apply the solder on the iron and the pad when the pad is hot enough to melt the solder. The finished joint should look like a drop of water on paper, somewhat soaked in.

Parts are mounted on the top side of the board, which on this kit is the side marked TOP.

IC sockets - A good practice, but not necessary in digital or low frequency circuits such as this. This prevents the horror of desoldering a bad or incorrectly placed IC.

Part orientation - All parts in the kit are mounted at 90 degree angles to each other, meaning that all parts are either parallel or perpendicular to the board.

Part installation - when parts are installed, the part is placed flat to the board, and the leads are bent on the backside of the board to prevent the part from falling out before soldering. The part is then soldered securely to the board, and the remaining lead length is clipped off. Some parts may have body paint on their leads, preventing the solder from making a firm bond. In this case, lightly scrape the paint away to allow the solder to make contact with the wire.

## **RAMSEY URC1 PARTS LIST:**

### **SEMICONDUCTORS**

- 1 7805 5 volt power regulator (VR1)
- 1 145436 (or MC145436) 14 pin dip DTMF decoder IC (U5)
- 1 68HC705J2 20 pin dip pre-programmed microcontroller (white sticker marked URC-1) (U6)
- 1 MAX7219 24 pin dip 8 digit display driver (U2)
- 1 MAX500 quad serial digital to analog converter (U7)
- 2 74HC595 serial latched shift registers (U1,U3)
- 1 DS1267 - 10 dual 10K digitally controlled potentiometer (U4)
- 6 seven segment LED displays (DSP1,2,3,4,5,6)
- 2 Red LEDs (D2,6)
- 2 1N4002 black epoxy diodes (D9, D10)
- 1 2N3904 NPN type transistor (Q2)
- 1 221-334-211 PNP or equivalent transistor (Q1)

### **CAPACITORS**

- 5 .01uF disk ceramic capacitors (marked .01 or 103 or 10 nF) (C2,5,7,10,11)
- 1 .1uF disk ceramic capacitor (marked .1 or 104) (C8)
- 1 470pF disk ceramic capacitor (marked 470 or 471) (C9)
- 1 100uF to 220uF electrolytic capacitor (C15)
- 3 10uF electrolytic capacitors (C4,6,13)
- 1 47uF electrolytic capacitor (C14)

### **RESISTORS**

- 2 10K ohm (brown-black-orange) (R1,2)
- 4 47K ohm (yellow-violet-orange) (R4,5,6,7)
- 1 1M ohm (brown-black-green) (R3)

### **HARDWARE AND MISCELLANEOUS**

- 1 3.579 Mhz crystal (Marked 3.579 or 3.579264) (X1)
- 1 1/8" PC mounted minijack (J1)
- 1 Power jack (J2)
- 1 Set hardware for regulator (1 screw and 1 nut)
- 1 34 pin right angle connector (CON1)
- 1 13 pin right angle connector (CON2)
- 1 3.9VDC lithium backup battery (B1)
- 1 Main PC board
- 1 Display PC board
- 1 20 Pin IC socket
- 1 4 inches of #24 bus wire

## **CONSTRUCTION OF THE URC1:**

The first thing we will do with this kit is check all of our parts and pieces to make sure we have them all. Use the parts list and your layout diagram to do this. If there are any differences, make sure the schematic agrees with what you have, and also be aware of the tolerances parts have in a kit. Non-critical parts can vary quite a bit with almost no effect on kit operation. For example you may get 1uF capacitors in place of 10uF capacitors, or a 3.579 crystal in place of a 3.579545 crystal. No harm done as these will make no difference in kit operation. Note there are two boards in this kit, as we will start with the larger main board in our assembly. You may have to break apart the two boards depending on how they are shipped.

- 1. Orient the circuit board as shown in the parts layout diagram.
- 2. Install J1, the PC mounted 1/8" minijack. This is where you hook up the audio with the DTMF tones.
- 3. Install C14, a 47uF electrolytic capacitor. Electrolytic capacitors are polarized and must be installed correctly. They are usually marked with a black stripe and a ( - ) indicating their negative lead, while PC boards will usually indicate the ( + ) hole.

At this point you may wish to make the decision of whether or not to use IC sockets to mount your ICs. Though they will add to the cost of your kit, they will prevent the horror of soldering in ICs the wrong direction, or the inability to easily replace a bad IC yourself. If you are a confident good kit builder, you wont have to worry about this.

- 4. Install U7, the 4 channel digital to analog converter (MAX 500, 16 dip). Pay extra close attention to the orientation of this device and make sure it is installed in the same direction as in the parts layout diagram. Notice the part has a tab or dimple representing pin 1. Also note that most if not all of these components are static sensitive so if you want to be cautious, ground your body with a clip lead to a ground such as an oscilloscope chassis. Make sure and practice good soldering skills, and keep an eye out for solder bridges or cold joints as you go.
- 5. Install C6, a 10uF electrolytic capacitor. Make sure and check polarity before soldering!
- 6. Install R4, a 47K resistor (yellow-violet-orange).
- 7. Install the 20 pin IC socket where U6 is to go, the microcontroller IC with the sticker marked URC1. Gently insert the U6 into the socket noting where pin 1 is. Pay close attention to the orientation of the tab on this part.



- 8. Install U4, the dual digitally controlled potentiometer (marked DS1267). Pay close attention again to the orientation of this part. This part as you will notice controls the position of the wiper on a 10K pot, and has very good linearity.
- 9. Install U3, one of the 74HC595 serial shift registers. Each of these ICs control eight on/off outputs, and can be cascaded for up to 64 outputs on this kit. Check orientation.
- 10. Install U1, the other 74HC595 serial shift register. Again check the orientation of this device.
- 11. Install C2, a .01uF ceramic capacitor (marked .01, 10nF or 103). Notice that this type of capacitor has no polarity markings, and is not critical in installation.
- 12. Install C13, a 10uF electrolytic capacitor. Pay close attention to it's polarity unlike the ceramic capacitor.
- 13. Install C15, the larger 100uF to 220uF electrolytic capacitor. Check it's polarity before soldering. Electrolytic capacitors, if installed incorrectly have been known to operate poorly, get warm, and possibly even explode, so take caution when using these capacitors!
- 14. Install D9, one of the 1N4002 diodes. These diodes are used to "steer" the supply voltage to the microcontroller. During normal operation, these diodes "steer" the voltage away from trying to recharge B1, and during power down, they "steer" the battery towards the microcontroller, and away from the other parts to save on power. Notice the white band on the diode, this is the cathode end. Make sure it's in the same orientation as the parts layout diagram shows.
- 15. Install D10, the other 1N4002 diode. Pay close orientation to the orientation of the cathode (banded) end of the diode. These two diodes that you just installed cause the microcontroller to go into power down mode, thus preserving the memory so passwords and output options are not lost.
- 16. Install Q1, a PNP type transistor marked 221-334-211. Note where the lettering is, this is not the flat side, the side without the lettering is! (You can tell since the larger flat side does not have the lettering.)
- 17. Install B1, the 3.9V lithium battery. Note the case of this battery is positive, not ground and it fits in easily only one way.
- 18. Install R2, a 10K ohm resistor (brown-black-orange).
- 19. Install C8, a .1uF ceramic capacitor (marked .1 or 104). This causes the microcontroller to reset properly on power up.

- ❑ 20. Install C9, a 470pF ceramic capacitor (marked 470 or 471).
- ❑ 21. Install VR1, the 7805 regulator into the the three holes provided in the board. The metallic portion of the regulator should face towards the tabbed side of the board. Gently bend the regulator over until the hole in the tab lines up with the hole in the PC board. Install the provided screw and nut through the hole as shown, and tighten the nut until the regulator is snug to the board. Then solder the three leads securely to the board.
- ❑ 22. Install C7, a .01uF ceramic capacitor (marked .01, 103 or 10nF).
- ❑ 23. Install X1, the 3.579Mhz crystal (silver can). Note that there are three holes provided for this crystal since there are a couple of sizes of the metal cans available. Note how it is placed in relation to the silk screen on the board. Mount X1 as flush to the board as possible.
- ❑ 24. Install R3 a 1M ohm resistor (brown-black-green).

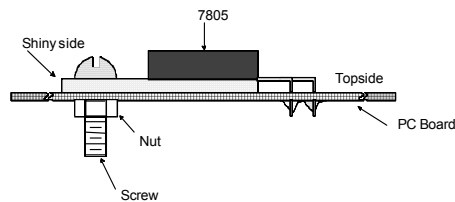

- ❑ 25. Install U5, the 145436 tone decoder IC (14 pin dip marked MC145436). Make sure and double check it's orientation before soldering. Also check for soldering mistakes before continuing.
- ❑ 26. Install C4, a 10uF electrolytic capacitor. Check polarity!
- ❑ 27. Install C5, a .01uF ceramic capacitor (marked .01, 103, or 10nF).
- ❑ 28. Install C10, a .01uF ceramic capacitor (marked .01, 103, or 10nF).
- ❑ 29. Install C11, a .01uF ceramic capacitor (marked .01, 103, or 10nF).
- ❑ 30. Install R1, a 10K resistor (brown-black-orange).
- ❑ 31. Install U2, the MAX7219 display driver (marked MAX7219). Check orientation and solder connections!
- ❑ 32. Install Q2, the NPN transistor marked 2N3904. Notice this time the lettered side is the flat side. Be sure and orient it the same as on the silk screen
- ❑ 33. Install R5, a 47K ohm resistor (yellow-violet-orange).
- ❑ 34. Install R6, another 47K ohm resistor (yellow-violet-orange).
- ❑ 35. Install R7, yet another 47K ohm resistor (yellow-violet-orange). The two preceding transistors and these three resistors assist the URC1 in

shutting itself down during a power down. They then allow the battery to take over memory retention of the data in the microcontroller.

Now here comes the fun! Take your time on the next stages as they can make or break your kit. Don't be a bozo and rush assembly to get it done, hook it up, and then destroy it. Play it smart and have patience and your kit will make you proud when it works the first time!

Locate the display board and orient it in the same direction in the parts layout diagram.

- 36. Install DSP1, one of the seven segment displays. Pay very close attention to where the decimal point is in reference to the notches on the board. Notice the decimal point faces the lower right of the board. This is where the soldering becomes difficult, the pads are very close to the traces, and solder bridges are easier to make. A small tipped soldering iron with a clean tip (wipe it often on a damp sponge) is required for best results. This is where patience really counts! Check and double check orientation before soldering, since desoldering on these fine traces will absolutely destroy them.
- 37. Hope you had a fun time doing the first display, now you get to do it five more times! Install DSP2 - DSP6 using the same technique as above. Start with DSP2 and in order end with DSP6. This prevents finger squeezing and much ranting and raving.
- 38. Install D6 one of the red LEDs. Notice the longer of the two leads on the LED, this is the lead that is installed towards the displays.
- 39. Install D2, the other red LED. Also notice that it is installed with the longer lead towards the displays.

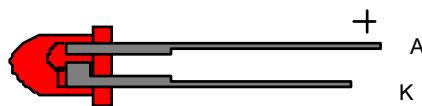

Locate the main board again and we will finish it up.

- ❑ 40. Install CON2, the thirteen pin connector. Insert it in the holes as shown in the diagram, making sure that the leads point to the back of the board.
- ❑ 41. Install CON1, the 34 pin connector using the same procedure as before. This connector may consist of two pieces, one 20 pin and one 14 pin connector. If so, place them together on the board to make one 34 pin connector. Check all of your solder joints on the two connectors before proceeding. Remember that you are responsible for damage that occurs to the output devices, so you don't want to goof up!

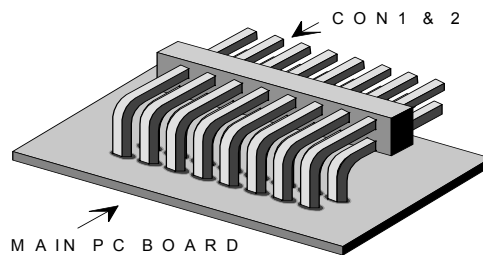

Now here comes some more fun! First check over all of your connections on the display board as well as the main board, you sure wouldn't want to come this far to make a mistake! Now it's time to join the two boards together.

- ❑ 42. Notice the holes in the main board and the display board where JMP-A and JMP-B are located. Cut the piece of thick bus wire in two. Using the two pieces of bus wire, install the jumpers to hold the main board and the display boards at 90 degree angles to each other. Notice how there are notches in the main board and display board to assist in aligning them. Use the notches to align the display board with the main board, note how the display board is mounted with the displays facing away from the main board.

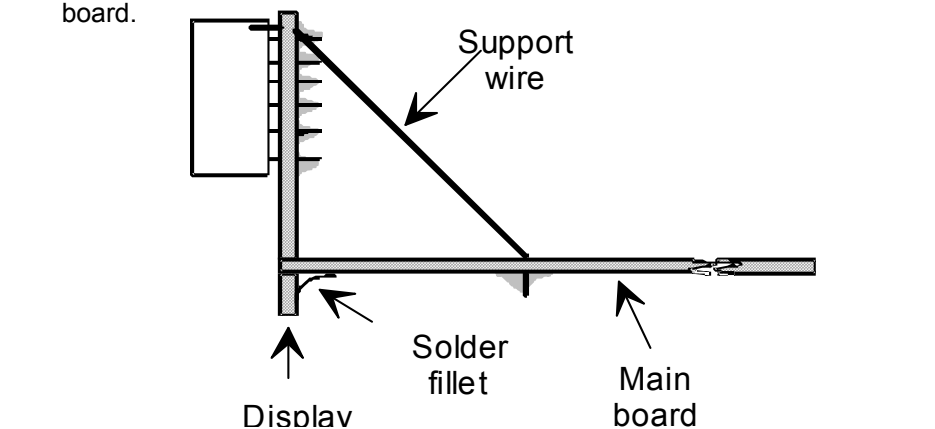

- 43. The display board mounts at a right angle to the main board with solder pads providing both mechanical support and electrical connection between the two boards. The display board is placed against the main board so that the solder pads on the display board line up with the solder pads on the main board. Solder the display board pads flush with the main board pads. Check to be sure the two boards are perpendicular and not tilted, then solder all remaining pads. Use enough solder to provide a good mechanical connection, but don't cause any solder bridges between adjacent pads.

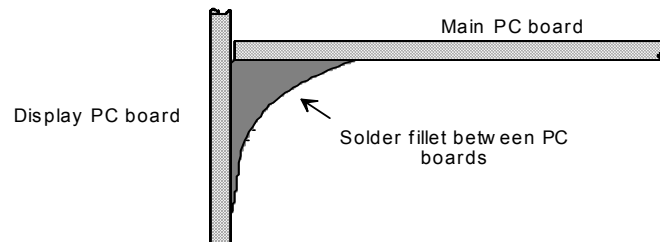

- 44. A last minute addition: Install J2, the DC power jack. This is where the 7-15VDC will be applied upon power up.

Congratulations you have just finished the entire URC1 kit! Now all that we have to do is some initial testing and setup.

### **INITIAL TESTING:**

To begin our initial tests, we need a few missing pieces to complete the whole remote control system. These are:

- A radio, or a DTMF dialer or generator, or a DTMF telephone with an audio tap (see hints on building an audio tap).
  - Suitable connectors for power, audio and outputs.
  - A 7-15 volt DC power supply or battery.
  - A multimeter or oscilloscope.
- 
- ❑ 1. Verify that all parts are mounted and soldered in the correct places, and there are no solder bridges or cold solder joints on both the main board and the display board.
  - ❑ 2. Connect the audio source with the DTMF tones to J1 of your kit.
  - ❑ 3. Apply power to your URC1. Make sure that the center connector of the jack you use is POSITIVE. On first time power up the memory is cleared out, and so are the passwords. Also a display test is performed, so the entire display should light for about one second before blanking. If the display never lights or is erratic, consult the trouble shooting section of this manual and unhook the power immediately.
  - ❑ 4. Generate an “\* M” or a \* 6 on the touch tone phone for the master password. The display should light up with zeros.
  - ❑ 5. Generate a “\*0” for oper and then 087 or “0TS” for testing. This mode sets all of your timers on, and all of the outputs vary so a change can be noticed. Notice that if this mode is performed during normal operation the memories are changed and not restored when finished. This mode also sets all of the displays on.
  - ❑ 6. Use an oscilloscope, multimeter, logic probe, or some other form of indication to verify that all of the outputs are varying, as well as independently from each other. The outputs should switch from 0 to +5 volts, the levels should vary from 0 to +5 volts, the resistance between the wiper and low or high side of the pots should vary from near zero ohms to 10K ohms. The timers should vary from near 5 volts to 0 volts.

If you have made it this far with your kit and have had no problems, you're all set to go! If not, consult the troubleshooting guide in the manual to determine the cause of the problem and how to go about solving it.

### **TROUBLESHOOTING TIPS:**

**PROBLEM:** None of the displays light, VR1 regulator gets hot fast.

**SOLUTION:** You likely have a short across the power supply or you have a component placed in the incorrect orientation. Check all of your parts to make sure they correlate with those in the parts layout diagram. Also check your power supply polarity to make sure that the polarity is correct.

**PROBLEM:** None of the displays light, but VR1 remains cool.

**SOLUTION:** Using an oscilloscope or a frequency counter, verify that there is a 3.579 Mhz signal on pin 10 of U5 and pin 1 of U6 of approximately .5 volts peak to peak or greater. If you cannot check this, check pin 9 of U6 for 4 to 5 volts DC. Also check pin 19 of U2 for 5 VDC. If not, check VR1 for 5 volts output with at least 7 volts input.

**PROBLEM:** Some displays and segments light, others do not when I run all eights into the unit.

**SOLUTION:** There is only two possibilities for this problem. First check with a magnifier to verify that there are no shorts or cold solder joints on the display board behind the displays. Also check the interface between the two boards to make sure everything has been done correctly. Second, you may have a faulty display. Since this is very unlikely, check all of your solder joints again to make sure they are OK. If everything is fine, then see the warranty section of the manual.

**PROBLEM:** Everything is OK, but no tones can be detected.

**SOLUTION:** Check around U4 and J1 for bad solder joints. Also make sure that your crystal is marked 3.579 and not some other number. Also check your audio connections and the audio level to the unit.

**PROBLEM:** Levels don't go all the way up to 5 volts.

**SOLUTION:** This was necessary on the kit to allow all 256 steps to be noticed. If a higher output voltage is required, remove D11 and put a jumper in it's place. Now you will notice that a value entered from 245 on up represents full scale.

**PROBLEM:** Outputs only go to half voltage, some outputs don't work at all, resistance values don't change.

**SOLUTION:** More than likely this is an assembly error, usually solder bridges or cold solder joints surrounding CON1 and CON2. A fine tip soldering iron and solder wick will help you to remedy these problems, as well as patience and good troubleshooting skills.

**PROBLEM:** The thing just doesn't work! It must be the engineer's fault!

**SOLUTION:** We make absolutely sure that our products work beyond expectations before the kits leave our doors. If you can't solve the problem, send in the kit, if it's our fault the fix charge is free. Read the warranty information in the back of the manual for more information.

### USING YOUR URC1

There is so many things you can do with a kit of this nature, that we will only go into some of the possibilities. Many more things can be done with it than what is being shown, just use some of the basic principles shown here and your imagination and you will be churning out the projects that will even impress the experts!

#### Connecting a relay to a switched output:

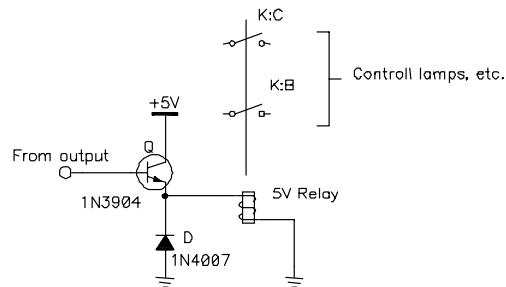

Once connected to the relay, the URC1 can turn a number of devices on and off, such as home security systems, lights, answering machine, lawn watering system, swimming pool filters, etc. Be sure the coil on the relay has a resistance of no less than 100 ohms to be safe. If it is less, use a transistor with a higher power dissipation rating.

#### Using a Level output as an isolated Variable Resistor:

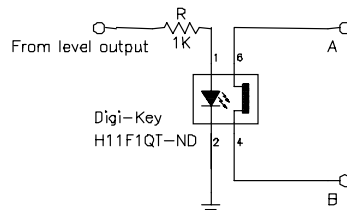

This is a simple, yet useful way of isolating the URC1 from the unit being controlled. This setup will work well for any circuit (within current limits) that requires a variable resistance. For example this can be used to control a form of squelch on a radio called level detection. This simple circuit can be used in



place of the pot presently in a circuit with this method of squelching. Also good in voltage divider networks, and current controls. Notice other versions of these opto-isolators can be used to isolate the switched outputs also.

The other method of squelch control uses the quieting phenomena during reception of a signal to open the squelch. When there is not a signal there is plenty of random noise received, especially high frequency noise. This high frequency noise is used to close the squelch when the quieting effect is not present. With this method all that is needed is the three pot connections on the URC1 in place of the pot that previously controlled the squelch. These variable pots can also replace the level detection method by tying the wiper output to the high output.

To use the variable pots:

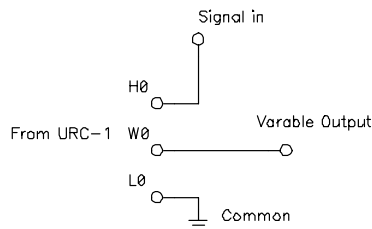

This is the simplest way of controlling signal levels such as volumes, voltages, powers, etc. Always tie the common ground of the URC1 to the common on the unit you are trying to control. If you are worried about the common on the unit to be controlled not being isolated, run the URC1 off of an isolated power supply. Using this method should protect the URC1 from damage from grounding errors. L0 does not have to be tied to common, but must not go lower in voltage than the common of your URC1.

To use a Level Output as a Variable Power Supply or Voltage Source:

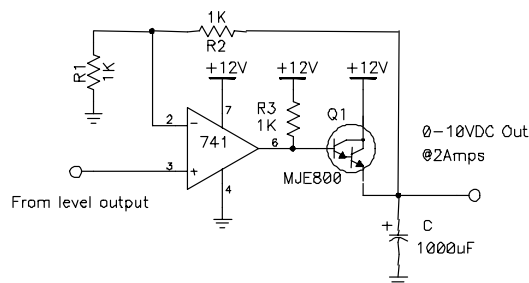

This configuration allows a user to adjust a 12VDC-18VDC unregulated power supply to a 0-10VDC regulated supply. The regulation in this case is limited to how well the URC1's regulator is operating. Parts can be modified in value to

change voltage output levels as well as current ratings. Note with larger currents that you should provide a heat sink on Q1. To change the maximum voltage output, use the formula:

$$V_{out} = 5 * (1 + R2/R1)$$

There are plenty of ways to use the outputs of the URC1 to control different circuits, devices, and run equipment. These basic ideas given will get you started on developing your own remote control system. If you want more ideas or more detail on how to hook up these circuits, consult some of the electronics magazines available at the supermarket, or go to your local library. These sources are usually loaded with great ideas for interfacing the types of output provided here with the external world!

#### Building a Telephone Audio Tap:

Through this method the user can tap the DTMF tone off of a telephone line. This is the simplest of methods to interface the URC1 to the telephone lines. Notice though you will need some sort of answering device such as a message machine to pick up the phone. If the phone is not off the hook, this circuit will not pick up any audio.

#### Inserting Audio output into the phone line:

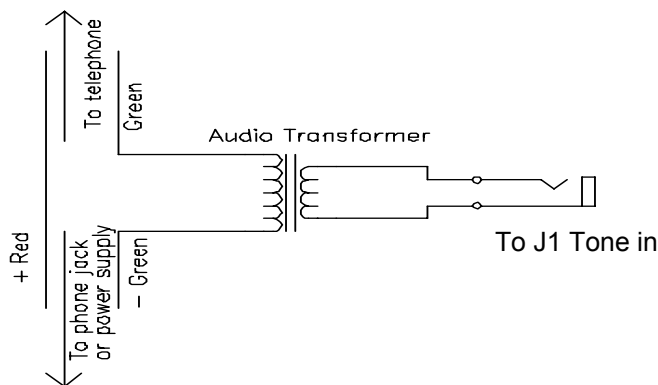

This is how you are able to insert the confirmation tones into the telephone line so that when you are dialing from a remote location you can hear the URC1 talk back to you, and let you know that a code was correctly received and processed. You may also receive tones as well with this circuit. Notice it is in parallel with the phone line instead of series like the previous circuit.

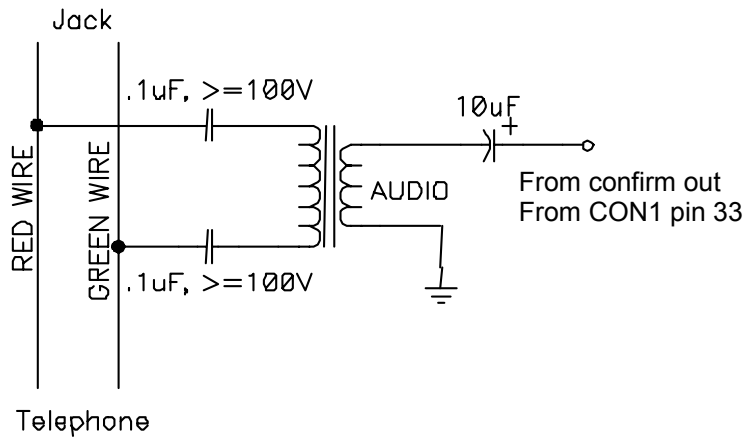

### **Setting up the URC1:**

These are some general ideas for setting up the URC1 for either a multiple user remote control, or a protected mode of operation. We will start from very first power up, all the way to leaving the URC1 to do it's stuff. If you are interested in more details about the codes used refer to the the section on URC1 command codes.

1. Power up and test the URC1 as instructed in the initial testing section of the manual.
2. Hook up any of the peripherals that you may want to control such as lamps, radios, alarm systems etc. Make sure commons on circuits are connected properly to the URC1.
3. Enter in as a master user using \*6. Use your tone generator to set the devices you want to exclude from the user, such as the alarm system. Use the control codes in the rear of the manual for instructions.
4. Set your initial values, check everything out for proper operation.
5. Set the user password, which is limited to three characters, and then the master password which is limited to four. Make sure and write these down. If you forget them, you have to disconnect the power and remove the battery to reset them.
6. Press \*3 to tell the URC-1 that you are finished. At this point the URC-1 will blank it's display, and wait for the password of a user or master to access it again. If a user is to access it, the items that you disabled by excluding them cannot be changed. Only the master can change them now.

**Charts and Diagrams:**

**Display Conventions:**

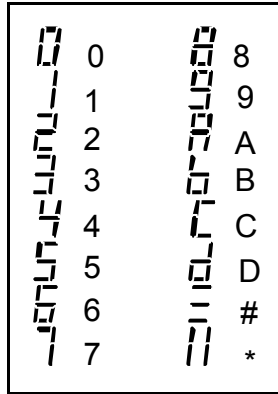

**Pinouts of CON2:**

| Pin # | Name | Description          |
|-------|------|----------------------|
| 1     | GND  | Ground               |
| 2     | GND  | Ground               |
| 3     | LDS  | Load Shift Registers |
| 5     | CLK  | Serial Clock         |
| 6     | GND  | Ground               |
| 7     | DATA | Serial Data          |
| 8     | GND  | Ground               |
| 9     | LDP  | Load Pots            |
| 10    | GND  | Ground               |
| 11    | COUT | Pots Serial Out      |
| 12    | QH'  | Shift Registers Out  |
| 13    | +5V  | +5V                  |
| 14    | +5V  | +5V                  |

**Note:** This jack is not used unless you plan on expanding your kit for more control pots and outputs.

This is a table showing the signal available at each pin of CON1, the access number for which the pin is accessed and changed, the group number for disabling and enabling, description, name, and range of output. "?" indicates a variable number.

| Pin # | Name  | Device # | Description | Access #     | Range            |
|-------|-------|----------|-------------|--------------|------------------|
| 1     | VoutD | 15       | Level 3     | *53???       | 0-5V, 256 steps  |
| 2     | VoutA | 12       | Level 0     | *50???       | 0-5V, 256 steps  |
| 3     | VoutC | 14       | Level 2     | *52???       | 0-5V, 256 steps  |
| 4     | VoutB | 13       | Level 1     | *51???       | 0-5V, 256 steps  |
| 5     | +5V   | -        | V source    | -            | 5V               |
| 6     | +12V  | -        | V source    | -            | 12V              |
| 7     | GND   | -        | Common      | -            | 0V               |
| 8     | T2    | 18       | Timer 2     | *T2??*??*    | 10mS to 40H      |
| 9     | T0    | 16       | Timer 0     | *T0??*??*    | 10mS to 40H      |
| 10    | T1    | 17       | Timer 1     | *T1??*??*    | 10mS to 40H      |
| 11    | W1    | 9        | Pot 1 Wiper | *21???       | 0-10K, 256 steps |
| 12    | H1    | 9        | Pot 1 High  | Not adjusted | 0-10K, 256 steps |
| 13    | L1    | 9        | Pot 1 Low   | Not adjusted | 0-10K, 256 steps |
| 14    | L0    | 8        | Pot 0 Low   | Not adjusted | 0-10K, 256 steps |
| 15    | H0    | 8        | Pot 0 High  | Not adjusted | 0-10K, 256 steps |
| 16    | W0    | 8        | Pot 0 Wiper | *20???       | 0-10K, 256 steps |
| 17    | GND   | -        | Common      | -            | 0V               |
| 18    | 1,7   | 1        | Output      | *617?        | 5V on off        |
| 19    | 0,7   | 0        | Output      | *607?        | 5V on off        |
| 20    | 1,6   | 1        | Output      | *616?        | 5V on off        |
| 21    | 0,6   | 0        | Output      | *606?        | 5V on off        |
| 22    | 1,5   | 1        | Output      | *615?        | 5V on off        |
| 23    | 0,5   | 0        | Output      | *605?        | 5V on off        |
| 24    | 1,4   | 1        | Output      | *614?        | 5V on off        |
| 25    | 0,4   | 0        | Output      | *604?        | 5V on off        |
| 26    | 1,3   | 1        | Output      | *613?        | 5V on off        |
| 27    | 0,3   | 0        | Output      | *603?        | 5V on off        |
| 28    | 1,2   | 1        | Output      | *612?        | 5V on off        |
| 29    | 0,2   | 0        | Output      | *602?        | 5V on off        |
| 30    | 1,1   | 1        | Output      | *611?        | 5V on off        |
| 31    | 0,1   | 0        | Output      | *601?        | 5V on off        |
| 32    | 1,0   | 1        | Output      | *610?        | 5V on off        |
| 33    | Tone  | -        | Tone out    | *600?        | Confirm Out      |
| 34    | GND   | -        | Common      | -            | 0V               |

Note: Pin 33 can be accessed as an output, but its value will change every time a code is received and a tone is sent, therefore it is not recommended to be used as an output other than for generating tones.

### **URC1 Control Codes:**

The codes on the URC1 are very simple to use as well as comprehensive. Codes have been laid out so that the letters on a touch tone phone represent the action that you desire. Note that all codes begin with an asterisk. This was done to prevent the normal dialing of a phone or some other device from accessing the unit.

[ ] indicates not required or variable length.

{ } indicates one character

#### **To access the URC1:**

For master access: \*M[Password]\* or \*6[Password]\*

Where master password length is at most 4 characters.

This code replies with two long tones indicating "M"

For user access: \*U[Password]\* or \*8[Password]\*

Where user password length is at most 3 characters.

This code replies with two shorts and a Long to indicate "U"

Ex: \*M123\*

Note that if no password has been set for either, the last asterisk is left off.

#### **To set the password:**

To set the master password: \*PM[Password]\* or \*76[Password]\*

Where maximum password length is 4 characters. Entering no characters for password disables the password.

This code replies with a short then long tone to indicate "A" for acknowledge.

To set the user password: \*PU[Password]\* or \*78[Password]\*

Where maximum password length is 3 characters. Entering no characters for password disables the password.

This code replies with a short then long tone to indicate "A" for acknowledge.

Note that you must be entered as a master to change these.

#### **To set an output on or off:**

To turn an output on:

\*0{output set #}{Output #}1 or \*6{output set #}{Output #}1

This code replies with a short then long tone to indicate "A" for acknowledge.

To turn an output off:

\*0{output set #}{Output #}0 or \*6{output set #}{Output #}0

This code replies with a short then long tone to indicate "A" for acknowledge.

Note that the last one or zero denotes on and off respectfully. Note there is only eight output sets (0-7) and eight outputs per set (0-7). Any number entered over seven causes an error and the command is aborted. Also note that output 0,0 is used as a confirm tone output. In other words don't use it as an output unless it is to generate a tone.

#### **To set a Level:**

To set directly: \*L{Level #}[0-255] or \*5{Level #}[0-255]

Using this method you can quickly set any level you desire. For example if you want 2.5 volts out, enter 127 for the level, and if you want the full 5 volts enter 255. Three numbers must be entered for the level.

This code replies with a short then long tone to indicate "A" for acknowledge.

1/4 scale example on level output 0: \*50064

Where 5 is the command code, 0 is the device code, and 064 is the value.

To vary the level down: \*L{Level #}\* or \*5{Level #}\*

Press and hold the last asterisk to keep decreasing the level. The level stops decreasing at a value of zero. When it has reached zero, the URC1 replies with a short then long tone to indicate "A" for acknowledge.

To vary the level up: \*L{Level #}# or \*5{Level #}#

Press and hold the pound sign to keep increasing the level. The level stops at a value of 255. When it has reached 255, the URC1 replies with a short then long tone to indicate "A" for acknowledge.

Note that there is only four level outputs (0-3), so any value over 3 will cause an error and the command will be aborted. Also any value over 255 in the level code will do the same.

#### **To set a Control Pot:**

This method is almost identical to setting the levels except for the command code.

To set directly: \*C{Level #}[0-255] or \*2{Level #}[0-255]

Using this method you can quickly set any resistance you desire. For example if you want 5K ohms at the wiper, enter 127 for the resistance, and if you want the full 10K ohms, enter 255. Three numbers must be entered for the level.

The URC1 replies with a short then long tone to indicate "A" for acknowledge.

3/4 scale example on resistor 1: \*21192

Where 2 is the command code, 1 is the device code, and 192 is the value.

To vary the resistance down:                    \*C{Level #}\* or \*2{Level #}  
Press and hold the last asterisk to keep decreasing the resistance. The  
resistance stops decreasing at a value of zero (near zero ohms).  
The URC1 replies with a short then long tone when at zero to indicate "A" for  
acknowledge.

To vary the resistance up:                    \*C{Level #}# or \*2{Level #}  
Press and hold the pound sign to keep increasing the resistance. The  
resistance stops at a value of 255 (10K ohms). The URC1 replies with a short  
then long tone at a value of 255 to indicate "A" for acknowledge.

Note that there are only four pot controls (0-3) possible, though only two  
provided on this kit, so any value over 3 will cause an error and the command  
will be aborted. Also any value over 255 in the pot value code will do the  
same.

#### **To set a Timer:**

\*T{Timer #}tt[\*][ss][\*][mm][\*][hh] tt[\*][ss][\*][mm][\*][hh] or  
\*8{Timer #}tt[\*][ss][\*][mm][\*][hh] tt[\*][ss][\*][mm][\*][hh]  
(.....Time off.....) (.....Time on.....)

tt indicates hundredths of a second, ss indicates seconds, mm indicates  
minutes, and hh indicates hours. Where Timer # is 0-2; tt, ss, mm, and hh are  
values from 00-99. Any value over these will cause an error and the command  
will be aborted. Notice that pressing an asterisk at the end of tt, ss, or mm will  
end the command for that part of the timing cycle. For example pressing:

\*8201\*01\*

will set timer 2 on for 10mS and off for 10mS. To set on and off for 1 hour  
press:

\*82000000100000001

Note there are no asterisks at the end of each time. This makes entering  
easier since all of the times are entered anyhow. The only time you need to  
press the ending asterisk is when you plan on not entering the hours.

After each time is set, the URC1 replies with a short then long tone to indicate  
"A" for acknowledge. When you are done entering the URC1 replies with a  
short then long tone to indicate "A" for acknowledge so that two "A"s are sent  
upon completion. Try it out to see how it works

#### Some more examples:

To set timer2 on for 120mS and off for 12 hours, 35 minutes:

\*820000351212\*



To set timer1 on for 35 hours 12seconds, and off fore 10mS:

\*8101\*00120035

Hook up some LEDs as shown with series resistors to the timer outputs, and then experiment a bit to see how this method works. Have patience as these codes take a little time to get used to.

From timer or output

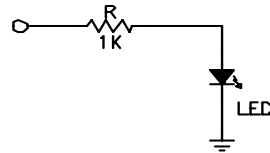

### For the master user to exclude devices from the user:

To exclude:

\*X[00-18]1

To include:

\*X[00-18]0

The access number is found on the chart with the pinouts of CON1. Since there is only 19 devices (0-18), any number over 18 is rejected and the command is aborted.

The URC1 replies with a short then long tone to indicate "A" for acknowledge.

Example to turn timer 2 off from the user:

\*9181

Where 9 is the control code, 18 is the device number, and 1 disables the device from the user changing it. Notice of course that you must be entered as a master user to change these settings. Entering a 1 disables, and a 0 enables.

### Special codes:

#### Resetting the entire unit:

Reset the display only:

\*0000

Clear all:

\*0CAL or \*0252

Note that this command can be dangerous as it clears out everything, passwords as well as output settings. This command will only work if you're entered as a master user.  
The URC1 replies with a short then long tone to indicate "A" for acknowledge.

#### **Testing the URC1:**

\*00TS or \*0087

This command is also dangerous, but it does not destroy the passwords. It only alters the outputs. This command is only meant to be used for testing and identification of problems. This code is only available to the master user.  
The URC1 replies with a short then long tone to indicate "A" for acknowledge and then begins testing.

#### **Done Accessing the URC1:**

\*D or \*3

This command blanks out the display to save on power, and exits the user mode. The URC1 then waits for the next valid password to light the displays and begin work again.  
The URC1 replies with two longs then a short tone to indicate "G" for goodbye.

#### **Other tones:**

The URC1 will return a long then short tone to indicate an error in entry such as password protected, numbers that are too large, and accidental keystrokes during entry of a code. Otherwise the URC1 just ignores you if there is no valid code entered.

**Notes and Passwords:**

| Password | Master/User | Date   | URC # |
|----------|-------------|--------|-------|
| 1234     | M           | 6-5-94 | 1     |
|          |             |        |       |
|          |             |        |       |
|          |             |        |       |
|          |             |        |       |
|          |             |        |       |
|          |             |        |       |
|          |             |        |       |
|          |             |        |       |
|          |             |        |       |
|          |             |        |       |
|          |             |        |       |
|          |             |        |       |
|          |             |        |       |

| Device Name | User Mask # | Code for Access | Notes              |
|-------------|-------------|-----------------|--------------------|
| Lamp        | 0           | *601?           | ? indicates 1 or 0 |
|             |             |                 |                    |
|             |             |                 |                    |
|             |             |                 |                    |
|             |             |                 |                    |
|             |             |                 |                    |
|             |             |                 |                    |
|             |             |                 |                    |
|             |             |                 |                    |
|             |             |                 |                    |
|             |             |                 |                    |
|             |             |                 |                    |
|             |             |                 |                    |
|             |             |                 |                    |
|             |             |                 |                    |

### **Connector considerations :**

Upon design of this kit we determined that we would use standard size connectors for interface. We ended up using connector cables from PCs to determine what sizes you may have laying around at home, or available at the local electronics store. Connector 1 uses a 34 pin connector, which is common on most hard drives, and connector 2 uses a 14 pin connector which was a common size in the stores near here.

To connect these up you can bring the wires of the ribbon cable out to a connector board that you devise yourself, or add on some wire to run directly to the device you wish to control. Use the look up tables on pages 20 and 21 to determine what wires go where. Note that pin 1 and wire one are marked so that you don't get confused.

### **Expanding Notes:**

If you decide to expand your URC1 to take full advantage of the number of outputs it may control, notice how almost all of the chips in this kit are serially accessed. They all work in much the same way as a serial latching shift register, so all that needs to be done is to cascade the devices. (We will leave this up to you to figure out and experiment with). Note that U1 and U3 are already in the cascaded form (you can use their example to expand the number of outputs). If you don't feel too confident in doing it yourself, we will be coming out with an expansion kit in the near future.

# URC-1 PARTS LAYOUT DIAGRAM

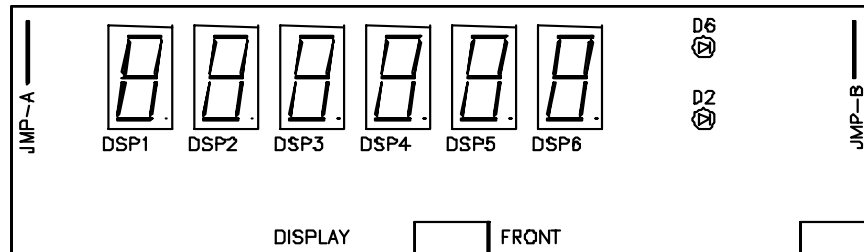
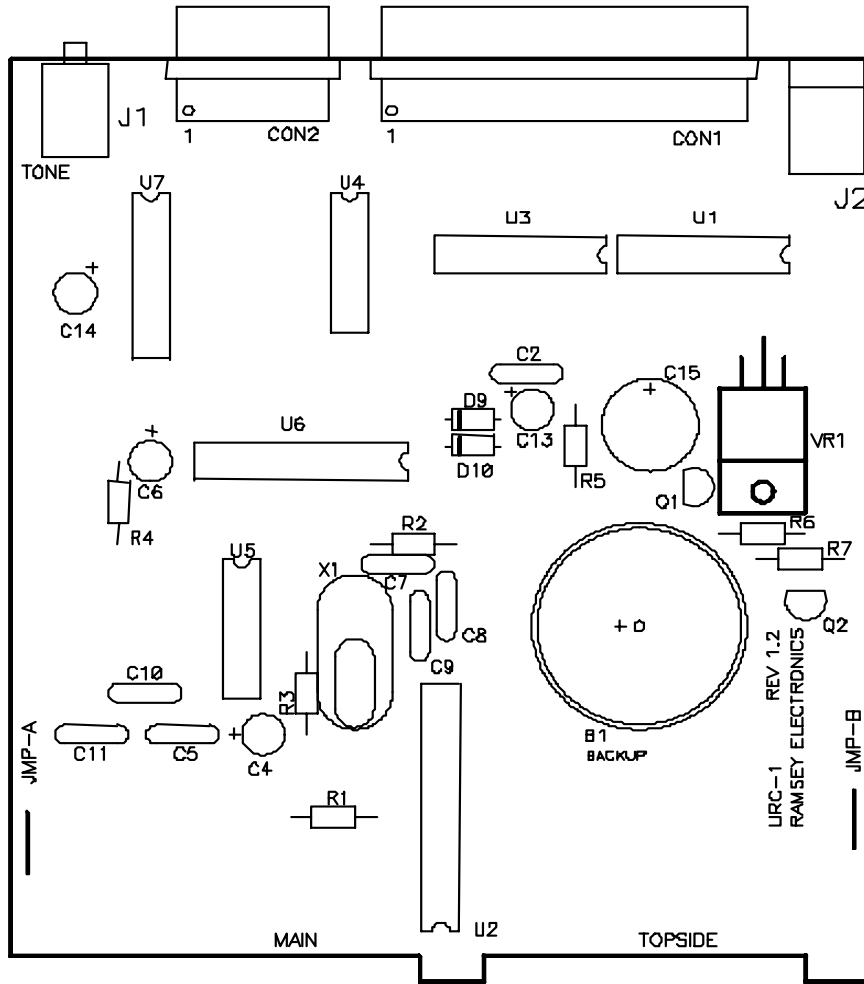

## **The Ramsey Kit Warranty**

**Please read carefully BEFORE calling or writing in about your kit. Most problems can be solved without contacting the factory.**

Notice that this is not a "fine print" warranty. We want you to understand your rights and ours to! All Ramsey kits will work if assembled properly. The very fact that your kit includes this new manual is your assurance that a team of knowledgeable people have field-tested several "copies" of this kit straight from the Ramsey Inventory. If you need help, please read through your manual carefully, all information required to properly build and test your kit is contained within the pages!

**1. DEFECTIVE PARTS:** It's always easy to blame a part for a problem in your kit. Before you conclude that a part may be bad, thoroughly check your work. Today's semiconductors and passive components have reached incredibly high reliability levels, and it's sad to say that our human construction skills have not! But on rare occasion a sour component can slip through. All our kit parts carry the Ramsey Electronics Warranty that they are free from defects for a full ninety (90) days from the date of purchase. Defective parts will be replaced promptly at our expense. If you suspect any part to be defective, please mail it to our factory for testing and replacement. Please send only the defective part(s), not the entire kit. The part(s) MUST be returned to us in suitable condition for testing. Please be aware that testing can usually determine if the part was truly defective or damaged by assembly or usage. Don't be afraid of telling us that you 'blew-it', we're all human and in most cases, replacement parts are very reasonably priced.

**2. MISSING PARTS:** Before assuming a part value is incorrect, check the parts listing carefully to see if it is a critical value such as a specific coil or IC, or whether a RANGE of values is suitable (such as "100 to 500 uF"). Often times, common sense will solve a mysterious missing part problem. If you're missing five 10K ohm resistors and received five extra 1K resistors, you can pretty much be assured that the '1K ohm' resistors are actually the 'missing' 10 K parts ("Hum-m-m, I guess the 'red' band really does look orange!") Ramsey Electronics project kits are packed with pride in the USA. If you believe we packed an incorrect part or omitted a part clearly indicated in your assembly manual as supplied with the basic kit by Ramsey, please write or call us with information on the part you need and proof of kit purchase

### **3. FACTORY REPAIR OF ASSEMBLED KITS:**

To qualify for Ramsey Electronics factory repair, kits MUST:

1. NOT be assembled with acid core solder or flux.
2. NOT be modified in any manner.
3. BE returned in fully-assembled form, not partially assembled.
4. BE accompanied by the proper repair fee. No repair will be undertaken until we have received the MINIMUM repair fee (1/2 hour labor) of \$18.00, or authorization to charge it to your credit card account.
5. INCLUDE a description of the problem and legible return address. DO NOT send a separate letter; include all correspondence with the unit. Please do not include your own hardware such as non-Ramsey cabinets, knobs, cables, external battery packs and the like. Ramsey Electronics, Inc., reserves the right to refuse repair on ANY item in which we find excessive problems or damage due to construction methods. To assist customers in such situations, Ramsey Electronics, Inc., reserves the right to solve their needs on a case-by-case basis.

The repair is \$36.00 per hour, regardless of the cost of the kit. Please understand that our technicians are not volunteers and that set-up, testing, diagnosis, repair and repacking and paperwork can take nearly an hour of paid employee time on even a simple kit. Of course, if we find that a part was defective in manufacture, there will be no charge to repair your kit (But please realize that our technicians know the difference between a defective part and parts burned out or damaged through improper use or assembly).

**4. REFUNDS:** You are given ten (10) days to examine our products. If you are not satisfied, you may return your unassembled kit with all the parts and instructions and proof of purchase to the factory for a full refund. The return package should be packed securely. Insurance is recommended. Please do not cause needless delays, read all information carefully.

**URC1 UNIVERSAL REMOTE CONTROL  
Quick Reference Page Guide**

Introduction to the URC1..... 4  
Parts list..... 7  
URC1 Assembly instructions..... 8  
Initial testing..... 14  
Troubleshooting tips..... 15  
Setup ..... 19  
Notes and passwords ..... 27  
Connector Considerations..... 28  
Schematic diagram ..... 29  
Parts Layout diagram..... 30  
Ramsey kit warranty ..... 31

**REQUIRED TOOLS**

- Soldering Iron (Radio Shack #RS64-2072)
- Thin Rosin Core Solder (RS64-025)
- Needle Nose Pliers (RS64-1844)
- Small Diagonal Cutters (RS64-1845)
- <OR> Complete Soldering Tool Set (RS64-2801)

**TOTAL SOLDER POINTS**  
**324**

**ESTIMATED ASSEMBLY  
TIME**

**Beginner ..... 8.5 hrs**  
**Intermediate..... 5.5 hrs**  
**Advanced ..... 4.0 hrs**

**ADDITIONAL SUGGESTED ITEMS**

- Soldering Iron Holder/Cleaner (RS64-2078)
- Holder for PC Board/Parts (RS64-2094)
- Desoldering Braid (RS-2090)

Price: \$5.00

Ramsey Publication No. MURC1

Assembly and Instruction manual for:

***RAMSEY MODEL NO. URC1 UNIVERSAL  
REMOTE CONTROL KIT***



**RAMSEY ELECTRONICS, INC.**  
**793 Canning Parkway**  
**Victor, New York 14564**  
**Phone (716) 924-4560**  
**Fax (716) 924-4555**  
**www.ramseykits.com**



Printed on recycled paper

## Free Manuals Download Website

<http://myh66.com>

<http://usermanuals.us>

<http://www.somanuals.com>

<http://www.4manuals.cc>

<http://www.manual-lib.com>

<http://www.404manual.com>

<http://www.luxmanual.com>

<http://aubethermostatmanual.com>

Golf course search by state

<http://golfingnear.com>

Email search by domain

<http://emailbydomain.com>

Auto manuals search

<http://auto.somanuals.com>

TV manuals search

<http://tv.somanuals.com>