



Now Available in
Close Focus and
Subzero Models

RAYNGER MX SERIES

The Professional's Choice

The new Raynger MX family of handheld, infrared thermometers takes noncontact temperature measurement technology into the future. Designed for ease-of-use, unmatched performance, and new laser technology, the MX is the professional's tool of choice.

Enhanced Features and Accuracy

The MX features an optically matched coaxial laser sighting system, that precisely and accurately outlines the target measurement area. Improved optics (D:S 60:1) allow temperature measurement from any distance, and the bar graph display automatically charts the last 10 temperature points using maximum and minimum temperature values to establish the range. The locking trigger allows continuous temperature monitoring.

The MX2 is the standard model. Just point, shoot, and read. The MX4 is the high-performance model that accepts K & J thermocouples, thermistor (NTC), power input, and allows for data output. The MX4+ package includes Windows™-compatible data management software, a thermocouple K probe, an RS232 computer cable, and a plug-in power supply. A useful table of 30 preset material emissivity listings is easily accessed on both the MX4 and MX4+. Simply scroll to locate the correct material.

Now two new MX models are available. The MXSZ (Subzero) and MXCF (Close Focus) special purpose models are designed for specialized applications requiring measurement of very low temperature targets or extremely small target areas. Both MXSZ and MXCF feature Raytek's advanced optically matched coaxial laser sighting system and are available in the MX2, MX4 and MX4+ configurations.

Software

With Raytek graphing software, you can use your computer to organize, display, and print temperature and time data. The software also includes the ability to store data points, continuous or manual single-point recording, programmable time intervals, temperature scales and limits, built-in material table of emissivity values, customizable log locations, and displays both contact and infrared temperatures.



MX4+ Package includes: Windows-compatible data management software • thermocouple K probe • RS232 computer cable • plug-in power supply.

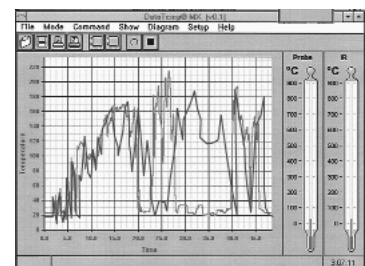

Windows-compatible MX4+ software graphs both contact and noncontact temperature points.

RAYNGER MX PORTABLE NONCONTACT THERMOMETERS

FEATURES

	MX2	MX4	MX4+
Adjustable emissivity	✓	✓	✓
On-board emissivity table	-	✓	✓
*16-point laser circle spot; meets IEC Class 2 & FDA Class II requirements	✓	✓	✓
*Single Laser Class III	✓	-	-
Audible/visible High alarm	✓	✓	✓
Audible/visible Low alarm	-	✓	✓
MAX and MIN temperature	✓	✓	✓
DIF and AVG temperature	-	✓	✓
Bar graph display	✓	✓	✓
Data output: RS232 or 1 mV per degree (°C or °F)	-	✓	✓
100 points of data logging	-	✓	✓
Windows-compatible	-	-	✓
Data Graphing Software	-	-	✓
Power Supply (110 or 220V), RS232 Computer Cable, 1.5 m (60 in), K thermocouple probe	-	-	✓

*MX2 available with either 16-point class II, or single point class III laser sighting system.

OPTIONS / ACCESSORIES

- Windows-based Data Graphing Software*
- RS232 computer cable*
- Thermocouple K probe*
- Plug-in Power Supply (110 or 220V)*
- Thermistor (NTC) probe
- Portable thermal printer
- Calibration Certification
- Soft pouch

*Standard with Raynger MX4+

SPECIFICATIONS

Temperature range	-30 to 900°C (-25 to 1600°F), MX2, MX4, MXCF -50 to 500°C (-58 to 932°F), MXSZ
Accuracy*	±1% of reading or ±1°C (±2°F), whichever is greater
Repeatability*	±0.5% of reading or ±1°C (±2°F), whichever is greater
Response time	(95%) 250 mSec
Spectral response	8 to 14 μm, thermopile detector
Display resolution	tenth degree reading up to 900°C (0.2°F to 999.8°F)
Ambient operating range	0 to 50°C (32 to 120°F)
Relative humidity	10-95% RH noncondensing @ up to 30°C (86°F)
Storage temperature	-30 to 50°C (-25 to 122°F) without battery
Power	2 AA batteries, DC power for MX4 and MX4+
Tripod mount	1/4-20 UNC
Dimensions	200 x 170 x 50 mm (7.9 x 6.7 x 2 inches)
Weight	480 g (1 lb. 6 oz)

*only at 23°C (73°F)

Target Spot Sizes and Distances

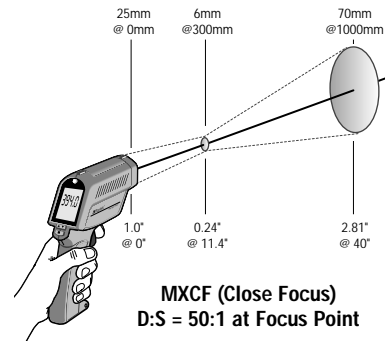
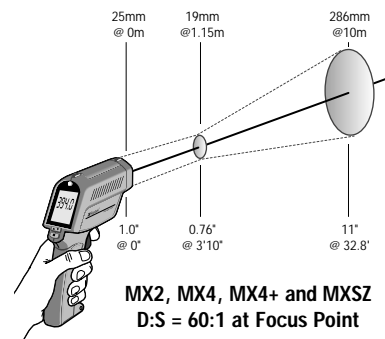

APPLICATIONS

The rugged, ergonomic MX has many uses:

- check for hot spots in electrical panels, circuit breakers, generators, and gearboxes
- monitor supply and return registers, air stratification, and duct leakage
- monitor temperatures of gasoline and diesel engine cylinders and railroad axles and bearings
- food preparation and storage
- Industrial predictive and preventative maintenance.
- Checking for icing and deicing on planes and asphalt
- Checking for depleted refrigeration media
- Cold storage and walk-in refrigeration applications
- Frozen food safety and processing
- ISO 9000 proactive maintenance programs
- Checking for bearing failures and motor misalignment
- Power distribution trouble shooting
- Electrical bench work in the shop or lab

For Sales and Ordering Contact:

WATLOW
5710 Kenosha Street
Richmond, Illinois 60071 USA
Phone: +1 (815) 678-2211
FAX: +1 (815) 678-3961
Internet: www.watlow.com
e-mail: info@watlow.com

Your Authorized Watlow Distributor Is:

For Service and Warranty Contact:

Raytek®

Worldwide Headquarters
Raytek Corporation
Santa Cruz, CA USA
Tel: 1 831 458 1110
800 866 5478 (U.S. and Canada only)
Fax: 1 831 425 4561
www.raytek.com



Raytek, the Raytek logo, and Thermalert are registered trademarks of Raytek Corporation.
©2001 Raytek Corporation, Printed in USA, 3/01 Rev. A
Specifications subject to change without notice. 3-1022

RIC-MX-0401

Free Manuals Download Website

<http://myh66.com>

<http://usermanuals.us>

<http://www.somanuals.com>

<http://www.4manuals.cc>

<http://www.manual-lib.com>

<http://www.404manual.com>

<http://www.luxmanual.com>

<http://aubethermostatmanual.com>

Golf course search by state

<http://golfingnear.com>

Email search by domain

<http://emailbydomain.com>

Auto manuals search

<http://auto.somanuals.com>

TV manuals search

<http://tv.somanuals.com>