

# INSTALLATION AND OPERATING INSTRUCTIONS

Models 090A, 135A, 195A  
Type WH

## ECONOPAK WATER HEATERS



### FOR YOUR SAFETY

Do not store or use gasoline or other flammable vapors and liquids or other combustible materials in the vicinity of this or any other appliance. To do so may result in an explosion or fire.

**WARNING:** Improper installation, adjustment, alteration, service or maintenance can cause property damage, personal injury or loss of life. Refer to this manual. Installation and service must be performed by a qualified installer, service agency or the gas supplier.

### FOR YOUR SAFETY

#### WHAT TO DO IF YOU SMELL GAS

- \*Do not try to light any appliance.
- \*Do not touch any electrical switch; do not use any phone in your building.
- \*Immediately call your gas supplier from a neighbor's phone. Follow the gas supplier's instructions.
- \*If you cannot reach your gas supplier, call the fire department.

This manual should be maintained in legible condition and kept adjacent to the heater or kept in a safe place for future reference.



**Raypak**<sup>®</sup>  
A Rheem<sup>®</sup> Company

## Contents

<b>3</b>	<b>1. RECEIVING EQUIPMENT</b>
<b>3</b>	<b>2. GENERAL SPECIFICATIONS AND DIMENSIONS</b>
4	General Safety Precautions
<b>6</b>	<b>3. INSTALLATION PROCEDURES</b>
6	- Code Requirements
6	- Mounting Base
6	- Clearance Requirements
6	- Combustion/Ventilation Air
7	- Venting Connections
8	- Common Vents
9	- Gas Supply Connections
10	- Water Connections & System Piping
11	- Electrical Wiring
12	- Wiring Diagrams
<b>13</b>	<b>4. SERVICING PROCECURES</b>
13	- General Locations of Controls
13	- Sequence of Operation
14	- Start Up Procedures
17	- Inspection Procedures
18	- Repair Section
<b>20</b>	<b>5. TROUBLE SHOOTING GUIDE</b>
22	- Adjustments/Replacements of Components
<b>23</b>	<b>6. REPLACEMENT PARTS LIST</b>

These instructions are provided to assure the proper installation and operation of Raypak water heaters. Should questions arise regarding the specifications, installation, operation or servicing of these water heaters, we suggest that the local Sales representative or the factory be consulted.

## 1. RECEIVING EQUIPMENT

On receipt of your equipment it is suggested that you visually check for external damage to the carton. If the carton is damaged, it is suggested that a note be made on the Bill of Lading when signing for equipment. Remove the heater from the carton and if it is damaged **report the damage to the carrier immediately**. Be sure that you receive the number of packages indicated on the Bill of Lading. **Claims for shortages and damages must be filed with carrier by consignee.**

Purchased parts are subject to replacement only under the manufacturer's warranty. Debits for defective replacement parts will not be accepted and defective parts will be replaced in kind only per our standard warranties.

When ordering parts, you must specify Model and Serial Number of the heater. When ordering under warranty conditions, you must also specify date of installation.

**Raypak recommends that this manual be reviewed thoroughly before installing your Raypak Heater. If there are any questions which this manual does not answer, please contact your local Raypak representative.**

## 2. GENERAL SPECIFICATIONS

The Raypak water heaters are design certified by the American Gas Association, and tested under the requirements of the American National Standard, **ANSI Z21.10.3**. Each heater has been constructed and pressure tested in accordance with the requirements of Section IV of the American Society of Mechanical Engineers Code, and factory fire tested.

The heaters are designed for indoor installation with a built-in draft hood, and a built-in sub-base for combustible flooring. Models are available with standing pilot, or with intermittent ignition device (I.I.D). The heaters are equipped with the following components: water circulation pump, pressure relief valve, manual reset high limit switch, fast response temperature sensor, 40 VA transformer, vent thermal switch, flame roll-out switch, and redundant combination gas valve. A tankstat is supplied loose for installation in the field.

## SPECIFICATIONS AND DIMENSIONS

MODEL	INPUT MBH	RECOVERY GPH	TANK GAL.*	PIPING CONNECTIONS		A	B	K VENT DIA.
				WATER NPT.	GAS NPT.			
WH-0090	90	90	80	1"	1/2"	11"	5-3/4"	5"
WH-0135	135	132	80	1-1/4"	1/2"	18"	6-1/4"	6"
WH-0195	195	192	80	1-1/4"	1/2"	18"	6-1/4"	7"

\*May be used with other tank size capacity.

Note: Recovery GPH based on Manufacturer's rating.

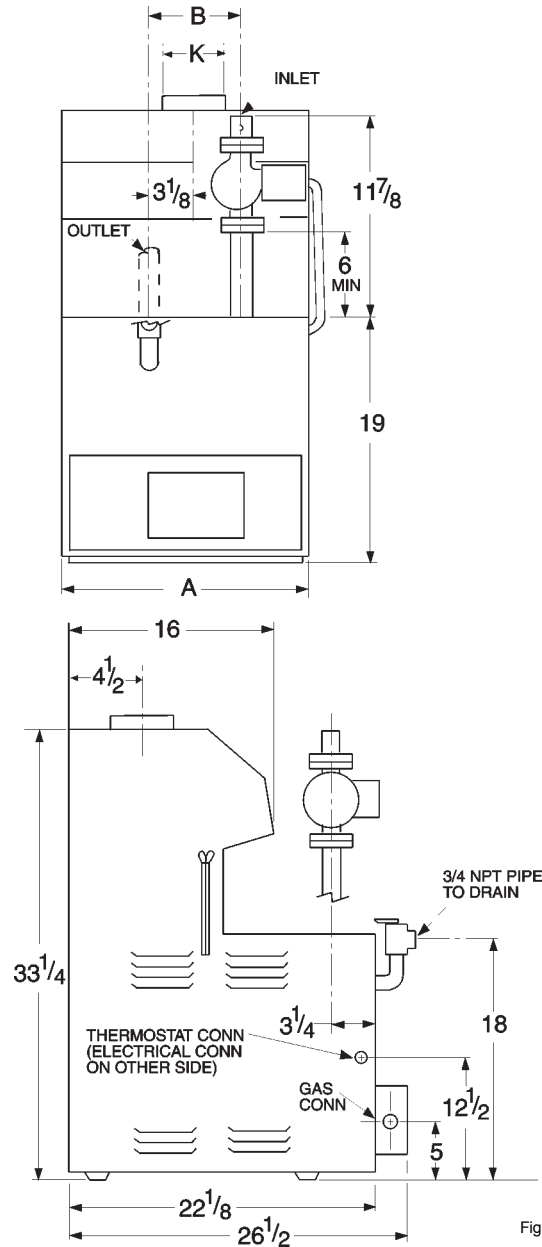

Fig. #8978.5.1

# ⚠ General Safety Precautions

Be sure to read and understand the entire Instruction Manual before attempting to install or operate this water heater. Pay particular attention to the following general Safety Precautions. Failure to follow these warnings could result in a fire or explosion, causing property damage, bodily injury or death. Should you have any problems understanding the instructions in this manual, STOP, and get help from a qualified installer or service technician or the gas supplier.

## ⚠ WARNING

Gasoline, as well as other flammable materials and liquids (adhesives, solvents, etc.), and the vapors they produce, are extremely dangerous. DO NOT handle, use or store gasoline or other flammable or combustible materials anywhere near or in the vicinity of a water heater. Be sure to read and follow the warning label pictured below and other labels on the water heater, as well as the warnings printed in this manual. Failure to do so can result in property damage, bodily injury, or death.

## ⚠ DANGER

Failure to install the draft hood and properly vent the water heater to the outdoors as outlined in the Venting Section of this manual can result in unsafe operation of the water heater. To avoid the risk of fire, explosion, or asphyxiation from carbon monoxide, never operate this water heater unless it is properly vented and has an adequate air supply for proper operation. Be sure to inspect the vent system for proper installation at initial start-up; and at least annually thereafter. Refer to Maintenance section of this manual for more information regarding vent system inspections.

## ⚠ DANGER



⚠ Vapors from flammable liquids will explode and catch fire causing death or severe burns.

Do not use or store flammable products such as gasoline solvents or adhesives in the same room or area near the water heater.

Keep flammable products:

1. far away from heater,
2. in approved containers,
3. tightly closed and
4. out of childrens reach.

Installation:

Do not install water heater where flammable products will be stored or used unless the main burner and pilot flames

Water heater has a main burner and pilot flame.

The pilot flame:

1. is on all the time and
2. will ignite flammable vapors.

Vapors:

1. cannot be seen,
2. are heavier than air,
3. go a long way on the floor,
4. can be carried from other room to the pilot flame by their currents.

are at least 18" above the floor. This will reduce, but not eliminate, the risk of vapors being ignited by the main burner or pilot flame.

Read and follow water heater warnings and instructions. If owners manual is missing, contact the retailer or manufacturer.

## ⚠ DANGER

**LIQUEFIED PETROLEUM MODELS – Propane, or LP gas, must be used with great caution.**

- It is heavier than air and will collect first in lower areas making it hard to detect at nose level.
- Make sure to look and smell for LP leaks before attempting to light appliance. Use a soapy solution to check all gas fittings and connections. Bubbling at a connection indicates a leak that must be corrected. When smelling to detect an LP leak, be sure to sniff near the floor too.
- Gas detectors are recommended in LP applications and their installation should be in accordance with the manufacturer's recommendations and/or local laws, rules, regulations or customs.
- It is recommended that more than one method be used to detect leaks in LP applications.

**IF LP GAS IS PRESENT OR SUSPECTED:**

- DO NOT attempt to find the cause yourself;
- DO NOT try to light any appliance;
- DO NOT touch any electrical switch;
- DO NOT use any phone in your building.
- Leave the building immediately and make sure that everyone else leaves also.
- Leave the doors open for ventilation and contact the gas supplier, a qualified service agency or the fire department.
- Keep the area clear until the service call has been made, the leak is corrected, and a qualified agency has determined the area to be safe.

## ⚠ WARNING

Both LP and natural gas have an odorant added to help detection. Some people may not physically be able to smell or recognize this odorant. If unsure or unfamiliar about the smell associated with LP or natural gas, ask the gas supplier. Other conditions, such as "Odorant Fade", which causes the odorant to "fade", or diminish in intensity can also hide or camouflage a gas leak.

## ⚠ DANGER

Water heaters utilizing Liquefied Petroleum gas (LP) are different from natural gas models. A natural gas heater will not function safely on LP gas and vice versa. Conversion from Natural gas to LP gas (or vice versa) must be done by a qualified service technician. To avoid possible equipment damage, personal injury or fire: DO NOT connect this water heater to a fuel type not in accordance with unit data plate. Propane for propane units. Natural gas for natural gas units. These units are not certified for any other type fuel.

## ⚠ WARNING

LP appliances should not be installed below-grade (for example, in a basement) if such installation is prohibited by federal, state and/or local laws, rules, regulations or customs.

## General Safety Precautions

To meet commercial hot water requirements, the tankstat is adjustable up to 190°F. However, water temperatures over 125°F. can cause severe burns instantly or death from scalds. This is the preferred starting point for setting the control for supplying general purpose hot water.

Safety and energy conservation are factors to be considered when setting the water temperature on the tankstat. The most energy efficient operation will result when the temperature setting is the lowest that satisfies the needs consistent with the application.

The following chart details the relationship of water temperature and time with regard to scald injury and may be used as a guide in determining the safest water temperature for your applications.

Temperature	Time to Produce Serious Burn
120°F.	More than 5 minutes
125°F.	1-1/2 to 2 minutes
130°F.	About 30 seconds
135°F.	About 10 Seconds
140°F.	Less than 5 seconds
145°F.	Less than 3 seconds
150°F.	About 1-1/2 seconds
155°F.	About 1 second

Table courtesy of Shiners Burn Institute

### TIME/TEMPERATURE RELATIONSHIPS IN SCALDS

The temperature of the water in the storage tank can be regulated by setting the temperature dial on front of the tankstat. To comply with safety regulations, the tankstat was set at its lowest setting before shipment from the factory. The illustration below illustrates the tankstat and how to adjust the water temperature.

To adjust the water temperature, insert a small straight screwdriver into slotted screw in hole in front of tankstat and turn wheel to desired setting. Tankstat is adjustable up to 190°F.

**CAUTION!! - Hotter water increases the risk of SCALDING!**



**DANGER**

**Water temperature over 125°F can cause severe burns instantly or death from scalds.**

**Children, disabled and elderly are at highest risk of being scalded.**

**See instruction manual before setting temperature at tankstat.**

**Feel water before bathing or showering.**

**Temperature limiting valves are available, see manual.**

Maximum water temperatures occur just after burner has shut off. To find hot water temperature being delivered, turn on a hot water faucet and place a thermometer in the hot water stream and read the thermometer.



There is a Hot Water SCALD Potential if the tankstat is set too high.

**NOTE:** When this water heater is supplying general purpose hot water requirements for use by individuals, a thermostatically controlled mixing valve for reducing point of use water temperature is recommended to reduce the risk of scald injury. Contact a licensed plumber or the local plumbing authority for further information.

### 3. INSTALLATION PROCEDURES

#### CODE REQUIREMENTS

Installation must be in accordance with **local codes**, or, in the absence of local codes, with the latest editions of the **National Fuel Gas Code, ANSI Z223.1, / NFPA 54**, and the **National Electrical Code, ANSI/ NFPA 70**. In Canada installations must conform with the current **CAN/CGA B149.1** or **.2** and the **Canadian Electrical Code Part 1 CSA C22.2 No.1**. Where required by the authority having jurisdiction, the installation must conform to American Society of Mechanical Engineers Safety Code for Controls and Safety Devices for Automatically Fired Heaters, **No. CSD-1**.

#### MOUNTING BASE

Heater should be mounted on a level surface. Each heater is designed with a built-in sub-base approved for mounting the heater on combustible flooring. Heater must **NOT** be installed on carpet flooring.

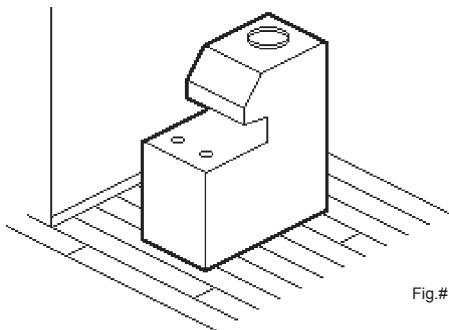
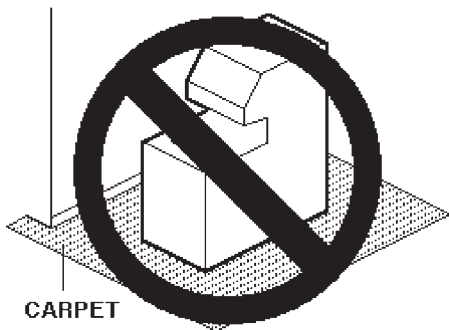

Fig.# 8193.1



CARPET

Fig.#8196.0

**NOTE:** The heater should be located in an area where water leakage will not result in damage to the area adjacent to the appliance or to the structure. When such locations cannot be avoided, it is recommended that a suitable drain pan, adequately drained, be installed under the appliance. The pan must not restrict air flow.

In addition, the heater shall be installed such that the gas ignition system components are protected from water (dripping, spraying, rain, etc.) during appliance

operation and service (circulator replacement, control replacement, etc.)

#### CLEARANCE REQUIREMENTS

1) Minimum Clearances From Combustible Materials

Model No.	Floor	Front	Back	Right	Left	Top	Flue Vent
0090							
0135	Comb.	Alcove	6"	6"	6"	16"	6"
0195							

- 2) A front clearance of at least 24" is recommended for adequate service of burner-tray and controls.
- 3) Except for carpeted flooring, heaters are certified for installation on combustible floors.
- 4) For un-insulated hot water pipes, maintain a 2" clearance, or consult local authority having jurisdiction.

#### COMBUSTION/VENTILATION AIR

**WARNING:** Air supply to the heater room must not be affected by mechanical exhaust vents located in other parts of the house, such as kitchen or bathroom fans, or attic blowers. Mechanical exhaust vents may create a negative pressure condition in the heater room that can become a hazard of asphyxiation, explosion or fire.

**CAUTION:** Combustion air must not be contaminated by corrosive chemical fumes which can damage the heater. Measures must be taken to prevent the entry of corrosive chemical fumes to the combustion and ventilation air supply. Such chemicals include, but are not limited to, chlorinated and/or fluorinated hydrocarbons such as found in refrigerants, aerosol propellants, dry-cleaning fluids, degreasers, and paint removers. Other harmful elements may come from bleaches, air fresheners, or mastics. Vapors from these types of products can form corrosive acid compounds when burned in a gas flame. The resulting acid condensate can damage or substantially reduce the life of the heater. It may be necessary to provide outside air directly to the heater in order to avoid this problem.

- 1) The heater must be provided with adequate supply of air for proper combustion and ventilation in accordance with **Sec. 5.3**, of the latest edition of the **National Fuel Gas Code, ANSI Z223.1**, or applicable provisions of the local building codes.



- 2) If the heater room is located against an outside wall and air openings can communicate directly with the outdoors, the two openings on the outside wall must each have a net free area, in square inches as follows:

<u>Model</u>	<u>Sq. In. Of Free Area</u>
0090	24
0135	35
0195	50

Location of the openings is the same as in the previous case - that is, within 12 inches of the top, and within 12 inches of the bottom of the enclosure. If horizontal ducts are used, the area must be doubled and the duct area shall not be less than the area of the openings they connect, and in no case shall the smallest dimension be less than 3 inches.

### **VENTING CONNECTIONS**

These heaters have built-in drafthoods. Vent piping the same size or larger than the draft hood outlet is recommended; however, when the total vent height (drafthood outlet to vent terminal) is at least ten (10) feet, the vent pipe size may be reduced by one size only as specified in Chapter 10 of the latest edition of the National Fuel Gas Code, **ANSI Z 223.1**. As much as possible avoid long horizontal runs of vent pipe and too many elbows. If installation requires horizontal runs, the vent pipe must have a minimum of 1/4 inch per foot rise and should be supported at not less than five foot intervals. Maximum vent connector horizontal length shall be 1-1/2 feet (18 inches) for each inch of connector diameter as follows.

Heater Size	Vent Connector Diameter	Max Horizontal Length - FT
90	5"	7.5
135	6"	9
195	7"	10.5

Gas Vents supported only by the flashing and extending above the roof more than five feet should be securely guyed or braced to withstand snow and wind loads. We recommend use of insulated vent pipe spacer through the roofs and walls.

For protections against rain or blockage by snow, the vent pipe must terminate with a listed vent cap which complies with the local codes or, in the absence of such codes, to the latest edition of the National Fuel Gas Code, **ANSI Z 223.1**.

The discharge opening must be a minimum of two feet vertically from the roof surface and at least two (2) feet higher than any part of the building within ten (10) feet. Vent stack shall be at least five (5) feet in vertical height above the drafthood outlet. The vent cap location shall have a minimum clearance of four (4) feet horizontally from, and in no case above or below, unless a 4-foot horizontal distance is maintained, from electric meters, gas meters regulators and relief equipment.

The weight of the vent stack or chimney must not rest on heater draft hood. Support must be provided in compliance with applicable codes. The heater top and draft hood must be readily removable for maintenance and inspection. Vent pipe should be adequately supported to maintain proper clearances from combustible construction.

Type "B" double wall (or equivalent vent pipe is recommended. However single wall metal vent pipe may be used as specified in the latest edition of the National Fuel Gas Code **ANSI Z 223.1**.

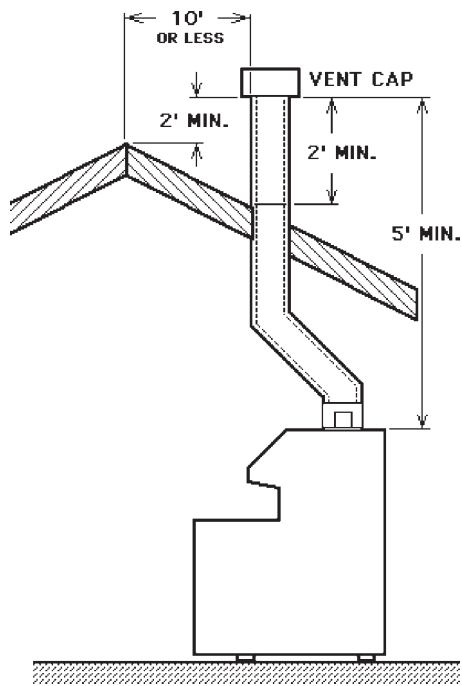

Fig.# 8191.1

**WARNING:** *These heaters must not be connected into any portion of mechanical draft systems operating under positive pressure. To do so may cause the flue products to be discharged into the living space causing serious health injury.*

For connections to gas vents or chimneys, vent installations shall be in accordance with Part 7, Venting of Equipment, of the National Fuel Gas Code, **ANSI Z223.1**, or applicable provisions of the local building codes.

### COMMON VENTS

Manifolds that connect more than one heater to a common chimney must be sized to handle the combined load. Consult available guides for proper sizing of the manifold and the chimney. **At no time should the area be less than the area of the largest outlet.**

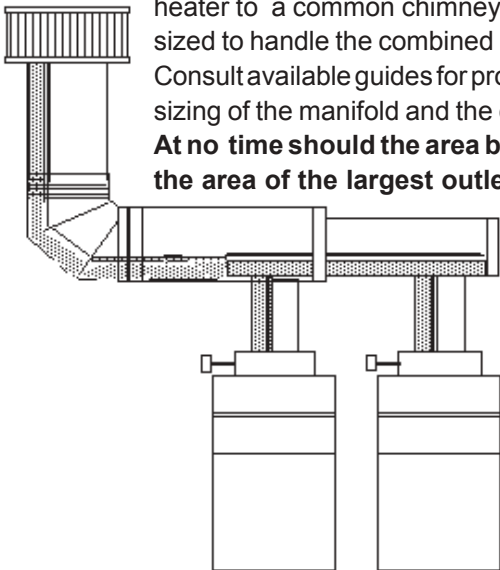

Fig. #9001



At the time of removal of an existing heater, the following steps shall be followed with each appliance remaining connected to the common venting system placed in operation, while the other appliances remaining connected to the common venting system are not in operation.

- (a) Seal any unused openings in the common venting system.
- (b) Visually inspect the venting system for proper size and horizontal pitch and determine there is no blockage or restriction, leakage, corrosion and other deficiencies which could cause an unsafe condition.
- (c) Insofar as is practical, close all building doors and windows and all doors between the space in which the appliances remaining connected to the common venting system are located and other spaces of the building. Turn on clothes dryers and any appliance not connected to the common venting system. Turn on any exhaust fans, such as range hoods and bathroom exhausts, so they will operate at maximum speed. Do not operate a summer exhaust fan. Close fireplace dampers.
- (d) Place in operation the appliance being inspected. Follow the lighting instructions. Adjust tankstat so appliance will operate continuously.
- (e) Test for spillage at the draft hood relief opening after 5 minutes of main burner operation. Use the flame of a match or candle, or smoke from a cigarette, cigar or pipe to visually check spillage.
- (f) After it has been determined that each appliance remaining connected to the common venting system properly vents when tested as outlined above, return doors, windows, exhaust fans, fireplace dampers and any other gas burning appliance to their previous conditions of use.
- (g) Any improper operation of the common venting system should be corrected so the installation conforms with the latest edition of the National Fuel Gas Code, ANSI Z 223.1. When resizing any portion of the common venting system, the common venting system should be resized to approach the minimum size as determined using the appropriate tables in Chapter 10 and in Appendix G of the National Fuel Gas Code, ANSI Z 223.1 and CAN/CGA - B149.1 -B149.2.

## GAS SUPPLY CONNECTIONS

The inlet gas connection of the heater gas valve is 1/2". Provide an adequate gas piping supply line no smaller than 1/2", according to the chart below:

Maximum Equivalent Pipe Length (Feet)

MODEL	1/2" Pipe		3/4" Pipe		1" Pipe		1-1/4" Pipe	
	NAT	PROP	NAT	PROP	NAT	PROP	NAT	PROP
0090	30	80	125	300	400	-	-	-
0135	15	40	60	150	200	500	-	-
0195	-	20	35	70	100	250	400	-

Gas piping must have a sediment trap ahead of the heater gas controls, and a manual shutoff valve located outside the jacket. All gas piping should be tested after installation in accordance with local codes.

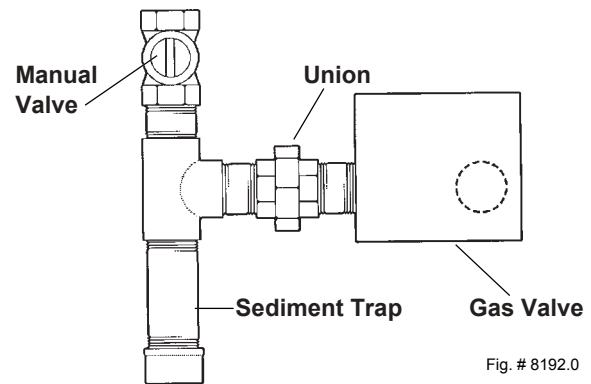

Fig. # 8192.0

**CAUTION:** The heater and its manual shut off valve must be disconnected from the gas supply during any pressure testing of that system at test pressures in excess of 1/2 psig (3.45 KPA). Dissipate test pressure in the gas supply line before reconnecting the heater and its manual shut off valve to gas supply line. FAILURE TO FOLLOW THIS PROCEDURE MAY DAMAGE THE GAS VALVE. OVER PRESSURED GAS VALVES ARE NOT COVERED BY WARRANTY. The heater and its gas connections shall be leak tested before placing the appliance in operation. Use soapy water for leak test. DO NOT use open flame.

**NOTE:** Do not use teflon tape on gas line pipe thread. A flexible sealant suitable for use with Natural and Propane gases is recommended.

**NOTE:** These boilers are also certified to operate on Propane gas, when equipped with the combination gas valve and orifices (pilot and main burners) sized for Propane gas.

### GAS PRESSURE-SPECIFICATIONS

	Inches	W.C.	Regulator Setting
	Min.	Max.	
Natural	4.5	10.5	3.5
Propane	12.0	13.0	11.0

Note: Do not exceed maximum inlet gas pressure. The minimum value shown is for input adjustment.

The gas valve is provided with pressure taps to measure gas pressure upstream of the gas valve and downstream which is the same as the manifold pressure.

### **WATER CONNECTIONS & SYSTEM PIPING**

The pipe size and fittings between the heater and the tank should be at least 1" for model 90, and 1-1/4" for models 135 and 195. This is based on the tank being located as close to the heater as possible, as shown in the drawing below:

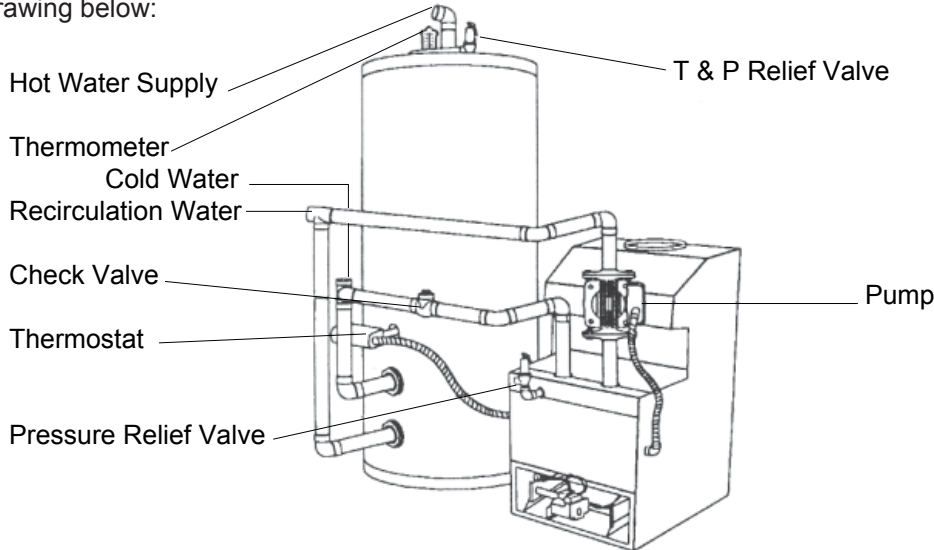

If this water heater is installed in a closed water supply system, such as one having a back-flow preventer in the cold water supply line, means shall be provided to control thermal expansion. Contact the water supplier or local plumbing inspector on how to control this situation.

When this water heater system is supplying general purpose hot water requirements for use by individuals, a thermostatically controlled mixing valve is recommended to reduce the risk of scald injury. Contact a licensed plumber or the local plumbing authority for further information.

Thermometer(s) should be installed so that they indicate the water temperature at or near the outlet of the storage tank.

### **RELIEF VALVE**

A new combination temperature and pressure (T & P) relief valve, complying with the Standard for Relief Valves and Automatic Gas Shut Off Devices for Hot Water Supply Systems, ANSI Z21.22, must be installed in the opening provided on top of the storage tank, at the time of installation. No valve is to be placed between the relief valve and the storage tank.

The pressure rating of the relief valve must not exceed the 160 maximum working pressure indicated on the water heater rating plate. The BTUH rating of the relief valve must not be less than the BTUH input of the heater.

Connect the outlet of the relief valve to a suitable open drain. The discharge line must pitch downward from the valve to allow complete draining (by gravity) of the relief valve and discharge line. The discharge line should be no smaller than the outlet of the valve. The end of the discharge line should not be threaded or concealed, and should be protected from freezing. No valve of any type, restriction or reducer coupling, should be installed in the discharge line. Local codes shall govern installation of relief valve.

## ELECTRICAL WIRING

The electrical power supply requirement for these heaters is 115 volts, 60 Hz. Field wiring connections and electrical grounding must comply with the local codes, or in the absence of local codes, with the latest edition of the National Electrical Code, **ANSI/NFPA 70**. Provide a separate fused circuit from the main electrical panel to the heater, and a disconnecting means within sight of the heater.

Remove the control box cover and make the power supply connections in the field wiring compartment. (See general location of controls drawing on page 13). The pump is supplied and factory wired to operate with the heater.

The thermostat (tankstat) is shipped loose to be installed in the tank at the installation site.

**WARNING: SHOCK HAZARD** LINE VOLTAGE IS PRESENT. BEFORE SERVICING TANKSTAT OR HEATER, TURN OFF ELECTRICAL POWER TO THE HEATER AT THE MAIN DISCONNECT OR CIRCUIT BREAKER. FAILURE TO DO SO COULD RESULT IN SEVERE PERSONAL INJURY OR DEATH.

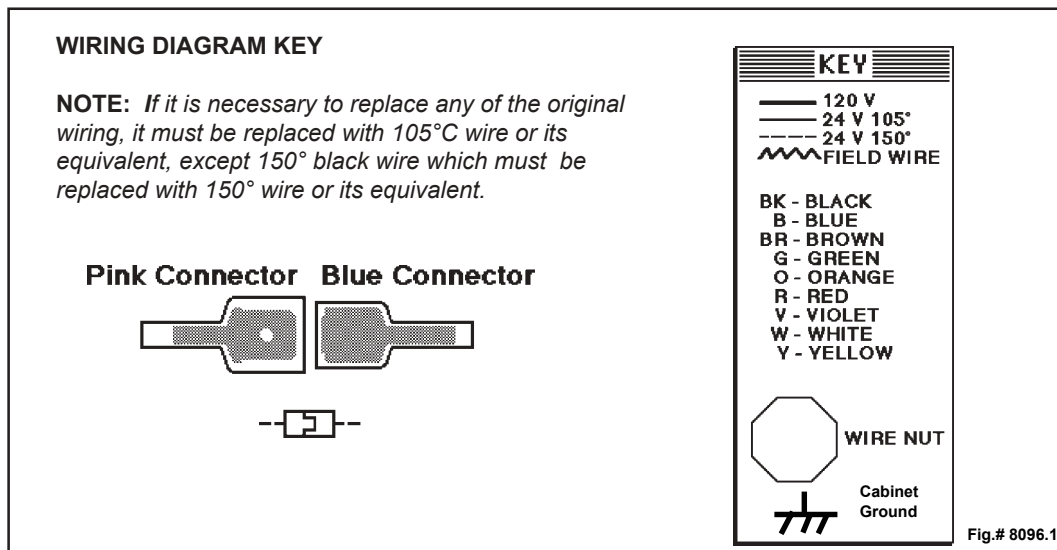

**WIRING DIAGRAM: STANDING PILOT  
MODELS 90, 135 and 195**

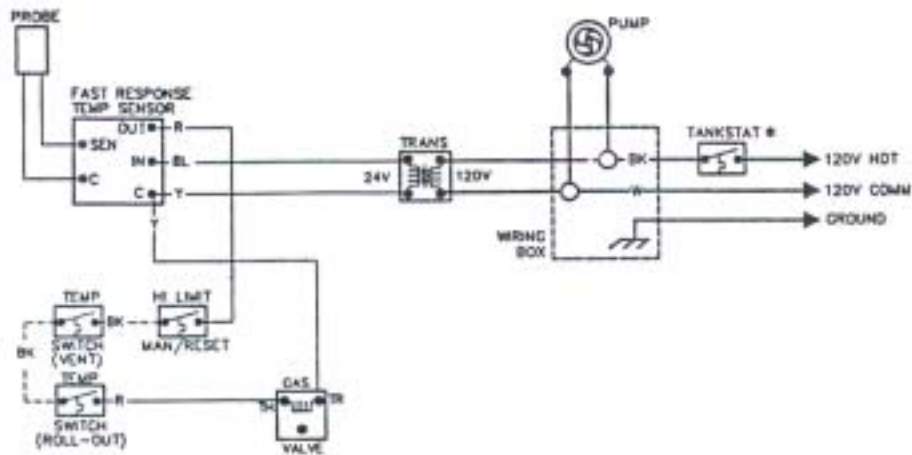

**WARNING: SHOCK HAZARD** LINE VOLTAGE IS PRESENT. BEFORE SERVICING TANKSTAT OR HEATER, TURN OFF ELECTRICAL POWER TO THE HEATER AT THE MAIN DISCONNECT OR CIRCUIT BREAKER. FAILURE TO DO SO COULD RESULT IN SEVERE PERSONAL INJURY OR DEATH.

**WIRING DIAGRAM: INTERMITTENT IGNITION DEVICE (IID)  
MODELS 90, 135 and 195**

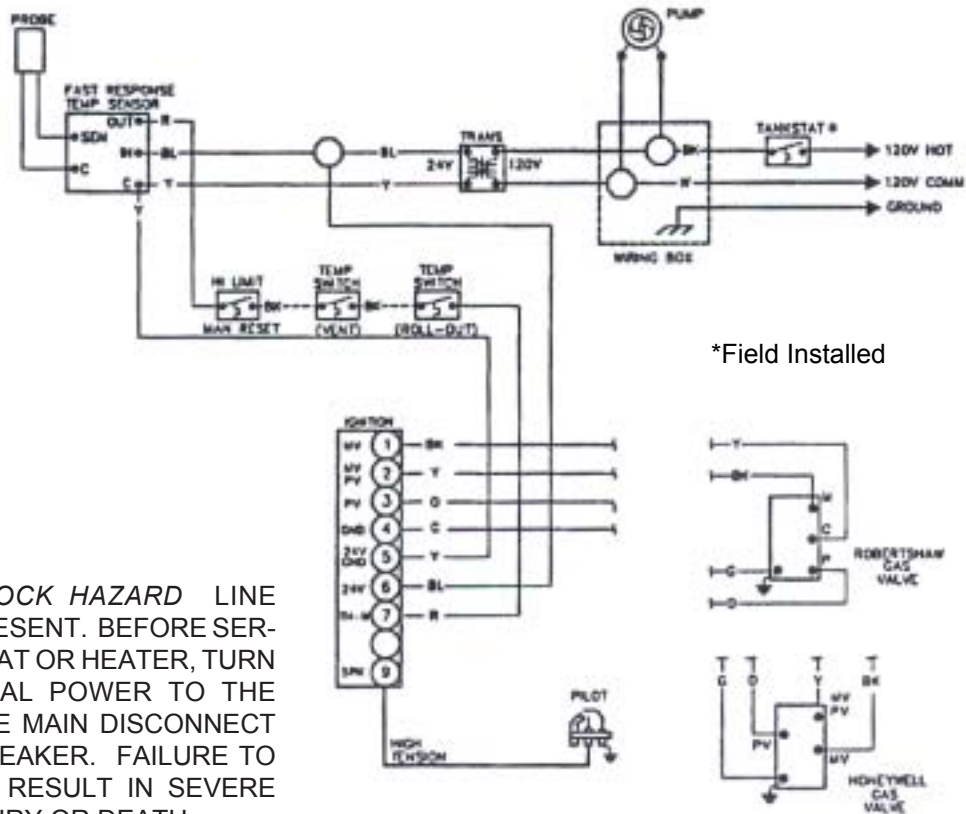

\*Field Installed

**WARNING: SHOCK HAZARD** LINE VOLTAGE IS PRESENT. BEFORE SERVICING TANKSTAT OR HEATER, TURN OFF ELECTRICAL POWER TO THE HEATER AT THE MAIN DISCONNECT OR CIRCUIT BREAKER. FAILURE TO DO SO COULD RESULT IN SEVERE PERSONAL INJURY OR DEATH.

See page 11 wiring diagram key information.

## 4. SERVICING PROCEDURES

### GENERAL LOCATION OF CONTROLS

#### CONTROL BOX COMPONENT LOCATIONS

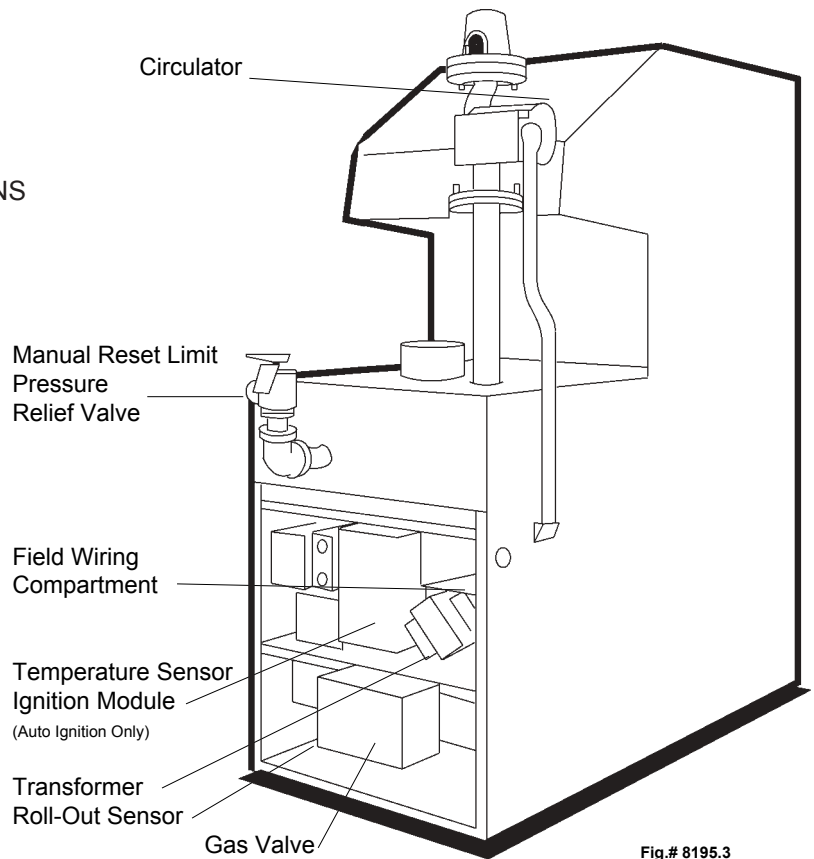
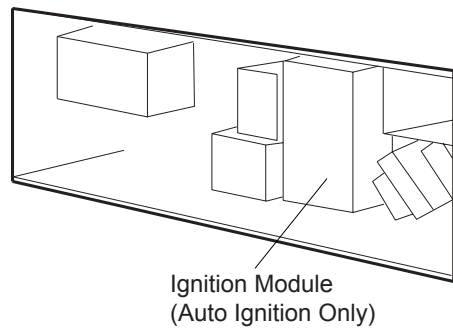

Fig.# 8195.3

### SEQUENCE OF OPERATION

#### INTERMITTENT IGNITION DEVICE (IID)

Heaters equipped with the IID system will automatically light the pilot burner first and then the main burner, each time there is a call for heat from the tankstat. Whenever the tankstat is calling for heat, the circulator supplied with the heater, will be energized and should be running. The ignition control module will also be energized to initiate the pilot ignition by opening the first main valve (pilot). At the same time, the electronic spark generator in the module produces a high voltage spark pulse output that lights the pilot burner. If the pilot burner does not light, the module will not energize the second main valve and the burners will not light. Ignition spark continues only until the timed trial for ignition period ends. Then, the module goes into safety shutdown or lockout. Lockout de-energizes the first main valve operator and closes the first main (pilot) valve in the gas control, stopping pilot gas flow. The ignition control system must be reset by setting the tankstat below water temperature for one minute or by turning off power to the module for one minute. When the pilot flame is established, flame rectification circuit is completed between the sensor and burner ground. The flame sensing circuit in the module detects the flame current, shuts off the spark generator and energizes the second main valve operator which opens the second main valve. This allows gas to flow to the burners where it is ignited by the pilot burner flame. When the tankstat is satisfied, the valve operators are de-energized shutting off the pilot and main burners, and also the circulator.

## START-UP PROCEDURES

### SECTION 1. Filling the System

Fill system with water. Purge all air from the system using purge valve sequence. After system is purged of air, lower system pressure.

Flush system before putting into operation to assure that foreign material does not damage pump seals.

### SECTION 2. Checking the Circulator

Before lighting the heater and after system is filled, make sure that circulator is operating properly. Manual gas valve should be off.

**NOTE:** *Circulator motor supplied with the heater does not require lubrication.*

### FOR STANDING PILOT MODEL WITH ROBERTSHAW GAS VALVE, ON/OFF OPERATION

1. **STOP!** Read the safety information above.
2. Set the tankstat on the lowest setting.
3. Turn OFF all electric power to the heater.
4. Push in gas control knob slightly and turn clockwise to "OFF".

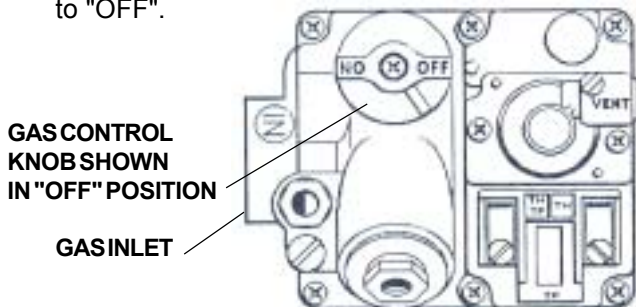

**NOTE:** *Knob cannot be turned from "PILOT" to "OFF" unless knob is pushed in slightly. Do not force.*

5. Wait five (5) minutes to clear out any gas. Then smell for gas, including near the floor. If you smell gas, STOP! Follow "B" in the safety information above on this label. If you don't smell gas, go to the next step.
6. Locate pilot behind gas valve mounted on the base panel of the burner drawer.
7. Turn knob on gas control counter-clockwise to "Pilot".

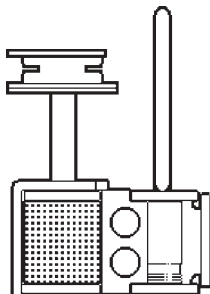

Fig.# 8083.2

HONEYWELL PILOT

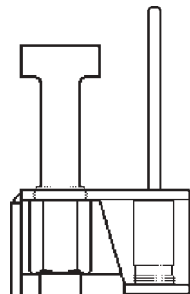

Fig.# 8041.2

ROBERTSHAW PILOT

8. Push in control knob all the way and hold in, immediately light the pilot with a match. Continue to hold control knob in for about one minute after the pilot is lighted, release knob and it will pop back up. Pilot should remain lighted. If it goes out, repeat steps 4 through 8.

\* If knob does not pop up when released, stop and immediately call your service technician or gas supplier.

\* If the pilot does not stay lit after several tries, turn the gas control knob to "OFF" and call your service technician or gas supplier.

9. Stand to the side of the heater and turn the gas control knob counter-clockwise to "ON".
10. Turn "ON" all electrical power to the heater.
11. Set the tankstat to the desired setting.

### FOR STANDING PILOT MODEL WITH HONEYWELL GAS VALVE, ON/OFF OPERATION

1. **STOP!** Read the safety information.
2. Set the tankstat to the lowest setting.
3. Turn Off all electrical power to the heater.
4. Turn gas control knob clockwise to "OFF".

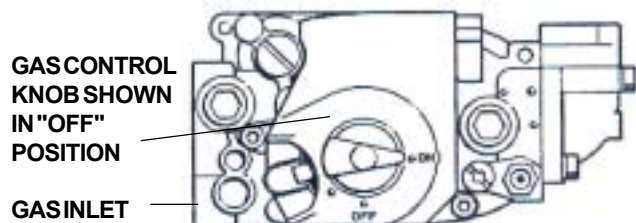

5. Wait five (5) minutes to clear out any gas. Then smell for gas, including near the floor. If you smell gas, STOP! Follow "B" in the safety information above on this label. If you don't smell gas, go to the next step.
6. Locate pilot behind gas valve, mounted on the base panel of the burner drawer.
7. Turn knob on gas control counter-clockwise to "PILOT".

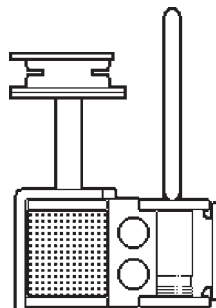

Fig.# 8083.2

HONEYWELL PILOT

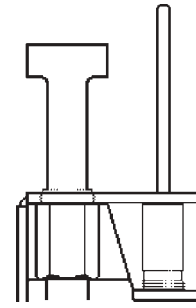

Fig.# 8041.2

ROBERTSHAW PILOT



8. Push down and hold the red reset button in, immediately light the pilot with a match. Continue to hold down red reset button for about one minute after the pilot is lighted. Release red reset button and it will pop back up. Pilot should Remain lighted. If it goes out, repeat steps 4 through 8.
  - \* If red reset button does not pop up when released stop and immediately call your service technician or gas supplier.
  - \* If the pilot does not stay lit after several tries, turn the gas control knob to "OFF" and call your Service technician or gas supplier.
9. Stand to the side of the heater and turn the gas control knob counter-clockwise to "ON".
10. Turn "ON" all electrical power to the heater.
11. Set the tankstat to the desired setting.

#### SYSTEM SHUT DOWN PROCEDURE

1. Set the tankstat to "OFF" or the lowest setting.
2. Turn off all electric switches to the heater.
3. Turn off all gas valves supplying gas to the heater. Refer to operating instruction label on the heater.
4. Shut off the water supply to the heater piping system loop.
5. Open drain valve on the tank to remove water from the heater and the piping circuits.

#### **SECTION 3. Lighting the Heater**

**CAUTION:** *Liquefied petroleum gas is heavier than air and sinks to the ground. Exercise extreme care in lighting heater in confined areas.*

##### **For Standing Pilot Models**

**WARNING:** *If you do not follow these instructions exactly, a fire or explosion may result causing property damage, personal injury or loss of life.*

A. This heater has a pilot which must be lighted by hand. When lighting the pilot, follow these instructions exactly.

B. **BEFORE LIGHTING** Smell all around the heater area for gas. Be sure to smell next to the floor because some gas is heavier than air and will settle on the floor.

##### WHAT TO DO IF YOU SMELL GAS

- Do not try to light any appliance.
- Do not touch any electric switch;
- Do not use any phone in your building.
- Immediately call your gas supplier from a neighbor's phone. Follow the gas supplier's instructions.
- If you cannot reach your gas supplier, call the fire department.

C. Use only your hand to push in, move or turn the gas control knob or lever. Never use tools. If the knob or lever will not push in, move or turn by hand, don't try to repair it, call a qualified service technician. Force or attempted repair may result in a fire or explosion.

D. Do not use this heater if any part has been under water. Immediately call a qualified service technician to inspect the heater and to replace any part of the control system and any gas control which has been under water.

#### **FOR AUTOMATIC IGNITION MODELS.**

Please read carefully and understand the following safety information before operating the heater.

**WARNING:** *If you do not follow these instructions exactly, a fire or explosion may result causing property damage, personal injury or loss of life.*

A. This heater is equipped with an ignition device which automatically lights the pilot. Do not try to light the pilot by hand.

B. **BEFORE OPERATING** smell all around the heater area for gas. Be sure to smell next to the floor because some gases are heavier than air and will settle on the floor.

##### WHAT TO DO IF YOU SMELL GAS

- Do not try to light any appliance.
- Do not touch any electric switch;
- Do not use any phone in your building.
- Immediately call your gas supplier from a neighbor's phone. Follow the gas supplier's instructions.
- If you cannot reach your gas supplier, call the fire department.

C. Use only your hand to push in, move or turn the gas control knob or lever. Never use tools. If the knob or lever will not push in, move or turn by hand don't try to repair it, call a qualified service technician. Force or attempted repair may result in a fire or explosion.

D. Do not use this heater if any part has been underwater. Immediately call a qualified service technician to inspect the heater and to replace any part of the control system and any gas control which has been underwater.

**FOR INTERMITTENT IGNITION (IID) WITH HONEYWELL OR ROBERTSHAW GAS VALVE**

1. **STOP!** Read the safety information above.
2. Set the tankstat to the lowest setting.
3. Turn off all electric power to the appliance.
4. This heater is equipped with an ignition device which automatically lights the pilot. Do not try to light the pilot by hand.

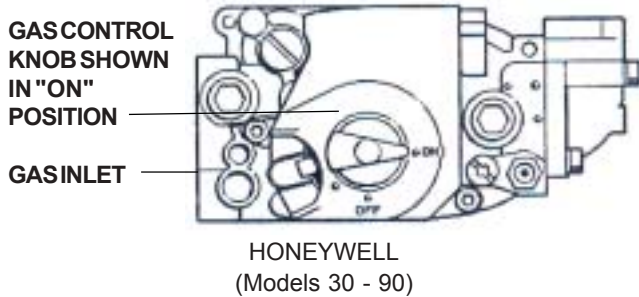

5. **For Honeywell Valve:** Turn gas control knob clockwise to "Off".  
**For Robertshaw Valve:** Push in and move gas control lever to "Off" position.
6. Wait 5 minutes to clear out any gas. If you then smell gas **STOP!** Follow "B" in the safety information previously stated. If you don't smell gas, go to the next step.
7. **For Honeywell Valve:** turn gas control counter-clockwise to "On".  
**For Robertshaw Valve:** Move gas control lever to "On" position.

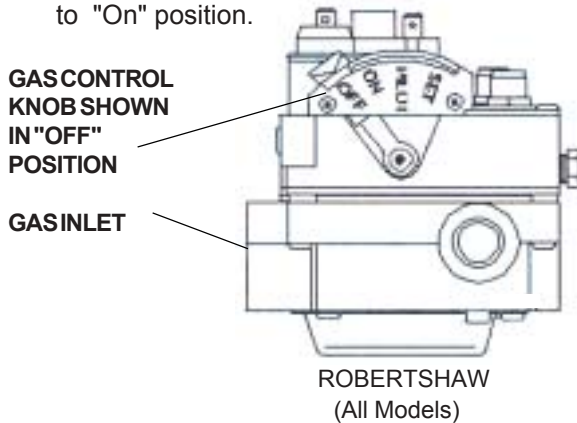

8. Turn on all electric power to the heater.
9. Set tankstat to desired setting.
10. If the heater will not operate, follow the instruction "To Turn Off Gas To Heater" and call your service technician or gas supplier.

**TO TURN OFF GAS TO HEATER**

1. Set the tankstat at the lowest setting.
2. Turn off all the electric power to the heater if service is to be performed.
3. **For Honeywell Valve:**  
Turn gas control knob clockwise to "Off". Make sure knob rest against stop.  
**For Robertshaw Valve:**  
Push in and move gas control lever to "Off" position.

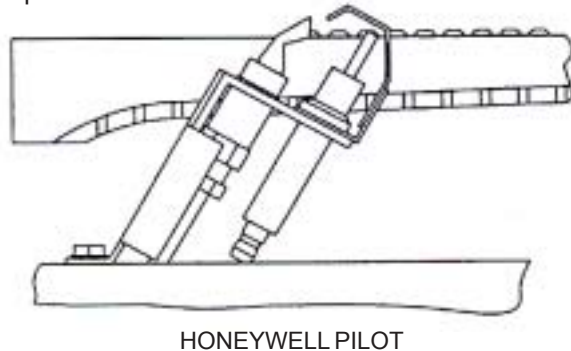

**CAUTION:** Should overheating occur or the gas supply fails to shut off, **DO NOT** turn off or disconnect the electrical supply to the pump. Instead, shut off the gas supply at a location external to the heater. Failure to observe this precaution may aggravate the overheated condition resulting in possible damage to the heater and injury to the user.

**SECTION 4. Testing the Ignition Safety Shutoff.**

The ignition system safety shutoff must be tested by conducting the following method of tests:

For Standing Pilot Systems

- a. With the main burners on, remove the pilot adjustment cover screw.
- \* **NOTE:** *There is no pilot adjustment cover on Robertshaw 7200 gas valve.*
- b. Insert a small slot screw driver and turn the adjustment screw clockwise until pilot flame goes out. Note and count number of turns made.
- c. Gas valve will shut off main burners after about three (3) minutes. End of test. If the gas valve will not shut off, follow the instructions "To Turn Off Gas To Heater" and call service technician or your gas supplier.
- d. Return pilot adjustment screw counter-clockwise, same number of turns as in step (b)

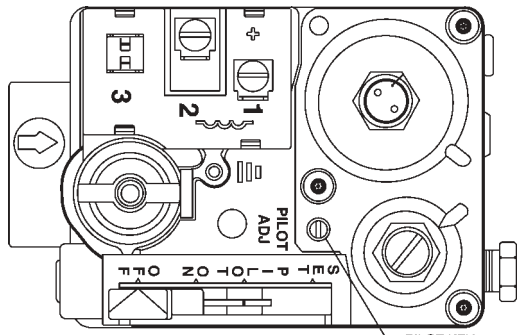

Fig.# 8935.0

Pilot Adjustment

**ROBERTSHAW 7200 GAS VALVE  
(Models 135 & 180)**

- e. Replace pilot adjustment cover screw, then follow the lighting instructions to get heater ready for operation.

**FOR AUTOMATIC IGNITION SYSTEMS**

**A. Intermittent Ignition (IID)**

1. Turn on power to the ignition systems and turn gas supply off at the gas valve.
2. Check ignition module as follows:
  - a. Set the tankstat to high setting.
  - b. Watch for continuous spark at the pilot burner.
  - c. Time the spark operation. Time must be within the lockout timing period (15 or 90 seconds).
  - d. Turn tankstat down to end call for heat and wait 60 seconds on lockout models before beginning step 3.
3. Turn on gas supply.
4. Set tankstat to high setting.
5. Systems should start as follows:
  - a. Spark will turn on and pilot gas valve will open at once. Pilot burner should ignite after gas reaches the pilot burner.
  - b. Spark ignition should cut off when pilot flame is established.
  - c. Main gas valve should open and main burner should ignite after gas reaches the burner port

**FLAME FAILURE**

With burner operating, close the manual fuel valves to simulate a flame failure. System should lock out after safety switch timing (15 seconds). After the safety switch has cooled, open the manual valves (relight standing pilots) and reset the safety switch; the burner should restart.

**INSPECTION PROCEDURES**

**BURNERS**

Clean main burners and air louvers of dust, lint and debris. Keep heater area clear and free from combustibles and flammable liquids. Do not obstruct the flow of combustion and ventilating air. Make visual check of burner and pilot flame. Yellow flame indicates clogging of air openings. Lifting or blowing flame indicates high gas pressure. Low flame indicates low gas pressure.

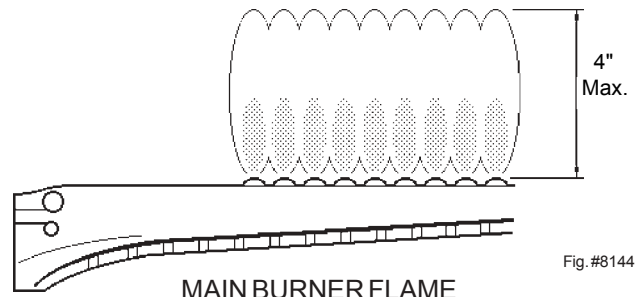

Fig. #8144

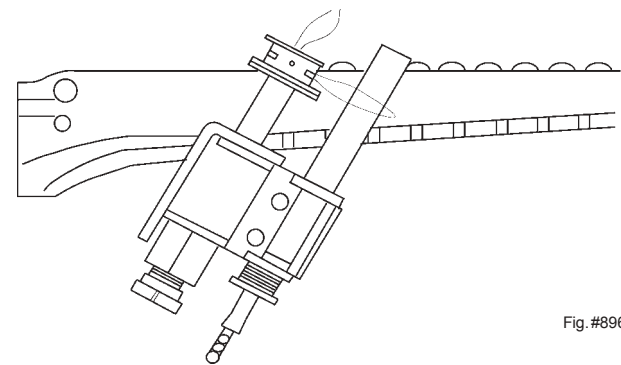

Fig. #8964

**NORMAL INSPECTION PROCEDURES**

First and third month after initial start up and then on an annual basis. If problems are found, refer to Trouble Shooting Guide for additional directions.

1. Remove top of heater and inspect heat exchanger for soot and examine venting system.
  2. Remove rear header and inspect for scale deposits.
  - \*3. Inspect pilot and main burner flame and firing rate.
  - \*4. Inspect and operate all controls and gas valve.
  - \*5. Visually inspect system for water leaks.
  - \*6. Oil pump motor and bearing assembly, if oil cups are provided.
  7. Check flow switch paddle. (If provided)
  8. Clean room air intake openings to assure adequate flow of combustion and ventilation air.
  9. Keep heater area clear and free from combustible materials, gasoline, and other flammable vapors and liquids.
- \*Should be checked monthly. (Takes approximately 15 minutes).

## PROCEDURE FOR CLEANING FLUE GAS PASSAGE-WAYS

Soot will clog areas behind fins and cause eventual tube failure. Any sign of soot at base of burners or around outer jacket indicates a need for cleaning.

1. Lift off draft hood and flue collector by removing bolts and screws.
2. Remove "V" baffles from heat exchanger.
3. Remove burner tray, see Burner Drawer Removal.
4. Take garden hose and wash heat exchanger, making sure soot is removed from between fins. (Avoid excessive water against refractory).
5. Reassemble; when heater is fired, some steam will form from wet refractory. This is normal.

**NOTE:** In extreme cases it may be necessary to remove the heat exchanger completely for cleaning. The simplest method is steam cleaning at a local car wash. DO NOT WIRE BRUSH!

### CAUTION:

Soot is combustible, so exercise extreme care.

## BURNER DRAWER REMOVAL

1. Shut off power and gas supply to the heater. Disconnect union(s) and pilot tubing when present; then loosen and remove burner hold down screws.
2. Disconnect wires at gas valve and slide burner drawer out.

## MAIN BURNER AND ORIFICE REMOVAL

1. Remove screws and burner hold down bracket.

**NOTE:** If the heat exchanger is sooted badly, the burner hold down bracket and spacer can become distorted from direct flame impingement and this usually necessitates replacement of these parts.

2. Lift burners from slotted spacer and slide from orifices. Clean with a wire brush.
3. Orifices usually do not need to be replaced. To clean, run either copper wire or wood through orifice. Do not enlarge hole. To remove orifice, use a socket wrench and remove the manifold. DO NOT overtighten when reinstalling.

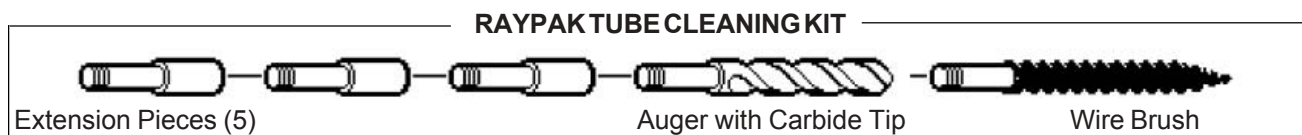

Fig. #8185

## REPAIR SECTION

### TUBE CLEANING PROCEDURE (TYPICAL)

Establish a regular inspection schedule, the frequency depending on the local water condition and severity of service. Do not let the tubes clog up solidly. Clean out deposits over 1/16" in thickness.

The heater may be cleaned from the side opposite the water connections as shown, without breaking pipe connections. It is preferable, however, to remove both headers for better visibility through the tubes and to be sure the residue does not get into the system.

Note that you do not remove the top pan or the heat exchanger generally.

After reaming with the auger, mount the wire brush and clean out the debris remaining in the tubes.

Another method is to remove the heat exchanger, ream tubes and immerse heat exchanger in non-inhibited de-scale solvent.

## HEAT EXCHANGER REMOVAL

1. Shut water, gas and electricity off, close valves and relieve pressure, remove relief valve. Remove side inspection panels.
2. Remove top holding screws.

3. Remove draft diverter, lift and remove top and flue collector on stack type models. Remove inspection panels.
4. Loosen bolts and disconnect flange nuts on inlet-outlet header, loosen union(s) at gas pipe, and slide heater away from piping until studs clear the heater.
5. Remove heat exchanger corner brackets.
6. Remove combustion chamber clips at the four corners of the heat exchanger.
7. Lift heat exchanger straight up using caution not to damage refractory.

## HEAT EXCHANGER RE-ASSEMBLY

1. Heat exchanger water header O-rings should be replaced with new ones.
2. Install inlet-outlet and return water headers and install header retainer nuts and torque nuts evenly.
3. Replace "V" baffles.
4. Install thermostat sensing bulbs in header wells and replace bulb retaining clips.
5. Install inlet and return pipes in water headers using pipe thread sealant.
6. Install water pressure relief valve, sensor probe, and low water cutoff devices if so equipped.
7. Open water supply and return shut-off valves. Fill heater and water piping system with water. Check heater and piping system for leaks at full line pressure. Run system circulating pump for a minimum of 1/2 hour with heater shut-off.
8. Shut down entire system and vent all radiation units and high points in system piping. Check all strainers for debris. Expansion tank water level should be at the 1/4 mark and the balance of the tank filled with air (when using Air-X-Tank).
9. Install flue collector, jacket top and inspection panels. Install top holding screws. Install draft diverter and vent piping if so equipped.
10. If gas piping was disconnected, reconnect gas piping system and check for leakage using a soap solution.
11. Check for correct water pressure and water level in the system. Make sure that system pump operates immediately on the call for heat. The system is ready for operation.
13. Within two (2) days of start-up, recheck all air vents and expansion tank levels.

## COMBUSTION CHAMBER REMOVAL

To remove combustion chamber you must first have removed the heat exchanger. Unbolt metal combustion chamber retainer from top and remove combustion chamber panels individually.

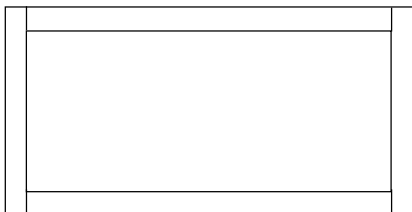



## 5. TROUBLE SHOOTING GUIDE

### IMPORTANT NOTICE

These instructions are primarily intended for the use of qualified personnel specifically trained and experienced in the installation of this type of heating equipment and related system components. Installation and service personnel may be required by some states to be licensed. Persons not qualified shall not attempt to install this equipment nor attempt repairs according to these instructions.

PROBLEM(S)	CAUSE(S)	SOLUTION(S)
1)When tankstat is turned on, heater does not operate.	1)No power to the heater.  2)Defective tankstat or disconnected wire in thermostat circuit.  3)Defective transformer.	1)Check circuit breakers, disconnect switch. Make sure power is on.  2)Check continuity on thermostat and wiring circuit. Replace thermostat, or repair wiring connections.  3) Check secondary voltage. If no 24V, replace transformer.
2)When tankstat is calling for heat, pump is on, but burners will not turn on.	1)For Standing pilot models pilot burner not lighted. 2)If pilot burner will not stay lighted, thermocouple or gas valve may be defective.  3)Gas knob in "Pilot" position. 4)Vent switch is open.  5)Roll-out switch is open.  6)Manual Reset High limit is open.  7) Fast Response Temperature Sensor probe is defective.  8) Fast Response Temperature sensor board is defective.  9) Defective ignition module or defective gas valve.	1)Light pilot burner. (Follow lighting instructions on rating plate). 2)Check thermocouple MV generation. If less than 25MV (open circuit), replace thermocouple. If between 25-35 MV, replace gas valve. 3)Turn knob to "ON" position. 4) Check for blockage of venting system or disconnected vent piping. After problem is corrected push button to reset vent switch. 5)Check for blockage of flue or sooted heat exchanger. After problem is corrected push button to reset roll-out switch. 6)Check water flow and adjust to obtain 8° to 10°F temperature rise. 7)Red LED on circuit board will be <u>ON</u> to indicate a loose sensor connection or a shorted sensor. Check terminal connectors or replace sensor as required. <b>NOTE:</b> Red LED will also be <u>ON</u> if sensor temperature exceeds 300°F or drops below - 20°F. It will turn <u>OFF</u> when sensor temperature returns to the proper range. Yellow LED will be <u>ON</u> , if temperature exceeds 210°F. When either Red or Yellow LED is <u>ON</u> , heater will be shut down. 8)Check voltage across output and common terminals. If no 24V is present, replace board. 9)On Honeywell module, check voltage across terminals MV and MV/PV. If no 24V is present, replace module. If 24V is present, replace gas valve.



3) Pilot Outage. (Standing pilot models)	<ul style="list-style-type: none"> <li>1) Too low or too high gas pressures.</li> <li>2) Restricted pilot.</li> <li>3) Weak thermocouple.</li> </ul>	<ul style="list-style-type: none"> <li>1) Adjust inlet gas pressure as shown on rating plate.</li> <li>2) Clean pilot orifice.</li> <li>3) Replace thermocouple.</li> </ul>
4) Yellow lazy flame.	<ul style="list-style-type: none"> <li>1) Too low gas pressure.</li> <li>2) Restricted burner intake ports.</li> <li>3) Restricted gas line.</li> </ul>	<ul style="list-style-type: none"> <li>1) Adjust manifold pressure as shown on rating plate.</li> <li>2) Clean burners free of debris or insects.</li> <li>3) Clean gas line or increase gas line piping.</li> </ul>
5) Sooting	<ul style="list-style-type: none"> <li>1) Insufficient combustion air.</li> <li>2) Improper venting.</li> <li>3) Severe yellow burner flames.</li> </ul>	<ul style="list-style-type: none"> <li>1) Refer to installation instructions regarding combustion air requirements.</li> <li>2) Refer to installation instructions.</li> <li>3) See yellow flame section above.</li> </ul>

## ADJUSTMENTS/REPLACEMENTS OF COMPONENTS

**CAUTION:** Label all wires prior to disconnection when servicing controls. Wiring errors can cause improper and dangerous operation. Verify proper operation after servicing.

### DANGER - SHOCK HAZARD

Make sure electrical power to the heater is disconnected to avoid potential serious injury or damage to components.

#### 1. Gas Valve Replacement

- Shut off electrical power and gas supply to the heater.
- Remove gas piping to gas valve inlet.
- Disconnect wiring connections, pilot tubing (when equipped).
- Remove screws (2) holding the burner tray.
- Slide burner tray out.
- Remove gas valve bracket screws and bracket.
- Unscrew gas valve from gas pipe.
- Reverse above procedure to re-install.

#### 2. Pilot Burner Cleaning or Replacement (Standing Pilot)

- Shut off electrical power and gas supply to the heater.
- Disconnect gas piping to gas valve.
- Disconnect wiring connections to gas valve.
- Remove screws (2) holding the burner tray.
- Slide burner tray out.
- Remove screw holding pilot lighter tube.
- Remove screws (2) holding pilot bracket on the burner tray.
- Disconnect thermocouple and pilot tubing from the gas valve.
- Remove pilot burner from pilot bracket.
- Remove pilot orifice and blow away lint or dirt. Clean with wire or small brush.

**NOTE:** Make sure pilot orifice is clear, but do not enlarge the hole.

- Reverse above procedure to re-install.

#### HONEYWELL PILOT

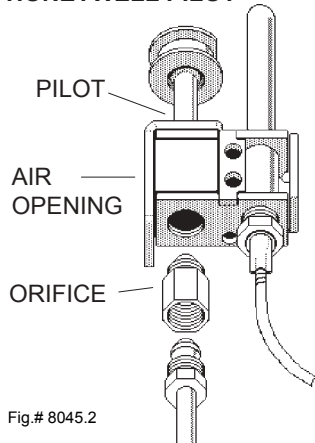

Fig.# 8045.2

#### ROBERTSHAW PILOT

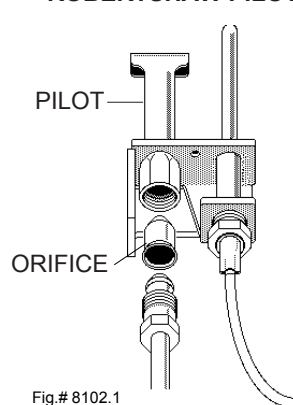

Fig.# 8102.1

#### 3. Flame Roll-out Switch Replacement

- Shut off electrical power to the heater.
- Remove wiring connections to switch.
- Remove screws (2) holding the switch.
- Reverse above procedure to re-install.

#### 4. Vent Thermal Switch Replacement

- Shut off electrical power to the heater.
- Remove wiring connections to switch.
- Remove the screws (2).
- Reverse above procedure to re-install.

#### 5. Ignition Module Replacement

- Shut off electrical power to the heater.
- Remove control cover screws and open control compartment.
- Disconnect wiring connections to module.
- Remove screws (2) holding module.
- Reverse above procedure to re-install.

#### 6. Transformer Replacement

- Shut off electrical power to the heater.
- Remove control cover screws and open control compartment.
- Disconnect wiring connections from transformer leads.
- Remove screws (2) holding transformer.
- Reverse above procedure to re-install.

#### 7. Circulator Replacement

- Shut off electrical power to the heater.
- Shut off water supply and open drain valve to remove water in the piping at the pump level.

**CAUTION:** To avoid damage to electrical components keep water from getting into the control compartments and gas valve.

- Disconnect wiring and conduit connections to the pump.
- Remove the nuts and bolts at the inlet and outlet flanges. Remove old gaskets.
- Remove the pump.
- Reverse the above procedure to re-install. Use new gaskets and make sure they are seated properly when tightening the nuts and bolts.

## 6. REPLACEMENT PARTS LIST

**NOTE:** *To supply the correct part it is important that you state the model number, serial number and type of gas when applicable.*

Any part returned for replacement under standard company warranties must be properly tagged with RAYPAK return parts tag, completely filled in with the heater serial number, model number etc., and shipped to the Company freight prepaid.

If determined defective by the Company and within warranty, the part will be returned in kind or equal substitution, freight collect. Credit will not be issued.

**RAYPAK, INC.**  
**2151 Eastman Avenue**  
**Oxnard, CA 93030**

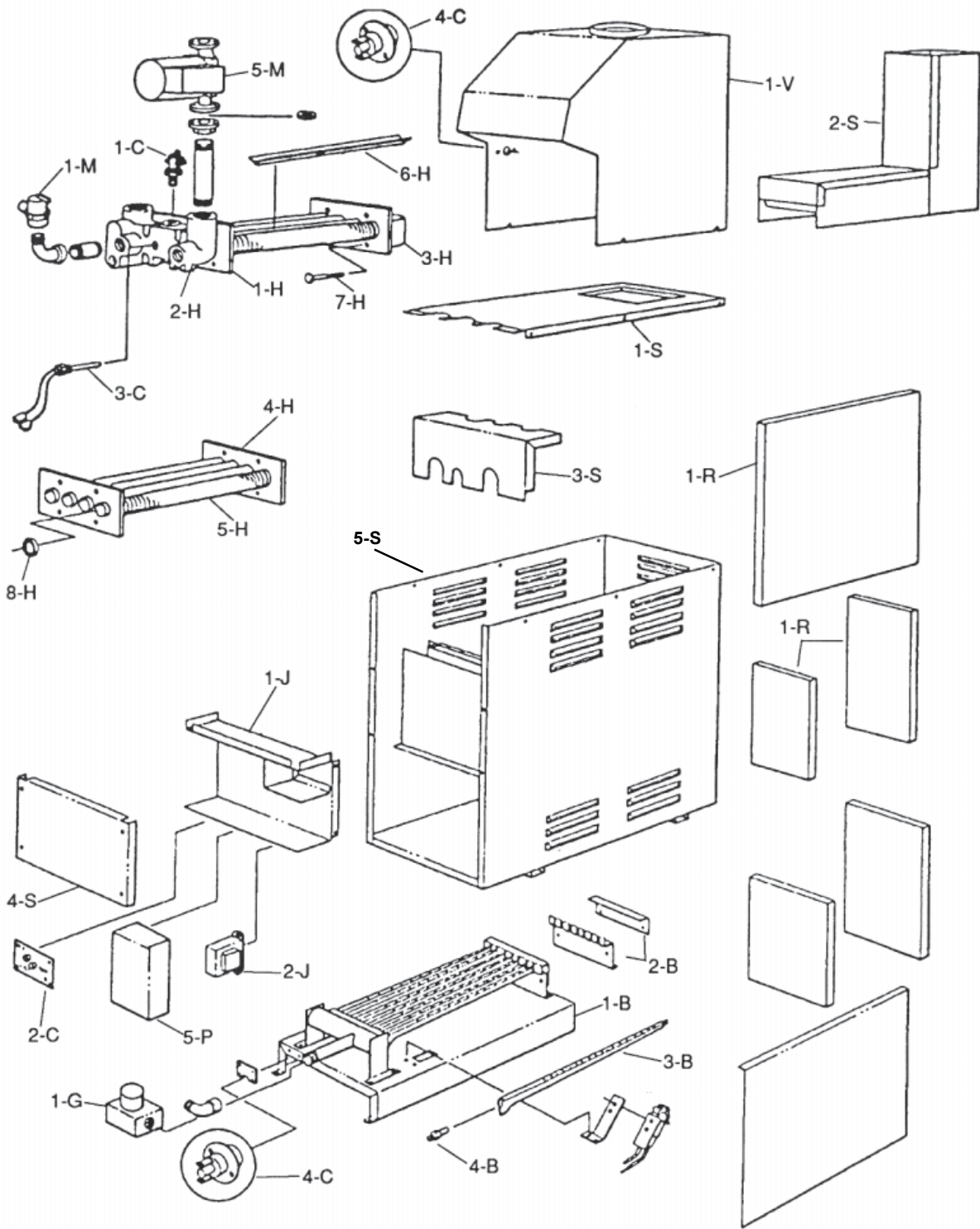

**HONEYWELL STANDING PILOT**

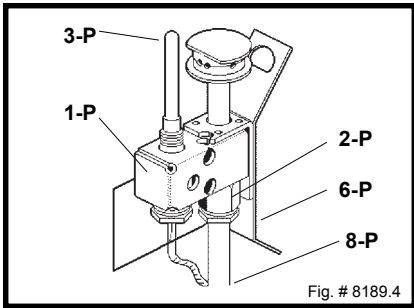

**HONEYWELL IID**

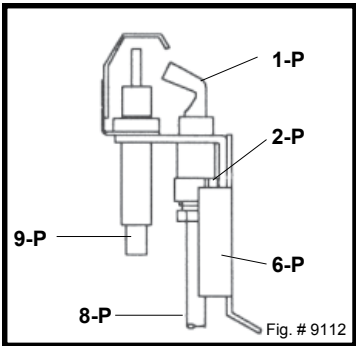

**ROBERTSHAW STANDING PILOT**

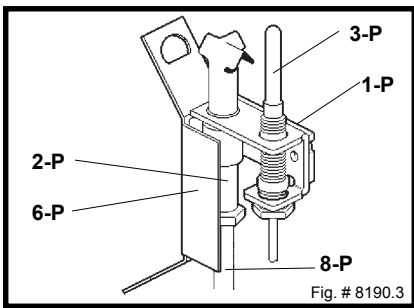

CALL OUT	DESCRIPTION	90	135	195
<b>B</b>	<b>BURNER TRAY</b>			
1-B	Burner Tray w/o Gas Valve (Sea Level)*	003940F	004227F	004228F
	Burner Tray w/Gas Valve Nat. STG	004769F	004805F	004793F
	Burner Tray w/Gas Valve Pro. STG	004770F	004806F	004794F
	Burner Tray w/Gas Valve Nat. IID	005455F	005964F	005966F
	Burner Tray w/Gas Valve Pro. IID	005456F	005965F	005967F
2-B	Burner Spacer/Hold-Down	003942F	004229F	004230F
3-B	Burner	301210/7	301210/11	301210/15
4-B	Burner Orifice Nat. (Sea Level)*	350079F/7	350079F/11	350079F/15
	Burner Orifice Pro. (Sea Level)*	350350F/7	350350F/11	350350F/15
<b>C</b>	<b>CONTROLS</b>			
1-C	Manual Reset Limit	008093F	008093F	008093F
2-C	Electronic Fast Response Sensor w/Probe	005555F	005555F	005555F
3-C	Probe Fast Response	601153	601153	601153
4-C	Roll-Out/Flue Sensor	006021F	006021F	006021F
5-C	Tankstat (Not Shown)	600179	600179	600179
<b>G</b>	<b>GAS VALVES</b>			
1-G	Combination Valve Nat. Std. Honeywell	601013	601013	601013
	Combination Valve Pro. Std. Honeywell	601014	601014	601014
	Combination Valve Nat. Std. Robertshaw	601009	601009	601009
	Combination Valve Pro. Std. Robertshaw	601010	601010	601010
	Combination Valve Nat. IID Honeywell	006957F	006957F	006957F
	Combination Valve Pro. IID Honeywell	006958F	006958F	006958F
	Combination Valve Nat. IID Robertshaw	005461F	005461F	005461F
	Combination Valve Pro. IID Robertshaw	005462F	005462F	005462F
<b>H</b>	<b>HEAT EXCHANGER</b>			
1-H	Heat Exchanger Cast Iron	005556F	005557F	005558F
2-H	Inlet/Outlet Header Cast Iron	005559F	005560F	005561F
3-H	Return Header Cast Iron	005562F	005563F	005564F
4-H	Tube Bundle	003960F	004243F	004244F
5-H	Heat Exchanger Tube	003961F	003961F	003961F
6-H	Baffle Kit	003964F	004245F	004246F
7-H	Carriage Bolt Kit	003965F	004247F	004248F
	Stud Bolt Kit	007912F	007911F	007911F
8-H	Header Gasket	800203B	800203B	800203B
<b>J</b>	<b>CONTROL BOX</b>			
1-J	Control Box Std. (Complete)	005565F	005566F	005566F
	Control Box IID Nat. (Complete)	005567F	005568F	005568F
2-J	Transformer	650691	650691	650691
<b>M</b>	<b>MISCELLANEOUS</b>			
1-M	PRV 125 PSI	008091F	008091F	008091F
2-M	Delimiting Kit	052871F	052871F	052871F
5-M	Pump Inline Taco	007325F	007327F	007327F
7-M	Pump Cartridge	951166F	951153F	951153F
6-M	Wire/Harness Standing Pilot	005569F	005569F	005569F
	Wire Harness IID	005570F	005570F	005570F

\*FOR ALTITUDES ABOVE 2,000 FEET ABOVE SEA LEVEL, CONSULT FACTORY.



CALL OUT	DESCRIPTION	90	135	195
P	PILOT			
1-P	Pilot Nat. Std.	003972F	003972F	003972F
	Pilot Pro. Std.	003973F	003973F	003973F
	Pilot Nat. IID	005467F	005467F	005467F
	Pilot Pro. IID	005468F	005468F	005468F
2-P	Pilot Orifice Nat. Std.	003974F	003974F	003974F
	Pilot Orifice Pro. Std.	003975F	003975F	003975F
	Pilot Orifice Nat. IID	003903F	003903F	003903F
	Pilot Orifice Pro. IID	004308F	004308F	004308F
3-P	Pilot Thermocouple	600003	600003	600003
5-P	Ignition Control IID Honeywell	004935F	004935F	004935F
6-P	Pilot Mtg. Bracket Std./IID	306239	306239	306239
8-P	Pilot Tube	400275	400275	400275
9-P	High Tension Wire IID	002654B	002654B	002654B
	High Tension Wire w/Pilot Electrode	007864F	007864F	007864F
R	REFRACTORY			
1-R	Refractory Kit	003978F	004259F	004260F
S	SHEETMETAL			
1-S	Jacket-Top	003980F	004261F	004268F
2-S	Flue Collector	003982F	004262F	004263F
3-S	Access Panel	003983F	004264F	004264F
4-S	Control Panel Cover	003984F	004265F	004265F
5-S	Jacket-Left	009170F	009170F	009170F
	Jacket-Right	009171F	009171F	009171F
	Jacket-Rear	009172F	009173F	009173F
V	VENTING			
1-V	Draffhood	003986F	004266F	004267F

GAS CONVERSION KITS**	90	135	195
HONEYWELL GAS VALVE			
Standing Pilot Nat. to Pro.	004277F		
Standing Pilot Pro. to Nat.	004278F		
IID Nat. to Pro. Honeywell	005477F	006084F	006086F
IID Pro. to Nat. Honeywell	005478F	006085F	006087F
ROBERTSHAW GAS VALVE			
Standing Pilot Nat. to Pro.	004297F	006076F	006078F
Standing Pilot Pro. to Nat.	004298F	006077F	006079F
IID Nat. to Pro. Robertshaw	005485F	006080F	006082F
IID Pro. to Nat. Robertshaw	005486F	006081F	006083F

\*\*GAS CONVERSIONS ARE TO BE DONE ONLY BY A QUALIFIED AGENCY.



**LIMITED PARTS WARRANTY ECONOPAK WATER HEATERS  
MODELS WH - 90 TO 195**

**SCOPE:**

Raypak, Inc. ("Raypak") warrants to the original owner that all parts of this water heater which are actually manufactured by Raypak will be free from failure under normal use and service for the specified warranty periods and subject to the conditions set forth in this Warranty. Labor charges and other costs for parts removal or reinstallation, shipping and transportation are not covered by this Warranty but are the owner's responsibility.

**HEAT EXCHANGER WARRANTY:**

- Five (5) Years from date of water heater installation. This includes only the copper, bronze and cast iron waterways.
- Twenty (20) Years from date of water heater installation against "Thermal Shock" (excluded, however, if caused by operation at large changes exceeding 150°F between the water temperature at intake and water heating temperature, or operating at water heater temperatures exceeding 190°F).

**ANY OTHER PART MANUFACTURED BY RAYPAK:**

One (2) year warranty from date of installation, or eighteen (18) months from date of factory shipment based on Raypak's records, whichever comes first.

SATISFACTORY PROOF OF INSTALLATION DATE, SUCH AS INSTALLER INVOICE, IS REQUIRED. THIS WARRANTY WILL BE VOID IF THE WATER HEATER RATING PLATE IS ALTERED OR REMOVED.

**ADDITIONAL WARRANTY EXCLUSIONS:**

This warranty does not cover failures or malfunctions resulting from:

1. Failure to properly install, operate or maintain the water heater in accordance with our printed instructions provided;
2. Abuse, alteration, accident, fire, flood and the like;
3. Sediment or lime buildup, freezing, or other conditions causing inadequate water circulation;
4. High velocity flow exceeding water heater design rates;
5. Failure of connected systems devices, such as pump or controller;
6. Use of non-factory authorized accessories or other components in conjunction with the water heater system;
7. Failing to eliminate air from, or replenish water in, the connected water system;
8. Chemical contamination of combustion air or use of chemical additives to water.

**PARTS REPLACEMENT:**

Under this Warranty, Raypak will furnish a replacement for any failed part. The failed part must first be returned to Raypak if requested, with transportation charges prepaid, and all applicable warranty conditions found satisfied. The replacement part will be warranted for only the unexpired portion of the original warranty. Raypak makes no warranty whatsoever on parts not manufactured by it, but Raypak will apply any such warranty as may be provided to it by the parts manufacturer.

**TO MAKE WARRANTY CLAIM:**

Promptly notify the original installer, supplying the model and serial numbers of the unit, date of installation and description of the problem. The installer must then notify his Raypak distributor for instructions regarding the claim. If either is not available, contact Service Manager, Raypak, Inc., 2151 Eastman Avenue, Oxnard, CA 93030 or call (805) 278-5300. In all cases proper authorization must first be received from Raypak before replacement of any part.

**EXCLUSIVE WARRANTY - LIMITATION OF LIABILITY:**

This is the only warranty given by Raypak. No one is authorized to make any other warranties on Raypak's behalf. THIS WARRANTY IS IN LIEU OF ALL OTHER WARRANTIES, EXPRESS OR IMPLIED, INCLUDING BUT NOT LIMITED TO IMPLIED WARRANTIES OF MERCHANTABILITY AND FITNESS FOR A PARTICULAR PURPOSE. RAYPAK'S SOLE LIABILITY AND THE SOLE REMEDY AGAINST RAYPAK WITH RESPECT TO DEFECTIVE PARTS SHALL BE AS PROVIDED IN THIS WARRANTY. IT IS AGREED THAT RAYPAK SHALL HAVE NO LIABILITY, WHETHER UNDER THIS WARRANTY, OR IN CONTRACT, TORT, NEGLIGENCE OR OTHERWISE, FOR ANY SPECIAL, CONSEQUENTIAL, OR INCIDENTAL DAMAGE, INCLUDING DAMAGE FROM WATER LEAKAGE. Some states do not allow limitations on how long an implied warranty lasts, or for the exclusion of incidental or consequential damages. So the above limitation or exclusion may not apply to you.

This Limited Warranty gives you specific legal rights. You may also have other rights which may vary from state to state. We suggest that you complete the information below and retain this certificate in the event warranty service is needed. Reasonable proof of the effective date of the warranty (date of installation) must be presented, otherwise, the effective date will be based on the rate of manufacture plus thirty (30) days.

\_\_\_\_\_  
Name of Owner

\_\_\_\_\_  
Name of Dealer

\_\_\_\_\_  
Address

\_\_\_\_\_  
Address

\_\_\_\_\_  
Model No.

\_\_\_\_\_  
Serial No.

Date of Installation: \_\_\_\_\_

Date of Initial Operation: \_\_\_\_\_

CORPORATE HEADQUARTERS:

RAYPAK, INC., 2151 Eastman Avenue, Oxnard, CA 93030 (805) 278-5300 FAX (805) 278-5489



[www.raypak.com](http://www.raypak.com)

**Raypak, Inc.**, 2151 Eastman Avenue, Oxnard, CA 93030 (805) 278-5300 FAX (800) 872-9725  
**Raypak Canada LTD**, 2805 Slough Street, Mississauga, Ontario, Canada L4T 1G2 (905) 677-7999 FAX (905) 677-8036  
Litho in U.S.A.

## Free Manuals Download Website

<http://myh66.com>

<http://usermanuals.us>

<http://www.somanuals.com>

<http://www.4manuals.cc>

<http://www.manual-lib.com>

<http://www.404manual.com>

<http://www.luxmanual.com>

<http://aubethermostatmanual.com>

Golf course search by state

<http://golfingnear.com>

Email search by domain

<http://emailbydomain.com>

Auto manuals search

<http://auto.somanuals.com>

TV manuals search

<http://tv.somanuals.com>