

SAFETY PRECAUTIONS



The lightning flash with an arrowhead within a triangle alerts you to the presence of important to uninsulated dangerous voltage within the product's enclosure that could cause an electric shock.

The exclamation point within a triangle alerts you to the presence of important operating, maintenance and servicing instructions in this user's manual.

The symbol for Class II (Double Insulation)

WARNING:
TO REDUCE THE RISK OF ELECTRIC SHOCK, DO NOT REMOVE COVER (OR BACK). NO USER-SERVICEABLE PARTS INSIDE. REFER SERVICING TO QUALIFIED PERSONNEL. TO PREVENT FIRE OR SHOCK HAZARD, DO NOT EXPOSE THIS UNIT TO RAIN OR MOISTURE. THE UNIT SHALL NOT BE EXPOSED TO DRIPPING OR SPLASHING AND THAT NO OBJECTS FILLED WITH LIQUIDS, SUCH AS VASES, SHALL BE PLACED ON UNIT. TO BE COMPLETELY DISCONNECT THE POWER INPUT, THE MAINS PLUG OF UNIT SHALL BE DISCONNECTED FROM THE MAINS.

THE MAINS PLUG OF UNIT SHOULD NOT BE OBSTRUCTED OR SHOULD BE EASILY ACCESSED DURING INTENDED USE. **CAUTION:** BATTERY SHALL NOT BE EXPOSED TO EXCESSIVE HEAT SUCH AS SUNSHINE, FIRE OR THE LIKE. SHOULD ANY PROBLEMS OCCUR, DISCONNECT THE AC POWER CORD AND REFER SERVICING TO A QUALIFIED TECHNICIAN. DO NOT PLACE ANYTHING DIRECTLY ON TOP OF THE UNIT, IT MAY CAUSE DAMAGE.

Placement Information

- Do not use this unit in places which are extremely hot, cold, dusty, or humid.
- In a cabinet, allow about 2.5cm (1 inch) of free space around the unit for adequate ventilation.
- Place the unit on a flat and even surface.
- Do not restrict the air flow of this unit by placing

it somewhere with poor air flow, by covering it with a cloth, or by placing it on bedding or carpeting.

Safety Information

- When connecting or disconnecting the AC power cord, grip the plug and not the cord itself. Pulling the cord may damage it and create a hazard.

- When you are not going to use the unit for a long period of time, disconnect the AC power cord.

Condensation Information

- When left in a heated room where it is warm and damp, water droplets or condensation may form inside the unit. When there is condensation inside the unit, the unit may not function normally. Let the unit stand for 1-2 hours before turning the power on, or gradually heat the room and let the unit dry before use.

Rating Plate Location
The rating plate is located on the rear of unit.

FCC Statements
NOTE: This equipment has been tested and found to comply with the limits for a Class B digital device, pursuant to Part 15 of the FCC Rules. These limits are designed to provide reasonable protection against harmful interference in a residential installation. This equipment generates, uses and can radiate radio frequency energy and, if not installed and used in accordance with the instructions, may cause harmful interference

WARNING:
CHANGES OR MODIFICATIONS TO THIS UNIT NOT EXPRESSLY APPROVED BY THE PARTY RESPONSIBLE FOR COMPLIANCE COULD VOID THE USER AUTHORITY TO OPERATE THE EQUIPMENT.

IMPORTANT SAFETY INSTRUCTIONS

- Read these instructions.
- Keep these instructions.
- Heed all warnings.
- Follow all instructions.
- Do not use this apparatus near water.
- Clean only with dry cloth.
- Do not block any ventilation openings. Install in accordance with the manufacturer's instructions.
- Do not install near any heat sources such as radiators, heat registers, stoves, or other apparatus (including amplifiers) that produce heat.
- Do not defeat the safety purpose of the polarized or grounding-type plug. A polarized plug has two blades with one wider than the other. A grounding type plug has two blades and a third grounding prong. The wide blade or the third prong are provided for your safety. If the provided plug does not fit into your outlet, consult an electrician for replacement of the obsolete outlet.
- Protect the power cord from being

walked on or pinched particularly at plugs, convenience receptacles, and the point where they exit from the apparatus.

- Only use detachments/accessories specified by the manufacturer.
- Use only with the cart, stand, tripod, bracket, or table specified by the manufacturer, or sold with the apparatus. When a cart is used, use caution when moving the cart/apparatus combination to avoid injury from tip-over.
- Unplug this apparatus during lightning storms or when unused for long periods of time.
- Refer all servicing to qualified service personnel. Servicing is required when the apparatus has been damaged in any way, such as power-supply cord or plug is damaged, liquid has been spilled or objects have fallen into the apparatus, the apparatus has been exposed to rain or moisture, does not operate normally, or has been dropped.

GETTING STARTED

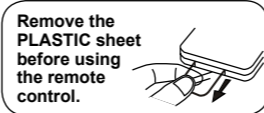

TO CHANGE THE REMOTE CONTROL BATTERY

- Open the battery door.
- Insert one CR2025 (3V) size battery.



Using the Remote Control

- Point the remote control at the REMOTE SENSOR located on the unit.
- When using this unit in very bright light, the infrared REMOTE CONTROL SENSOR may not work properly.
- The recommended maximum distance for using the remote control is about 16 feet (5 meters).

BATTERY REPLACEMENT

When the battery becomes weak, the operating distance of the remote control will be greatly reduced and you will need to replace the battery.

Note: If the remote control is not going to be used for a long time, remove the battery.

WARNING: Do not dispose of the battery in a fire or it may leave and/or explode.

CAUTION: Danger of explosion if battery is incorrectly replaced. Replace only with the same or equivalent type.

REFERENCE GUIDE

REMOTE CONTROL

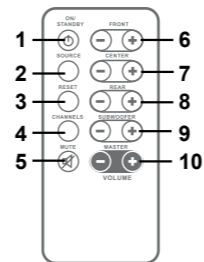

- ON/STANDBY button**
- SOURCE button**
Switches the sound input source (between DVD IN, LINE IN or AUX IN) press repeatedly to select different sources.
- RESET button**
Adjusts all speakers to their original factory default settings.

REFERENCE GUIDE

UNIT - Front

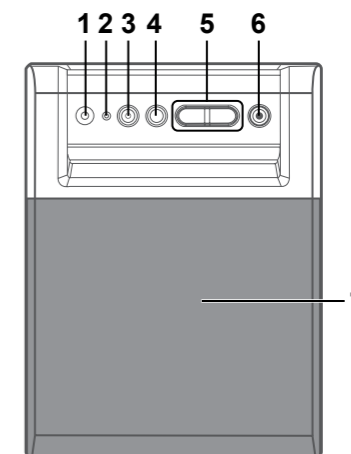

- Remote Control Sensor**
- STANDBY indicator**
Green Light : the unit is in turned ON. Amber Light : the unit is in STANDBY.
- ON/STANDBY button**
- SOURCE button**
Switches the sound input source (between DVD IN, LINE IN or AUX IN). Press repeatedly to select different sources.
- VOLUME +/- buttons**
Adjusts the volume and the level of all speakers.
- LINE IN jack**
Connects to the Audio Out of portable audio players or other audio devices
- SUBWOOFER**

UNIT - Rear

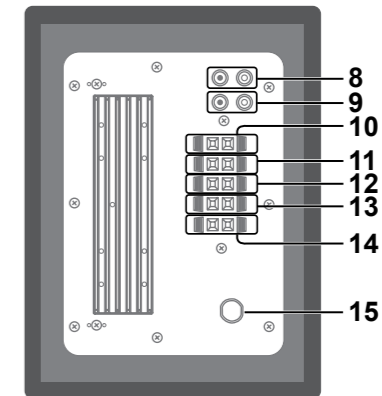

- DVD IN jack**
Connects to the Audio Out of DVD player, VCR, etc.
- AUX IN jack**
Connects to the Audio Out of TV or other audio devices.
- FRONT Left Speaker terminal**
- FRONT Right Speaker terminal**
- CENTER Speaker terminal**
- SURROUND Left Speaker terminal**
- SURROUND Right Speaker terminal**
- POWER CORD**

CONNECTIONS

1. POWER CONNECTION

Note :

- Before you plug in the unit, make sure that the rated voltage of your unit matches your local voltage.
- Keep your hands dry when you are connecting the power cord to the wall outlet to avoid electric shock.
- When you are not going to use the unit for a long period of time, disconnect the power cord.

- When the player is in the standby mode, it is still consuming some power. If you wish to disconnect the unit completely from the power, unplug the power cord from the AC outlet.
- TO PREVENT ELECTRIC SHOCK, MATCH WIDE BLADE OF PLUG TO WIDE SLOT, FULLY INSERT.**

2. CONNECTING THE SPEAKERS & SUBWOOFER

IMPORTANT :
Switch off the power before connecting equipment.
The speakers cords have been color-coded to simplify connection. Just plug the speaker wire into the corresponding jacks on the rear of the unit, matching the color tube on the end of the speaker wire to the color-coded connector.

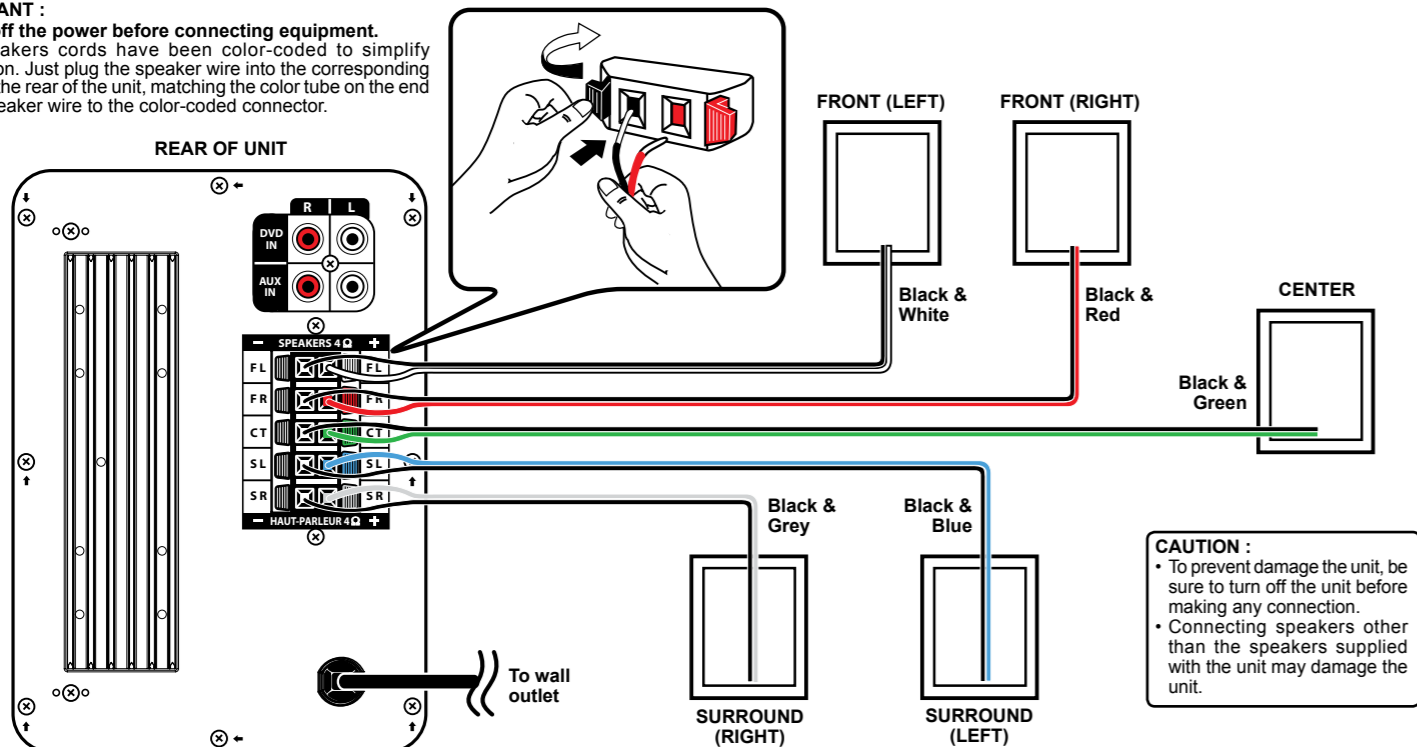

CAUTION :

- To prevent damage the unit, be sure to turn off the unit before making any connection.
- Connecting speakers other than the speakers supplied with the unit may damage the unit.

CONNECTIONS

3. SPEAKERS POSITIONING

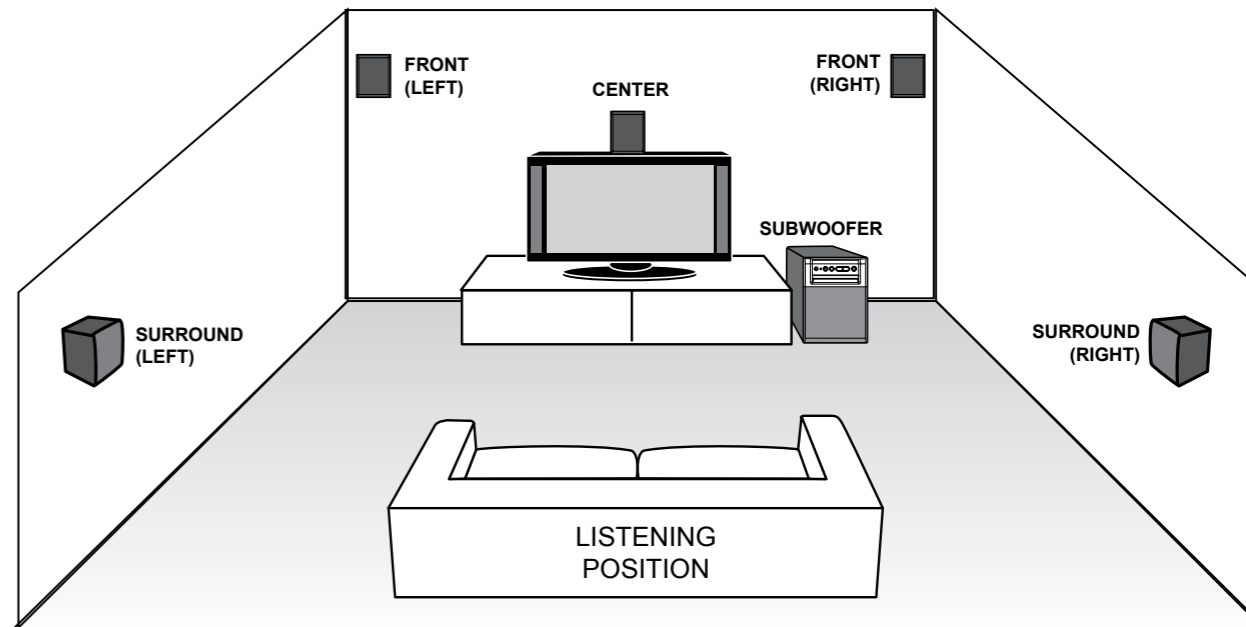

CONNECTIONS

4. CONNECTING TO TV

- Connect the audio cable to the white jack of AUX IN (L) and red jack of AUX IN (R) on the rear of unit, and then connect to the corresponding AUDIO OUT jacks on your TV.
- Turn on your TV. This will allow your TV's sound to play through the unit.
- Press the **SOURCE** button to select AUX IN mode. You should now hear your TV's audio over your Home Theater's speakers. If you don't:
 1. Please check the volume settings on both your Home Theater and your TV.
 2. For some TV's (this is quite rare) you may need to ensure your TV's Audio Output is enabled (see TV's setup menu).

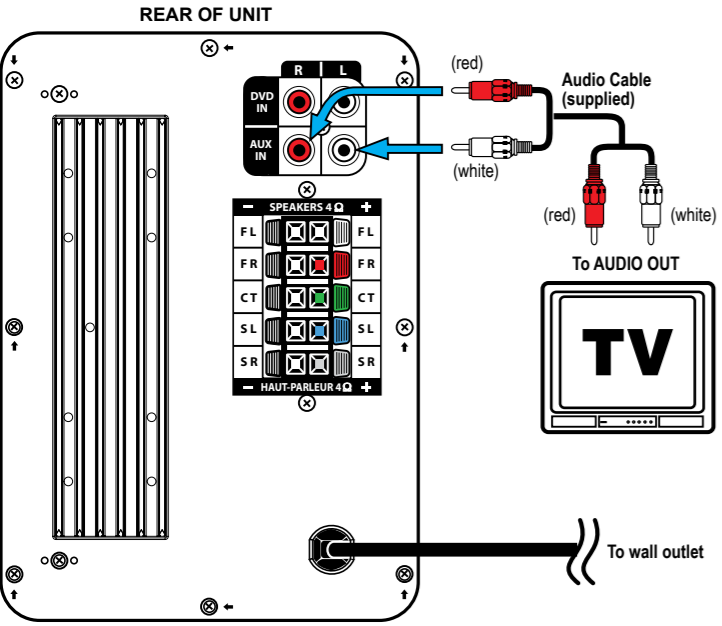

E - 7

5. CONNECTING TO DVD PLAYER / VCR / GAME CONSOLE / VIDEO CAMERA

- Connect the audio cable to the white jack of DVD IN (L) and red jack of DVD IN (R) on the rear of unit, and then connect to the corresponding AUDIO OUT jacks on your DVD PLAYER / VCR / Game Console / Video Camera.
- Turn on DVD PLAYER, VCR, Game Console or Video Camera. This will allow your DVD PLAYER / VCR / Game Console / Video Camera's sound to play through the unit.
- Press the **SOURCE** button to select DVD IN mode.

NOTE : In order to have TV sound come through this Home Theater System, your TV must have AUDIO OUT jacks. These jacks will typically be located on the rear or side of the TV (not in the front). Most, but not all TV's have these Audio Out jacks.

NOTE: If you use a Cable or Satellite Box to view TV content, you should be able to use the Audio Out connection on the Cable or Satellite Box to listen to TV audio through your Home Theater. Simply connect to the Home Theater's AUX IN.

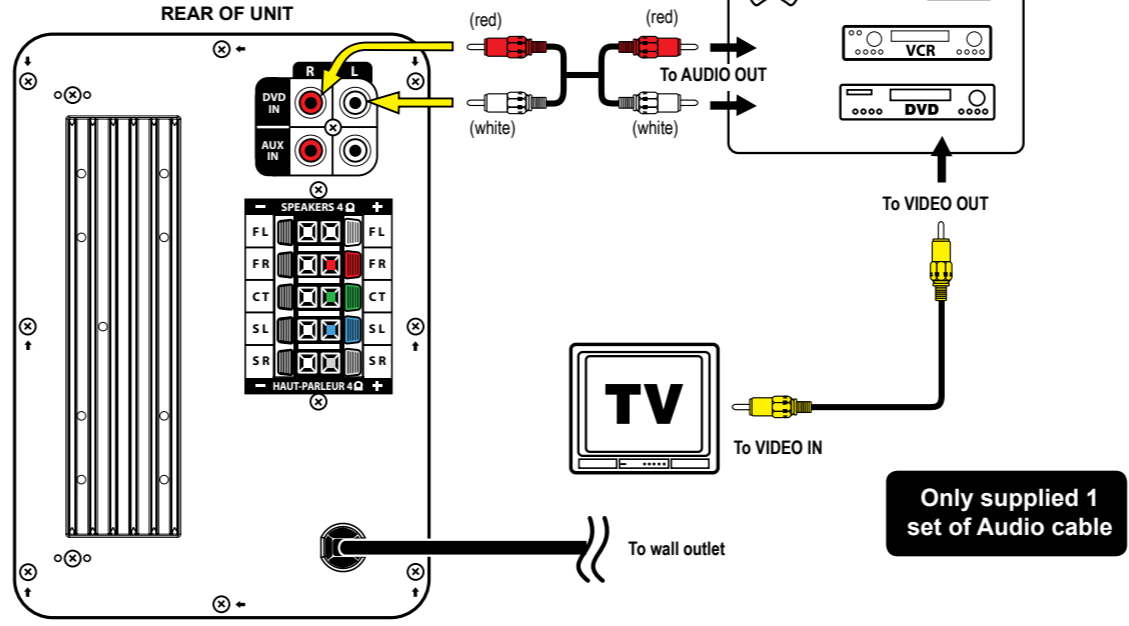

E - 8

CONNECTIONS

6. CONNECTING TO OTHER EQUIPMENT

- Connect an audio cable to the LINE IN jack on the front of unit and the jack of AUDIO OUT/HEADPHONE of your equipment.
- Turn on your other equipment. This will allow your equipment's sound to play through the unit.
- Press the **SOURCE** button to select LINE IN mode.

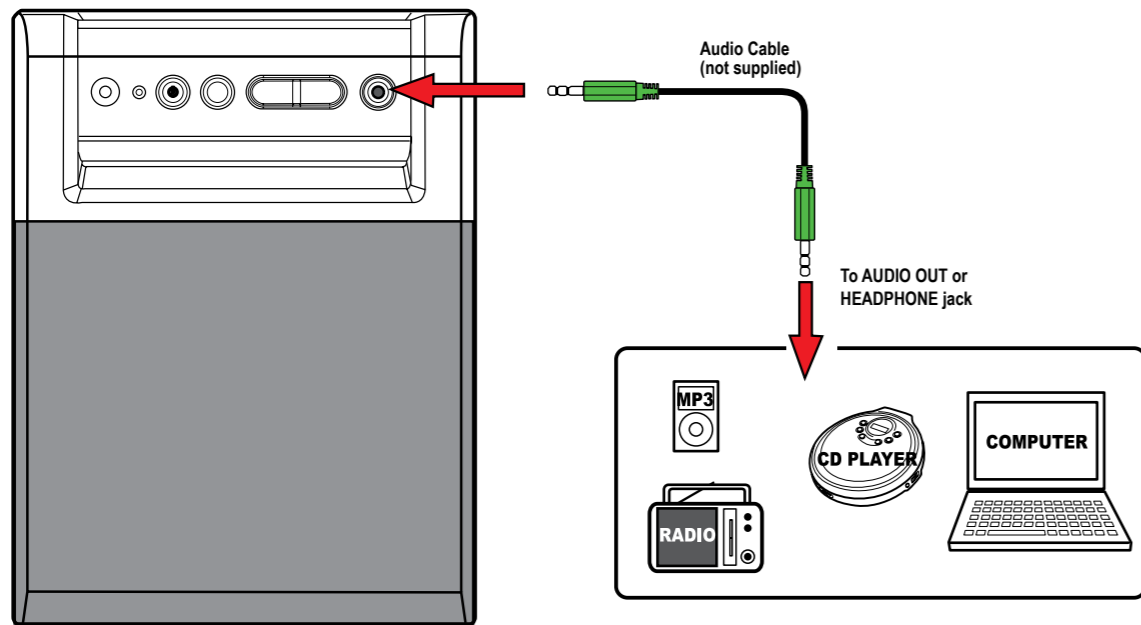

E - 9

SOUND ADJUSTMENT

TO ADJUST THE MASTER VOLUME

- Point the remote control at the REMOTE SENSOR located on the unit.
- Press the **VOLUME +/-** buttons on the unit or the **VOLUME MASTER +/-** button on the remote control to adjust the level of all speakers.

TO ADJUST THE VOLUME OF INDIVIDUAL SPEAKER

- Point the remote control at the REMOTE SENSOR located on the unit.
- Directly press the **+** or **-** button on the remote control to increase or decrease the level of the corresponding speaker(s).

TO RESET

- Press the **RESET** button on the remote control to return to factory default speaker settings.

TO CHANGE THE SPEAKER CHANNEL

- Press the **CHANNELS** button on the remote control to select the listening mode. This will switch between 5.1 (SURROUND MODE) and 2.1 (STEREO with SUBWOOFER). We recommend you leave system in 5.1 mode. The Center and Rear Surround speakers will not be active if system is in STEREO mode.

Note:

- Surround speakers and center speaker volume adjustments can only be made from the remote control in 5.1 channel speaker mode, not in 2.1 channel speaker mode.
- Press the **MUTE** button to turns off the sound instantly. Press again to restore the sound.

SPECIFICATIONS

Power requirement : AC ~ 120V 60Hz
 Power Consumption : 35W

E - 10

TROUBLE SHOOTING GUIDE

SYMPTOM	CAUSE AND SOLUTION
No power.	• Check that the AC power cord is connected.
No sound.	• Press the VOLUME + button to increase volume. • Ensure the MUTE button is not pressed on the remote control. • Ensure the SOURCE selection is correct.
No sound from one channel or unbalanced left and right volume.	Try pressing the RESET button on remote control. If this doesn't help, try pressing the CHANNEL button on remote control (this will switch system between 5.1 SURROUND and STEREO modes). • Check the speaker connections of the inoperative channel. • Check the speaker cord connection and speaker location. • Adjust individual speaker volumes.
Reversed left and right sound.	• Check the speaker connection for proper phasing.
The center speaker or the surround speakers give no sound.	• Check the speaker connections are correct. • The current mode does not support surround sound.
The remote control does not function.	• Remove any obstacles between the remote control and the unit. • Use the remote control near the unit. • Point the remote control at the remote sensor on the unit. • Replace the battery in the remote control with new one. • If there is a clear plastic strip sticking out from the rear of the remote control, pull it out.

LIMITED WARRANTY

AVC MULTIMEDIA ("AVC") makes the following limited warranty. These limited warranties extend to the original consumer purchaser and is limited to non-commercial user of the product.

One Year Parts & Labor Warranty

AVC products purchased in the United States are warranted to be free from defects in materials or workmanship for a period of one year from the date of their original retail purchase. If the unit fails to conform to this warranty, we will service the product using new or refurbished parts and products, at AVC's sole discretion.

During a period of one year from the effective warranty date, **AVC** will provide, when needed, service labor to repair a manufacturing defect at its designated Service Center. To obtain warranty service in the United States, you must first call our **Customer Support Center at 1-877-252-6873, during the hours listed in the box below.** The determination of service will be made by AVC customer support.

PLEASE DO NOT RETURN YOUR UNIT TO AVC WITHOUT PRIOR AUTHORIZATION.

New or remanufactured replacements for defective parts or products will be used for repairs by **AVC** at its designated Service Center for one year from the defective warranty date. Such replacement parts or products are warranted for an additional one year from the date of repair or replacement. The Customer will be required to ship the unit to the Service Center indicated at the time Customer Support is contacted to make the necessary repairs. The customer is responsible for all transportation charges to the service facility.

Packaging and Shipping Instruction

When you send the product to the **AVC** service facility you must use the original carton box and packing material or an equivalent as designated by **AVC**.

Your Responsibility

- (1) You must retain your bill of sale to provide proof of purchase.
- (2) These warranties are effective only if the product is purchased and operated in the U.S.A. or Canada.
- (3) Warranties extend only to defects in material or workmanship, and do not extend to any product or parts which have been lost or discarded, or damage to product or parts caused by misuse, accident, improper operation or maintenance, or use in violation of instructions provided with the product, or to product which has been altered or modified without authorization of **AVC**, or to products or parts thereof which have had the serial number removed or changed.

Out of Warranty

In the event your product requires repair after the limited warranty period has expired, please contact our Customer Support Center at **1-877-252-6873** or **www.RCAav.com**
 Hours: Monday-Thursday: 9am-7pm, Friday: 9am-5pm, Saturday: 9am-NOON Eastern time.
Important:
 You are responsible for any transportation, shipping or insurance relative to the return of the product to our Product Returns Center.

All warranties implied by state law, including the implied warranties of merchantability and fitness for a particular purpose, are expressly limited to the duration of the limited warranties set forth above. With the exception of any warranties implied by state law as hereby limited, the foregoing warranty is exclusive and in lieu of all other warranties, guarantees, agreements and similar obligations of manufacturer or seller with respect to the repair or replacement of any parts. In no event shall **AVC** be liable for consequential or incidental damages.

No person, agent, distributor, dealer or company is authorized to change, modify or extend the terms of these warranties in any manner whatsoever. The time within action must be commenced to enforce any obligation of **AVC** arising under the warranty or under any statute, or law of the United States or any state thereof, is hereby limited to one year from the date of purchase. This limitation does not apply to implied warranties arising under state law.

This warranty gives you specific legal rights and you may also have other rights, which may vary from state to state. Some states do not allow limitation on how long an implied warranty lasts, when an action may be brought, or the exclusion or limitation of incidental or consequential damages, so the above provisions may not apply to you.

For more information on other products and services, please contact our web site at **www.RCAav.com**

Important: Also keep your "Bill of Sale" as proof of purchase.

Model no. Product name

Type of set

Serial no. Invoice no.

Date purchased Dealer name

FOR SERVICE AND REPAIR, PLEASE VISIT **www.RCAav.com**

Free Manuals Download Website

<http://myh66.com>

<http://usermanuals.us>

<http://www.somanuals.com>

<http://www.4manuals.cc>

<http://www.manual-lib.com>

<http://www.404manual.com>

<http://www.luxmanual.com>

<http://aubethermostatmanual.com>

Golf course search by state

<http://golfingnear.com>

Email search by domain

<http://emailbydomain.com>

Auto manuals search

<http://auto.somanuals.com>

TV manuals search

<http://tv.somanuals.com>