

RCA THOMSON

U
S
E
R
M
A
N
U
A
L



IMPORTADOR
Comercializadora Thomson de México, S.A. de C.V.
Miguel de Cervantes Saavedra 57
Col. Ampliación Granada
C.P. 11529 Mexico D.F.
Telefono: (55)25 81 53 20
RFC: CTM-980723-KS5

0151

Thomson multimedia Inc.
P.O. Box 1976
Indianapolis, IN 46206-1976
© 2002 Thomson multimedia Inc.
Trademark(s) © Registered
Marca(s) © Registrada(s)
Marque(s) © Déposé(e)
55654460 (EN/F/E)
www.rca.com
www.rca.com/LatinAmerica
Printed In China / Impreso en China

RP2461/RP2462/
RP2463/RP2467/
LAD899U

IT IS IMPORTANT TO READ THIS INSTRUCTION BOOK PRIOR TO USING YOUR NEW PRODUCT FOR THE FIRST TIME.
ES IMPORTANTE LEER ESTE MANUAL ANTES DE USAR POR VEZ PRIMERA SU EQUIPO.

SAFETY INFORMATION

EN

CAUTION!

Invisible laser radiation when open. Avoid exposure to beam. Class I laser product. This system must be opened only by qualified technicians to prevent accidents caused by the laser beam.

LASER $\lambda = 780 \text{ nm}$, $P_{\text{max}} = 5 \text{ mW}$
 Rating Information: At bottom of the unit this unit comply with the existing requirements

In accordance with the rating plate of the unit, this unit complies with current standards concerning electrical safety and electromagnetic compatibility.



ADVARSEL!
 USYNLIG LASERSTRÅLING VED ÅBNING NÅR SIKKERHEDSÅFTRYKERE ER UDE AF FUNKTION. UNØDNE UDGAETTELSE FOR STRÅLING.
 VORSICHT!
 UNSICHTBARE LASERSTRALUNG WENN ABDECKUNG GEÖFFNET UND SICHERHEITSVERREGELUNG ÜBERBRÜCKT. NICHT DEM LASERSTRAHL AUSSETZEN!

CAUTION - INVISIBLE LASER RADIATION WHEN OPEN AND INTERLOCKS FAILED OR DEFEATED. AVOID EXPOSURE TO BEAM.
 ATTENTION - RAYONNEMENT LASER INVISIBLE DANGEREUX EN CAS D'OUVERTURE ET LORSQUE LA SECURITE EST NEUTRALISEE. EXPOSITION DANGEREUSE AU FAISCEAU.



CLASS I LASER PRODUCT
 LASER KLASSE I
 APPAREIL A LASER DE CLASSE I
 LUOKAN I LASERLAITE
 KLASSE I LASERAPPARAT

WARNING - OSYNLIG LASERSTRÅLING NÅR DENNA DEL ÅR ÖPPNAD OCH SPÄRRAN ÅR URKOPPLADE. BETRÄKTA EJ STRÅLEN.
 VARI!
 HUOMIATTAESSA JA SOJULUKITUSOHITETTAESSA OLET ALLTIHINA NÄKYMÄTTÖMÄLLE. LASERATEITTYLLE ÄLÄ KÄYSO SÄTTESEEN.

 THE LIGHTNING FLASH AND ARROW-HEAD WITHIN THE TRIANGLE IS A WARNING SIGN ALERTING YOU OF "DANGEROUS VOLTAGE" INSIDE THE PRODUCT.

CAUTION
 RISK OF ELECTRICAL SHOCK
 DO NOT OPEN
 CAUTION: TO REDUCE THE RISK OF ELECTRICAL SHOCK, DO NOT REMOVE COVER (OR BACK). NO USER-SERVICEABLE PARTS INSIDE. REFER SERVICING TO QUALIFIED SERVICE PERSONNEL.

 THE EXCLAMATION POINT WITHIN THE TRIANGLE IS A WARNING SIGN ALERTING YOU OF IMPORTANT INSTRUCTIONS ACCOMPANYING THE PRODUCT.

WARNING: TO PREVENT FIRE OR ELECTRICAL SHOCK HAZARD, DO NOT EXPOSE THIS PRODUCT TO RAIN OR MOISTURE.

FCC INFORMATION

FCC Information

This device complies with Part 15 of the FCC Rules. Operation is subject to the following two conditions: (1) This device may not cause harmful interference, and (2) this device must accept any interference received, including interference that may cause undesired operation. In accordance with FCC requirements, changes or modifications not expressly approved by Thomson multimedia Inc. could void the user's authority to operate this product.

This device generates and uses radio frequency (RF) energy, and if not installed and used properly, this equipment may cause interference to radio and television reception.

If this equipment does cause interference to radio or television reception (which you can determine by unplugging the unit), try to correct the interference by one or more of the following measures:

- Re-orient the receiving antenna (that is, the antenna for the radio or television that is "receiving" the interference).
- Move the unit away from the equipment that is receiving interference.
- Plug the unit into a different wall outlet so that the unit and the equipment receiving interference are on different branch circuits.

If these measures do not eliminate the interference, please consult your dealer or an experienced radio/television technician for additional suggestions. Also, the Federal Communications Commission has prepared a helpful booklet, "How To Identify and Resolve Radio TV Interference Problems." This booklet is available from the U.S. Government Printing Office, Washington, DC 20402. Please specify stock number 004-000-00345-4 when ordering copies. This product complies with DHHS Rules 21 CFR Subchapter J. Applicable at the date of manufacture.

For Your Records

In the event that service should be required, you may need both the model number and the serial number. In the space below, record the date and place of purchase, and the serial number:
 Model No.
 Date of Purchase
 Place of Purchase
 Serial No.

Service Information

This product should be serviced only by those specially trained in appropriate servicing techniques. For instructions on how to obtain service, refer to the warranty included in this Guide.

Technical specification

Product: Personal CD Player
 Brand: RCA
 Model: RP2461 / RP2462 / RP2463 / RP2467

Electrical Consumption
 Power Supply: 120V-60Hz
 Power consumption: 6 Watts

IMPORTER
 Comercializadora Thomson de México,
 S.A. de C.V.
 Miguel de Cervantes Saavedra 57
 Col. Ampliación Granada
 C.P. 11529 Mexico D.F.
 Telefono: (55)25 81 53 20
 RFC: CTM-980723-K55

This Class B digital apparatus complies with Canadian ICES-003.
 Cet appareil numérique de la class B est conforme à la norme du NMB-003 du Canada

EN

Table of Content

EN

Safety Information / FCC Information

Before You Begin2

Unpacking Your Unit2

How to use your Clip Phones2

General Control3

Power Supply4

AC Outlet Power Supply4

Car (DC) Power Supply Adaptor
(For RP2467 only)4

Battery Power Supply4

The CD Player5

Display5

Listening to Compact Disc5

Playback5

Skip/Search6

Pause6

Stop6

Lock6

Listening to a CD in your car
(For RP2467 only)6

Resume7

Repeating / Intro Scan7

Random Playback7

Remain Time7

Bass Boost7

Program8

Edit Program8

Exit Program Mode8

Cancel Program8

More Information9

Useful Advice9

Notes on CD-R/RW Discs9

Please Respect The Environment10

Headset Safety10

Technical Specification10

U.S. Warranty11

Canadian Warranty13

Before You Begin

EN

Unpacking Your Unit

You should have the following:

- one main unit
- one remote control
- one carrying strap
- one set of clip phones
- one user's guide

How to Use Your Clip Phones (The e.clipz)

The right ear clip phone is labeled R while the left ear clip phone is labeled L.

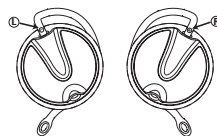

1. Pull the ear hook away from the ear pad slightly. You will hear a click sound.

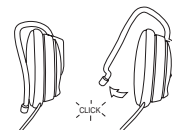

2. Slide the ear hook behind the ear with the ear pad on the front of the ear.

Rotate the clip phone so the ear pad fits closely with the ear.

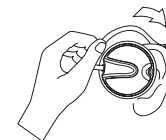

3. Lock the clip phone in place by pushing down on the top of the ear hook until it locks.

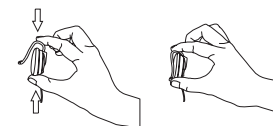

4. For best sound quality, make sure the earpad fits closely with your ear.



General Control

EN

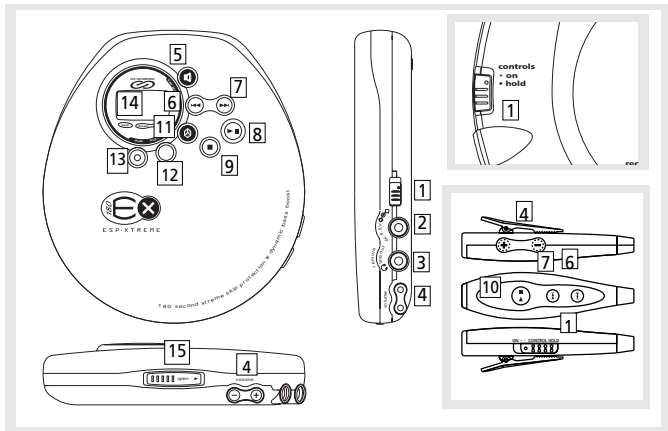

1. **control** switch - To lock or unlock the buttons.
2. DC jack - You can insert the adapter instead of batteries for indoor use.
3. **Line Out /** **Headphones Jack/remote** - Insert your headphones here.
4. **volume + / -** buttons - To adjust the volume.
5. **bass boost** - Selects bass boost options.
6. - Skip / search backward track.
7. - Skip / search forward track.
8. **Play/Pause** button - Press to play or pause CD.
9. **Stop** button- Press to stop CD play.
10. (remote control only) - Plays and ends CD playback.
11. - For random playback.
12. **prog display** button - Enters program mode, or changes playback display.
13. **mode** button - For repeat or introscan function.
14. Display Panel - More information on Page 5.
15. **open** switch - Slide to open CD door.

3

Power Supply

EN

Model Number	AC/DC Adaptor	Batteries
RP2461 / RP2462 / RP2463 / RP2467	5-4079B (not included) Required Rating: Input: 120VAC 60Hz 6.0W Output: 4.5VDC @ 600mA	AAx2 (Not Included)
LAD899U	A30460B (Included) (230V 50Hz)	2 x 1.5V IEC R6 (UM3) (Included) AAx2 (Included)

AC Outlet Power Supply (supplied with LAD899U only)

You can power your CD player with an AC/DC adaptor. Refer to the table for details of the operating voltage. AC/DC adaptor is purposed for indoor use in dry rooms only. Remove the jack from the device to use it with the batteries.

Note : Power is fed to the unit even when it is not functioning. To cut the power supply off, the AC/DC adaptor must be unplugged.

Car (DC) Power Supply Adaptor (For RP2467 only)

Plug the car (DC) power supply adaptor into the DC in 4.5V jack at the rear/side of the CD player & then into the cigarette lighter receptacle in your car

Battery Power Supply

Refer to the table for details of the batteries required to operate your unit.

Recharge function (For LAD899U only)

- To charge Ni-Cd batteries:
1. Insert 2 rechargeable batteries into the battery compartment on the main unit.
 2. Connect the main adaptor.
 3. Press **STOP** on the unit to start recharging. An animated battery indicator will be displayed when recharging is in progress.

4

THE CD PLAYER

EN THE DISPLAY

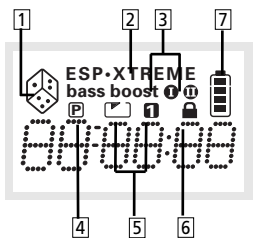

1. Random Playback
2. ESP•XTREME - 180 sec ESP
ESP - 45 sec ESP
3. Is displayed when Bass Boost is ON.
Press Bass Boost momentarily to toggle between Bass Boost 1, Bass Boost 2 and off.
4. Program mode
5. Repeat entire disc or repeat current track.
6. Is displayed when the control button is on HOLD position.
- 7 Battery Indicator.

5

Listening to a Compact Disc

Slide the **open** switch to the right to open the door. Insert a disc and press lightly on the centre to lock. Close the door.

Playback

Press Play/Pause button on the main unit or Play/Stop on the remote control to start playback.

Rd DISC will appear in the display. Then, the total number of tracks and time of the CD will be displayed. If the disc compartment is empty or the disc cannot be played, No Disc will appear in the display.

The **EXTREME SKIP PROTECTION* (EPS)** system prevents sound interruptions when impacts or vibrations occur. Extreme skip protection consumes less power and increases the battery life. Therefore, the **ESP** function is always **ON**.

After many successive impacts, the buffer might be emptied causing a brief sound interruption for the memory to reload.

ESP•XTREME (180 seconds buffer) - Press Play/Pause on the main unit or Play/Stop on the remote control to power on the unit. The display will show ESP•XTREME.

ESP (45 seconds buffer) - For better listening quality, press **prog•display** while pressing Play/Pause to turn the unit on. The display will show ESP.

THE CD PLAYER

EN

Skip /Search

Press to skip to the previous track. Press and hold to search backwards in a track.

Press to skip to the next track. Press and hold to search forward in a track.

Pause

Press Play/Pause on the main unit again to pause playback. The minutes and seconds flash when interrupted

Stop

Press Stop on the main unit or Play/Stop on the remote control during playback to end CD playback.

Lock

Slide **control** switch on the main unit to **HOLD** position to lock the button on the main unit to avoid accidental activation of unwanted functions. The hold icon will show on the display when the controls are locked.

Do the same to lock the buttons on the remote control.

NOTE: Remember to slide the CONTROL switch to ON position to activate the controls again.

Listening to a CD in your car (For RP2467 only)

1. Select a power source (either battery power or the car DC adaptor)
2. Insert the cassette adaptor into the tape deck and plug the cord into the CD player's HEADPHONES jack.
3. Insert a compact disc and press Play/ Pause button to power on the unit (180 sec ESP). Press and hold **prog•display** while you press Play/Pause to turn on the unit for 45 sec ESP setting. Adjust CD player's volume to a mid level (make sure the Bass Boost is turned off).
4. Use the car stereo to adjust volume, tone. Adjust the volume of your CD player for better volume control.
5. Before ejecting the cassette after you have finished listening, make sure the car stereo's volume is turned down.

6

THE CD PLAYER

EN

Resume

When you power off the unit (without disconnecting power supply), Resume is automatically activated. It stores the following settings and modes: Mode (Repeat/Repeat All/ Random) and EQ setting (Bass Boost). When play mode is on again, the unit resumes to the settings.

To automatically store current track when you stop CD play, press **STOP** button twice.

Repeating/Intro scan

You can replay the entire CD or one track as many times as you wish as well as listen to the beginning of each track for 10 seconds.

Press **mode** successively to

1. Replay the entire CD .
2. Replay the current track.
3. Play the beginning of each track for 10 seconds.(The number of the track being played will be displayed and SCAN will display.)
4. Press again to de-select the function.

7

Random Playback

1. Press Play/Pause ►|| on the main unit or Play/Stop ►■ on the remote control to start playback.
2. Press  to activate random playback function.
3. Press again to cancel the function.

Remain Time

Press **prog•display** on the main unit when CD is playing to toggle between displaying track elapse time and disc remain time.
(Available in normal playback mode only)

Bass Boost

Press bass boost  repeatedly to select bass boost I and bass boost II.

THE CD PLAYER

EN

Program

This function lets you listen to the tracks you selected in the order you want. You can program up to 24 tracks. The CD player must be in Stop mode.

1. Press and hold **prog•display** to enter program mode. P icon will appear in the display.
2. Press ►► or ◀◀ to select the track to store.
3. Press **prog•display** to confirm your entry.
4. Repeat steps 2 and 3 to store other tracks.
5. Press Play/Pause button ►|| to listen to your programming.

Edit Program

To add/edit tracks to the program, enter stop mode.

1. Press and hold **prog•display** button to display program information.
2. Press **prog•display** repeatedly to select the program location to edit.
3. Press ►► or ◀◀ to select the new track to store into selected memory location.
4. Press **prog•display** to confirm your entry.
5. Press Play/Pause ►|| to start program playback.

Cancel Program

To cancel your program, press and hold the **mode** key when you are in the stop mode. ERASE will appear in the display. The program will be automatically canceled.

Exit Program mode

To exit program mode, press **prog•display** in stop mode.

Note : To prevent excessive battery consumption, the unit switches off automatically in all modes after 30s if no key has been activated.

8

More Information

EN

Clean the player with a soft cloth, or a damp chamomis leather. Never use solvents.

USEFUL ADVICE

- Do not store CDs in damp areas.
- Do not expose CDs to high temperatures.
- Do not put any tape or adhesives on either side of the disc.
- You should avoid leaving the CD door open. Dust is liable to impair performance of the laser optical unit.
- Do not use your set immediately after transport from a cold place to a warm place: there may be condensation problems.
- Do not touch the playing surface. Make sure that you keep your set away from water and high temperatures.
- If you do not use your set on battery power for more than one month, we advise you to take out all the batteries.
- To prevent personal injury, do not reverse any battery and do not mix battery types.
- Discard leaking batteries immediately. Leaking batteries can cause skin burns or other personal injury.
- This apparatus shall not be exposed to dripping and splashing.

- Thomson recommends Duracell Ultra Batteries.

Caution: Charge batteries if the switch at the back of the unit is ON (for Thomson Model only). Do not attempt to charge when recharge switch is OFF, you may damage the unit and batteries.

- Prolonged use of the CD player at full volume can damage the user's ear.

SPC: Sound Pressure Control at 100dB maximum (only for Thomson models)

Notes on CD-R/RW Discs

- Do not affix any type of labels to either side (recordable or labeled side) of a CD-R/RW disc as this may result in the unit malfunctioning.
- To avoid damages to the CD-R/RW disc, do not open the disc compartment door while the disc is being read.
- Do not load an unrecorded CD-R/RW disc into the unit. This may take a longer time to read the disc.
- Playback capability for CD-RW discs may vary due to variations in the quality of the CD-RW disc and the recorder used to create the disc.

9

More Information

PLEASE RESPECT THE ENVIRONMENT !



Before throwing any batteries away, consult your distributor who may be able to take them back for specific recycling.

Headset Safety



Have a Blast- Just Not in Your Eardrums
Make sure you turn down the volume on the unit before you put on headphones. Increase the volume to the desired level

only after headphone is in place.

- Do not play your headset at high volume. Hearing experts warn against extended high-volume play.
- If you experience ringing in your ears, reduce volume or discontinue use.
- You should use with extreme caution or temporarily discontinue use in potentially hazardous situations.

Even if your headset is an open-air designed to let you to hear outside sounds, do not turn up the volume so high that you are unable to hear what is around you.

EN

TECHNICAL SPECIFICATIONS

* Frequency response: 20Hz to 20kHz

Power Supply

- 4.5V DC (through AC/DC adaptor (refer to table page 4 for details)
- 2 "AA" batteries (Duracell Ultra recommended)
- 2 "AA" rechargeable Ni-cd batteries (Recharge function on Thomson models)
- 4.5V DC (through car DC adaptor)

10

U.S. Warranty

EN

What your warranty covers:

- Defects in materials or workmanship.

For how long after your purchase:

- One year from date of purchase.
The warranty period for rental units begins with the first rental or 45 days from date of shipment to the rental firm, whichever comes first.

What we will do:

- Provide you with a new, or at our option, a refurbished unit. The exchange unit is under warranty for the remainder of the original product's warranty period.
- Proof of purchase in the form of a bill of sale or receipted invoice which is evidence that the product is within the warranty period must be presented to obtain warranty service. For rental firms, proof of first rental is also required.

How to make a warranty claim:

- Properly pack your unit. Include any cables, etc., which were originally provided with the product. We recommend using the original carton and packing materials.
- Include evidence of purchase date such as the bill of sale. Also print your name and address and a description of the defect. Send via standard UPS or its equivalent to:

Thomson multimedia Inc.
Product Exchange Center
11721 B Alameda Avenue
Socorro, Texas 79927

- Insure your shipment for of loss or damage. Thomson accepts no liability in case of damage or loss en route to Thomson.
- Pay any charges billed to you by the Exchange Center for service not covered by the warranty.
- A new or refurbished unit will be shipped to you freight prepaid.

What your warranty does not cover:

- Customer instruction. (Your Owner's Manual provides information regarding operating Instructions and user controls. For additional information, ask your dealer.)
- Installation and set-up service adjustments.
- Batteries.
- Damage from misuse or neglect.
- Products which have been modified or incorporated into other products.
- Products purchased or serviced outside the USA.
- Acts of nature, such as but not limited to lightning damage.

Product Registration:

- Please complete and mail the Product registration Card packed with your unit. It will make it easier to contact you should it ever be necessary. The return of the card is not required for warranty coverage.

U.S. Warranty

EN

Limitation of Warranty:

- THE WARRANTY STATED ABOVE IS THE ONLY WARRANTY APPLICABLE TO THIS PRODUCT. ALL OTHER WARRANTIES, EXPRESS OR IMPLIED (INCLUDING ALL IMPLIED WARRANTIES OF MERCHANTABILITY OR FITNESS FOR A PARTICULAR PURPOSE) ARE HEREBY DISCLAIMED. NO VERBAL OR WRITTEN INFORMATION GIVEN BY THOMSON MULTIMEDIA INC., ITS AGENTS OR EMPLOYEES SHALL CREATE A WARRANTY OR IN ANY WAY INCREASE THE SCOPE OF THIS WARRANTY.
- REPAIR OR REPLACEMENT AS PROVIDED UNDER THIS WARRANTY IS THE EXCLUSIVE REMEDY OF THE CONSUMER. THOMSON MULTIMEDIA INC. SHALL NOT BE LIABLE FOR INCIDENTAL OR CONSEQUENTIAL DAMAGES RESULTING FROM THE USE OF THIS PRODUCT OR ARISING OUT OF ANY BREACH OF ANY EXPRESS OR IMPLIED WARRANTY ON THIS PRODUCT. THIS DISCLAIMER OF WARRANTIES AND LIMITED WARRANTY ARE GOVERNED BY THE LAWS OF THE STATE OF INDIANA. EXCEPT TO THE EXTENT PROHIBITED BY APPLICABLE LAW, ANY IMPLIED WARRANTY OF MERCHANTABILITY OR FITNESS FOR A PARTICULAR PURPOSE ON THIS PRODUCT IS LIMITED TO THE APPLICABLE WARRANTY PERIOD SET FORTH ABOVE.

How state law relates to this warranty:

- Some states do not allow the exclusion nor limitation of incidental or consequential damages, or limitations on how long an implied warranty lasts, so the above limitations or exclusions may not apply to you.
- This warranty gives you specific legal rights, and you also may have other rights that vary from state to state.

If you purchased your product outside the USA:

- This warranty does not apply. Contact your dealer for warranty information.

Canadian Warranty

EN

Thomson multimedia Ltd. warrants to the purchaser or gift recipient that if any manufacturing defect becomes apparent in this product within 1 year from the original date of purchase, it will be replaced free of charge, including return transportation.

This warranty does not include damage to the product resulting from accidents, misuse or leaking batteries.

Should your product not perform properly during the warranty period, either:

1. Return it to the selling dealer with proof of purchase for replacement,

OR

2. Remove the batteries (where applicable), and pack product complete with accessories in the original carton (or equivalent).

— Mail prepaid (with proof of purchase) and insured to:

Thomson multimedia Ltd.

6200 Edwards Blvd.,

Mississauga, Ontario,

L5T 2V7

Canada

The provisions of this written warranty are in addition to and not a modification of or subtraction from the statutory warranties and other rights and remedies contained in any applicable legislation, and to the extent that any such provisions purport to disclaim, exclude or limit any such statutory warranties and other rights and remedies, such provisions shall be deemed to be amended to the extent necessary to comply therewith.

If you are unable to find a qualified servicer for out of warranty service, you may write to:

Thomson multimedia Inc.

P.O. Box 0944

Indianapolis, Indiana, U.S.A., 46206-0944

Attach your sales receipt to this booklet for future reference. This information is required if service is needed during the warranty period.

PURCHASE DATE

NAME OF STORE

Free Manuals Download Website

<http://myh66.com>

<http://usermanuals.us>

<http://www.somanuals.com>

<http://www.4manuals.cc>

<http://www.manual-lib.com>

<http://www.404manual.com>

<http://www.luxmanual.com>

<http://aubethermostatmanual.com>

Golf course search by state

<http://golfingnear.com>

Email search by domain

<http://emailbydomain.com>

Auto manuals search

<http://auto.somanuals.com>

TV manuals search

<http://tv.somanuals.com>