

owner's manual

STA-3850 STEREO RECEIVER



RCA

INTRODUCTION

Your RCA STA-3850 Stereo Receiver operates as the perfect control center for your audio system. It combines 50 watts-per-channel of clean power with modern styling. It provides connections for one tape deck, a turntable, a CD player, and one other audio source, such as audio from a digital video disk (DVD) player. You can also connect up to two pairs of speakers (not supplied) to your receiver.

Additional features include:

Digital-Synthesized Tuner — Precisely tunes to AM and FM stations.

60 Memory Locations — Let you store and recall the frequencies for up to 30 AM and 30 FM stations.

Automatic Tuning — Searches for the next available AM/FM station.

Tape Monitoring — Lets you listen to the actual recording as you record, if your tape deck has a tape-monitoring feature.

Built-In Protection Circuits — Automatically turn off the receiver to help avoid power surges or short circuit damage.

Remote Control — Lets you use a single remote control for the receiver and other compatible components connected to the receiver.

Note: The remote control requires two AA batteries (not supplied).

We recommend you record the receiver's serial number here. The number is on the receiver's back panel.

Serial Number: _____.

WARNING: To reduce the risk of fire or shock hazard, do not expose this product to rain or moisture.



CAUTION

RISK OF ELECTRIC SHOCK.
DO NOT OPEN.



CAUTION: TO REDUCE THE RISK OF ELECTRIC SHOCK, DO NOT REMOVE COVER OR BACK. NO USER-SERVICEABLE PARTS INSIDE. REFER SERVICING TO QUALIFIED PERSONNEL.



This symbol is intended to alert you to the presence of uninsulated dangerous voltage within the product's enclosure that might be of sufficient magnitude to constitute a risk of electric shock. Do not open the product's case.



This symbol is intended to inform you that important operating and maintenance instructions are included in the literature accompanying this product.

Caution: Unplug the cassette deck's power cord when you will not use the cassette deck for extended periods.

FCC NOTICE

This system complies with the limits for a Class B digital device as specified in Part 15 of *FCC Rules*. These limits provide reasonable protection against radio and TV interference in a residential area. However, your equipment might cause TV or radio interference even when it is operating properly. To eliminate interference, you can try one or more of the following corrective measures:

- Reorient or relocate the receiving antenna.
- Increase the distance between the equipment and the radio or TV.
- Use outlets on different electrical circuits for the equipment and the radio or TV.

Consult your local RadioShack store if the problem still exists.

Warning: Changes or modifications to this unit not expressly approved by RadioShack could void the user's authority to operate the equipment.

IMPORTANT SAFETY INSTRUCTIONS

Careful attention is devoted to quality standards in the manufacture of your cassette deck, and safety is a major factor in its design. However, safety is also your responsibility.

This section lists important information that will help you properly use and enjoy your cassette deck. **Read all the included safety and operating instructions before using your cassette deck.** Follow them closely, and retain them for future reference.

Heed Warnings — Follow all warnings on the product and in the operating instructions.

Cleaning — Unplug this product from the wall outlet before cleaning. Use only a damp cloth for cleaning. Do not use liquid or aerosol cleaners.

Attachments — Do not use attachments/accessories not recommended by the product manufacturer, as they might create a hazard.

Water and Moisture — Do not use this product near water (for example, near a bathtub, washbowl, kitchen sink, or laundry tub; in a wet basement; or near a swimming pool).

Accessories — Do not place this product on an unstable cart, stand, tripod, bracket, or table. The product may fall, causing serious injury to a child or adult, and serious damage to the product. Use only with a cart, stand, tripod, bracket, or table recommended by the manufacturer or sold with the product. Follow the manufacturer's instructions for mounting, and use a recommended mounting accessory.



Carts — Move the product on a cart carefully. Quick stops, excessive force, and uneven surfaces may cause the product/cart to overturn.

Ventilation — Slots and openings in the cabinet provide ventilation, ensure reliable operation, and protect from overheating. Do not block or cover these openings, and do not place the product on a bed, sofa, rug, or other similar surface. Do not place the product in a built-in installation such as a bookcase or rack unless it provides proper ventilation as specified by the manufacturer.

Power Sources — Operate this product using only the power source indicated on its marking label. If you are not sure of your home's power type, consult your product dealer or local power company.

Polarization — This product is equipped with a polarized AC line plug (a plug having one blade wider than the other). This plug will fit in the power outlet only one way. This is a safety feature. If you cannot insert the plug fully into the outlet, try reversing the plug. If the plug still doesn't fit, contact your electrician to replace your obsolete outlet. Do not defeat the safety purpose of the polarized plug. If you need an extension, use a polarized cord.

Power-Cord Protection — Route power-supply cords so they are not likely to be walked on or pinched by items placed on or against them, paying particular attention to cords at plugs, convenience receptacles, and the point where they exit from the product.

Lightning — For added protection for this product during a lightning storm, or when it is left unattended and unused for long periods of time, unplug it from the wall outlet and disconnect the antenna or cable system. This will prevent damage to the product due to lightning and power-line surges.

Overloading — Do not overload wall outlets, extension cords, or integral convenience receptacles, as this can result in a risk of fire or electric shock.

Objects and Liquids — Never push objects of any kind into this product through openings, as they may touch dangerous voltage points or short out parts that could result in a fire or electric shock. Never spill liquid of any kind on the product.

Servicing — Do not attempt to service this product yourself, as opening or removing covers may expose you to dangerous voltage or other hazards. Refer all servicing to qualified service personnel.

Damage Requiring Service — Unplug this product from the wall outlet and refer servicing to qualified service personnel under the following conditions:

- When the power-supply cord or plug is damaged.
- If liquid has been spilled or objects have fallen into the product.
- If the product has been exposed to rain or water.
- If the product does not operate normally by following the operating instructions. Adjust only those controls that are covered by the operating instructions, as an improper adjustment of other controls may result in damage and will often require extensive work by a qualified technician to restore the product to normal operation.
- If the product has been dropped or damaged in any way.
- When the product exhibits a distinct change in performance.

Replacement Parts — When replacement parts are required, be sure the service technician uses replacement parts specified by the manufacturer or having the same characteristics as the original part. Unauthorized substitutions may result in fire, electric shock, or other hazards.

Safety Check — Upon completion of service or repairs to this product, ask the service technician to perform safety checks to determine that the product is in proper operating condition.

Wall or Ceiling Mount — The product should be mounted to a wall or ceiling only as recommended by the manufacturer.

Heat — The product should be situated away from heat sources such as radiators, heat registers, stoves, or other products (including amplifiers) that produce heat.

Non-use Periods — Unplug the cassette desk's power cord when you will not use it for extended periods.

CONTENTS

Preparation	5
Positioning Speakers	5
Connecting Speakers	5
Preparing the Speaker Wires	5
Connecting Speakers to the A and B Terminals	5
Connecting Program Sources	6
Connecting a Turntable	6
Connecting a CD Player	6
Connecting a Cassette Deck	6
Connecting Another Audio Source	6
Connecting the Antennas	6
AM Antennas	6
FM Antennas	7
Installing the Remote Control's Batteries	8
Connecting to AC Power	8
Operation	9
Using the Sleep Timer	9
Tuning the Radio	9
Manual and Automatic Tuning	9
Direct Tuning (Remote Control Only)	10
Memory Tuning	10
Automatically Storing Stations	10
Manually Storing a Station	10
Tuning to a Station in Memory	10
Adjusting Balance	11
Muting the Receiver	11
Using Headphones	11
Listening Safely	11
Cassette Deck Features	11
Using the Tape Monitor Button	11
Recording a Program Source	11
Using the Reset Button	11
Troubleshooting	12
Care and Maintenance	13
The FCC Wants You to Know	13
Specifications	14

PREPARATION

Caution: Make all the necessary connections before you plug in or turn on the receiver.

POSITIONING SPEAKERS

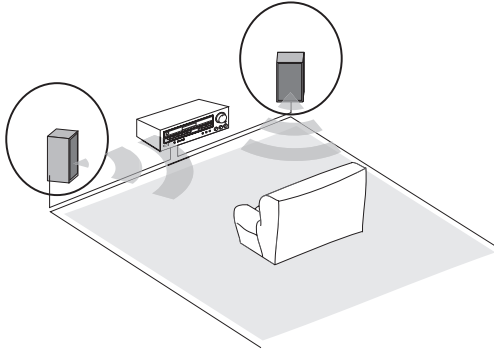

Speaker (not supplied) placement can make a noticeable difference in your system's sound. The guidelines in this section will help you choose the best locations. After you use your receiver for a while, you might want to try different locations for your speakers.

Bass response depends largely on speaker location. For strong bass, place the speakers in the corners of the room. If you want even stronger bass, place the speakers directly on the floor. If the bass is too strong, move the speakers slightly away from the corners of the room, or raise them 6 to 18 inches off the floor. You can buy speaker stands at your local RadioShack store.

The distance between the speakers should be about the same as the distance between the normal listening point and the point halfway between the speakers. If you place the speakers too close together, you reduce the stereo separation. If you place them too far apart, you reduce the bass effect and create a *hole* in the middle of the sound.

Most speakers have a tweeter dispersion angle of about 60 degrees. Ideally, your listening position should be just inside the overlap area of the tweeter dispersion. You can angle the speakers toward you for better stereo effect.

CONNECTING SPEAKERS

Follow these guidelines when you select and connect speakers.

- Only connect speakers that are rated at between 8 and 16 ohms.
- Be sure you properly connect all speakers.
- Do not connect two pairs of speakers to a single set of terminals (A or B) at the same time. When you use two pairs of speakers, connect one pair to the A SPEAKERS

terminals and the other pair to the B SPEAKERS terminals.

- Optimus, and other high-quality speakers have color-coded speaker terminals (red for positive polarity and black for negative polarity). Use these color-coded terminals as a guide to help you properly connect the speakers to the receiver.

Use 16-gauge (or larger) speaker wire for all speaker connections, and consider possible speaker locations before you decide how much speaker wire you need.

Preparing the Speaker Wires

Speaker wire consists of two conductors (individual wires) encased in insulation and is usually color-coded or marked with a ridge along one side so you can identify each conductor. Use these markings as a guide to help you properly connect the speakers to your receiver.

Follow these steps to prepare the speaker wires.

1. Cut the speaker wires to the necessary length.
2. Separate the wires about 4 inches on each end.
3. Using a wire stripper, carefully strip about $\frac{3}{4}$ inch of insulation from the end of each conductor.
4. Twist the end of each conductor to secure any loose wire strands.

Caution: Twisting the end of each conductor helps prevent a short circuit because stray speaker wire strands do not touch other speaker terminals or any other receiver terminals.

Connecting Speakers to the A and B Terminals

Note:

- Be sure you connect the receiver's right and left positive (+) and negative (-) terminals to the speaker's corresponding right and left positive (+) and negative (-) terminals.
- Fully insert the speaker wires to ensure a good connection. Leave extra wire at the back of the receiver so you do not disconnect the wires when you move the receiver.

Follow these steps to connect each speaker (A right or left or B right or left).

1. Press open the receiver's positive (+) red lever for the speaker you want to connect and insert the ridged or color-coded conductor's end into the small hole. Release the lever to secure the conductor.

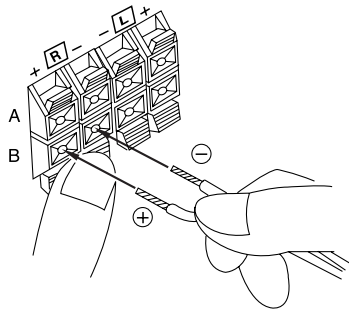

2. Press open the receiver's negative (-) black lever for the same speaker and insert the other conductor's end into the small hole. Release the lever to secure the conductor.
3. Connect the ridged or color-coded conductor's loose end to the speaker's positive (+) terminal.
4. Connect the remaining loose conductor to the speaker's negative (-) terminal.

CONNECTING PROGRAM SOURCES

Note: Use shielded audio cables with phono connectors for all audio connections.

You can connect up to four external program sources to your receiver.

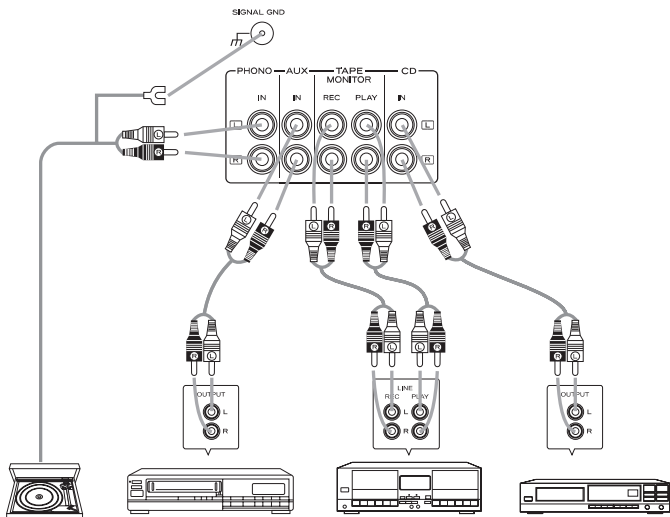

Connecting a Turntable

Connect a turntable with a magnetic cartridge only. Some older turntables use a ceramic-type cartridge that does not work with this system.

Connect the turntable's left and right cables to the receiver's **L** (left) and **R** (right) **PHONO IN** jacks. Then connect the

turntable's ground wire to the receiver's **GND** screw terminal.

Connecting a CD Player

To connect a CD player to the receiver, connect the CD player's left and right output jacks to the receiver's **L** and **R CD IN** jacks.

Connecting a Cassette Deck

You can connect a cassette deck to the **TAPE MONITOR** jacks. Connect the cassette deck's output jacks to the **PLAY** jacks, and connect the cassette deck's input jacks to the **REC** jacks.

Connecting Another Audio Source

Connect the audio outputs of another audio source, such as the audio from a laser disc player, TV, or VCR to the **AUX** jacks.

CONNECTING THE ANTENNAS

In many areas, the supplied indoor AM loop and FM antennas provide satisfactory reception.

AM Antennas

Assemble the supplied AM antenna's base by swinging the base in the direction of the arrow and inserting the antenna's bottom tabs into the base's slot. If the receiver is in a rack or on a shelf and there is no room for the AM loop antenna, use two screws (not supplied) to mount the base on the wall or another location as shown.

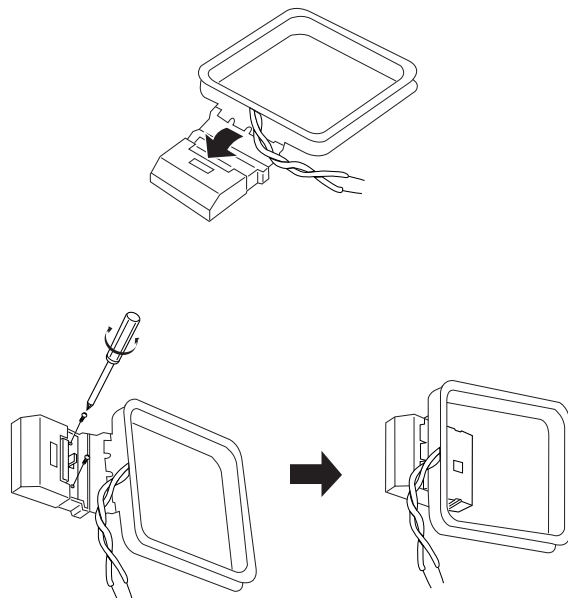

Attach the antenna wires from the AM loop antenna to the **AM** and **GND** (ground) **ANTENNA** terminals.

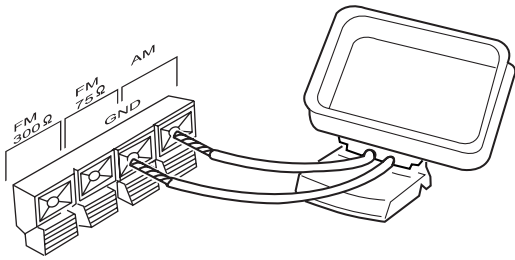

Place the antenna on a flat surface and rotate it for the best AM reception.

Notes:

- Keep the AM loop antenna connected even when you use another indoor antenna or an outdoor AM antenna.
- Ensure that the antenna does not touch the receiver or any other metal object.
- Do not place the antenna near a CD player, a personal computer, or a TV set.
- If the wire between the AM loop antenna and your receiver is too short, you can add extra wire, available at your local RadioShack store.

You can also use an optional RadioShack shortwave antenna kit (Cat. No. 278-758), which makes an excellent outdoor AM antenna. Connect the outdoor AM antenna wire to the receiver's **AM ANTENNA** terminal as shown.

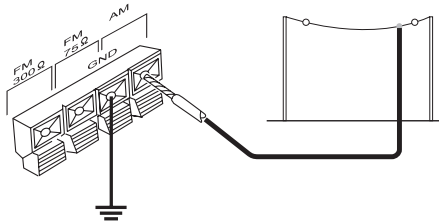

FM Antennas

Note: For the best results, use 75-ohm coaxial cable to connect an outdoor antenna to the receiver. Connect the supplied FM antenna to the **FM 300Ω ANTENNA** terminal as shown then extend it.

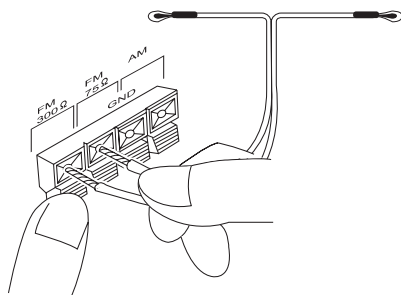

For better FM reception, you can also use a rabbit-ear TV antenna (for indoor use only) or an outdoor VHF TV antenna. To connect the TV antenna to the receiver, you need a VHF/UHF/FM splitter (not included). RadioShack stores carry a full line of quality antennas and antenna connection accessories.

Warning: To prevent injury, read and follow all cautions and warnings that accompany the outdoor antenna.

For the best radio reception, use an outdoor antenna. Follow these steps to connect an outdoor FM antenna to the receiver using 75Ω coaxial cable.

Note: If your antenna has 300Ω twin-lead cable, connect it to the **FM 300Ω ANTENNA** terminal.

1. Disconnect the supplied FM antenna from the receiver's **FM 300Ω ANTENNA** terminal.
2. With a stripping tool, remove about 1½ inches of the 75Ω cable's outer insulation to expose the cable's shielding.

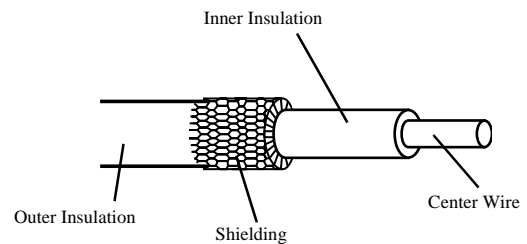

3. Fold back the shielding from the inner insulation.
4. Remove about 1 inch of the inner insulation from around the center wire.
5. Pull the shielding to one side. Connect the center wire to the receiver's **FM 75Ω ANTENNA** terminal. Twist the shielding to secure any loose wire strands, and connect it to the **GND ANTENNA** terminal.

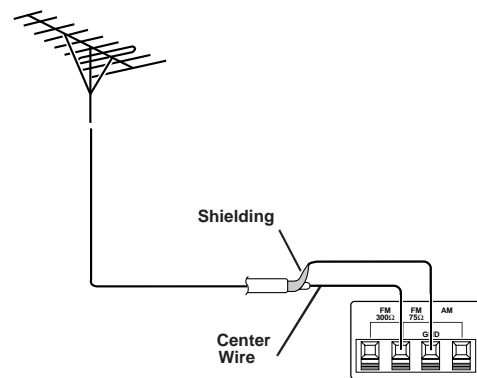

Caution: The cable's shielding should only touch the **GND ANTENNA** terminal.

Note: Grounding is not necessary for reception, but we recommend it for better FM reception and to avoid damage from lightning when you use an outdoor FM antenna. Use a separate piece of thick polyvinyl insulated wire to connect the **GND ANTENNA** terminal to an earth ground, such as a metal cold-water pipe.

Warning: Never connect a wire to a gas pipe for grounding since sparks might ignite the gas.

INSTALLING THE REMOTE CONTROL'S BATTERIES

Cautions:

- Use only fresh batteries of the required size and recommended type.
- Do not mix old and new batteries, different types of batteries (standard, alkaline, or rechargeable), or rechargeable batteries of different capacities.
- Dispose of old batteries promptly and properly. Do not burn or bury them.
- Always remove old or weak batteries. Batteries can leak chemicals that can damage electronic circuits.

Your remote control requires two AA batteries (not included) for power. For the best operation and longest life, we recommend alkaline batteries, available at your local RadioShack store.

1. To remove the battery compartment cover, push the compartment's tab in the direction of the arrow, then lift off the cover.

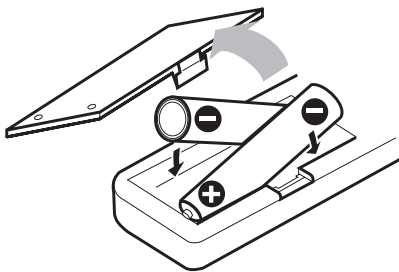

2. Place two fresh AA batteries in the compartment as indicated by the polarity symbols (+ and -) marked inside.
3. Replace the battery compartment cover.

Note: If the remote's range is reduced, replace the batteries.

CONNECTING TO AC POWER

Warning: To prevent electric shock, do not use this polarized plug with an extension cord, receptacle, or other outlet unless you can fully insert the blades to prevent blade exposure.

Before you plug in the receiver's power cord, double check all other connections.

To power the receiver, plug the supplied power cord into a standard AC outlet. The power cord's plug is polarized and fits only one way.

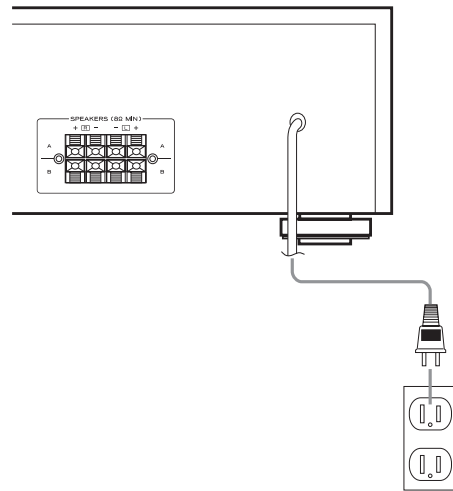

The **STAND BY** indicator lights when the receiver is plugged in but turned off.

Note: The receiver has a built-in circuit to protect it against overheating or short circuits. If your receiver automatically turns off (stand by mode), let it cool for several minutes. If the receiver overheated, it should play normally when you turn it back on. If there is a short circuit in your receiver, it will turn off again when you turn on the receiver. If this happens, check with your local RadioShack store for service.

OPERATION

Warning: To prevent possible hearing loss, turn **VOLUME** to **MIN** before you turn on the receiver or change the program source. After you turn on the receiver or change the program source, adjust **VOLUME** to a comfortable listening level.

You can use the supplied remote control by pointing it at the receiver's front panel and pressing the desired button(s). Many buttons on the remote control work the same as buttons on the receiver's front panel. Use these buttons exactly as you would use the corresponding buttons on the receiver.

Follow these steps to use the receiver.

1. Press **POWER** to turn on the receiver. It takes about 5 seconds to hear sound.
2. Select the speakers. An indicator lights next to the **A** and/or **B** to show which speakers are on.

If you connected speakers only to the **A** (or **B**) **SPEAKERS** terminals, press **SPEAKERS A** (or **B**) to turn on only those speakers. Do not press both **SPEAKERS A** and **B** because doing so turns off all speakers even though both indicators are on.

If you connected speakers to both the **A** and **B SPEAKERS** terminals, you can:

- Press **SPEAKERS A** or **B** to turn on either pair of speakers for a two-speaker effect.
- Press **SPEAKERS A** and **B** to turn on both pairs of speakers for a four-speaker effect.

Press **SPEAKERS A** and/or **B** to turn off all speakers so you can listen privately with headphones (see "Using Headphones" on Page 11).

3. Select a program source.

To tune to a radio station, see "Direct Tuning (Remote Control Only)" on Page 10.

To listen to signals from the component connected to the **TAPE MONITOR** jacks, press **TAPE MONITOR** so **TAPE MON** appears.

To listen to a source other than the one connected to the **TAPE MONITOR** jacks, press **TAPE MONITOR** so **TAPE MON** disappears. Then press **CD**, **PHONO**, or **AUX** (**CD**, **PHONO**, or **AUX** appears).

4. Turn **VOLUME** clockwise to increase the volume or counterclockwise to decrease it. Or, you can use **VOLUME** ▲ and ▼ on the remote control.
5. To adjust the tone, turn **BASS** and **TREBLE** toward + or -. To increase the high and low ranges of sound at low volume, press **LOUDNESS**. (To turn off this feature, press **LOUDNESS** again.)
6. To adjust the balance of sound between the left and right speakers, see "Adjusting Balance" on Page 11.

7. When you finish using the receiver, press **POWER** to turn it off.

USING THE SLEEP TIMER

The sleep timer lets you set the receiver to play for up to 90 minutes, then automatically turns off.

1. To set the timer, turn on the receiver then press **SLEEP** on the remote control. The display dims and shows **SLEEP 90 SLEEP**.
2. To set the sleep timer for less than 90 minutes, repeatedly press **SLEEP** to decrease the time by 10 minutes for each press of the button. Once you select the time, the receiver displays the program source. (**SLEEP** stays on the display in small letters until automatic shut-off.)
3. To briefly see the time remaining, press **SLEEP** once.

TUNING THE RADIO

Your receiver has four types of electronic tuning — manual, automatic, direct, and memory.

Note: For weak signals, we recommend manual tuning.

Manual and Automatic Tuning

Follow these steps to manually or automatically tune to the stations.

1. Press **FM** or **AM** on the front panel (or on the remote control) to select the desired band. The receiver tunes to and displays the frequency last selected in that band.
2. If **CH** appears on the right side of the display, press **MODE** to change the receiver to manual-tuning mode. **MANUAL** briefly appears.
3. To manually select the next higher or lower frequency, press **TUNING UP** or **DOWN** once. Or, hold down the button to rapidly scan through the frequencies; release the button to stop scanning.

To automatically search for the next higher or lower station, briefly hold down **TUNING UP** or **DOWN** to begin rapidly scanning through the frequencies. The receiver searches up or down the band, stopping on the next strong station.

Notes:

- **TUNED** appears when the received signal is strong.
- **STEREO** appears when the received FM broadcasts are in stereo.

- If you press **TUNING UP** at the top of the frequency range or **TUNING DOWN** at the bottom of the frequency range, the frequency at the opposite end of the range appears.

Direct Tuning (Remote Control Only)

Follow these steps to directly enter a frequency.

1. Press **FM** or **AM** on the front panel (or on the remote control) to select the desired band. The receiver tunes to and displays the frequency last selected in that band.
2. Press **DIRECT TUNING** on the remote control. **DIRECT IN** scrolls by, followed by **AM** ---- **kHz** for AM or **FM** -- - . -- **MHz** for FM. The first - flashes.
3. Enter the desired frequency using the remote control's number buttons.

Notes:

- If you press **1** to enter a FM frequency, such as 103.5, **10** automatically appears. If you also press the zero, the frequency that appears would be **100 . 30**.
- The last zero always appears automatically in both FM and AM frequencies.
- If you do not press a key within 5 seconds, the receiver exits direct tuning. Start over at Step 2.

MEMORY TUNING

Memory tuning lets you instantly tune to a stored frequency. You can store up to 30 AM and 30 FM frequencies in the receiver's memory. The receiver automatically stores the first 30 stations found in the selected band into the memory. You can also manually store a station into memory.

Automatically Storing Stations

1. Press **FM** or **AM** on the front panel (or on the remote control) to select the desired band. The receiver tunes to and displays the frequency last selected in that band.
2. Hold down **MEMORY** for more than 2 seconds. **MEMORY** and **CH** appear while the receiver steps through the frequencies, beginning with the low end (87.5 MHz for FM or 530 kHz for AM).
3. When the receiver finds a station, it stores in the first memory channel, the **CH** number increments, and the receiver looks for the next station. When the receiver finds the thirtieth station or when it reaches the high end of the frequency range, **MEMORY** disappears and the receiver tunes to the lowest frequency station in the band.

Repeat these steps to automatically store stations in the other band.

Manually Storing a Station

When the receiver automatically stores stations, some of them might not be your favorites. Or, the 30-channel memory might have filled up before the receiver reached your favorite station at the high end of the frequency range. Follow these steps to manually replace a station in memory.

1. Press **FM** or **AM** on the front panel (or on the remote control) to select the desired band. The receiver tunes to and displays the frequency last selected in that band.
2. If **CH** appears on the right side of the display, press **MODE** to change the receiver to manual-tuning mode. **MANUAL** briefly appears.
3. Use either automatic or manual tuning to find the desired station.
4. Press **MEMORY**. **MEMORY** flashes on the display.
5. While **MEMORY** flashes, press **TUNING UP** or **DOWN** until the desired memory channel number appears.
6. Press **MEMORY** again to store the station immediately. Or, wait about 5 seconds and the station is automatically stored in the selected channel.

Notes:

- If you store a frequency in a memory that already contains a frequency, you replace the previous frequency.
- If your receiver is disconnected from AC power for several days, it loses all the stored frequencies.

Tuning to a Station in Memory

1. Press **FM** or **AM** on the front panel (or on the remote control) to select the desired band. The receiver tunes to and displays the frequency last selected in that band.
2. If **CH** does not appear on the right side of the display, press **MODE** to change the receiver to memory-tuning mode. **PRESET** briefly appears.
3. Press **TUNING UP** or **DOWN** (or **PRESET CALL** ▲ and ▼ on the remote control) to tune to the next higher or lower station stored in memory.

Or, press **PRESET SCAN** to scan through the stations in memory. The receiver tunes to each station for about 5 seconds. When you hear the station you want to listen to, press **PRESET SCAN** again.

You can also tune to a station in memory by using the remote control's number buttons to enter the channel number. For single-digit channels, enter **0** first (for example, enter **06** for Channel 6).

Notes:

- To improve the reception of weak FM stations, press **FM MODE**. This reduces signal noise, but you hear monaural instead of stereo sound.
- For stations with a weak signal, we recommend manual tuning.

ADJUSTING BALANCE

The **BALANCE** control lets you adjust the sound balance between the left and right speakers. If you properly position the speakers and your listening area is centered between them, the center control setting is usually best (see “Positioning Speakers” on Page 5).

For an unusual speaker placement, press **AM** to select the AM band or select any source and play a monaural audio source. Turn **BALANCE** until you hear the sound coming equally from each speaker when you are in the listening area.

MUTING THE RECEIVER

To temporarily mute the sound, press **MUTING** on the remote control. The MUTE indicator on the receiver flashes. Press **MUTING** again to restore the audio level. The MUTE indicator turns off.

USING HEADPHONES

To listen with headphones (not supplied), insert the headphones' 1/4-inch plug into the receiver's front panel **PHONES** jack. To silence the speakers and listen with headphones without disturbing others, press **SPEAKERS A** and/or **B** so both indicators are off.

Listening Safely

To protect your hearing, note the following when using headphones.

- Set the volume to its lowest setting before you begin listening. After you begin listening, adjust the volume to a comfortable level.
- Do not listen at extremely high volume levels. Extended high-volume listening can lead to permanent hearing loss.
- Once you set the volume, do not increase it. Over time, your ears adapt to the volume level, so a volume level that does not cause discomfort might still damage your hearing.

CASSETTE DECK FEATURES

You can connect a cassette deck to the receiver. Selecting **TAPE MONITOR** lets you hear the playback from the cassette deck you connected to the receiver's **TAPE MONITOR** jacks.

Using the Tape Monitor Button

Press **TAPE MONITOR**. **TAPE MON** appears, along with the last program source you selected. You can hear the playback or monitor a recording from the cassette deck you connected to the receiver's **TAPE MONITOR** jacks.

The **TAPE MONITOR REC** jacks continue to output the previously selected sound source after you press **TAPE MONITOR**.

To return to the previous source, press **TAPE MONITOR** again so **TAPE MON** disappears.

Note: If you press **TAPE MONITOR** when that cassette deck is neither playing nor recording, the receiver mutes the current audio source. To hear the audio source, press **TAPE MONITOR** so **TAPE MON** disappears.

Recording a Program Source

The receiver sends the audio of the program source you select—**TAPE MONITOR**, **AUX**, **CD**, **FM/AM** (tuner), or **PHONO**—to the **TAPE MONITOR REC** jacks. The **VOLUME** control does not affect the level of the signal going to the tape decks.

When you record a program source using the cassette deck, you hear the program source's signal immediately after you record it onto the tape, if the cassette deck you connected has a three-head monitor function. (Be sure to read the owner's manual for your cassette deck.)

USING THE RESET BUTTON

If the receiver is subjected to a strong magnetic field or an electric shock, it might operate erratically. If this happens, turn off the receiver and press the rear panel **RESET** button with a straightened paperclip or other pointed object.

Caution: Pressing **RESET** clears everything stored in the receiver's memory.

TROUBLESHOOTING

If the receiver is not working as it should, the following suggestions might help. If you follow the suggestions in this chart and the receiver still does not work properly, contact your local RadioShack store for assistance.

Problem	Cause	Suggestion
Power does not turn on.	Power cord is disconnected.	Plug in the power cord.
No sound.	Incorrect connections.	Check and correct the connections.
	The mute function is activated.	Press MUTING .
	The volume is turned down.	Turn up the volume.
	Speaker wires are disconnected.	Connect the speaker wires.
	Neither set of speakers is selected.	Press SPEAKERS A or B .
	Both SPEAKERS A and B are selected when only one set of speakers is connected.	Press SPEAKERS A or B to turn off the speakers that are not connected.
	TAPE MONITOR is selected.	Press TAPE MONITOR so TAPE MON turns off.
Sound from only one speaker.	One of the speaker wires or the input cord is disconnected.	Check all connections.
	BALANCE is set too far to one side.	Set BALANCE to the center position.
High noise level.	Station not correctly tuned.	Adjust tuning.
	Antenna not connected.	Connect the antenna.
	FM antenna still coiled or is not pointing in the correct direction.	Stretch both ends of the antenna taut and reposition the antenna.
	AM loop antenna not pointing in the correct direction.	Adjust the AM loop antenna.
	Noise is coming from another electrical appliance.	Try using an AC line noise filter to reduce the noise.
Automatic tuning does not stop when searching for stations.	Stations are too weak.	Use a better antenna.
Remote control does not work.	Batteries are weak or missing.	Install fresh batteries.
	Poor angle or too great a distance from the remote sensor window.	Use the remote control within the effective range.
	There is an obstacle between you and the remote sensor window.	Change your position or remove the obstacle.
	A fluorescent light is shining on the remote sensor window.	Turn off the light.

CARE AND MAINTENANCE

To enjoy your RCA STA-3850 Stereo Receiver for a long time:

- Keep the receiver dry. If it gets wet, wipe it dry immediately.
- Use and store the receiver only in normal temperature environments.
- Handle the receiver gently and carefully. Don't drop it.
- Keep the receiver away from dust and dirt.
- Wipe the receiver with a damp cloth occasionally to keep it looking new.

Modifying or tampering with the receiver's internal components can cause a malfunction and invalidate its warranty.

This receiver has been manufactured to the specifications of RadioShack and is covered by a limited warranty from RadioShack. If your receiver is not operating as it should, take it to your local RadioShack store or call 1-800-THE-SHACK for assistance.

THE FCC WANTS YOU TO KNOW

Your receiver might cause radio or TV interference even when it is operating properly. To determine whether your receiver is causing the interference, turn off your receiver. If the interference goes away, your receiver is causing it. Try to eliminate the interference by:

- Moving your radio or TV away from the receiver
- Connecting your receiver to an outlet that is on a different electrical circuit from the radio or TV
- Contacting your local RadioShack store for help

If you cannot eliminate the interference, the FCC requires that you stop using your receiver.

SPECIFICATIONS

Amplifier

Power Output 50 Watts per Channel into 8 Ohms
From 40 to 20,000 Hz,
With No More than 0.5% Total Harmonic Distortion
Measured Pursuant to the Federal Trade Commission's
Trade Regulation Rule on Amplifier Output Power Claims

Input Sensitivity/Impedance

Phono 2.5 mV/47 kohms
CD, AUX, TAPE MONITOR 200 mV/47 kohms

Signal-to-Noise Ratio (IHF, Short-Circuited, A Network)

Phono 72 dB
CD, AUX, TAPE MONITOR 95 dB

FM Tuner

Frequency Range 87.5 to 108 MHz

Usable Sensitivity Mono: 15 μ V/m, EMF

Signal-to-Noise Ratio

Mono 68 dB
Stereo 63 dB

Distortion Stereo: 0.5% (1 kHz)

Alternate Channel Selectivity 45 dB (400 kHz)

Stereo Separation 35 dB (1 kHz)

AM Tuner

Frequency Range 530 to 1720 kHz

Sensitivity (IHF, Loop Antenna) 500 μ V/m

Selectivity 25 dB

Signal-to-Noise Ratio 35 dB

General

Power Requirements 120 Volts AC, 60 Hz

Power Consumption 120 Watts

Dimensions (HWD) $5\frac{1}{8} \times 16\frac{9}{16} \times 12\frac{1}{4}$ Inches
(130 \times 420 \times 310 mm)

Weight 14 lb (6.3 kg)

Specifications are typical; individual units might vary. Specifications are subject to change and improvement without notice.

NOTES

Limited Two-Year Warranty

This product is warranted by RadioShack against manufacturing defects in material and workmanship under normal use for two (2) years from the date of purchase from RadioShack company-owned stores and authorized RadioShack franchisees and dealers. EXCEPT AS PROVIDED HEREIN, RadioShack MAKES NO EXPRESS WARRANTIES AND ANY IMPLIED WARRANTIES, INCLUDING THOSE OF MERCHANTABILITY AND FITNESS FOR A PARTICULAR PURPOSE, ARE LIMITED IN DURATION TO THE DURATION OF THE WRITTEN LIMITED WARRANTIES CONTAINED HEREIN. EXCEPT AS PROVIDED HEREIN, RadioShack SHALL HAVE NO LIABILITY OR RESPONSIBILITY TO CUSTOMER OR ANY OTHER PERSON OR ENTITY WITH RESPECT TO ANY LIABILITY, LOSS OR DAMAGE CAUSED DIRECTLY OR INDIRECTLY BY USE OR PERFORMANCE OF THE PRODUCT OR ARISING OUT OF ANY BREACH OF THIS WARRANTY, INCLUDING, BUT NOT LIMITED TO, ANY DAMAGES RESULTING FROM INCONVENIENCE, LOSS OF TIME, DATA, PROPERTY, REVENUE, OR PROFIT OR ANY INDIRECT, SPECIAL, INCIDENTAL, OR CONSEQUENTIAL DAMAGES, EVEN IF RadioShack HAS BEEN ADVISED OF THE POSSIBILITY OF SUCH DAMAGES.

Some states do not allow the limitations on how long an implied warranty lasts or the exclusion of incidental or consequential damages, so the above limitations or exclusions may not apply to you.

In the event of a product defect during the warranty period, take the product and the RadioShack sales receipt as proof of purchase date to any RadioShack store. RadioShack will, at its option, unless otherwise provided by law: (a) correct the defect by product repair without charge for parts and labor; (b) replace the product with one of the same or similar design; or (c) refund the purchase price. All replaced parts and products, and products on which a refund is made, become the property of RadioShack. New or reconditioned parts and products may be used in the performance of warranty service. Repaired or replaced parts and products are warranted for the remainder of the original warranty period. You will be charged for repair or replacement of the product made after the expiration of the warranty period.

This warranty does not cover: (a) damage or failure caused by or attributable to acts of God, abuse, accident, misuse, improper or abnormal usage, failure to follow instructions, improper installation or maintenance, alteration, lightning or other incidence of excess voltage or current; (b) any repairs other than those provided by a RadioShack Authorized Service Facility; (c) consumables such as fuses or batteries; (d) cosmetic damage; (e) transportation, shipping or insurance costs; or (f) costs of product removal, installation, set-up service adjustment or reinstallation.

This warranty gives you specific legal rights, and you may also have other rights which vary from state to state.

RadioShack Customer Relations, 200 Taylor Street, 6th Floor, Fort Worth, TX 76102

We Service What We Sell

04/99

RadioShack
A Division of Tandy Corporation
Fort Worth, Texas 76102

Free Manuals Download Website

<http://myh66.com>

<http://usermanuals.us>

<http://www.somanuals.com>

<http://www.4manuals.cc>

<http://www.manual-lib.com>

<http://www.404manual.com>

<http://www.luxmanual.com>

<http://aubethermostatmanual.com>

Golf course search by state

<http://golfingnear.com>

Email search by domain

<http://emailbydomain.com>

Auto manuals search

<http://auto.somanuals.com>

TV manuals search

<http://tv.somanuals.com>