

3-Band FM Scanning Monitor Receiver

VHF: 30-50/148-174 MHz UHF: 450-512 MHz



PRO-16A

OWNER'S MANUAL

PLEASE READ BEFORE
USING THIS EQUIPMENT

REALISTIC®

**CAT. NO.
20-165**

CUSTOM MANUFACTURED FOR RADIO SHACK  A DIVISION OF TANDY CORPORATION

Your PATROLMAN PRO-16A scanning receiver is a completely transistorized VHF/UHF superheterodyne receiver using dual-conversion for the VHF bands and triple conversion for the UHF band. It is capable of automatically scanning sixteen crystal-controlled channels. Some special features are: four ceramic filters, channel lock-out circuit, skipper circuit, AFC circuit for UHF band, scan delay circuit (switchable) and AC or DC operation.

It is designed for use in the narrow-band FM channels of public service communications: VHF and UHF band police, fire, civil defense, radio telephone, forestry and weather service, plus many other industrial radio services and the 2-meter "HAM" radio band (upper end). These and many other services share this band of frequencies from 30 to 50 MHz, 148 to 174 MHz and 450 to 512 MHz.

The PRO-16A features both high sensitivity and selectivity and a sophisticated circuit which includes 10.7 MHz and 445 kHz ceramic filters to reduce or eliminate adjacent-channel or strong-signal interference. Such interference is often experienced when operating in urban and metropolitan areas or where very strong and closely placed signals are present.

An important engineering achievement, designed for practical applications, the PRO-16A is remarkably easy to use, yet its up-to-date, complex circuit consists of 52 separate transistors (three of which are Field Effect Transistors), six integrated circuits (which incorporate the equivalent of hundreds of components), 66 diodes and 1 zener diode.

This Receiver is designed to operate from either 120 volts AC or 12 volts DC **Negative Ground**. If it fails to operate, and there is no clear reason for the failure, first check the "power" switch (part of **Volume** control). Also, before connecting the PRO-16A receiver to a DC power supply, check the voltage polarity. Attempting to operate the negative-ground PRO-16A from one of the rare positive-ground automotive or boat electrical systems, or from a wrongly connected battery, will at least blow a fuse. It may do further damage, so that expensive and time-consuming repairs are necessary before the PRO-16A can be used again. The Radio Shack warranty does not apply to any damage caused by this, inadequate lightning protection, or other improper connections.

WARNING: TO PREVENT FIRE OR SHOCK HAZARD, DO NOT EXPOSE THIS RECEIVER TO RAIN OR MOISTURE.

SPECIFICATIONS

| | |
|------------------------------------|--|
| SEMICONDUCTOR COMPLEMENT: | 52 transistors, 6 integrated circuits and 67 diodes |
| FREQUENCY RANGE: | 30-50 MHz/148-174 MHz and 450-512 MHz |
| CHANNELS OF OPERATION: | Sixteen—as determined by any one of 16 crystals operating in the frequency range |
| FREQUENCY COVERAGE (VHF): | 6 or 8 MHz for maximum sensitivity (40 MHz \pm 3 MHz) (153 MHz \pm 4 MHz) |
| (UHF): | 30 MHz for maximum sensitivity (480 MHz \pm 15 MHz) |
| SENSITIVITY: | Better than 1 μ V for 20 dB quieting |
| SELECTIVITY: | \pm 13.5 kHz, -6 dB \pm 25 kHz, -50 dB |
| ADJACENT CHANNEL REJECTION: | 65 dB (25 kHz) |
| SPURIOUS REJECTION (VHF): | Greater than 50 dB |
| IMAGE REJECTION (VHF): | Greater than 35 dB |
| (UHF): | Greater than 20 dB |
| VARIABLE SCANNING SPEED: | 10 to 20 channels/second |
| PRIORITY CYCLE RATE: | 0.8 to 1.5 seconds |
| DELAY TIME: | 1.5 to 3 seconds |
| MODULATION ACCEPTANCE: | \pm 7 kHz |
| AFC ACTION (UHF): | Greater than \pm 4 kHz |
| I.F. FREQUENCY: | 44 MHz (UHF Band only) 10.7 MHz and 455 kHz |
| FILTER: | Ceramic filter (10.7 MHz and 455 kHz) |
| SQUELCH SENSITIVITY: | Variable from less than 1 microvolt |
| AUDIO POWER: | 2 watts maximum |
| CRYSTAL REQUIREMENTS: | Standard HC-25/U, 3rd overtone |
| BUILT-IN SPEAKER: | 2½" x 4" (6.3 x 10 cm) oval speaker |
| POWER REQUIREMENTS: | AC—120 volts, 60 Hz, 12 watts, max. DC—12-15 volts Negative Ground only (10 watts maximum) |

PREPARING FOR USE

To use your PRO-16A, you must do three things:

- Connect power
- Install from 1 to 16 crystals
- Connect an antenna

To make a quick check, you can just connect the Line Cord to a source of 120 volts, 60 Hz, AC power. If you intend to use a 12 volt source, you must connect the 12 volt DC power plug wires as noted later on under "Mobile Installation". With an antenna connected and a crystal installed, turn the Receiver on by rotating **VOLUME** clockwise. Rotate **SQUELCH** maximum counterclockwise. You should hear a "rushing" sound in the speaker.

Crystals are not included with your PRO-16A because the frequencies are so numerous. The frequencies used in your part of the country will be different from those used in other areas. Order the crystals you want from your Radio Shack store—specify the model number of this unit and the frequency you want to receive.

Remove the two Screws from the Crystal Compartment Cover (bottom of cabinet) to expose the crystal sockets and program switches. Provision is made to install 16 crystals; the program switch position can be used to obtain either VHF(L), VHF(H) or UHF.

For UHF crystals, position the program switch to UHF (Marked "U" on printed circuit board).

For VHF(H), set the program switch to VHF (Marked "H" on printed circuit board).

For VHF(L), set the program switch to VHF (Marked "L" on printed circuit board).

In the example shown channel 1 will have a VHF(H) crystal and channel 9 will have a UHF crystal.

NOTE: If you have a channel that you are particularly interested in, put the crystal for that channel into Channel 1 position (PRIORITY). Refer to OPERATION section for details on the function of PRIORITY.

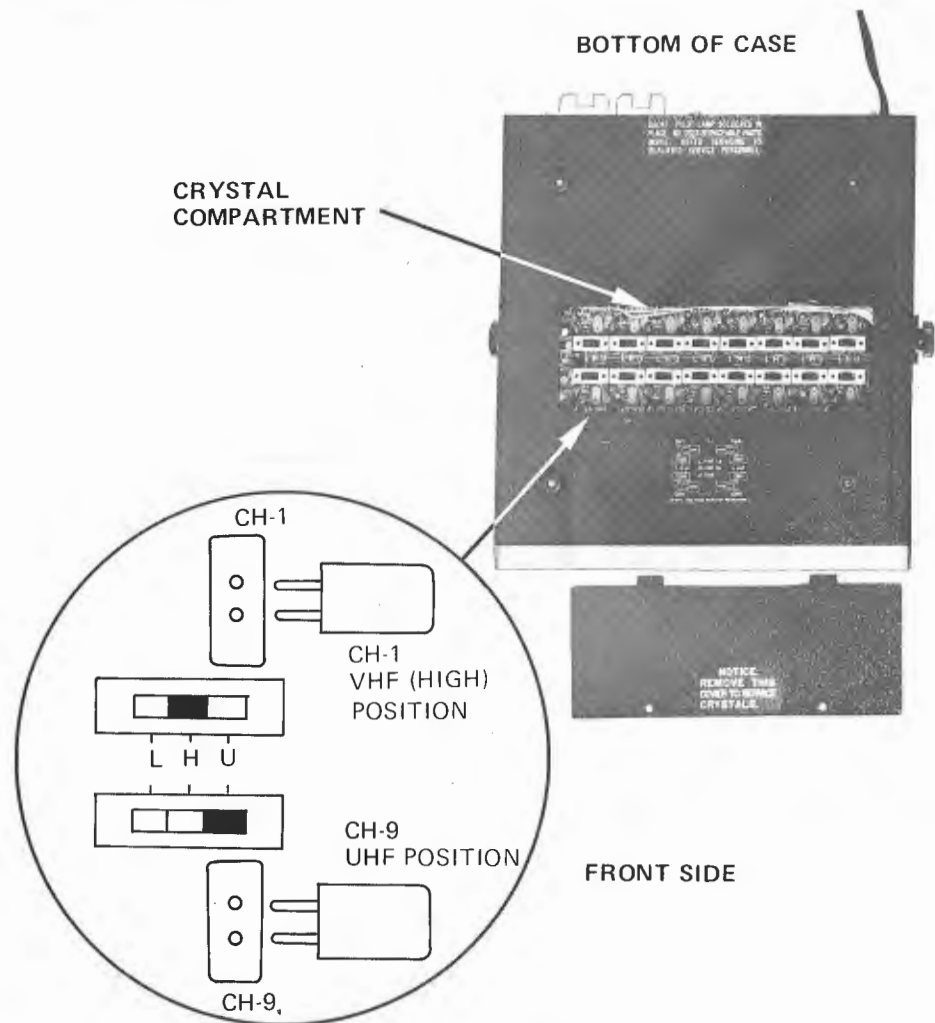

Ask the manager of your Radio Shack store what the most popular and active channels are in your area. He will be glad to advise you.

Since crystal frequencies must be extremely accurate and crystals should be matched for specific units, we recommend you obtain crystals for your Receiver **only** from Radio Shack. We can not be responsible for the poor or improper operation of crystals from another manufacturer(s).

CONTROL LOCATION AND FUNCTION

OFF-VOLUME is the power switch and Volume control. When not in use, rotate this control to the left to turn it off.

SQUELCH control is to eliminate annoying background noise between signal transmissions. When properly set, Squelch will keep the PRO-16A silent until a signal comes in on the channel(s) you are listening to—then, the Squelch circuit will “open” and you hear the signal.

MANUAL SELECTOR Button—when the **SCAN/MANUAL** button is in the **MANUAL** position (out), use this button to advance the Receiver to the next channel in sequence. Each time you press this button, the Receiver will advance just one channel.

SCAN/MANUAL Button is for determining the function of the scanning feature. In the **SCAN** (in) position, each channel will be scanned automatically. In the **MANUAL** (out) position, the PRO-16A will not scan, but will remain tuned to the channel indicated by a Lighted Channel Indicator.

SCAN RATE Control—adjust for the desired rate of automatic scanning. In the **SLOW** position, you’ll be scanning the channels at about 10 per second; **FAST** will give you a rate of about 20 per second. Use the setting that results in a minimum of missed calls (practice and experience will help you find the best setting).

DELAY Button—when you press this button in, you activate a circuit which holds the scanner on channel for about 2 seconds after the carrier has gone off the air, before the scanning function once again takes over. To defeat this Delay feature, press again to release the button.

Channel Lock-out Button/Channel Indicator Lights (PROGRAM)—in the “in” position (button pressed in), that channel is active. When you press the button again (to pop it “out”), that channel is automatically “lock out” and will not function.

The buttons light up to show which channel(s) is active. During scanning, these lights light up in sequence; when the receiver is operative on one of the channels, the light for that channel will go on. When the Channel Lock-out Button for that channel is out, that Light will not light.

PRIORITY Button—will lock in channel 1 for priority reception over any other active channel. Thus, when pressed in, if a signal comes on this channel, the Receiver will automatically lock-in on it and will stop scanning. When the signal ceases on this channel, the receiver will start scanning once again.

VHF Antenna Jack—for VHF reception, connect an antenna to this jack. Use an antenna such as Catalog Number 20-161 (indoor operation).

UHF Antenna Jack—connect an external antenna to this jack for UHF reception. Use an antenna such as Radio Shack Catalog Number 20-451 (indoor operation).

TAPE OUT Jack—for recording “off-the-air”, you can connect your tape recorder directly to this jack.

Headphone/External Speaker jack is for plugging in a headphone or an external speaker. Use it for private listening, or in areas where background noise is excessive (in factories, at the scene of an accident or fire, in a vehicle, etc.). If you want a remote speaker, plug it in here. Connecting a plug to this jack automatically disconnects the internal speaker.

Mounting Bracket—this universal type bracket is provided for quick and easy installation in a vehicle, boat or for permanent installation in a base station situation.

Line Cord—for AC operation, plug into a source of 120 volts, 60 Hz, AC power.

Crystal/Program Switch Compartment—remove screws to open the case bottom to install or replace crystals.

DC Power jack is for connecting an external source of 12 volts DC, negative ground. This will permit you to use the PRO-16A in a vehicle or boat.

VOLUME/
Power
Control

SQUELCH
Control

SCAN
RATE
Control

PRIORITY

CHANNEL LOCK-OUT BUTTONS
(INDICATOR LIGHTS)

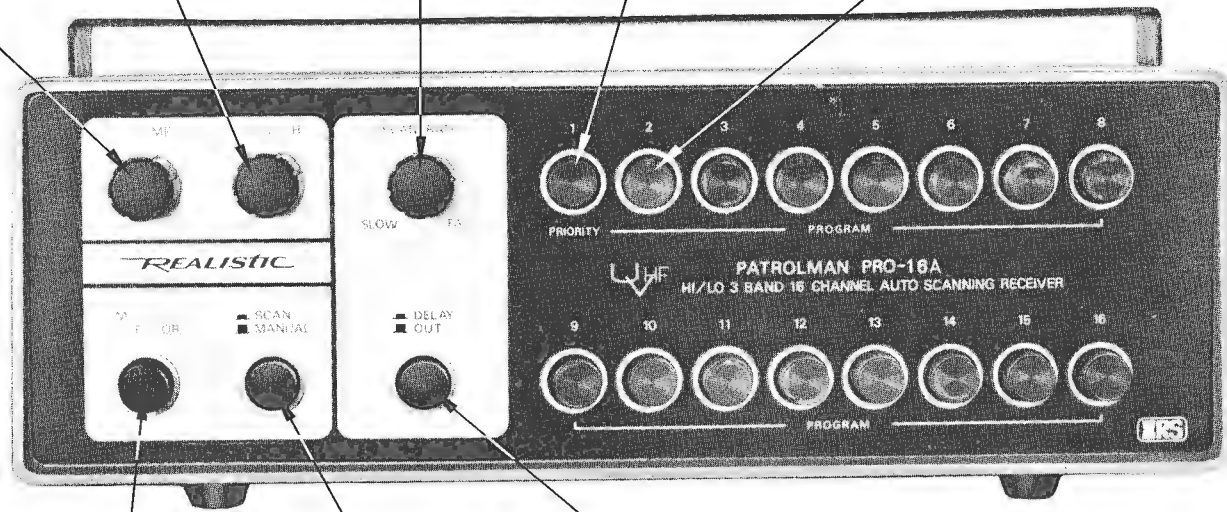

MANUAL
SELECTOR
Button

SCAN/MANUAL
Button

DELAY (ON-OFF)
Button

VHF
ANT JACK

UHF
ANT JACK

TAPE OUT
JACK

HEADPHONE/
EXT. SPEAKER
JACK

DC POWER
JACK

AC LINE
CORD

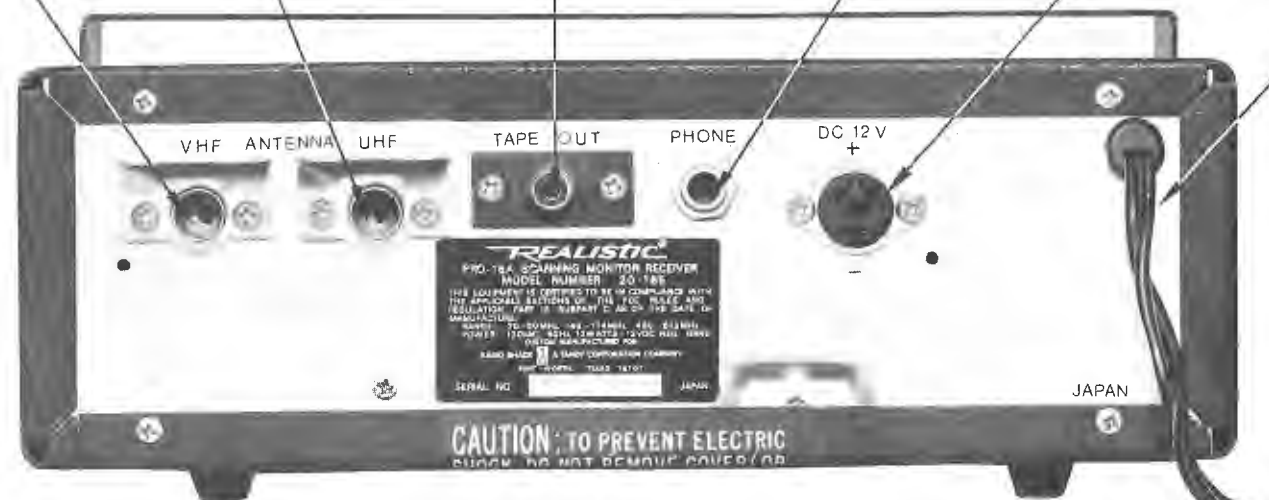

INSTALLATION

A good installation will make the most of the PRO-16A's capabilities. Don't lose any of the tiny signals by using an inadequate antenna or poor quality lead in. Use an antenna of correct length and a good quality foam coaxial cable. The antennas that you choose, and how you install them, will have a great effect on how well your receiver will work. Your PRO-16A is designed to utilize two antennas, one for VHF and one for UHF.

BASE INSTALLATION

For a base installation, you only need two things. The most important is a good antenna. For superior reception, it is vital that you use the best antenna you can afford and then mount it properly. We recommend a Radio Shack Catalog Number 20-182 for superior UHF reception and a 20-015 for VHF reception. Use RG 58/U coaxial lead-in cable to assure maximum transfer of the tiny signals. Use Motorola adapter plugs as appropriate (278-208).

The only other thing you need to do is connect the line cord to a source of 120 volts, 60 Hz, AC power.

Base Antennas

Although there are only a few basic types of antennas, there are many models of base Monitor antennas. Some of the most popular antennas combine several frequencies.

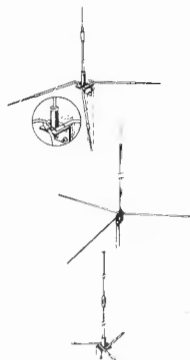

Since your Receiver tunes in both high and low VHF we suggest an antenna such as our Hi-Low VHF Ground Plane 20-015.

Or, you could use our Hi-VHF/UHF Ground Plane 20-176.

For UHF, we recommend 20-182, our UHF Ground plane antenna.

MOBILE INSTALLATION

Safety and operating convenience are the primary factors to consider when you install any equipment in a vehicle. Be sure you can easily reach the Receiver's controls. Also, be sure the connecting cables do not interfere with the operation of the vehicle (brake, accelerator, etc.).

You can mount the Receiver to the underside of the dash or instrument panel in the vehicle or boat. Use the universal mounting bracket provided. Take care when drilling holes that you do not drill into existing wires or trim.

The PRO-16A is designed to operate from a **negative ground** 12 volt DC source. Be sure you connect power leads with the correct polarity. Use the DC Power cable provided. The other end of these wires can be connected to an Auto Cigarette Lighter Plug, Catalog Number 274-331; or you can make the connections directly to the fuse block of the vehicle or boat. Be sure to observe correct voltage polarity: + to + and - to -.

IMPORTANT: If your car has been burning out headlamps and other bulbs at a rapid rate, have the voltage regulator checked for proper output: excessive voltage (more than 16 volts) can cause serious damage to your receiver.

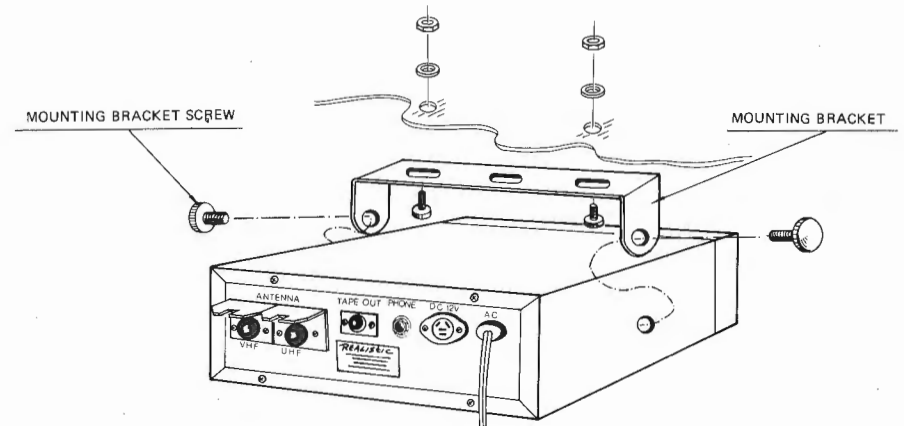

Mobile Antennas

There are many possible mounting locations on a car. Three of the most popular locations for monitor antennas are shown below.

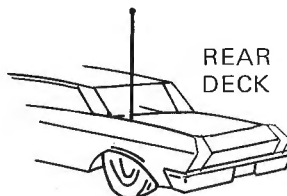
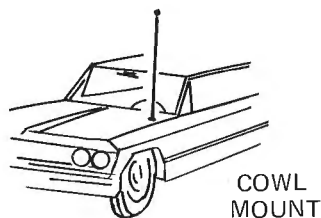
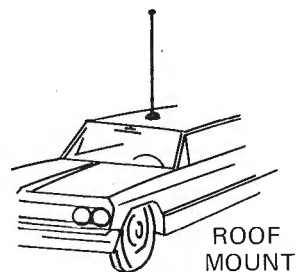

ROOF MOUNT—The antenna is mounted in the center of the roof. This position is considered the best by many, because it generally results in better reception than the other locations. Radio Shack's Hi-VHF/UHF Mobile Mount (Catalog Number) 20-177 comes complete, like all our monitor antennas, with low-loss coax cable.

COWL MOUNT—If you would rather not cut a hole in the center of your vehicle's roof, you may prefer this location. Ask about our 20-016 Cowl Mount antenna which is especially designed for Hi-Low VHF monitoring. For UHF, use 20-183.

REAR DECK—Installation in this location, may result in less noise because it is further from the engine. Your Radio Shack salesman will help you select the antenna which is best for you.

Keep the following points in mind when installing your mobile antenna.

1. Mount the antenna as high as possible.
2. Mount it rigidly, so it will remain vertical while in motion.
3. Mount as far as possible from the engine compartment.

MOBILE NOISE SUPPRESSION

This receiver is very sensitive, and will pick up signals that are extremely weak. With this extreme sensitivity, you will find that the receiver will amplify weak signals, along with any noise that may be present.

When operating a receiver in a vehicle, you will find that the vehicle generates noise, and this noise can become very objectionable. Mobile operation will not be as quiet as base station operation, but steps can be taken that will greatly improve the noise situation.

ELECTRICAL SYSTEM:

Generally speaking, noise can be generated by any device or connection that carries electrical current. Any device that generates a spark should also be suspected. Bypass any suspected wire to ground with a high quality 1 μ F coaxial capacitor.

A very common source of noise is the generator or alternator. This type of noise will sound like a musical whine, and will also vary with speed of the engine. Generator and alternator noise can usually be reduced by connecting a coaxial-type capacitor from the armature terminal to the metal case.

IGNITION SYSTEM:

The ignition system is the most common source of noise. This noise can be identified by the fact that its speed varies with the engine speed. Ignition noise will sound like a series of "popping" sounds, while the engine is idling, and will speed up to a buzzing sound as engine speed is increased.

There are a number of things that can be done for this type of noise.

1. Use radio suppression-type ignition wire and resistor spark plugs.
2. Check high-voltage wiring for leakage, cracks, etc. Replace any old wiring.
3. In extreme cases, obtain an ignition noise suppression kit—it should shield all ignition wiring. This will provide maximum noise suppression.

OPERATION

After power and antennas are connected and a crystal (or crystals) has been installed, your PRO-16A is ready to use.

Turn **VOLUME** "on", by rotating to the right. Rotate **SQUELCH** fully counterclockwise. Set all the Channel Lock-out Buttons "on" (press in). You should hear a rushing sound from the speaker. Now adjust **SQUELCH** clockwise until you no longer hear the rushing background noise (further explanation of **SQUELCH** adjustment is noted below).

If you want the PRO-16A to continuously scan the channels for which you have crystals installed, you must adjust **SQUELCH** as instructed above, then press **SCAN/MANUAL** button in, to the **SCAN** position. The PRO-16A will constantly scan each channel in sequence; when a signal appears on one of the channels, the receiver will lock onto that channel and you will hear the signal.

If you do not want automatic scanning on one or more channels, press their Channel Lock-out Buttons "off" (press in to release the button so it pops out).

If you want to stay tuned to one channel only, press **SCAN/MANUAL** button again to make it pop out to the **MANUAL** position. The Receiver will stop automatic scanning; now press **MANUAL SELECTOR** button to advance to the channel you want to listen to (as indicated by the Light). For **MANUAL** scanning, the receiver can be either "squelched" or "unsquelched", for Automatic scanning, **SQUELCH** must be set to eliminate the background noise.

To eliminate the annoying background noise, rotate **SQUELCH** clockwise until the background noise just stops. You can't adjust **SQUELCH** properly while listening to a station, so wait till signals cease. If you set **SQUELCH** as noted above, the PRO-16A will appear "dead" until a signal comes in; when a signal comes in, the Squelch circuit "opens up" and you hear the signal. When the signal ceases, the Squelch circuit "closes" and cuts out all sound until the next signal comes in.

PRIORITY:

In most areas there is usually one channel you will want to monitor consistently. The Priority function allows you to do this and yet you can still scan all the other channels.

When the **PRIORITY** Button is pressed in, the scanner will operate as usual—scanning across channels 1 thru 16 looking for an active channel. However, if it should stop on any channel other than the priority channel for more than two seconds, the Receiver will automatically scan back and check the priority channel.

This priority channel sampling occurs almost instantaneously and if the priority channel is not active, the scanner returns to the channel being monitored previously. This scan-back takes only six-hundredths of a second, so there is scarcely any interruption to the signal you were monitoring.

If the priority channel is active, the scanner will continue to monitor it until it clears, and then return to the channel previously being monitored.

SCAN RATE (Scan Speed):

You can vary the scanning rate from about 10 to 20 channels per second by adjusting **SCAN RATE**. Use the setting that seems best for your needs. It is particularly useful when using **PRIORITY**—you can get rapid scanning, plus fast scan-back checking of the Priority channel.

SCAN DELAY:

The PRO-16A has a built-in 2 second delay feature which virtually eliminates missed replies. This circuit holds the Receiver on the channel you are monitoring for a period of 2 seconds after the carrier has gone off the air, before it resumes normal scanning function. This

Delay circuit is switchable—press DELAY in to activate the Delay function; leave out to remove this delay. The Priority channel has a separate built-in Delay circuit which is not switchable—so when PRIORITY is activated, you know for sure you won't miss any replies on that channel.

SKIPPER CIRCUIT:

Your scanner has a built-in skipper circuit which is fully automatic and can not be disabled. It works in both the SCAN and MANUAL modes of operation. This feature causes the unit to skip over a locked out channel(s) so that there is no possibility of the Receiver stopping on a locked out channel(s).

ACCESSORIES

Your PRO-16A can be powered either from 120 volts AC or from any source of 12 volts DC, negative ground. Radio Shack sells a special portable power pack with 8 D cell batteries, battery holder and adapter plug for a cigarette lighter socket. It's a handy accessory for portable or vehicle operation. For more permanent 12 volt installations, attach the DC power cable to the connector on the back. Then, attach other end of the wires to a + and - source of 12 volts (e.g. at the fuse block on a vehicle). Be sure to observe correct polarity.

A pair of headphones can be a very useful accessory. In areas where a high noise level is present (in a factory, at the scene of a fire or accident, etc.), or when you want to listen privately, use headphones. Your Radio Shack store has a couple of very fine selections for your PRO-16A. Just plug them into the rear panel Speaker/Headphone jack.

If you want to listen to the Receiver from a remote position, or just want to use an external speaker, connect it to the Speaker/Headphone jack. Again, your Radio Shack store has some speakers specifically made for this purpose.

You can record off-the-air using a tape recorder connected to the TAPE OUT jack on the rear.

FREQUENCY COVERAGE

For maximum sensitivity, the channel frequencies you choose should be within 3 MHz of 40 MHz on the VHF band (that is, in the spread of 37 to 43 MHz), 4 MHz of 153 MHz on the VHF band (from 149 to 157 MHz). For the UHF band, stay within 15 MHz of 480 MHz (from 465 to 495 MHz). The PRO-16A will function very adequately down to 30 and up to 50 MHz. from 148 to 174, and from 450 to 512 MHz, but with reduced sensitivity. The superior reception spread of 6, 8 or 30 MHz (± 3 , 4 or 15 MHz) can be moved up or down in this band of frequencies by special realignment of the front end circuitry of the PRO-16A (which should be attempted only by qualified Electronics Service Technicians who have adequately calibrated, precision test equipment).

TYPES OF SIGNALS YOU'LL BE ABLE TO MONITOR

Your community is alive with action—action which is constantly being reported on the air waves. And your PRO-16A will automatically scan the air waves to bring you that action—your police force at work, a fire truck on a mission, Sheriff's department, State police, the National Weather Service, Ham Radio operators, highway and other emergency-type services, some industrial services, some transportation services (taxi, trucks, railroad), plus some Government services. Lots of things are going on that most of us just are never aware of. But, with the right frequency crystal in your PRO-16A, you can monitor such exciting signals. You'll have to do a little investigating in your community to find out what services are active and on what frequencies. You will find one of our books to be very interesting and helpful in this area: REALISTIC GUIDE TO POLICE, FIRE AND AIRCRAFT RADIO.

What to listen for and where? That is a little difficult for a specific answer. Each area of the country can and will use different channels. All we can do is give you some general pointers and then let you take it from there.

Find out if there is a local club which monitors these frequencies. Often a local electronics repair shop that does work on the equipment can give you the channel frequencies used by local radio services. A volunteer police or fire employee can also be a good source of this information.

An interesting service is the Mobile Telephone. FCC has assigned this service channels in the range of 152.51 to 152.81 MHz at every 0.030 MHz (channels are 30 kHz apart). Also, 454.375 to 454.95 MHz, with channels 25 kHz apart from 454.375 to 454.625 and then every 50 kHz up to 454.95.

As a general rule on VHF, most activity will be concentrated between 153.785 and 155.98 and then again from 158.73 to 159.46 MHz. Here you'll find local government, police, fire and most such emergency services. If you are near a railroad yard or major railroad tracks, look around 160.0 to 161.9 for them.

In some of the larger cities, there has been a move to the UHF bands for these emergency services. Here, most of the activity is in a spread of 453.05 - 453.95 and again at 456.025 - 459.95 MHz.

In the UHF band, the overall spread of 456.025 - 459.95 and again at 465.025 - 469.975 MHz is used by mobile units and control stations associated with base and repeater units which operate 5 MHz lower (that is, 451.05 - 454.95 and 460.025 - 464.975 MHz). This means that if you find an active channel inside one of these spreads, you can look 5 MHz lower (or higher as the case may be) to find the major base station/repeater for that radio service.

NATIONAL WEATHER SERVICE RECEPTION

Continuous weather broadcasts are transmitted 24-hour-a-day in many parts of the country. If you are using a crystal set to one of the two channels assigned (162.55 or 162.40 MHz), your PRO-16A will automatically lock-in on that channel, since the broadcasts are continuous. To prevent automatic locking, set the channel lock-out button for that channel to the "off" position (button out). When you want a weather report, set the Lock-Out Button to the "on" position (press in) for that channel. In areas where two stations are close to each other, one will use 162.55 and the other will use 162.40 MHz. Check with your local FCC office or the Weather Bureau for the frequency used in your area.

MAINTENANCE

The PRO-16A is a ruggedly built electronic unit, with all parts conservatively rated. However, you should treat it with care; don't subject it to excessively rough handling. You will find it will give you long life if kept free from dirt and excessive humidity.

BLOCK DIAGRAM

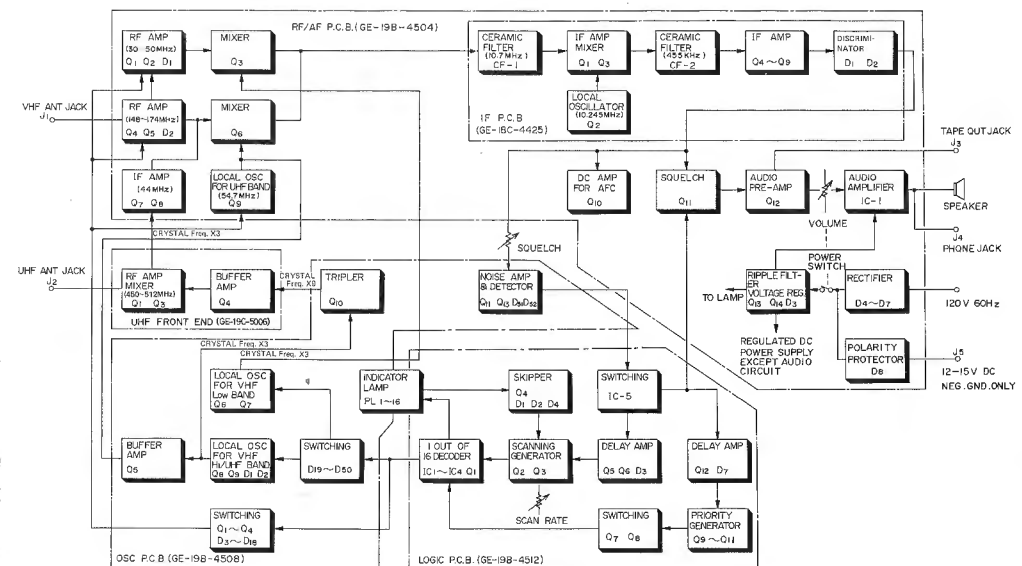

SCHEMATIC DIAGRAM

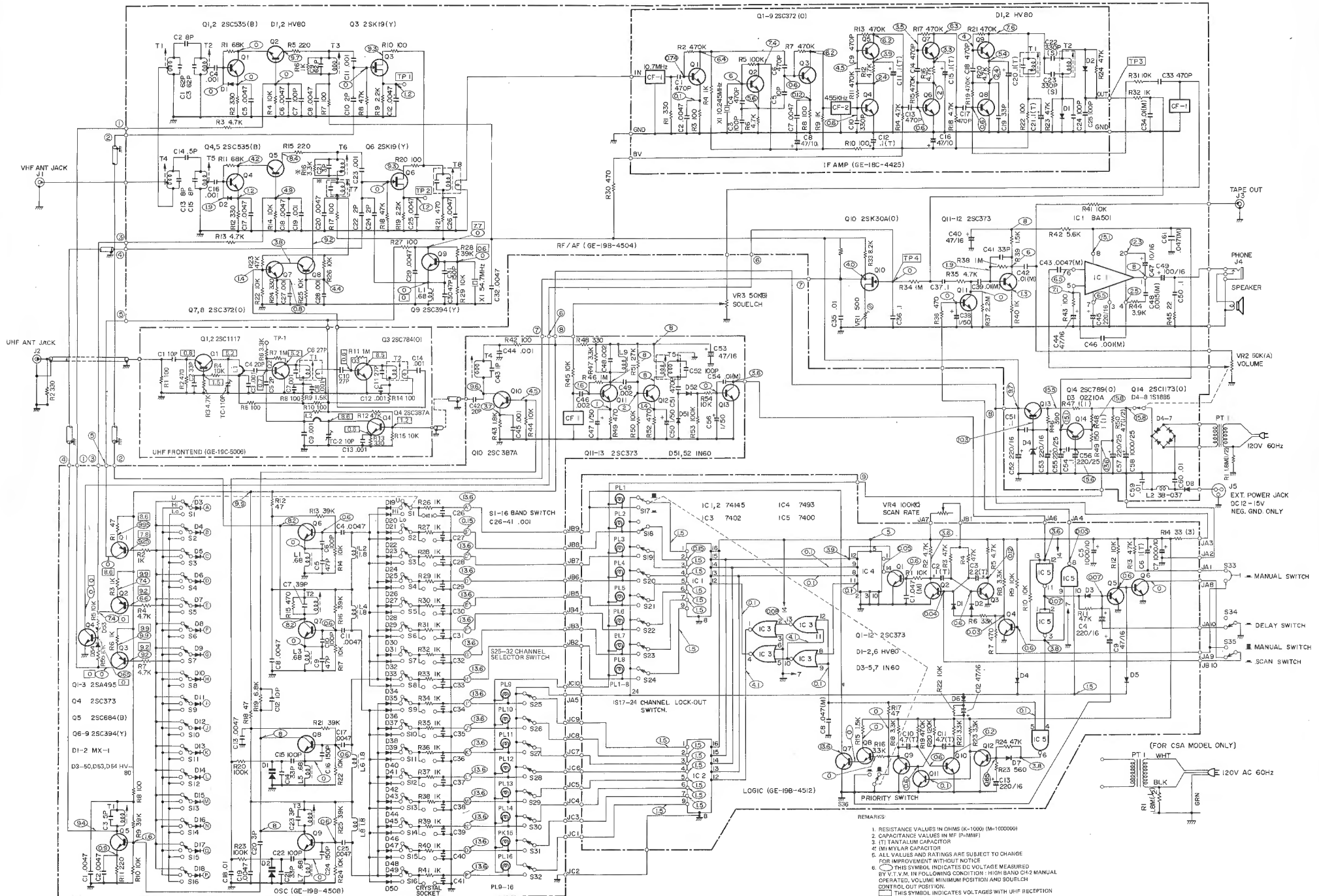

RADIO SHACK LIMITED WARRANTY

This equipment is warranted against defects for 1 year from date of purchase. Within this period, we will repair it without charge for parts and labor. Simply **bring your sales slip** as proof of purchase date to any Radio Shack store. Warranty does not cover transportation costs. Nor does it cover equipment subjected to misuse or accidental damage.

This Warranty gives you specific legal rights and you may also have other rights which vary from state to state.

We Service What We Sell

RADIO SHACK  A DIVISION OF TANDY CORPORATION

U.S.A.: FORT WORTH, TEXAS 76102

CANADA: BARRIE, ONTARIO, CANADA L4M 4W5

TANDY CORPORATION

AUSTRALIA

280-316 VICTORIA ROAD
RYDALMERE, N.S.W. 2116

BELGIUM

PARC INDUSTRIEL DE NANINNE
5140 NANINNE

U. K.

BILSTON ROAD
WEDNESBURY, STAFFS WS10 7JN

Free Manuals Download Website

<http://myh66.com>

<http://usermanuals.us>

<http://www.somanuals.com>

<http://www.4manuals.cc>

<http://www.manual-lib.com>

<http://www.404manual.com>

<http://www.luxmanual.com>

<http://aubethermostatmanual.com>

Golf course search by state

<http://golfingnear.com>

Email search by domain

<http://emailbydomain.com>

Auto manuals search

<http://auto.somanuals.com>

TV manuals search

<http://tv.somanuals.com>