

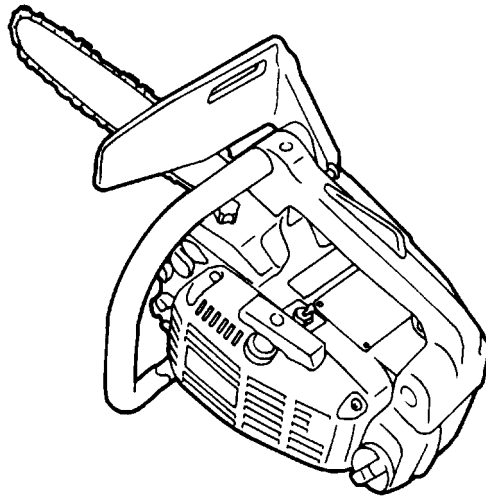

OWNER/OPERATOR MANUAL

CHAINSAWS

G310TS



WARNING



The engine exhaust from this product contains chemicals known to the State of California to cause cancer, birth defects or other reproductive harm.



WARNING



Before using our products, please read this manual carefully to understand the proper use of your unit.

APPLICABLE SERIAL NUMBERS :

002191 and up



SAFETY FIRST

Instructions contained in warnings within this manual marked with a  symbol concern critical points which must be taken into consideration to prevent possible serious bodily injury, and for this reason you are requested to read all such instructions carefully and follow them without fail.

■ **WARNINGS IN THE MANUAL**



This mark indicates instructions which must be followed in order to prevent accidents which could lead to serious bodily injury or death.



This mark indicates instructions which must be followed, or it leads to mechanical failure, breakdown, or damage.



This mark indicates hints or directions useful in the use of the product.

CONTENTS

1. Parts location	4
2. Specifications	4
3. Symbols on the machine	5
4. For safe operation	6
5. Installing guide bar and saw chain	8
6. Fuel and chain oil	9
7. Operation	11
8. Sawing	14
9. Maintenance	17
10. Storage	20
11. Parts list	21

1. Parts location

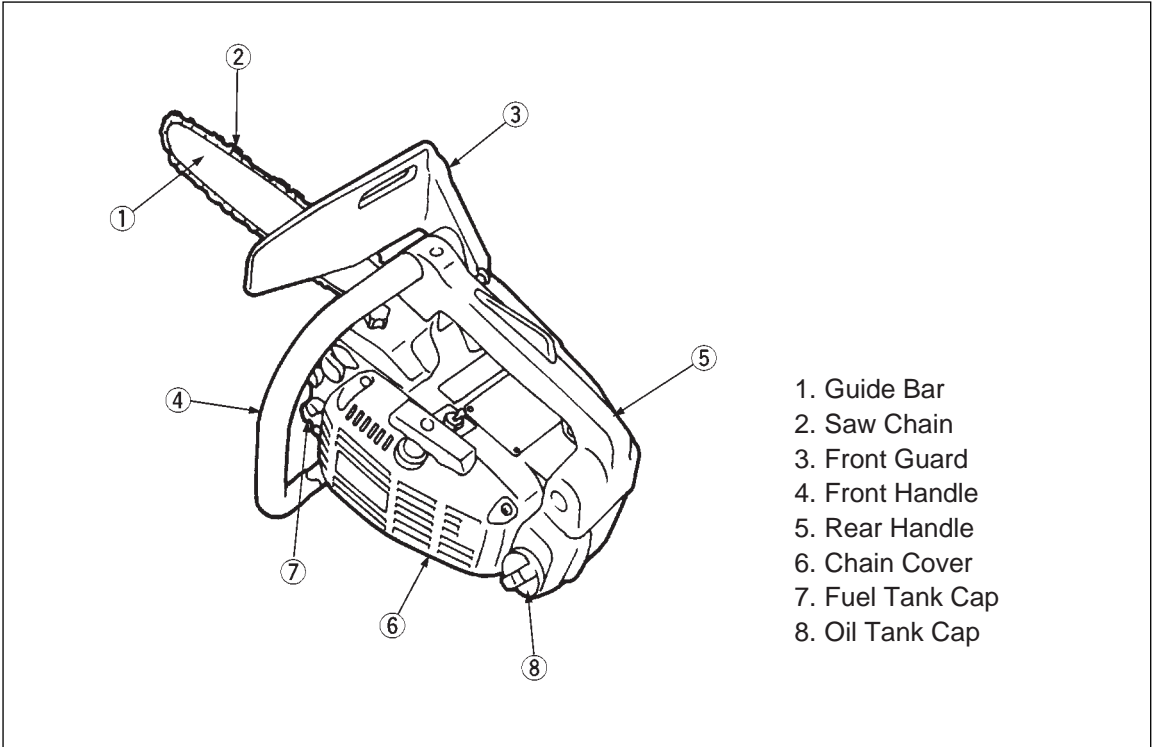

2. Specifications

■ G310TS

Power unit :

Dis placement	1.9(30.1) cu-in(cm ³)
Fuel	Mixture(Gasoline 32 : 2-cycle oil 1)
Fuel tank capacity	7.44(0.22) fl.oz(ℓ)
Chain oil	Motor oil SAE #10W-30
Oil tank capacity	4.40(0.13) fl.oz(ℓ)
Carburetor	Diaphragm type
Ignition system	Solid-state
Spark plug	Champion RCJ-6Y
Oil feeding system	Mechanical plunger pump
Sprocket : Pitch – No. of teeth	3/8in(9.38mm) – 6T
Dimensions : L – W – H	10.2(255)x9.2(230)x9.4(235) in(mm)
Dry weight	7.4(3.3) lbs(kg)

Cutting attachment :

Guide bar : Type – Size	Sprocket nose – 14(35) in(cm)
Saw chain : Type – Pitch – Gauge	Oregon 91SG – 3/8(9.375) – 0.050(1.25) in(mm)

Specifications are subject to change without notice.

3. Symbols on the machine

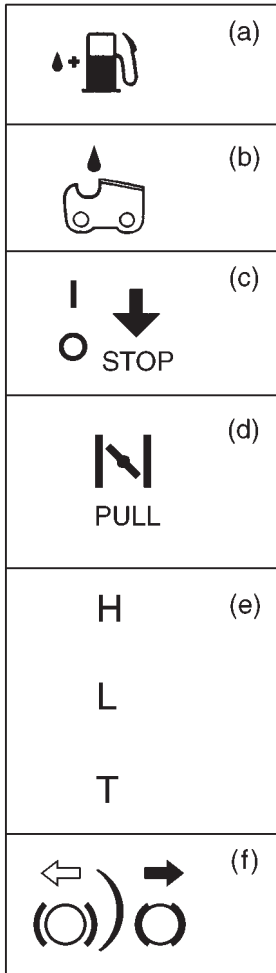

For safe operation and maintenance, symbols are on the machine. According to these indications, please be careful not to take a mistake.

(a). The port to refuel the “MIX GASOLINE”

Position: fuel tank cap

(b). The port to refuel the “CHAIN OIL”

Position: oil cap

(c). The indication regarding the switch.

Flipping the engine switch to the “O” (STOP) direction, the engine stops.

Position: upper part of the unit

(d). The indication regarding the choke.

Pulling out the choke knob, the choke closes.

Position: front of the chain cover

(e). The position of H-needle

The position of L-needle

The position of idle adjusting screw

Position: Front of the chain cover

(f). It shows the directions that the chain brake is released (for the white arrow) and activated (for the black arrow).

Position: Front of the chain cover

IMPORTANT ENGINE INFORMATION

THIS ENGINE CONFORMS TO
US EPA PH1 AND 1995-1998
CALIFORNIA EMISSION REGULATIONS
FOR ULGE ENGINES.
ENGINE FAMILY : TKZ030UB24RA
ENGINE DISPLACEMENT : 30.1cc
USE UNLEADED GASOLINE + AIR – COOLED
2 – CYCLE ENGINE OIL.
REFER TO OWNER'S MANUAL FOR
MAINTENANCE SPECIFICATIONS AND
ADJUSTMENTS.

ZENOAH **KOMATSU ZENOAH CO.**
KOMATSU RedMax Made in Japan

G310TS

INFORMATION IMPORTANTE CONCERNANT LE MOTEUR

Ce moteur conformc aux normes U.S. EPA PH1 et
1995-1998 de la réglementation concernant la
pollution de l'air pour les petits moteurs tout-terrain.
Type de moteur : TKZ025UB24RA
Cylindrée du moteur : 30,1 cc
Utiliser l'essence ordinaire (avec ou sans plomb) +
moteur 2-temps à refroidissement par air.
Se référer au Manuel de l'utilisateur pour
les spécifications d'entretien et les réglages.

ZENOAH **KOMATSU ZENOAH CO.**
KOMATSU RedMax Made in Japan

G310TS



4. For safe operation

1. Never operate a chain saw when you are fatigued, ill, or upset, or under the influence of medication that may make you drowsy, or if you are under the influence of alcohol or drugs.
2. Use safety footwear, snug fitting clothing and eye, hearing and head protection devices.
3. Always use caution when handling fuel. Wipe up all spills and then move the chain saw at least ten(10) feet(three(3) m) from the fueling point before starting the engine.
 - 3a) Eliminate all sources of sparks or flame (ie. smoking, open flames, or work that can cause sparks) in the areas where fuel is mixed, poured, or stored.
 - 3b) Do not smoke while handling fuel or while operating the chain saw.
4. Do not allow other persons to be near the chain saw when starting the engine or cutting a wood. Keep bystanders and animals out of the work area. Children, pets, and bystanders should be a minimum of thirty(30) feet away when you start or operate the chain saw.
5. Never start cutting until you have a clear work area, secure footing, and planned retreat path from the falling tree.
6. Always hold the chain saw firmly with both hands when the engine is running. Use a firm grip with thumb and fingers encircling the chain saw handles.
7. Keep all parts of your body away from the saw chain when the engine is running.
8. Before you start the engine, make sure the saw chain is not contacting anything.
9. Always carry the chain saw with the engine stopped, the guide bar and saw chain to the rear, and the muffler away from your body.
10. Always inspect the chain saw before each use for worn, loose, or changed parts. Never operate a chain saw that is damaged, improperly adjusted, or is not completely and securely assembled. Be sure that the saw chain stops moving when the throttle control trigger is released.
11. All chain saw service, other than the items listed in the Operator's Manual, should be performed by competent chain saw service personnel. (e.g., if improper tools are used to remove the flywheel, or if an improper tool is used to hold the flywheel in order to remove the clutch, structural damage to the flywheel could occur which could subsequently cause the flywheel to disintegrate).
12. Always shut off the engine before setting it down.
13. Use extreme caution when cutting small size brush and saplings because slender material may catch the saw chain and be whipped toward you or pull you off balance.
14. When cutting a limb that is under tension, be alert for spring back so that you will not be struck when the tension in the wood fibers is released.
15. Keep the handles dry, clean and free of oil or fuel mixture.



4. For safe operation

16. Operate the chain saw only in well ventilated areas. Never start or run the engine inside a closed room or building. Exhaust fumes contain dangerous carbon monoxide.
17. Do not operate a chain saw in a tree unless specially trained to do so.
18. Guard against kickback. Kickback is the upward motion of the guide bar which occurs when the saw chain at the nose of the guide bar contacts an object. Kickback can lead to dangerous loss of control of the chain saw.
19. When transporting your chain saw, make sure the appropriate guide bar scabbard is in place.
20. This chain saw is equipped with a spark arrester built-in muffler. Periodically check the arrester to keep it in good order.

KICKBACK SAFETY PRECAUTIONS FOR CHAIN SAW USERS

– WARNING –

- Kickback may occur when the nose or tip of the guide bar touches an object, or when the wood closes in and pinches the saw chain in the cut. Tip contact in some cases may cause a lightning fast reverse reaction, kicking the guide bar up and back towards the operator. Pinching the saw chain along the top of the guide bar may push the guide bar rapidly back towards the operator. Either of these reactions may cause you to lose control of the saw which could result in serious personal injury.
- Do not rely exclusively on the safety devices built into your saw. As a chain saw user you should take several steps to keep cutting jobs free from accident or injury.
 - (1) With a basic understanding of kickback you can reduce or eliminate the element of surprise. Sudden surprise contributes to accidents.
 - (2) Keep a good grip on the saw with both hands, the right hand on the rear handle, and the left hand on the front handle, when the engine is running. Use a firm grip with thumbs and fingers encircling the chain saw handles. A firm grip will help you reduce kickback and maintain control of the saw. Don't let go.
 - (3) Make certain that the area in which you're cutting is free from obstructions. Do not let the nose of the guide bar contact a log, branch, or any other obstruction which could be hit while you are operating the saw.
 - (4) Cut at high engine speeds.
 - (5) Do not overreach or cut above shoulder height.
 - (6) Follow manufacturers sharpening and maintenance instructions for saw chain.
 - (7) Only use replacement bars and chains specified by the manufacturer or the equivalent.

5. Installing guide bar and saw chain

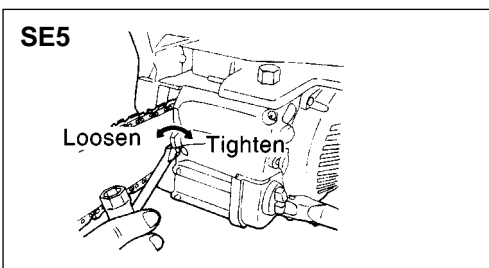
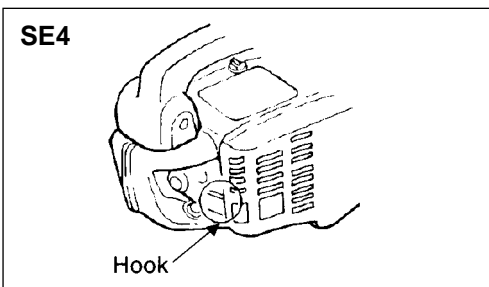
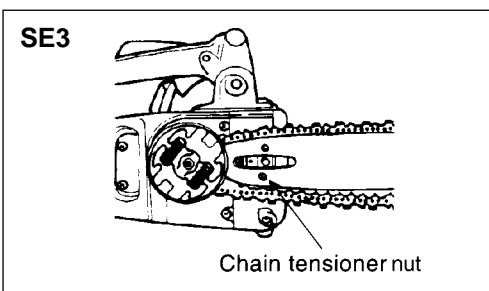
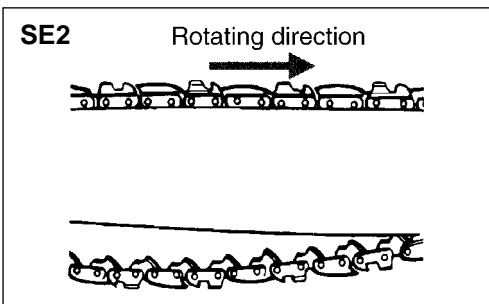
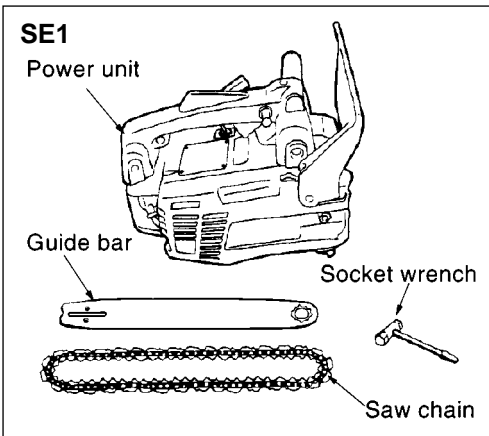

A standard saw unit package contains the items as shown. (SE1)

Open the box and install the guide bar and the saw chain to the power unit as follows.

WARNING

The saw chain has very sharp edges. Use thick, protective gloves to avoid injury.

1. Loosen a nut and remove the chain cover.
2. Mount the guide bar and fit the saw chain around the bar and the drive sprocket. Pay attention to the correct direction of the saw chain. (SE2)
3. Fit the chain tensioner nut into the lower hole of the guide bar, then install the chain cover, and fasten the mounting nut to finger tightness. (SE3)

NOTE

When installing the chain cover, be sure to fit the hook completely at the rear end of the cover. (SE4)

4. While holding up the tip of the bar, adjust the chain tension by turning the tensioner screw until the tie straps just touch the bottom side of the bar rail. (SE5)
5. Keep holding the guide bar up, tighten the mounting nut firmly with the attached socket wrench.
6. Rotate the saw chain by hand, wearing a protective glove, to see if it turns smoothly without noticeable gap between the tie straps and the guide bar.

NOTE

A new chain will expand its length in the beginning of use. Check and readjust the tension frequently as a loose chain can easily derail or cause rapid wear of itself and the guide bar.

6. Fuel and chain oil

■ FUEL

The RedMax engines are lubricated by oil specially formulated for air-cooled 2-cycle gasoline engine use. If RedMax oil is not available, use an anti-oxidant added quality oil expressly labeled for air-cooled 2-cycle engine use.

RECOMMENDED MIXING RATIO GASOLINE 32 : OIL 1

Exhaust emission are controlled by the fundamental engine parameters and components (eq., carburation, ignition timing and port timing) without addition of any major hardware or the introduction of an inert material during combustion.

These engines are certified to operate on unleaded gasoline.

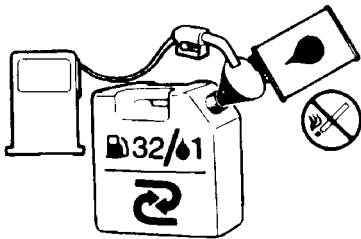

▲ WARNING

The fuel is highly flammable. Do not smoke or bring any flame or sparks near fuel.

■ HOW TO MIX FUEL

1. Measure out the quantities of gasoline and oil to be mixed.
2. Put some of the gasoline into a clean, approved fuel container.
3. Pour in all of the oil and agitate well.
4. Pour in the rest of gasoline and agitate again for at least one minute.
5. Put a clear indication on the outside of the container to avoid mixing up with gasoline or other containers.

FOR YOUR ENGINE LIFE, AVOID;

1. FUEL WITH NO OIL(RAW GASOLINE) – It will cause severe damage to the engine inner parts very quickly.
2. GASOHOL – It can cause deterioration of rubber and/or plastic parts and disruption of engine lubrication.
3. OIL FOR 4-CYCLE ENGINE USE or WATER COOLED 2-CYCLE ENGINE USE – It can cause spark plug fouling, exhaust port blocking, or piston ring sticking.

6. Fuel and Chain oil

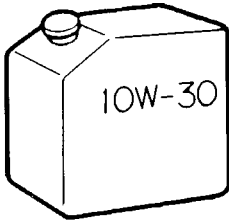

■ CHAIN OIL

Use motor oil SAE 10W-30 all year round, or SAE 30-40 in summer and SAE 20 in winter.



Do not use waste or regenerated oil that can cause damage to the oil pump.

7. Operation

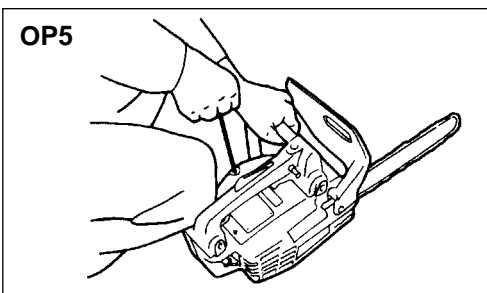
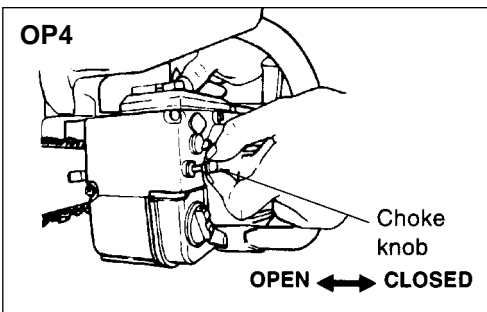
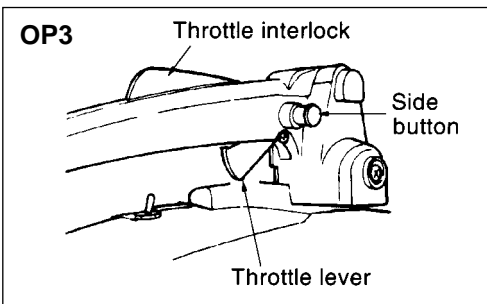
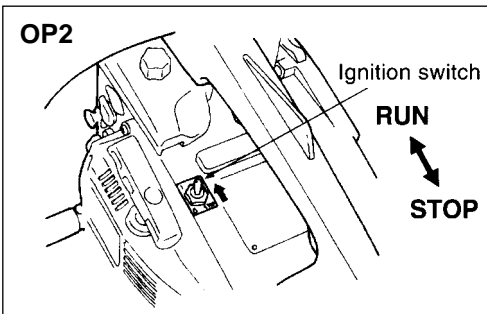
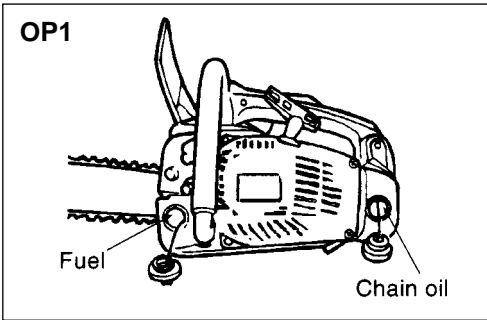

■ FUELING THE UNIT (OP1)

1. Remove the fuel tank cap and pour fuel into the tank up to 80% of full capacity.
2. Fasten the fuel cap securely and wipe up any fuel spillage around the unit.
3. Remove the oil tank cap and pour chain oil into the tank. Fasten the cap securely.

⚠ WARNING

1. Select bare ground for fueling.
2. Move at least 10 feet (3 meters) away from the fueling point before starting the engine.
3. Stop the engine before refueling the unit.

■ STARTING ENGINE

⚠ WARNING

Keep clear of the saw chain as it will start rotating upon starting of the engine.

1. Put the ignition switch to "I" position. (OP2)
2. While holding the throttle lever together with the throttle interlock, push in the side button and release the throttle lever to hold it at the start position. (OP3)
3. Pull out the choke knob to the closed position. (OP4)

📖 NOTE

When restarting immediately after stopping the engine, leave the choke knob at the open position.

4. While holding the saw unit securely on the ground, pull the starter rope vigorously. (OP5)

⚠ WARNING

Do not start the engine while hanging the chain saw with a hand. The saw chain may touch your body. It's very dangerous.

5. When engine has ignited first, push in the choke knob and pull the rope again to start the engine.
6. Allow the engine to warm up with the throttle lever pulled slightly.

7. Operation

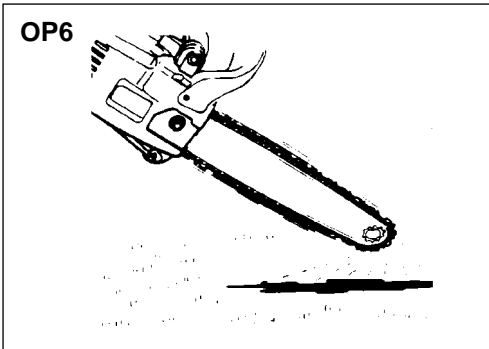

■ CHECKING OIL SUPPLY

After starting the engine, run the chain at medium speed and see if chain oil is scattered off as shown in the figure. (OP6)

NOTE

The oil tank should become nearly empty by the time fuel in the tank is used up. Be sure to refill the oil tank every time when refueling the saw.

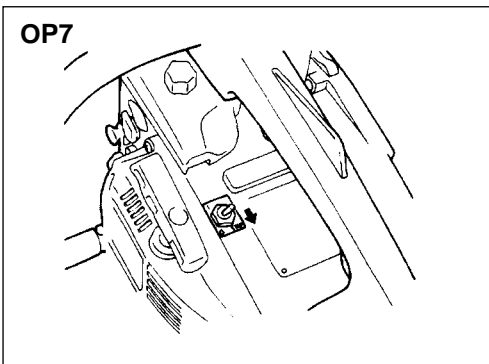

■ STOPPING ENGINE

1. Release the throttle lever and let the engine run at low speed for a moment.
2. Put the ignition switch to the "O" position. (OP7)

NOTE

In case of emergency, turn off the switch without idling the engine.

■ ADJUSTING CARBURETOR

The carburetor has been adjusted at the factory. Should your unit need readjustment due to the changes in altitude or operating conditions, please let your skillful dealer make the adjustment. A wrong adjustment may cause damage to your unit. If you have to make the adjustment yourself, please carefully follow the procedure below.

NOTE

Be sure to adjust the carburetor with the bar chain attached.

1. H and L needles are restricted within the number of turn as shown below, because this engine conforms to 1995 California regulations for utility and lawn and garden equipment engines as applicable. (OP8)

H needle -1/2
L needle fixed

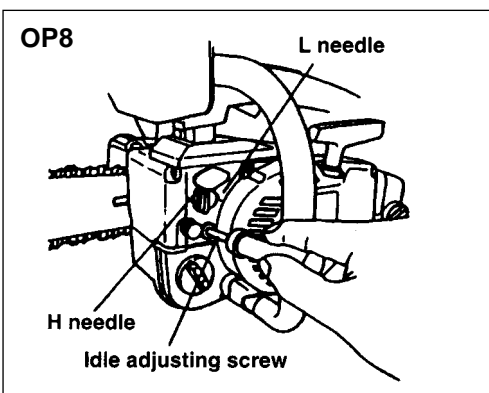

2. Start engine and allow it to warm up in low speed for a few minutes. (OP8)
3. Turn idle adjusting screw (T) counter-clockwise

7. Operation

so that saw chain does not turn. If idling speed is too slow, turn the screw clockwise. (OP8)

4. Make a test cut adjust the H needle for best cutting power, not for maximum speed. (OP8)

■ CHAIN BRAKE

The chain brake is a device designed to stop the saw chain quickly when kickback occurred.

The brake system equipped on the G310TS units is designed to work automatically by sensing reaction force. It can also be activated manually by pushing the brake lever (front hand guard) down forward.

A yellow cone popping up from the base of the brake lever indicates that the brake is on.

Releasing the Brake

Pull the brake lever up toward the front handle until it clicks. (OP9)

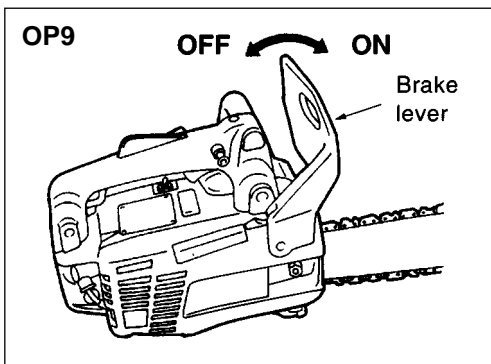

NOTE

- When the brake worked, immediately release the throttle lever and slow down the engine speed. Running the engine at high speed while braking the saw chain can cause clutch failures.
- Before starting the day's job, check the condition of the brake system as follows:
 - 1) Start the engine and grasp the handles securely with both hands.
 - 2) While pulling the throttle lever, slowly push the brake lever (front hand guard) forward with the back of your left hand.
 - 3) Check that the brake works normally, then release the throttle lever.
 - 4) Pull the brake lever back to the OFF position.

8. Sawing

NOTE

- Before proceeding to your job, read “For Safe Operation” section. It is recommended to first practice sawing easy logs. This also helps you get accustomed to your unit.
- It is not necessary to force the saw into the cut. Apply only light pressure while running the engine at full throttle.
- Racing the engine with the chain seized in a cutaway can damage the clutch system. When the saw chain is caught in the cut, do not attempt to pull it out by force, but use a wedge or a lever to open the cut.

■ GUARD AGAINST KICKBACK

- This saw is equipped with a special “low kickback” chain that greatly reduces the severity of kickback should it occur.
- The saw chain has been tested in accordance with American National Standard Safety Specifications for gasoline powered chain saw (ANSI B175.1 1985) as having an acceptable low kickback level. On this saw never use any chain other than those recommended on page 18 of this manual, or which is not designated as meeting the ANSI B175.1 kickback levels on this saw.
- Low kickback saw chains are chains which have met the kickback requirements of ANSI B175.1 when tested on the representative samples of chain saws below 3.8 C.I.D. specified in ANSI B175.1.
- The guide bar supplied with this saw has an under 1.2 inch radius sprocket nose which produces a specific kickback energy. Never use a bar with a larger nose radius. Use only those recommended on page 18.
- The length of bars has a great effect on kickback. Use only those length as specified on page 18.
- This saw is also equipped with a chain brake that will stop the chain in the event of kickback if operating properly. You must check the chain brake operation before each usage by running the saw at full throttle for 1 or 2 seconds and pushing the front hand guard forward. The chain

8. Sawing

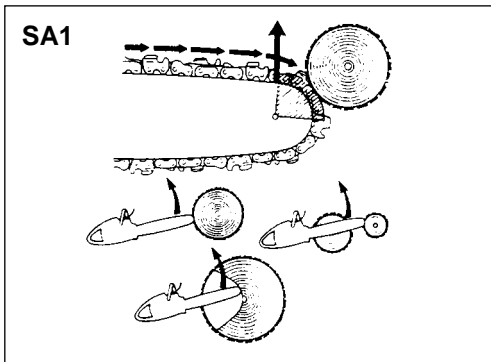

should stop immediately with the engine at full speed. If the chain is slow to stop or does not stop then replace the brake band and clutch drum before use.

- It is extremely important that the chain brake be checked for proper operation before each use and that the chain be sharp in order to maintain the kickback safety level of this saw. Removal of the safety devices, inadequate maintenance, or incorrect replacement of the bar or chain may increase the risk of serious personal injury due to kickback. (SA1)

■ FELLING A TREE (SA2)

▲ WARNING

When you fell a tree, be sure to warn your neighboring workers of the danger.

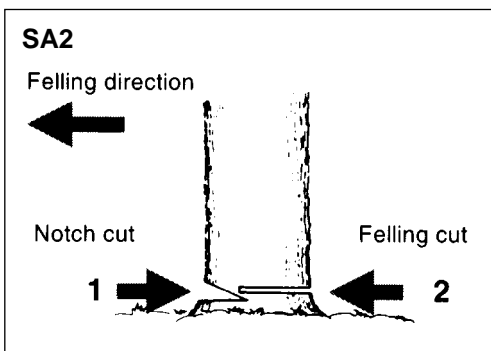

1. Decide the felling direction considering the wind, lean of the tree, location of heavy branches, ease of job after felling, and other factors .
2. While clearing the area around the tree, arrange a good foothold and retreat path.
3. Make a notch cut one-third of the way into the tree on the felling side.
4. Make a felling cut from the opposite side of the notch and at a level slightly higher than the bottom of the notch.

■ LOGGING AND LIMBING

▲ WARNING

1. **Always ensure your foothold as well as stability of the tree.**
2. **Be alert to the rolling over of a cut log.**
3. **Read the instructions in “For safe operation” to avoid kickback of the saw.**

Before starting work, check the direction of bending force inside the log to be cut. Always finish cutting from the opposite side

8. Sawing

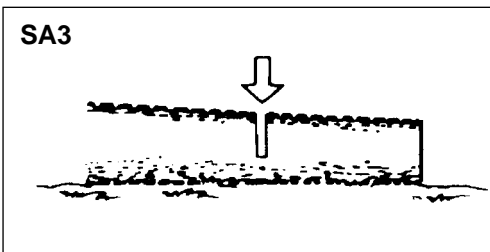

of bending direction to prevent the guide bar from being caught in the cutaway.

● Cutting an unpillowed log

Saw down halfway, then roll the log over and cut from the opposite side. (SA3)

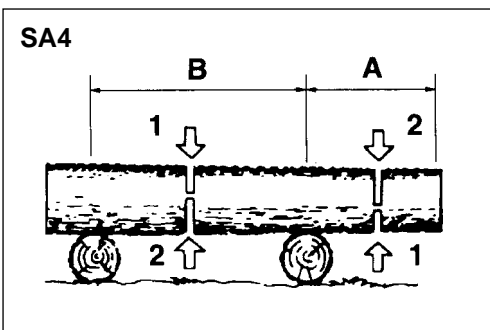

● Cutting a pillowed log

In the area A in the picture right above, saw up from the bottom one-third and finish by sawing down from the top. In the area B, saw down from the top one-third and finish by sawing up from the bottom. (SA4)

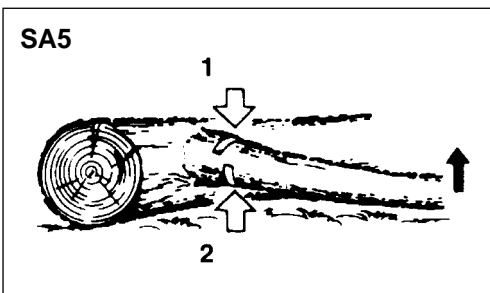

● Limbing a felled tree



Be alert to the spring back of a cut limb.

First check which way the limb is bent. Then make a shallow cut into the compressed side to prevent the limb from being torn. Cut through from the tensed side. (SA5)

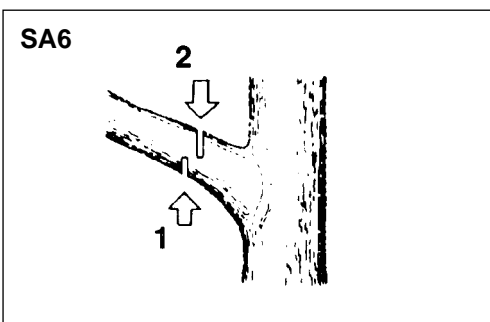

● Pruning



1. Do not use an unstable foothold or a stepladder.
2. Do not overreach.
3. Do not cut above shoulder height.
4. Always use both hands to grip the saw.

Cut up from the bottom, finish down from the top. (SA6)

9. Maintenance

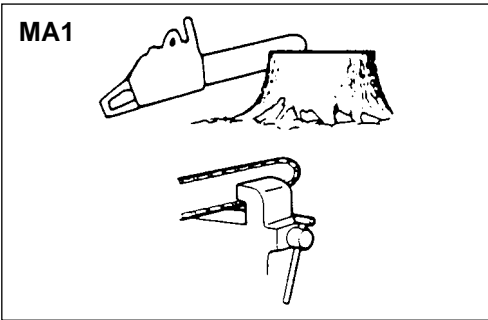

⚠ WARNING

Make sure to stop the engine before inspecting and/or servicing the unit.

■ DAILY MAINTENANCE

SAW CHAIN

It is one of the essential factors for smooth and safe operation to keep the cutters always in good condition. It's time to reform the cutters when;

1. Sawdust has become powder-like.
2. You need extra force to saw in.
3. The cutaway tends to curve by itself.
4. The unit vibrates abnormally when sawing.
5. Fuel consumption has increased.

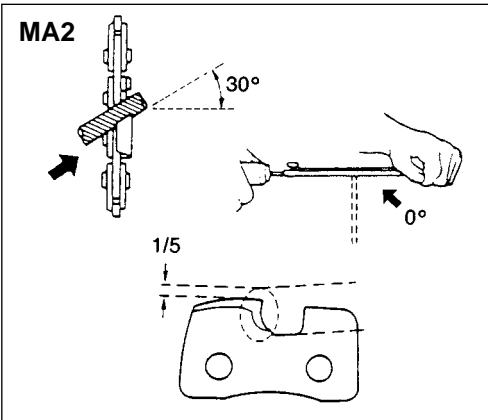

REFORMING CUTTER

1. Wear work gloves.
2. Use 5/32 inch (3.9mm) round file.
3. Hold the guide bar and the saw chain firmly.
4. Place the file on the cutter and push straight forward while keeping the file angles and the height as shown in the picture.
5. Make sure that every cutter has the same length and the edge angles as shown in the picture.
6. After every cutter has been set, check the depth gauge and file it to the proper level as necessary. Do not file off beyond the specified level, or the cutting edge can be damaged very quickly.

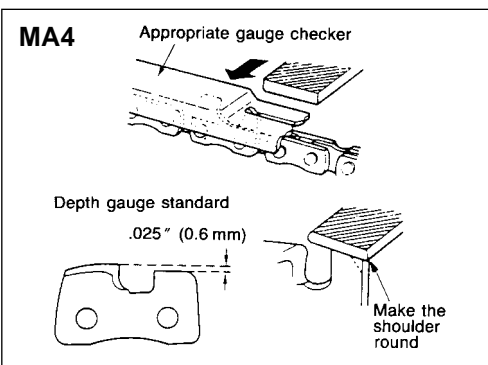
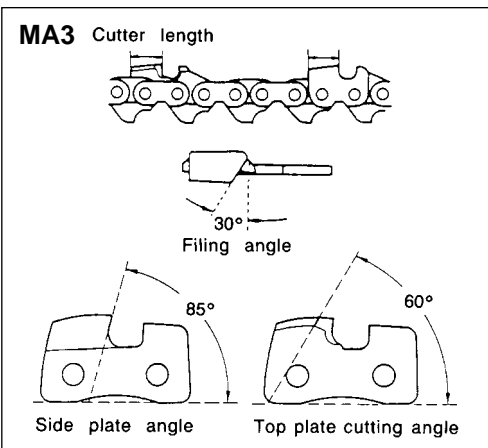

9. Maintenance

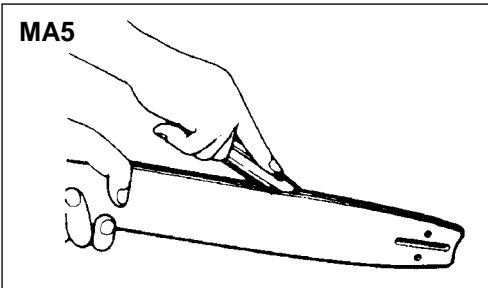

GUIDE BAR

1. Remove sawdust in the bar groove and the oiling port. (MA5)
2. Grease the nose sprocket from the feeding port on the tip of the guide bar. (MA6)
3. Periodically turn over the guide bar when mounting it to the unit, in order to prevent partial wear.

⚠ WARNING

This saw is equipped with one of the following low kickback bar/chain combinations:

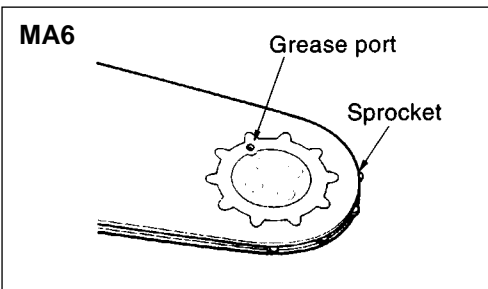

Bar Size	RedMax Part Number	
	Guide Bar	Saw Chain
14 (inch) (35cm)	G0011	91SG52X

For replacement, use only above bar and chain, or the following;

OREGON BAR

14 inch S/N DOUBLE GUARD BAR,
Mount code #A041.

OREGON CHAIN

91SG

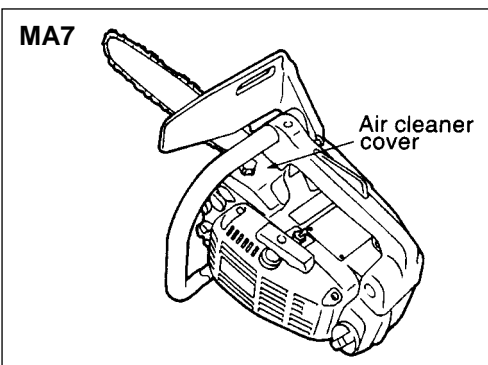

AIR FILTER

A clogged air filter can reduce the engine performance. Daily check the filter elements and tap off attached saw dust. When cleaning, use warm, soapy water and dry completely before installing. When the element is broken or shrunk, replace with a new one. (MA7)

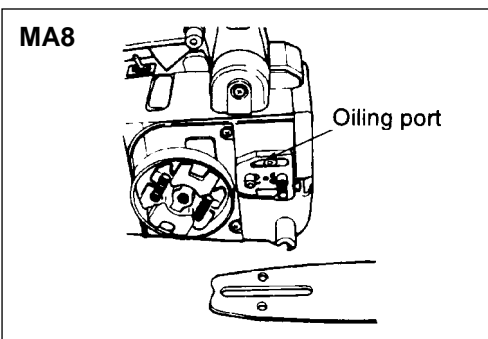

OILING PORT

Dismount the guide bar and check the oiling port for blocking by sawdust. (MA8)

GENERAL

Inspect the entire unit for fuel leakage, loose fastenings, and damage to major parts, especially handle joints and guide bar mounting. When

9. Maintenance

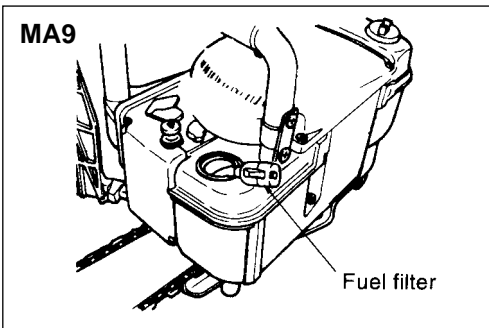

anything wrong be found, make sure to have it repaired before next usage.

■ MONTHLY MAINTENANCE

FUEL FILTER

When the engine runs short of fuel supply, check the fuel filter for blockage. (MA9)

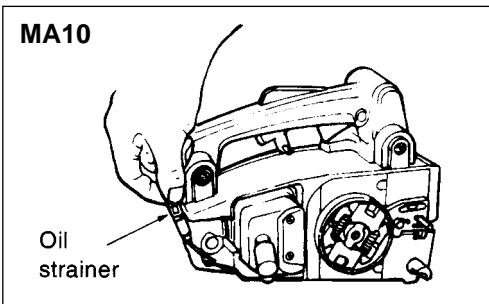

OIL STRAINER

Drain the oil tank and remove the oil strainer located near the spark plug. Check the condition and clean if necessary. (MA10)

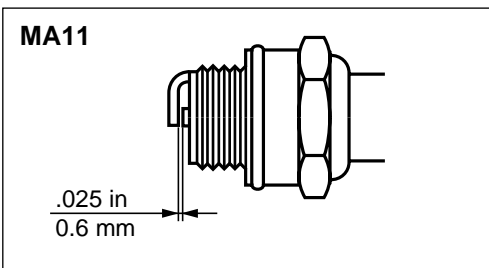

SPARK PLUG

Starting failure and mis-firing are often caused by a fouled spark plug. Periodically clean the spark plug and check that the spark gap is in the correct range. (MA11)

For a replacement plug, use Champion RCJ-6Y(noise-proof) or CJ-6Y, or NGK BPMR7A.

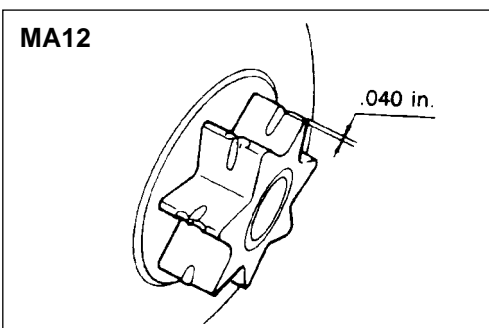

DRIVE SPROCKET

Periodically check the drive sprocket for wear and damage, and replace when the teeth have worn over 0.04 inch, or when any damage has been observed. (MA12)

HANDLE MOUNTING JOINTS

Inspect the handle mounting joints and replace when any adhered part is peeled off or a crack is observed on the rubber part. Also replace when the inside of the rear damper metal has worn remarkably.

9. Maintenance

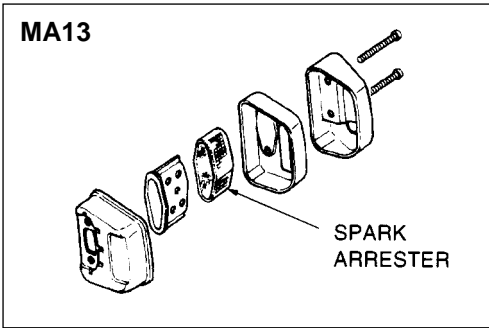

SPARK ARRESTER

RedMax engines are equipped with a spark arresting screen at the exhaust port. Periodically check and keep it in good condition. In the State of California it is required by law (Section 4442 of the California Public Resources Code) to have a spark arrester when a gas powered tool is used in any forest covered, brush covered, or grass covered unimproved land. (MA13)

10. Storage

1. Empty the fuel tank and run the engine out of fuel.
2. Empty the oil tank.
3. Clean the entire unit.
4. Store the unit in a dry place out of the reach of children.

11. Parts list

CHAINSAWS

G310TS

NOTE :

1. Use KOMATSU ZENOAH genuine parts as specified in the parts list for repair and/or replacement.
2. KOMATSU ZENOAH does not warrant the machines, which have been damaged by the use of any parts other than those specified by the company.
3. When placing parts orders for repair and/or replacement, check if the model name and the serial number are applicable to those specified in the parts list, then use parts number described in the parts list.
4. The contents described in the parts list may change due to improvement.
5. The parts for the machine shall be supplied seven (7) years after the machine is discontinued. [It is possible that some specific parts may be subject to change of their delivery term and list price within the limit of ten (7) years after the machine is discontinued. It is also possible that some parts may be available even after the limit of seven (7) years.]

APPLICABLE SERIAL NUMBERS : 002191 and up

May. 2000

**Fig.1 POWER UNIT
G310TS
(S/N 002191 and up)**

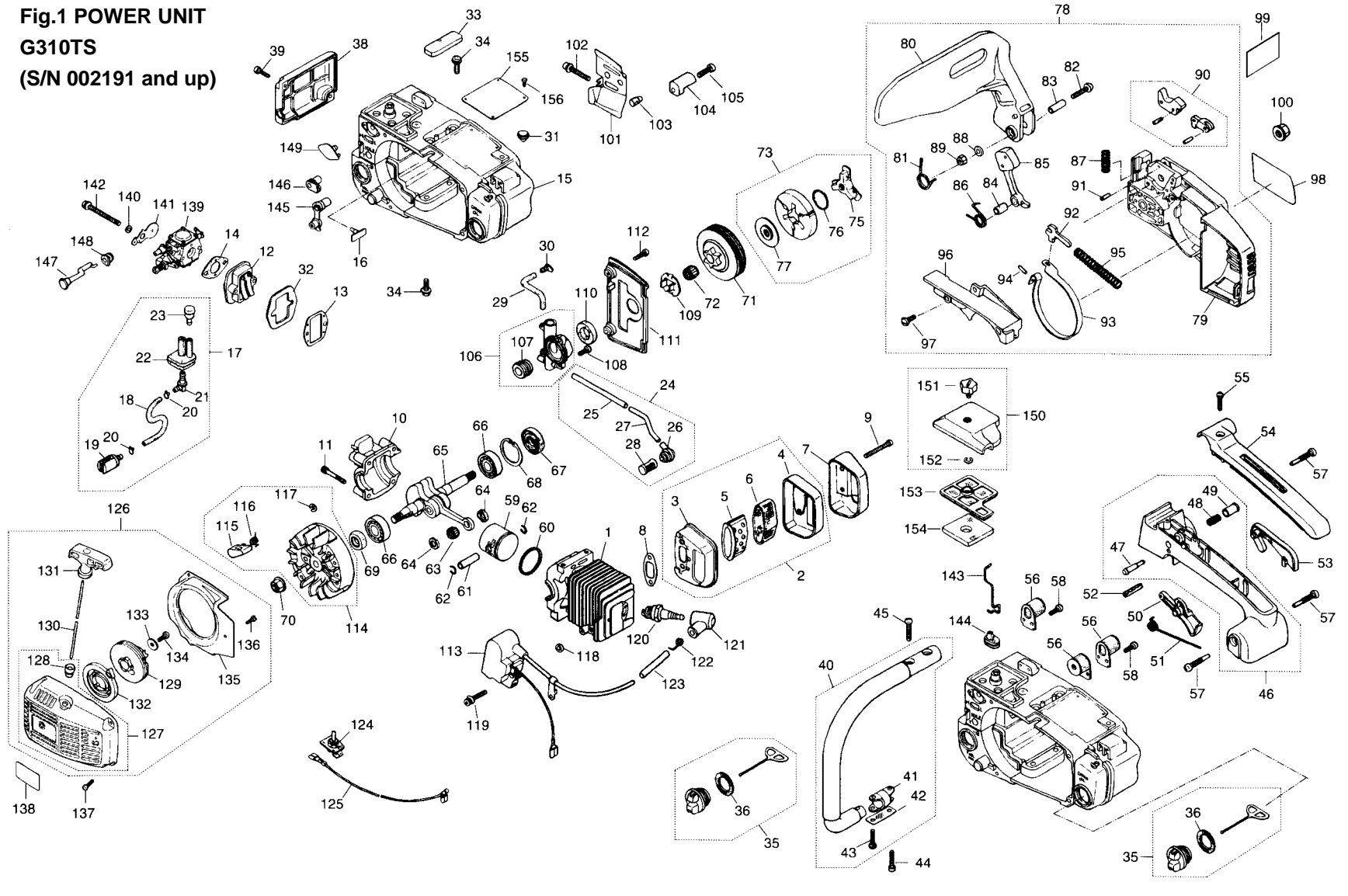

Key#	PART NUMBER	DESCRIPTION	Q'TY /UNIT	NOTE
1	2870-12111	CYLINDER	1	
2	2633-15100	MUFFLER ASS'Y	1	
3	2633-15110	• BASE	1	
4	2633-15120	• COVER	1	
5	2630-15130	• BUFFLE	1	
6	2633-15150	• SPARK ARRESTER	1	
7	2633-15160	COVER	1	
8	2630-15210	GASKET	1	
9	3330-15220	BOLT	2	
10	2870-21111	CRANKCASE	1	
11	01252-30530	BOLT	4	
12	2870-22102	VALVE ASS'Y	1	
13	2870-22211	GASKET	1	
14	3330-141211	GASKET	1	
15	2875-31103	ENGINE CASE COMP.	1	
16	2870-31510	VALVE	1	
17	2831-31202	FUEL PIPE ASS'Y	1	
18	1492-85410	• PIPE	1	
19	1850-85300	• FILTER ASS'Y	1	
20	1260-85460	• CLIP	2	
21	3350-34320	• ELBOW	1	
22	2631-31250	• GROMMET	1	
23	3317-86100	• BREATHER ASS'Y	1	
24	2630-31301	OIL PIPE ASS'Y	1	
25	1492-85410	• PIPE	1	
26	2630-31321	• GROMMET	1	
27	2630-31330	• JOINT	1	
28	2630-31350	• FILTER	1	
29	1492-85410	PIPE	1	
30	3370-31210	PIN	1	
31	2630-31510	VALVE ASS'Y	1	
32	2870-22251	SEAL	1	
33	2630-31650	CAP	1	
34	2870-31750	SCREW	4	
35	2841-31800	CAP ASS'Y	2	
36	2630-31820	• GASKET	2	
37		STOPPER		
38	2630-31913	COVER	2	
39	2630-31950	SCREW	2	
40	2632-32103	FRONT HANDLE ASS'Y	1	
41	2630-32121	• JOINT (A)	1	
42	2630-32151	• STOPPER	1	
43	2630-32170	• SCREW	1	
44	2630-32170	SCREW	1	
45	2630-32610	SCREW	1	
46	2630-33103	REAR HANDLE COMP.	1	
47	3330-33250	• STOPPER	2	
48	3310-33262	• SPRING	1	
49	3310-33271	• KNOB	1	
50	2630-33312	THROTTLE LEVER	1	
51	3356-33321	SPRING	1	
52	04025-00524	PIN	1	
53	3356-33352	ARM	1	

Key#	PART NUMBER	DESCRIPTION	Q'TY /UNIT	NOTE
54	2630-33410	COVER	1	
55	2630-31950	SCREW	1	
56	2630-33511	JOINT (B)	3	
57	2640-33530	BOLT	3	
58	2630-33610	SCREW	6	
59	2870-41111	PISTON	1	
60	3319-41210	RING	1	
61	3304-41310	PIN	1	
62	3310-41320	SNAP RING	2	
63	3310-41410	BEARING	1	
64	1650-41510	WASHER	2	
65	2870-42002	CRANKSHAFT COMP.	1	
66	06030-06201	BEARING	2	
67	2630-43150	OIL SEAL	1	
68	04065-03212	SNAP RING	1	
69	2169-21210	OIL SEAL	1	
70	1650-43230	NUT	1	
71	2872-51111	CLUTCH DRUM	1	
72	3310-51310	BEARING	1	
73	2870-51200	CLUTCH ASS'Y	1	
74		• SHOE		
75	3317-51240	• BOSS (B)	1	
76	2870-51230	• SPRING	1	
77	2630-98610	• BOSS (A)	1	
78	2872-54004	CHAIN BRAKE ASS'Y	1	
79	2872-53115	• COVER	1	
80	2872-54112	• GUARD	1	
81	2872-54120	• SPRING	1	
82	0263-80530	• SCREW	1	
83	2872-54140	• SPACER	1	
84	2850-54211	• SPACER	1	
85	2872-54220	• WEIGHT	1	
86	2872-54230	• SPRING	1	
87	2851-54270	• SPRING	1	
88	01641-20508	• WASHER	1	
89	3310-53331	• NUT (B)	1	
90	2851-54301	• LEVER COMP.	1	
91	2851-54350	• PIN	1	
92	2670-54410	• ARM	1	
93	2872-54510	• BAND	1	
94	3356-24140	• PIN	1	
95	2670-54610	• SPRING	1	
96	2872-54623	• COVER	1	
97	2630-33610	• SCREW	3	
98	2831-54120	LABEL	1	
99	2648-54350	LABEL	1	
100	3350-53410	NUT	1	
101	2870-53310	PLATE	1	
102	2630-53330	SCREW	1	
103	3310-53320	NUT (A)	1	
104	2630-53412	CATCHER	1	
105	2630-32170	SCREW	1	
106	2630-55103	OIL PUMP ASS'Y	1	

Key#	PART NUMBER	DESCRIPTION	Q'TY /UNIT	NOTE
107	2630-55160	• GEAR	1	
108	0261-00416	SCREW	2	
109	2630-55211	PLATE	1	
110	2630-55251	SEAL	1	
111	2630-55312	COVER	1	
112	2630-31950	SCREW	2	
113	2634-71111	MODULE	1	
114	2631-71203	ROTOR ASS'Y	1	
115	2630-71221	• PAWL	2	
116	2630-71231	• SPRING	2	
117	0308-00040	• SNAP RING	2	
118	5600-72150	SPACER	2	
119	3310-72150	BOLT	2	
120	5602-73110	SPARK PLUG (RCJ8Y)	1	
121	5500-72110	CAP	1	
122	1900-72120	SPRING	1	
123	2630-72211	TUBE	1	
124	2634-72500	SWITCH ASS'Y	1	
125	2630-72610	LEAD	1	
126	2870-75002	STARTER ASS'Y	1	
127	2870-75101	• CASE COMP.	1	
128	3330-75121	•• GUIDE	1	
129	2630-75213	• REEL	1	
130	1260-75151	• ROPE	1	
131	3330-75421	• KNOB	1	
132	3330-75201	• HOLDER COMP.	1	
133	2630-75410	• WASHER	1	
134	2630-75510	• SCREW	1	
135	2870-75610	• COVER	1	
136	2630-33610	• SCREW	1	
137	2630-31950	SCREW	4	
138	2875-75130	LABEL	1	
139	2875-81001	CARBURETOR ASS'Y	1	
140	3310-82110	WASHER	1	
141	2875-82120	CHOKE PLATE	1	
142	2630-82140	SCREW	2	
143	2630-82151	THROTTLE ROD	1	
144	2630-82160	GROMMET	1	
145	2630-82210	GROMMET (A)	1	
146	2875-82221	GROMMET (B)	1	
147	2630-82311	CHOKE ROD	1	
148	3320-33310	GROMMET	1	
149	2631-82550	CAP	1	
150	2630-98500	COVER ASS'Y	1	
151	2630-83120	• KNOB	1	
152	0308-00040	• SNAP RING	1	
153	2630-83511	CLEANER	1	
154	2870-83610	ELEMENT	1	
155	2875-31411	LABEL	1	
156	0304-02040	RIVET	4	

Fig.1 POWER UNIT (S/N 002191 and up)

G310TS

Fig.2 CARBURETOR COMPONENTS & ACCESSORIES (S/N 002191 and up)

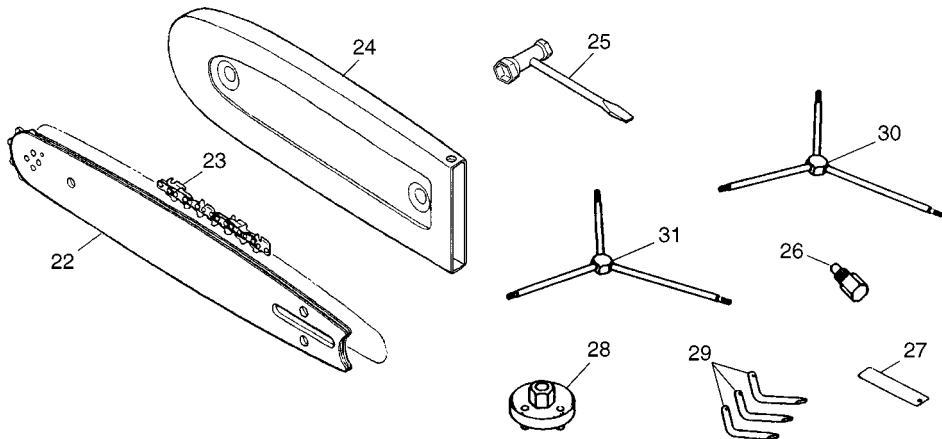
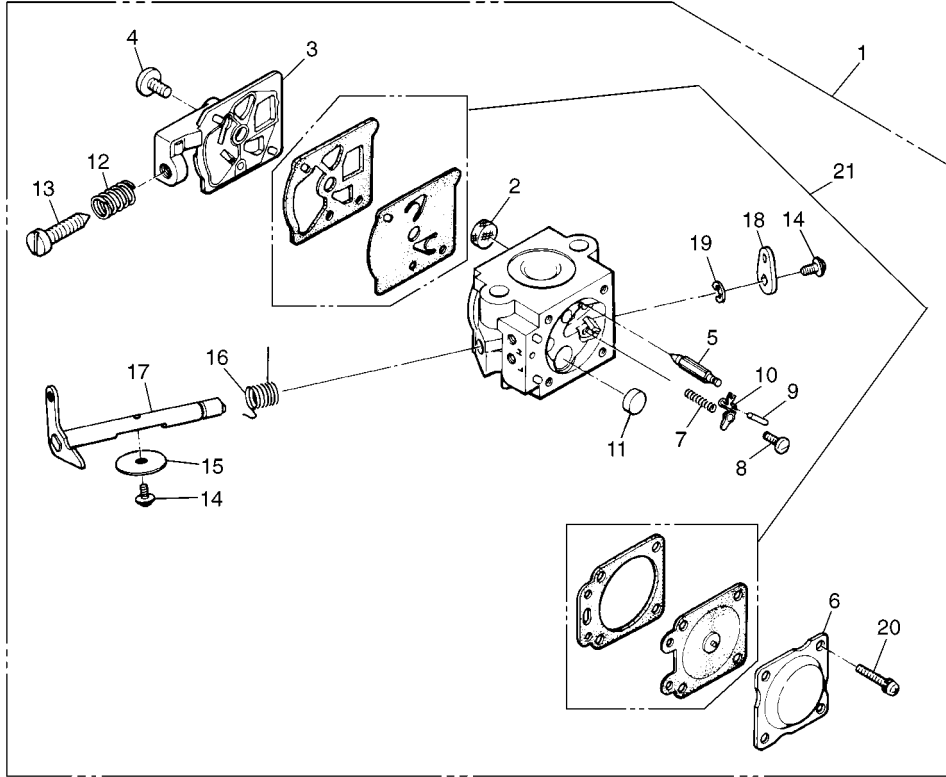

Fig.2 CARBURETOR COMPONENTS & ACCESSORIES (S/N 002191 and up)

Key#	PART NUMBER	DESCRIPTION	Q'TY /UNIT	NOTE	Key#	PART NUMBER	DESCRIPTION	Q'TY /UNIT	NOTE
1	2875-81001	CARBURETOR ASS'Y							
2	3306-81380	SCREEN	1						
3	2875-81120	PUMP COVER	1						
4	3310-81130	SCREW	1						
5	3356-81310	VALVE, inlet	1						
6	3310-81280	COVER	1						
7	2867-81270	SPRING	1						
8	3310-81240	SCREW	1						
9	3310-81250	PIN	1						
10	3310-81230	LEVER	1						
11	1480-81420	PLUG	1						
12	3350-81380	SPRING	1						
13	2630-81330	SCREW	1						
14	3310-81360	SCREW	2						
15	3310-81341	VALVE	1						
16	2670-81410	SPRING	1						
17	2875-81370	SHAFT ASS'Y	1						
18	2630-81440	LEVER	1						
19	1148-81390	RING	1						
20	3310-81351	SCREW	4						
21	2850-06020	GASKET KIT	1						
22	G0011	BAR 14" (350mm)	1						
23	91SG-52X	CHAIN 91SG-52E	1						
24	3617-97110	PROTECTOR	1						
25	3320-91140	WRENCH	1						
26	3320-96410	STOPPER	1	OP					
27	3330-97310	GUAGE	1	OP					
28	2670-96210	WRENCH	1	OP					
29	2670-96240	WRENCH	1	OP					
30	2670-96410								
		WRENCH TORX (T20 x T25 x T25)	1	OP					
31	3304-97611								
		WRENCH TORX (B3 x B4 x B5)	1	OP					

CALIFORNIA EMISSION CONTROL WARRANTY STATEMENT
YOUR WARRANTY RIGHTS AND OBLIGATIONS

THE CALIFORNIA AIR RESOURCES BOARD AND KOMATSU ZENOAH Co. ARE PLEASED TO EXPLAIN THE **EMISSION CONTROL SYSTEM WARRANTY** ON YOUR **1995 AND LATER** LAWN AND GARDEN EQUIPMENT ENGINE. IN CALIFORNIA, NEW UTILITY AND LAWN AND GARDEN EQUIPMENT ENGINES MUST BE DESIGNED, BUILT AND EQUIPPED TO MEET THE STATE'S STRINGENT ANTI-SMOG STANDARDS.

KOMATSU ZENOAH Co, MUST WARRANT THE EMISSION CONTROL SYSTEM ON YOUR LAWN AND GARDEN EQUIPMENT ENGINE FOR THE PERIODS OF TIME LISTED BELOW PROVIDED THERE HAS BEEN NO ABUSE, NEGLIGENCE OR IMPROPER MAINTENANCE OF YOUR LAWN AND GARDEN EQUIPMENT ENGINE.

YOUR EMISSION CONTROL SYSTEM. MAY INCLUDE PARTS SUCH AS THE CARBURETOR, THE IGNITION SYSTEM, AND CATALYTIC CONVERTER. ALSO INCLUDED MAY BE THE HOSES, BELTS, CONNECTORS AND OTHER EMISSION-RELATED ASSEMBLIES.

WHERE A WARRANTABLE CONDITION EXISTS, KOMATSU ZENOAH Co. WILL REPAIR YOUR LAWN AND GARDEN EQUIPMENT ENGINE AT NO COST TO YOU INCLUDING DIAGNOSIS, PARTS AND LABOR.

MANUFACTURER'S WARRANTY COVERAGE:

THE 1995 AND LATER UTILITY AND LAWN AND GARDEN EQUIPMENT ENGINES ARE WARRANTED FOR **TWO YEARS**. IF ANY EMISSION-RELATED PART ON YOUR ENGINE IS DEFECTIVE, THE PART WILL BE REPAIRED OR REPLACED BY KOMATSU ZENOAH Co.

OWNER'S WARRANTY RESPONSIBILITIES:

—AS THE LAWN AND GARDEN EQUIPMENT ENGINE OWNER, YOU ARE RESPONSIBLE FOR THE PERFORMANCE OF THE **REQUIRED MAINTENANCE LISTED IN YOUR OWNER'S MANUAL**. KOMATSU ZENOAH Co. RECOMMENDS THAT YOU RETAIN ALL RECEIPTS COVERING MAINTENANCE ON YOUR LAWN AND GARDEN ENGINE, BUT KOMATSU ZENOAH Co. CAN NOT DENY WARRANTY SOLELY FOR THE LACK OF RECEIPTS OR FOR YOUR FAILURE TO ENSURE THE PERFORMANCE OF ALL SCHEDULED MAINTENANCE.

—AS THE LAWN AND GARDEN EQUIPMENT ENGINE OWNER, YOU SHOULD BE AWARE, HOWEVER, THAT KOMATSU ZENOAH Co. MAY DENY YOU WARRANTY COVERAGE IF YOUR LAWN AND GARDEN EQUIPMENT ENGINE OR A PART HAS FAILED DUE TO ABUSE, NEGLIGENCE, IMPROPER MAINTENANCE OR UNAPPROVED MODIFICATION.

—YOU ARE RESPONSIBLE FOR PRESENTING YOUR LAWN AND GARDEN EQUIPMENT ENGINE TO A KOMATSU ZENOAH Co. DISTRIBUTION CENTER AS SOON AS A PROBLEM EXISTS. THE WARRANTY REPAIRS SHOULD BE COMPLETED IN A REASONABLE AMOUNT OF TIME, NOT TO EXCEED **30 DAYS**.

IF YOU HAVE ANY QUESTIONS REGARDING YOU WARRANTY RIGHTS AND RESPONSIBILITIES, YOU SHOULD CONTACT KOMATSU ZENOAH AMERICA INC. AT (770)-381-5147.

**RedMax CHAINSAW
MODEL G310TS
1-YEAR LIMITED WARRANTY**

EMISSION-RELATED PARTS, FOR TWO (2) YEARS FROM THE DATE OF ORIGINAL DELIVERY OF THE MODEL G310TS UNIT, KOMATSU ZENOAH AMERICA INC. (THE COMPANY), THROUGH ANY RedMax DEALER, WILL REPAIR OR REPLACE, FREE OF CHARGE, FOR THE ORIGINAL AND EACH SUBSEQUENT PURCHASER, ANY PART OR PARTS FOUND TO BE DEFECTIVE IN MATERIAL AND/OR WORKMANSHIP. EMISSION-RELATED PARTS ARE:

**THE CARBURETOR ASSY, COIL ASSY, ROTOR, SPARKPLUG,
AIR FILTER, FUEL FILTER, INTAKE MANIFOLD, AND THE GASKETS**

ALL OTHER PARTS EXCEPT ABOVE PARTS, FOR ONE (1) YEAR OF HOME USE [NINETY (90) DAYS FOR ANY OTHER USE] FROM THE DATE OF ORIGINAL ANY DELIVERY OF THE MODEL G310TS UNIT, THE COMPANY, THROUGH ANY RedMax DEALER, WILL REPAIR OR REPLACE, FREE OF CHARGE, FOR THE ORIGINAL PURCHASER, ANY PART OF PARTS FOUND TO BE DEFECTIVE IN MATERIAL AND/OR WORKMANSHIP. **THIS IS THE EXCLUSIVE REMEDY.**

THE PURCHASER SHALL BEAR COSTS OF TRANSPORTING THE UNIT TO AND FROM THE RedMax DEALER.

THE PURCHASER SHALL NOT BE CHARGED FOR DIAGNOSTIC LABOR WHICH LEADS TO THE DETERMINATION THAT A WARRANTED PART IS DEFECTIVE, IF THE DIAGNOSTIC WORK IS PERFORMED AT THE RedMax DEALER.

THE PURCHASER OR OWNER IS RESPONSIBLE FOR THE PERFORMANCE OF THE REQUIRED MAINTENANCE AS DEFINED BY THE MANUFACTURER IN THE OWNER/OPERATOR MANUAL.

ANY WARRANTED PART WHICH IS NOT SCHEDULED FOR REPLACEMENT AS REQUIRED MAINTENANCE, OR WHICH IS SCHEDULED ONLY FOR REGULAR INSPECTION TO THE EFFECT OF "REPAIR OR REPLACE AS NECESSARY" SHALL BE WARRANTED FOR THE WARRANTY PERIOD. ANY WARRANTED PART WHICH IS SCHEDULED FOR REPLACEMENT AS REQUIRED MAINTENANCE SHALL BE WARRANTED FOR THE PERIOD OF TIME UP TO THE FIRST SCHEDULED REPLACEMENT POINT FOR THE PART.

ANY REPLACEMENT PART THAT IS EQUIVALENT IN PERFORMANCE AND DURABILITY MAY BE USED IN NON-WARRANTY MAINTENANCE OR REPAIRS, AND SHALL NOT REDUCE THE WARRANTY OBLIGATION OF THE COMPANY.

THE COMPANY IS LIABLE FOR DAMAGES TO OTHER ENGINE COMPONENTS CAUSED BY THE FAILURE OF A WARRANTED PARTS STILL UNDER WARRANTY.

THE WARRANTY DOES NOT APPLY TO THOSE UNITS WHICH HAVE BEEN DAMAGED BY NEGLIGENCE OF INSTRUCTION LISTED IN THE OWNER/OPERATOR MANUAL FOR PROPER USE AND MAINTENANCE OF THE UNITS, ACCIDENT MISHANDLING, ALTERATION, ABUSE, IMPROPER LUBRICATION, USE OF ANY PARTS OR ACCESSORIES OTHER THAN THOSE SPECIFIED BY THE COMPANY, OR OTHER CAUSES BEYOND THE COMPANY'S CONTROL.

THIS WARRANTY DOES NOT COVER THOSE PARTS REPLACED BY NORMAL WEAR OR HARMLESS CHANGES IN THEIR APPEARANCE.

THERE ARE NO OTHER EXPRESS WARRANTIES.

IMPLIED WARRANTIES INCLUDING THOSE OF MERCHANTABILITY AND FITNESS FOR A PARTICULAR PURPOSE **ARE LIMITED** TO ONE (1) YEAR OF HOME USE [NINETY (90) DAYS FOR ANY OTHER USE] FROM THE ORIGINAL DELIVERY DATE.

LIABILITIES FOR INCIDENTAL OR CONSEQUENTIAL DAMAGE UNDER ANY AND ALL WARRANTIES ARE EXCLUDED.

SOME STATES DO NOT ALLOW LIMITATION ON HOW LONG AN IMPLIED WARRANTY LASTS OR EXCLUSION OR LIMITATION OF INCIDENTAL OR CONSEQUENTIAL DAMAGES, SO THE ABOVE LIMITATION OR EXCLUSION MAY NOT APPLY TO YOU.

THIS WARRANTY GIVES YOU SPECIFIC LEGAL RIGHTS, AND YOU MAY ALSO HAVE OTHER RIGHTS WHICH VARY FROM STATE TO STATE.

IF YOU NEED TO OBTAIN INFORMATION ABOUT THE NEAREST SERVICE CENTER, PLEASE CALL KOMATSU ZENOAH AMERICA INC. AT (770)-381-5147.

IMPORTANT: YOU WILL RECEIVE A WARRANTY REGISTRATION CARD AT TIME OF PURCHASE. PLEASE FILL OUT THE CARD AND SEND IT TO RedMax / KOMATSU ZENOAH AMERICA WITHIN SEVEN (7) DAYS. BE SURE TO KEEP A COPY FOR YOUR RECORDS.



RedMax[®]

KOMATSU ZENOAH AMERICA INC.
4344 Shackelford Road Suite 500
Norcross, Georgia 30093

RedMax CHAINSAW
Modèle G310TS
Garantie limitée à 1 ans

Pièces en rapport avec les émissions de gaz d'échappement : KOMATSU ZENOAH AMERICA INC., par l'intermédiaire de n'importe quel revendeur RedMax, réparera gratuitement ou remplacera gratuitement pour l'acheteur initial et chaque acheteur successif toute(s) pièce(s) se révélant de constitution et/ou de montage défectueux pendant deux (2) ans à compter de la date initiale de livraison d'une unité du modèle G310TS. Les pièces en rapport avec les émissions de gaz d'échappement sont:

**l'assemblage carburateur, l'assemblage bobine, le rotor, la bougie,
le filtre à air, le filtre à carburant, la tubulure d'admission et les joints**

Toutes autres pièces exceptées celles mentionnées ci-dessus : La société, par l'intermédiaire de n'importe quel revendeur RedMax, réparera gratuitement ou remplacera gratuitement pour l'acheteur initial toute(s) pièce (s) se révélant de constitution et/ou de montage défectueux pendant un (1) ans en cas d'utilisation privée [quatre-vingt-dix (90) jours pour toute autre utilisation] à compter de la date de livraison initiale d'une unité du modèle G310TS. **Telles sont les limites de la garantie.**

Le coût du transport de l'unité jusqu'au revendeur RedMax et depuis celui-ci sera à la charge de l'acheteur.

L'acheteur ne supportera pas le coût de main d'oeuvre du diagnostic qui amène à la conclusion qu'une pièce garantie est défectueuse, si ce diagnostic est effectué chez le revendeur RedMax.

L'acheteur ou propriétaire a pour responsabilité d'effectuer l'entretien obligatoire tel que défini par le fabricant dans le manuel du propriétaire/de l'utilisateur.

Toute pièce garantie dont le remplacement n'est pas prévu dans le cadre de l'entretien obligatoire, ou pour laquelle est seulement prévue une inspection périodique pour "remplacement ou réparation si nécessaire" sera garantie pour la période de garantie. Toute pièce garantie arrivée à l'échéance de son premier remplacement prévu sera garantie jusqu'à celui-ci.

Toute pièce de rechange équivalente en performance ou en durabilité peut être utilisée pour l'entretien hors-garantie ou les réparations hors-garantie, et ce sans réduire l'obligation de garantie incombant à la société.

La société sera tenue responsable des dommages aux autres composants du moteur causés par la défaillance de pièce(s) garantie(s) en période de garantie.

La garantie ne s'applique pas aux unités endommagées par suite de: négligence dans la mise en oeuvre des instructions spécifiées dans le manuel du propriétaire/de l'utilisateur en vue d'une utilisation et d'un entretien correct, fausse manœuvre accidentelle, modification, utilisation abusive, lubrification incorrecte, utilisation de pièces ou d'accessoires autres que ceux spécifiés par la société, ou autres causes hors du contrôle de la société.

Cette garantie ne couvre pas les pièces remplacées en raison de leur usure normale ou de changements d'apparence sans effets.

Il n'existe aucune autre garantie explicite.

Les garanties implicites, celles de négociabilité du produit et de son adaptabilité à un usage défini incluses, **sont limitées** à un (1) ans pour un usage privé [quatre-vingt-dix (90) jours pour toute autre utilisation] à compter de la date initiale de livraison.

Les responsabilités pour les dommages conséquents ou incidents sont exclues de toutes les garanties.

Certaines provinces n'autorisant pas les limitations à la durée des garanties implicites, ou les exclusions ou limitations relatives aux dommages incidents ou conséquents, la limitation indiquée ci-dessus peut ne pas vous être applicable.

Cette garantie vous donne des droits juridiques spécifiques, et vous pouvez également jouir d'autres droits variant d'une province à l'autre.

Si vous désirez obtenir des informations sur le centre de service le plus proche, veuillez appeler KOMATSU ZENOAH AMERICA INC. au (770)-381-5147

Note importante: vous recevrez une carte d'enregistrement de garantie au moment de l'achat. Veuillez la remplir et l'adresser à RedMax / KOMATSU ZENOAH AMERICA sous sept (7) jours en prenant soin de conserver une copie pour vous.



KOMATSU ZENOAH AMERICA INC.
4344 Shackelford Road Suite 500
Norcross, Georgia 30093

Free Manuals Download Website

<http://myh66.com>

<http://usermanuals.us>

<http://www.somanuals.com>

<http://www.4manuals.cc>

<http://www.manual-lib.com>

<http://www.404manual.com>

<http://www.luxmanual.com>

<http://aubethermostatmanual.com>

Golf course search by state

<http://golfingnear.com>

Email search by domain

<http://emailbydomain.com>

Auto manuals search

<http://auto.somanuals.com>

TV manuals search

<http://tv.somanuals.com>