

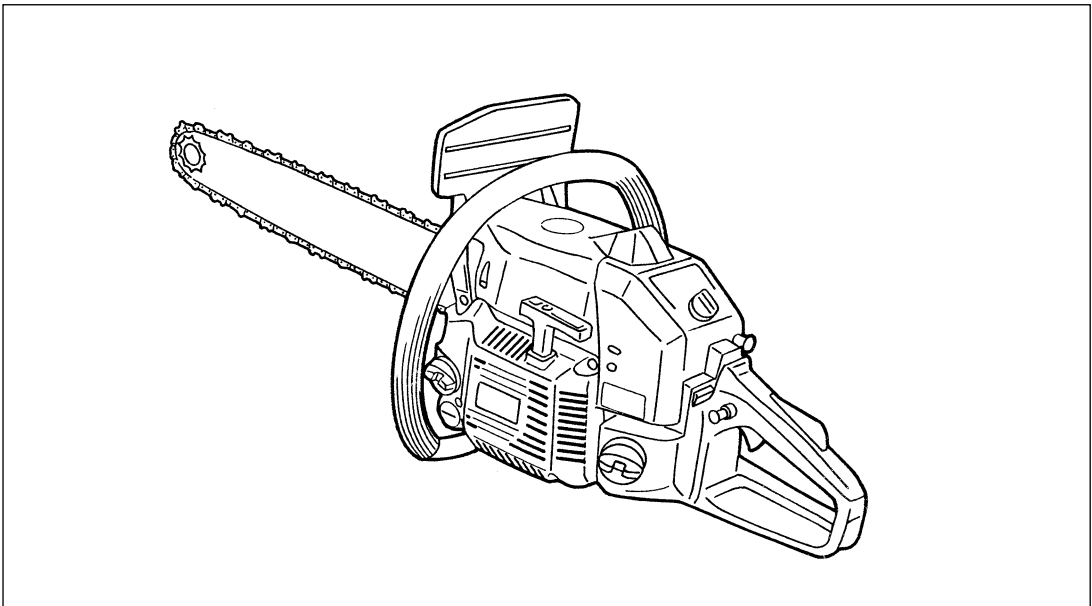

OWNER/OPERATOR MANUAL

CHAINSAWS

G621AVS



WARNING



The engine exhaust from this product contains chemicals known to the State of California to cause cancer, birth defects or other reproductive harm.



WARNING



Before using our products, please read this manual carefully to understand the proper use of your unit.

APPLICABLE SERIAL NUMBERS :

330138 and up



SAFETY FIRST

Instructions contained in warnings within this manual marked with a  symbol concern critical points which must be taken into consideration to prevent possible serious bodily injury, and for this reason you are requested to read all such instructions carefully and follow them without fail.

■ **WARNINGS IN THE MANUAL**



This mark indicates instructions which must be followed in order to prevent accidents which could lead to serious bodily injury or death.



This mark indicates instructions which must be followed, or it leads to mechanical failure, breakdown, or damage.



This mark indicates hints or directions useful in the use of the product.

CONTENTS

1. Parts location	3
2. Specifications	3
3. Symbols on the machine	4
4. For safe operation	5
5. Installing guide bar and saw chain	7
6. Fuel and chain oil	8
7. Operation	10
8. Sawing	14
9. Maintenance	17
10. Maintenance of Saw Chain and Guide Bar	20
11. Storage	21
12. Troubleshooting Guide	22
13. Parts list	23

1. Parts location

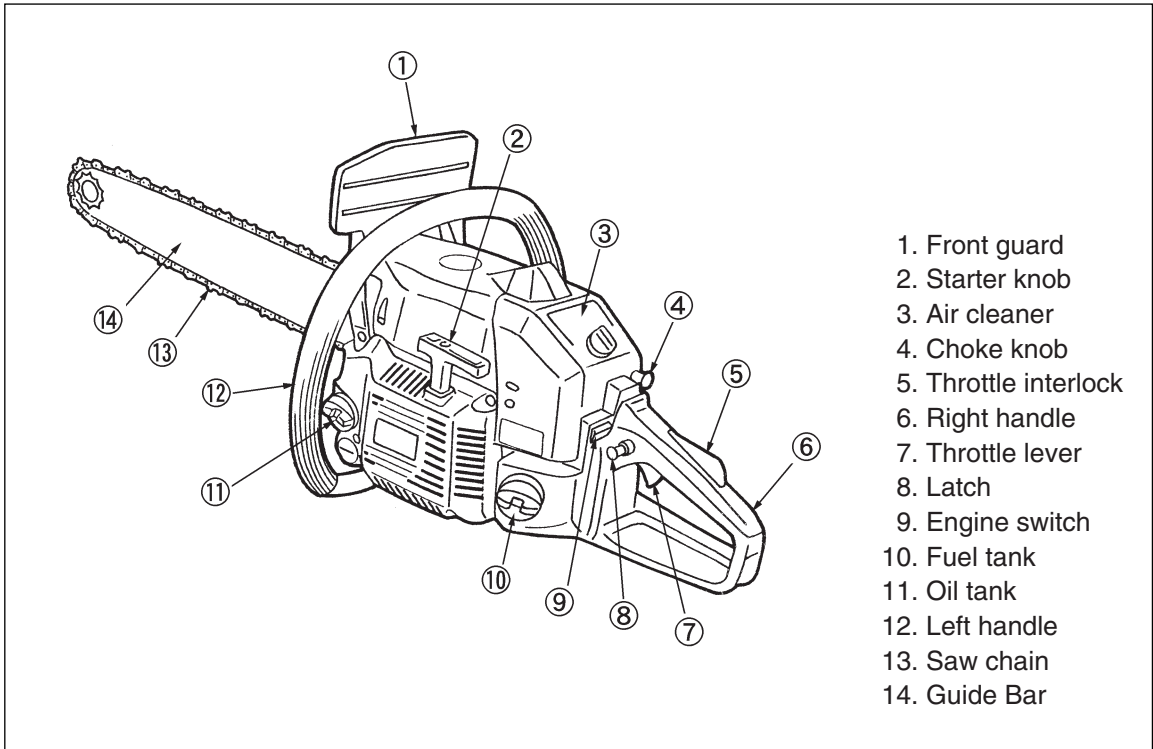

1. Front guard
2. Starter knob
3. Air cleaner
4. Choke knob
5. Throttle interlock
6. Right handle
7. Throttle lever
8. Latch
9. Engine switch
10. Fuel tank
11. Oil tank
12. Left handle
13. Saw chain
14. Guide Bar

2. Specifications

■ G621AVS

Power unit :

Displacement	3.78(62.0) cu-in(cm ³)
Fuel	Mixture(Gasoline 50 : 2-cycle oil 1)
Fuel tank capacity	22.4(0.67) fl.oz(ℓ)
Chain oil	Motor oil SAE #10W-30
Oil tank capacity	11.8(0.35) fl.oz(ℓ)
Carburetor	Diaphragm type (Walbro HDA)
Ignition system	Solid-state
Spark plug	Champion CJ-7Y
Oil feeding system	Variable delivery type
Sprocket : Pitch – No. of teeth	3/8in(9.53mm) – 7T
Dimensions : L – W – H	17.3(433)x10.2(255)x11.4(285) in(mm)
Dry weight	11.9(5.3) lbs(kg)

Cutting attachment :

Guide bar : Type – Size	18(45), 20(50), 24(60) in(cm)
Saw chain : Type – Pitch – Gauge	Oregon 72V – 3/8(9.53) – 0.050(1.27) in(mm)

Specifications are subject to change without notice.

3. Symbols on the machine

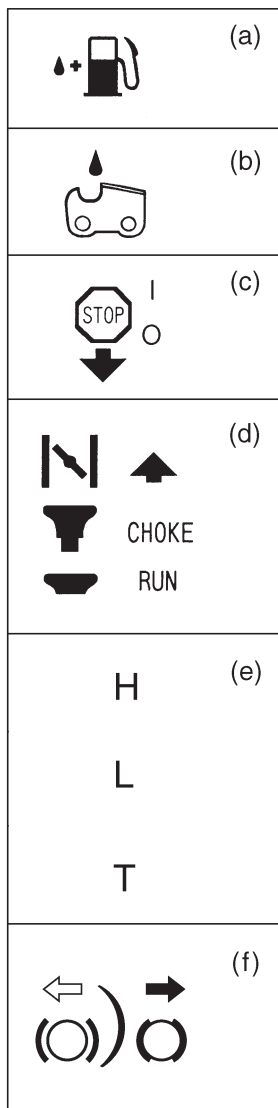

⚠ WARNING

For safe operation and maintenance, symbols are carved in relief on the machine.

According to these indications, please be careful not to take a mistake.

(a). The port to refuel the "MIX GASOLINE"

Position: Fuel cap

(b). The port to refuel the chain oil

Position: Oil cap

(c). Put the switch to the "O" position, immediately the engine stops.

Position: Rear-left of the unit

(d). Starting the engine, if you pull out the choke knob (at the back-right of the rear handle) to the point of the arrow, you can set the starting mode as follows

- First-stage position – starting mode when the engine is warm.
- Second-stage position – starting mode when the engine is cool.

Position: Upper-right of the aircleaner cover

(e). The screw under the "H" stamp is The High-speed adjustment screw.

The screw under the "L" stamp is The Slow-speed adjustment screw.

The screw at the left of the "T" stamp is the Idle adjustment screw.

Position: Left side of the rear handle

(f). It shows the directions that the chain brake is released (for the white arrow) and activated (for the black arrow).

Position: Front of the chain cover

IMPORTANT ENGINE INFORMATION

THIS ENGINE CONFORMS TO US EPA PH1 FOR SMALL OFF-ROAD ENGINES.

ENGINE FAMILY : 5KZXS. 0625MN:EM

ENGINE DISPLACEMENT : 62cc

REFER TO OWNER'S MANUAL FOR MAINTENANCE SPECIFICATIONS AND ADJUSTMENTS.

MANUFACTURED :

ZENOAH KOMATSU ZENOAH CO.
RedMax Made in Japan

INFORMATION IMPORTANTE CONCERNANT LE MOTEUR

Ce moteur conformc aux normcs U.S. EPA PH1 pour les petits moteurs tout-terrain.

Type de moteur : 5KZXS. 0625MN:EM

Cylindrée du moteur : 62cc

Se référer au Manuel de l'utilisateur pour les spécifications d'entretien et les réglages.

Manufacturé :

ZENOAH KOMATSU ZENOAH CO.
RedMax Made in Japan



4. For safe operation

1. Never operate a chain saw when you are fatigued, ill, or upset, or under the influence of medication that may make you drowsy, or if you are under the influence of alcohol or drugs.
2. Use safety footwear, snug fitting clothing and eye, hearing and head protection devices.
3. Always use caution when handling fuel. Wipe up all spills and then move the chain saw at least ten(10) feet(three(3) m) from the fueling point before starting the engine.
 - 3a) Eliminate all sources of sparks or flame (ie. smoking, open flames, or work that can cause sparks) in the areas where fuel is mixed, poured, or stored.
 - 3b) Do not smoke while handling fuel or while operating the chain saw.
4. Do not allow other persons to be near the chain saw when starting the engine or cutting a wood. Keep bystanders and animals out of the work area. Children, pets, and bystanders should be a minimum of thirty(30) feet away when you start or operate the chain saw.
5. Never start cutting until you have a clear work area, secure footing, and planned retreat path from the falling tree.
6. Always hold the chain saw firmly with both hands when the engine is running. Use a firm grip with thumb and fingers encircling the chain saw handles.
7. Keep all parts of your body away from the saw chain when the engine is running.
8. Before you start the engine, make sure the saw chain is not contacting anything.
9. Always carry the chain saw with the engine stopped, the guide bar and saw chain to the rear, and the muffler away from your body.
10. Always inspect the chain saw before each use for worn, loose, or changed parts. Never operate a chain saw that is damaged, improperly adjusted, or is not completely and securely assembled. Be sure that the saw chain stops moving when the throttle control trigger is released.
11. All chain saw service, other than the items listed in the Operator's Manual, should be performed by competent chain saw service personnel. (e.g., if improper tools are used to remove the flywheel, or if an improper tool is used to hold the flywheel in order to remove the clutch, structural damage to the flywheel could occur which could subsequently cause the flywheel to disintegrate).
12. Always shut off the engine before setting it down.
13. Use extreme caution when cutting small size brush and saplings because slender material may catch the saw chain and be whipped toward you or pull you off balance.
14. When cutting a limb that is under tension, be alert for spring back so that you will not be struck when the tension in the wood fibers is released.
15. Keep the handles dry, clean and free of oil or fuel mixture.



4. For safe operation

16. Operate the chain saw only in well ventilated areas. Never start or run the engine inside a closed room or building. Exhaust fumes contain dangerous carbon monoxide.
17. Do not operate a chain saw in a tree unless specially trained to do so.
18. Guard against kickback. Kickback is the upward motion of the guide bar which occurs when the saw chain at the nose of the guide bar contacts an object. Kickback can lead to dangerous loss of control of the chain saw.
19. When transporting your chain saw, make sure the appropriate guide bar scabbard is in place.
20. This chain saw is equipped with a spark arrester built-in muffler. Periodically check the arrester to keep it in good order.

KICKBACK SAFETY PRECAUTIONS FOR CHAIN SAW USERS

⚠ WARNING

- Kickback may occur when the nose or tip of the guide bar touches an object, or when the wood closes in and pinches the saw chain in the cut. Tip contact in some cases may cause a lightning fast reverse reaction, kicking the guide bar up and back towards the operator. Pinching the saw chain along the top of the guide bar may push the guide bar rapidly back towards the operator. Either of these reactions may cause you to lose control of the saw which could result in serious personal injury.
- Do not rely exclusively on the safety devices built into your saw. As a chain saw user you should take several steps to keep cutting jobs free from accident or injury.
 - (1) With a basic understanding of kickback you can reduce or eliminate the element of surprise. Sudden surprise contributes to accidents.
 - (2) Keep a good grip on the saw with both hands, the right hand on the rear handle, and the left hand on the front handle, when the engine is running. Use a firm grip with thumbs and fingers encircling the chain saw handles. A firm grip will help you reduce kickback and maintain control of the saw. Don't let go.
 - (3) Make certain that the area in which you're cutting is free from obstructions. Do not let the nose of the guide bar contact a log, branch, or any other obstruction which could be hit while you are operating the saw.
 - (4) Cut at high engine speeds.
 - (5) Do not overreach or cut above shoulder height.
 - (6) Follow manufacturers sharpening and maintenance instructions for saw chain.
 - (7) Only use replacement bars and chains specified by the manufacturer or the equivalent.

5. Installing guide bar and saw chain

WARNING

The saw chain has very sharp edges. Use thick protective gloves for safety.

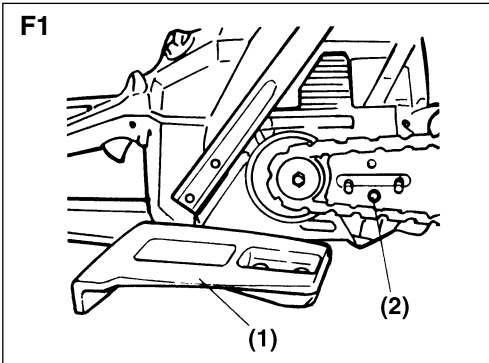

1. Loosen the nuts and remove the chain cover. (F1)
2. Install the attached spike to the power unit.
3. Fit the saw chain around the guide bar and, while gearing the chain to the sprocket, mount the guide bar to the power unit. Then fit the chain tensioner nut into the lower hole of the guide bar. (F1)

- (1) Chain cover
(2) Chain tensioner nut

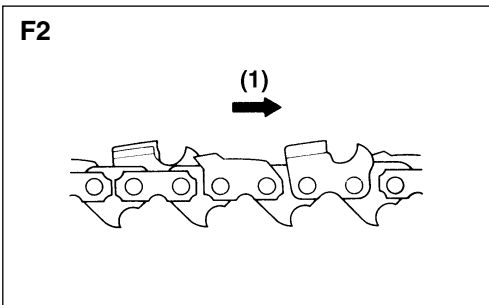

NOTE

Pay attention to the correct direction of the saw chain. (F2)

(1) Moving Direction

4. Fit the chain cover to the power unit and fasten the nuts to finger tightness.
5. While holding up the tip of the bar, adjust the chain tension by turning the tensioner screw until the tie straps just touch the bottom side of the bar rail.
6. Tighten the nuts securely with the bar tip held up (12~15 N·m). Then check the chain for smooth rotation and proper tension while moving it by hand. If necessary, readjust with the chain cover loose.
7. Tighten the tensioner screw. (F3)

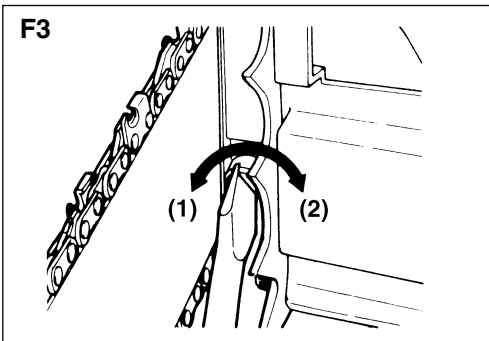

- (1) Loosen
(2) Tighten

NOTE

A new chain will expand its length in the beginning of use. Check and readjust the tension frequently as a loose chain can easily derail or cause rapid wear of itself and the guide bar.

6. Fuel and Chain oil

⚠ WARNING

- Gasoline is very flammable. Avoid smoking or bringing any flame or sparks near fuel. Make sure to stop the engine and allow it cool before refueling the unit. Select outdoor bare ground for fueling and move at least 3m (10ft) away from the fueling point before starting the engine.



- The RedMax engines are lubricated by oil specially formulated for air-cooled 2-cycle gasoline engine use. If RedMax oil is not available, use an anti-oxidant added quality oil expressly labeled for air-cooled 2-cycle engine use. (JASO FC GRADE OIL or ISO EGC GRADE)
- Do not use BIA or TCW (2-stroke water-cooling type) mixed oil.

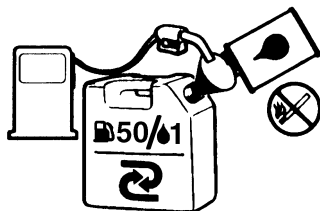

■ RECOMMENDED MIXING RATIO GASOLINE 50:OIL 1

50:1 MIXING CHART

GASOLINE gal.	1	2	3	4	5
2-CYCLE OIL fl.oz	2.6	5.2	7.8	10.4	13

GASOLINE liter	1	2	3	4	5
2-CYCLE OIL ml	20	40	60	80	100

- Exhaust emission are controlled by the fundamental engine parameters and components (eq., carburation, ignition timing and port timing) without addition of any major hardware or the introduction of an inert material during combustion.
- These engines are certified to operate on unleaded gasoline.
- Make sure to use gasoline with a minimum octane number of 89 RON (USA/Canada: 87AL)
- If you use a gasoline of a lower octane value than prescribed, there is a danger that the engine temperature may rise and an engine problem such as piston seizing may consequently occur.
- Unleaded gasoline is recommended to reduce the contamination of the air for the sake of your health and the environment.
- Poor quality gasolines or oils may damage sealing rings, fuel lines or fuel tank of the engine.

■ HOW TO MIX FUEL

⚠ IMPORTANT

Pay attention to agitation.

- Measure out the quantities of gasoline and oil to be mixed.
- Put some of the gasoline into a clean, approved fuel container.
- Pour in all of the oil and agitate well.
- Pour In the rest of gasoline and agitate

6. Fuel and Chain oil

again for at least one minute. As some oils may be difficult to agitate depending on oil ingredients, sufficient agitation is necessary for the engine to last long. Be careful that, if the agitation is insufficient, there is an increased danger of early piston seizing due to abnormally lean mixture.

5. Put a clear indication on the outside of the container to avoid mixing up with gasoline or other containers.
6. Indicate the contents on outside of container for easy identification.

■ FUELING THE UNIT

1. Untwist and remove the fuel cap. Rest the cap on a dustless place.
2. Put fuel into the fuel tank to 80% of the full capacity.
3. Fasten the fuel cap securely and wipe up any fuel spillage around the unit.

▲ WARNING

1. Select bare ground for fueling.
2. Move at least 10feet (3meters) away from the fueling point before starting the engine.
3. Stop the engine before refueling the unit. At that time, be sure to sufficiently agitate the mixed gasoline in the container.

FOR YOUR ENGINE LIFE, AVOID;

1. FUEL WITH NO OIL(RAW GASOLINE) – It will cause severe damage to the internal engine parts very quickly.
2. GASOHOL – It can cause deterioration of rubber and/or plastic parts and disruption of engine lubrication.
3. OIL FOR 4-CYCLE ENGINE USE – It can cause spark plug fouling, exhaust port blocking, or piston ring sticking.
4. **Mixed fuels which have been left unused for a period of one month or more** may clog the carburetor and result in the engine failing to operate properly.
5. In the case of storing the product for a

long period of time, clean the fuel tank after rendering it empty. Next, activate the engine and empty the carburetor of the composite fuel.

6. In the case of scrapping the used mixed oil container, scrap it only at an authorized repository site.

NOTE

As lot details of quality assurance, read the description in the section Limited Warranty carefully. Moreover, normal wear and change in product with no functional influence are not covered by the warranty. Also, be careful that, if the usage in the instruction manual is not observed as to the mixed gasoline, etc. described therein, it may not be covered by the warranty.

■ CHAIN OIL

Use motor oil SAE 10W-30 all year round, or SAE 30-40 in summer and SAE 20 in winter.

NOTE

Do not use waste or regenerated oil that can cause damage to the oil pump.

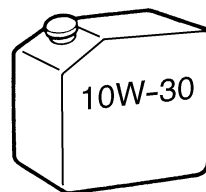

7. Operation

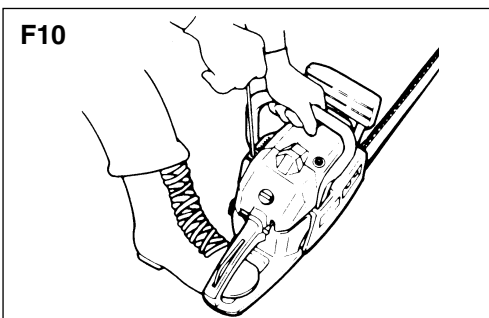
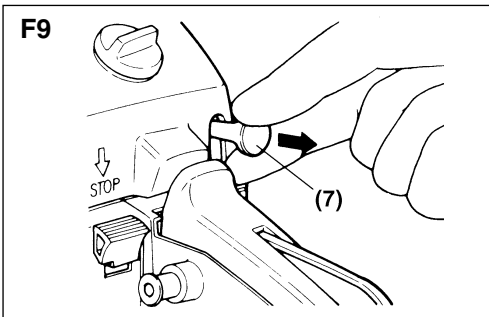
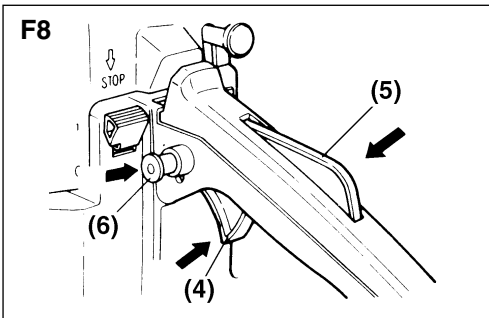
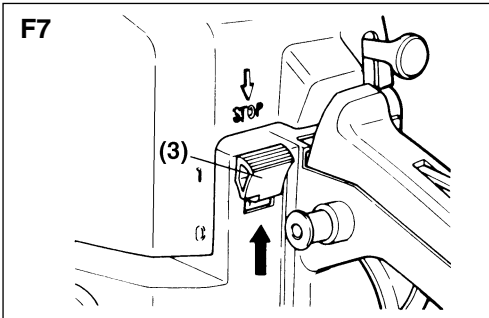
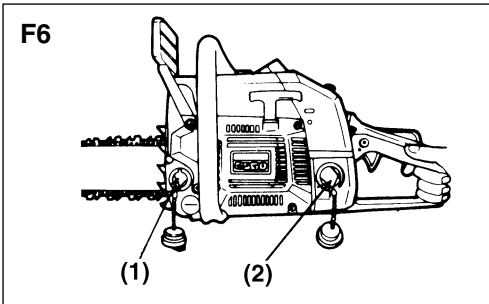

⚠ WARNING

It is very dangerous to run a chainsaw that mounts broken parts or lacks any parts. Before starting engine, make sure that all the parts including bar and chain are installed properly.

■ STARTING ENGINE

1. Fill fuel and chain oil tanks respectively, and tighten the caps securely. (F6)
2. Put the switch to "I" position. (F7)
3. While holding the throttle lever together with the throttle interlock, push in the side latch and release the throttle lever to hold it at the starting position. (F8)
4. Pull out the choke knob to the closed position. (F9)

- | | |
|------------------------|--------------------|
| (1) Chain oil | (2) Fuel |
| (3) Switch | (4) Throttle lever |
| (5) Throttle interlock | (6) Latch |
| (7) Choke knob | |

📖 NOTE

When restarting immediately after stopping the engine, leave the choke knob at the open position.

5. While holding the saw unit securely on the ground, pull the starter rope vigorously. (F10)

⚠ WARNING

Do not start the engine while hanging the chain saw with a hand. The saw chain may touch your body. It's very dangerous.

6. When engine has ignited first, push in the choke knob and pull the starter again to start the engine.
7. Allow the engine to warm up with the throttle lever pulled slightly.

⚠ WARNING

Keep clear of the saw chain as it will start rotating upon starting of engine.

7. Operation

■ CHECKING OIL SUPPLY

WARNING

Make sure to set up the bar and the chain when checking the oil supply. If not, the rotating parts may be exposed. It is very dangerous.

After starting the engine, run the chain at medium speed and see if chain oil is scattered off as shown in the figure. (F11)

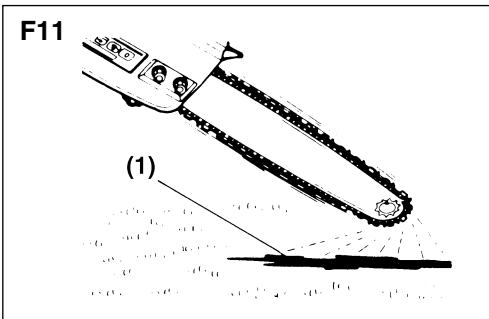

(1) Chain oil

The oil flow can be changed by turning the adjuster knob on the top of the cylinder cover. Adjustment according to your work conditions. (F12)

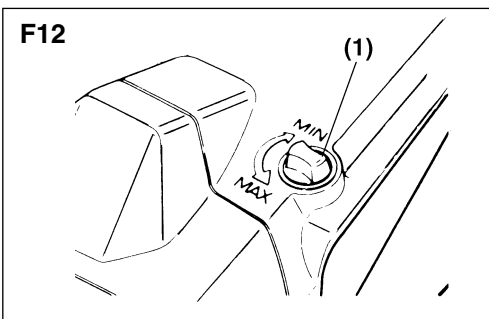

(1) Adjuster knob

NOTE

The oil tank should become nearly empty by the time fuel is used up. Be sure to refill the oil tank every time when refueling the saw.

■ ADJUSTING CARBURETOR (F13)

The carburetor on your unit has been factory adjusted, but may require fine tuning due to change in operating conditions.

Before adjusting the carburetor, make sure that provided are clean air/fuel filters and fresh, properly mixed fuel.

When adjusting, take the following steps:

NOTE

Be sure to adjust the carburetor with the bar chain attached.

1. H and L needles are restricted within the number of turn as shown below.

H needle -1/4

L needle -1/4

2. Start engine and allow it to warm up in low speed for a few minutes.

3. Turn idle adjusting screw (T) counter-clockwise

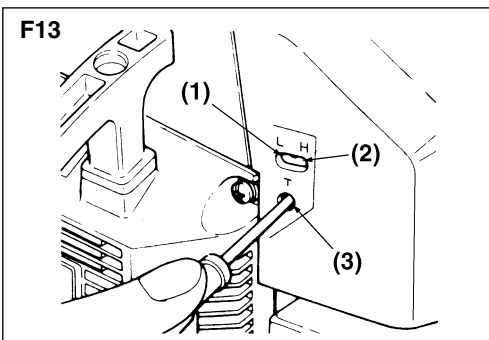

7. Operation

so that saw chain does not turn. If idling speed is too slow, turn the screw clockwise.

4. Make a test cut adjust the H needle for best cutting power, not for maximum speed.

- (1) L needle
- (2) H needle
- (3) Idle adjusting screw

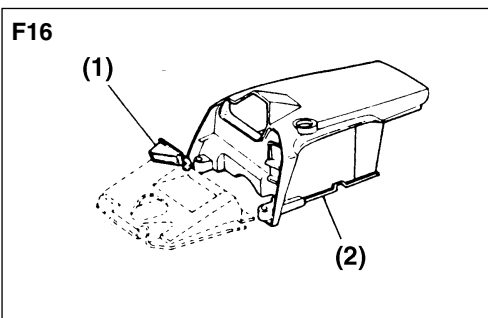
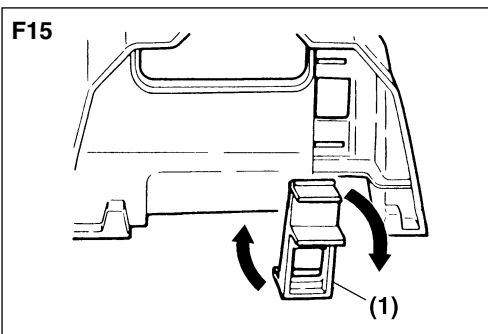
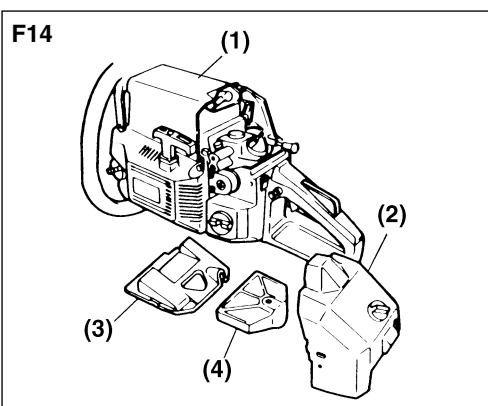

■ ICING PREVENTION SYSTEM

This system prevents icing of the carburetor which sometimes happen while sawing in winter.

When your saw is possible to be frozen at the carburetor during operation, use the system as follows:

1. Remove the air cleaner cover, air filter, and silencer. (F14)

- (1) Cylinder cover
- (2) Air cleaner cover
- (3) Intake silencer
- (4) Air filter

2. Pull off the plug on the rear wall of the cylinder cover and reinstall it upside down. (F15)

- (1) Plug

3. Install the covers as they are.

⚠ IMPORTANT

Never use the system in normal temperature because that can cause starting failure due to overheating of the carburetor.

■ ANTI-FREEZE PARTS

For use under extra cold condition. Optional parts as shown right are available. When normal air filter is frozen even with the plug opened, contact your nearest dealer for the anti-freeze parts. (F16)

- (1) Air inlet plug (P/N 2610-83220)
- (2) Cylinder cover for cold use (P/N 2626-31110)

7. Operation

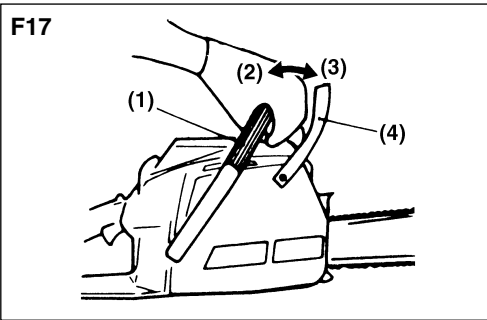

■ CHAIN BRAKE

This machine is equipped with an automatic brake to stop saw chain rotation upon occurrence of kickback while in saw cutting operation. The brake is automatically operated by inertial force which acts on the weight fitted inside the front guard.

This brake can also be operated manually with the front guard turned down to the guide bar.

To release brake, pull up the front guard toward the front handle till "click" sound is heard. (F17)

(1) Front handle

(2) Released

(3) Braking

(4) Brake lever

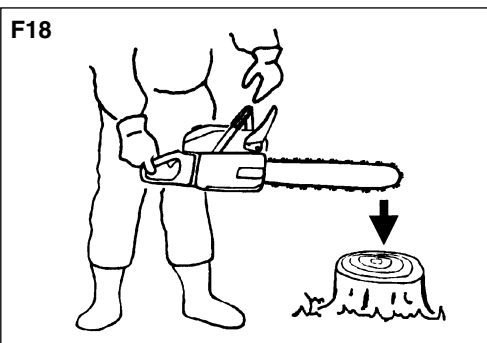

❗ IMPORTANT

Be sure to confirm brake operation on the daily inspection.

How to confirm:

- 1) Turn off the engine.
- 2) Holding the chain saw horizontally, release your hand from the front handle, hit the tip of the guide bar to a stump or a piece of wood, and confirm brake operation. Operating level varies by bar size. (F18)

In case the brake is not effective, ask our dealer inspection and repairing.

The engine, if being kept rotated at high speed with the brake engaged, heats the clutch, causing a trouble.

When the brake is operated while in operation, immediately release your fingers from the throttle lever and stop the engine.

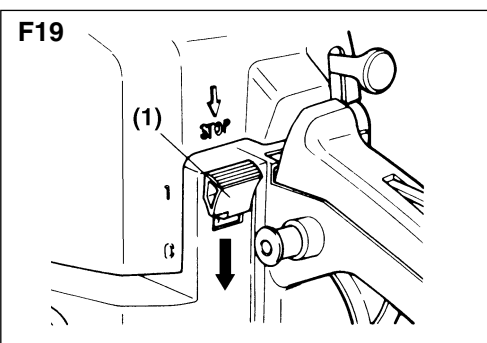

■ STOPPING ENGINE

1. Release the throttle lever to allow the engine idling for a few minutes
2. Put the switch to the "O" (STOP) position. (F19)

(1) Switch

8. Sawing

⚠ WARNING

- Before proceeding to your job, read "For Safe Operation" section It is recommended to first practice sawing easy logs. This also helps you get accustomed to your unit.
- Always follow the safety regulations. The chain saw must only be used for cutting wood. It is forbidden to cut other types of material. Vibrations and kickback vary with different materials and the requirements of the safety regulations would not be respected. Do not use the chain saw as a lever for lifting, moving or splitting objects. Do not lock it over fixed stands. It is forbidden to hitch tools or applications to the P.t.o. that are not specified by the manufacturer.
- It is not necessary to force the saw into the cut. Apply only light pressure while running the engine at full throttle.
- When the saw chain is caught in the cut, do not attempt to pull it out by force, but use a wedge or a lever to open the way.

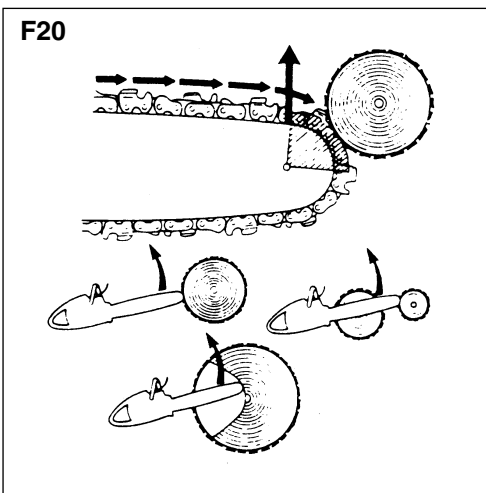

■ GUARD AGAINST KICKBACK (F20)

- This saw is equipped with a chain brake that will stop the chain in the event of kickback if operating properly. You must check the chain brake operation before each usage by running the saw at full the throttle for 1 -2 seconds and pushing the front hand guard forward. The chain should stop immediately with the engine at full speed. If the chain is slow to stop or does not stop, replace the brake band and clutch drum before use.
- It is extremely important that the chain brake be checked for proper operation before each use and that the chain be sharp in order to maintain the kickback safety level of this saw. Removal of the safety devices, inadequate maintenance, or incorrect replacement of the bar or chain may increase the risk of serious personal injury due to kickback.

8. Sawing

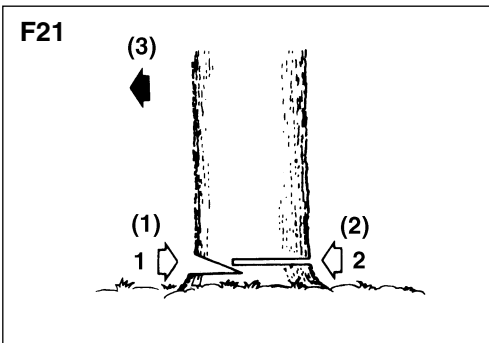

■ FELLING A TREE (F21)

1. Decide the felling direction considering the wind, lean of the tree, location of heavy branches, ease of job after felling and other factors.
2. While clearing the area around the tree, arrange a good foothold and retreat path.
3. Make a notch cut one-third of the way into the tree on the felling side.
4. Make a felling cut from the opposite side of the notch and at a level slightly higher than the bottom of the notch.

⚠ WARNING

When you fell a tree, be sure to warn your neighboring workers of the danger.

- (1) Notch cut
- (2) Felling cut
- (3) Felling direction

Bucking and Limbing

⚠ WARNING

- Always ensure your foothold. Do not stand on the log.
- Be alert to the rolling over of a cut log. Especially when working on a slope, stand on the uphill side of the log.
- Follow the instructions in "For Safe Operation" to avoid kickback of the saw.

Before starting work, check the direction of bending force inside the log to be cut. Always finish cutting from the opposite side of bending direction to prevent the guide bar from being caught in the cut.

8. Sawing

F22

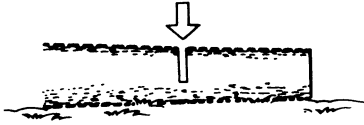

A Log lying on the ground (F22)

Saw down halfway, then roll the log over and cut from the opposite side.

F23

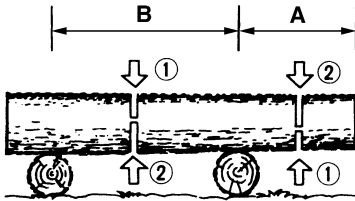

A Log hanging off the ground (F23)

In area A, saw up from the bottom one-third and finish by sawing down from the top. In area B, saw down from the top one-third and finish by sawing up from the bottom.

F24

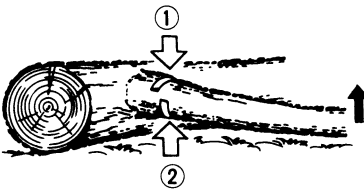

Cutting Limb of Fallen Tree (F24)

First check to which side the limb is bent. Then make the initial cut from the bent side and finish by sawing from the opposite side.

⚠ WARNING

Be alert to the springing back of a cut limb.

F25

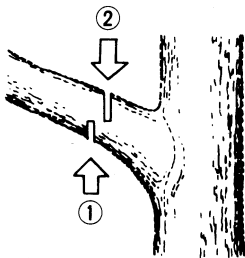

Pruning of Standing Tree (F25)

Cut up from the bottom, finish down from the top.

⚠ WARNING

- Do not use an unstable foothold or ladder.
- Do not overreach.
- Do not cut above shoulder height.
- Always use your both hands to grip the saw.

9. Maintenance

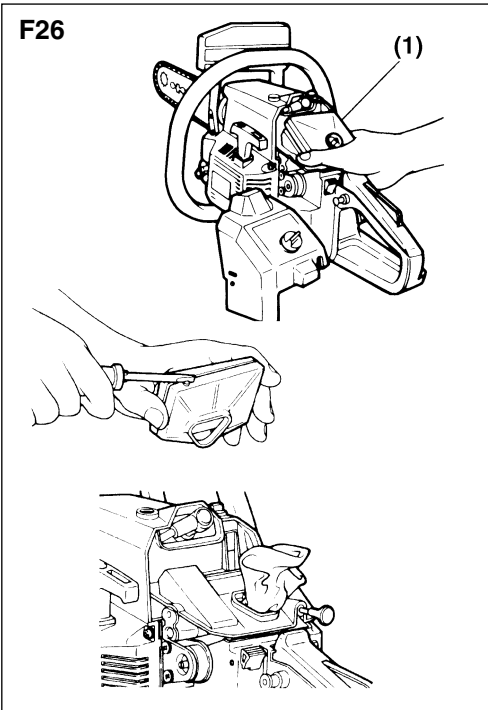

Maintenance, replacement, or repair of the emission control device and systems may be performed by any non-road engine repair establishment or individual.

⚠ WARNING

Before cleaning, inspecting or repairing your unit, make sure that engine has stopped and is cool. Disconnect the spark plug to prevent accidental starting.

■ MAINTENANCE AFTER EACH USE

1. Air filter

Loosen the knob and remove the air cleaner cover. Take off the filter element and brush off attached sawdust. When the filter is clogged with dust, separate it in halves and shake-wash with gasoline. Dry them completely before reinstalling. (F26)

(1) Air filter

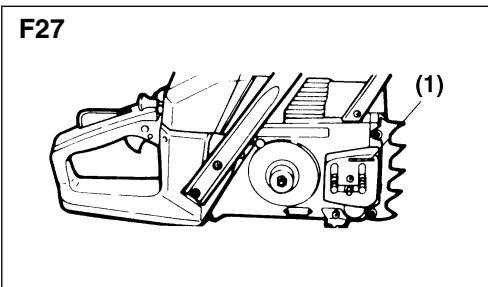

📖 NOTE

When servicing the air filter, be sure to block the air intake hole with cloth. (F26)

2. Oiling port

Dismount the guide bar and check the oiling port for clogging. (F27)

(1) Oiling port

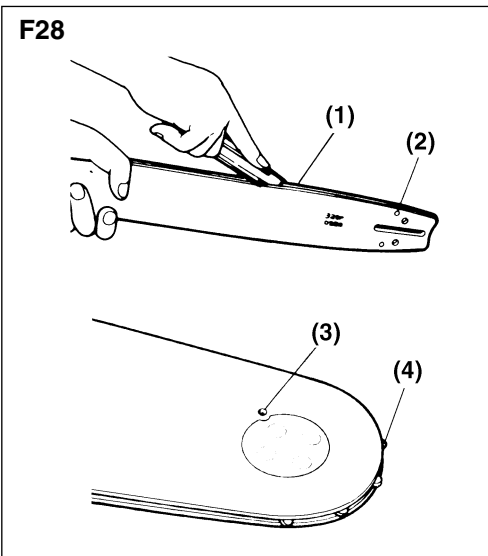

3. Guide bar

When the guide bar is dismantled, remove sawdust in the bar groove and the oiling port. (F29) Grease the nose sprocket from the feeding port on the tip of the bar. (F28)

- (1) Groove (2) Oiling port
- (3) Grease port (4) Sprocket

4. Others

Check for fuel leakage and loose fastenings and damage to major parts, especially handle joints and guide bar mounting. If any defects are found, make sure to have them repaired before operating again.

9. Maintenance

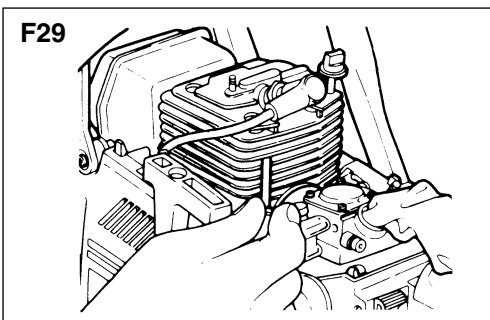

■ PERIODICAL SERVICE POINTS

1. Cylinder fins

Dust clogging between the cylinder fins will cause overheating of the engine. Periodically check and clean the cylinder fins after removing the air cleaner and the cylinder cover. When installing the cylinder cover, make sure that switch wires and grommets are positioned correctly in place. (F29)



NOTE

Be sure to block the air intake hole.

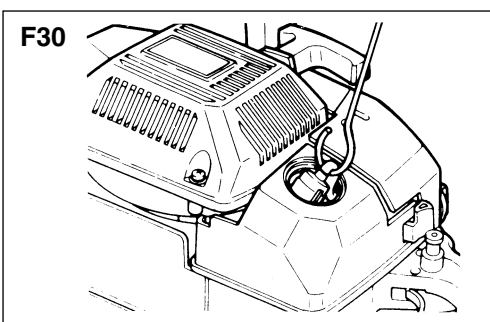

2. Fuel filter

- (a) Using a wire hook, take out the filter from the filler port. (F30)
- (b) Disassemble the filter and wash with gasoline, or replace with new one if needed. (F31)

- (1) Screen
- (2) Clip
- (3) Filter
- (4) Sleeve
- (5) Retainer

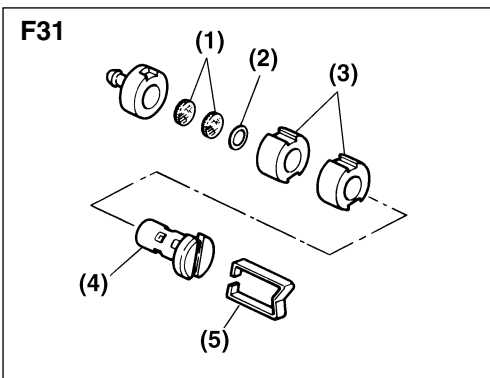

NOTE

- After removing the filter, use a pinch to hold the end of the suction pipe.
- When assembling the filter, take care not to allow filter fibers or dust inside the suction pipe.

3. Oil tank

With a wire hook, take out the oil filter through the filler port and clean in gasoline. When putting the filter back into the tank, make sure that it comes to the front right corner without bent. Also clean off dirt in the tank.

9. Maintenance

F32

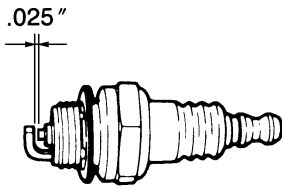

4. Spark plug (F32)

Clean the electrodes with a wire brush and reset the gap to 0.65 mm as necessary.

Champion: CJ-7Y
or
NGK: BPM7A

F33

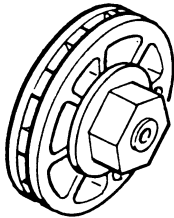

5. Sprocket (F33)

Check for cracks and for excessive wear interfering with the chain drive. If the wearing is found obviously, replace it with new one. Never fit a new chain on a worn sprocket, or a worn chain on a new sprocket.

6. Spark arrester

Remove the front Cover of the muffler and inspect the spark arresting screen. Brush off Carbon deposits as necessary. Replace if damaged.



NOTE

- When servicing the spark arrester, refer to the Service Parts List supplied with the unit for its location and correct assembly order of parts.
- Be sure to use a correct tool for the muffler nuts. The nuts are tightened firmly, and the use of inadequate tool will damage them.

7. Front and Rear dampers

Replace if adhered part is peeled or crack is observed on the rubber part.

Replace if the inside of the rear damper metal has been beaten by the stopper bolt and the clearance of the metal increased.

10. Maintenance of Saw Chain and Guide Bar

F34

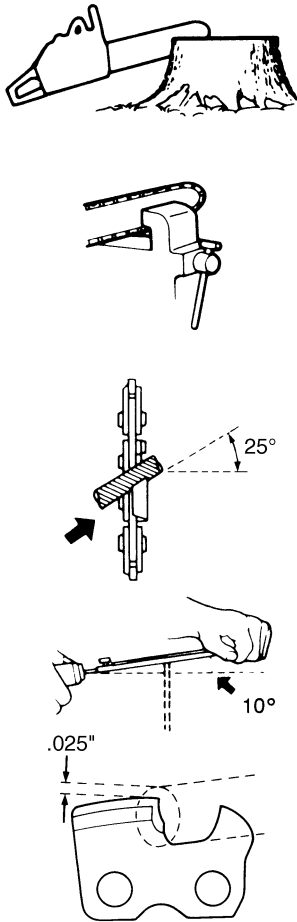

■ SAW CHAIN

⚠ WARNING

It is very important for smooth and safe operation to keep the cutters always sharp.

Your cutters need to be sharpened when:

- Sawdust becomes powder-like.
- You need extra force to saw in.
- The cut way does not go straight.
- Vibration increases.
- Fuel consumption increases.

Cutter setting standards:

⚠ WARNING

Be sure to wear safety gloves.

Before filing:

- Make sure the saw chain is held securely.
- Make sure the engine is stopped.
- Use a round file of proper size for your chain.

Chain type:	72V
File size:	7/32 in (5.5mm)

Place your file on the cutter and push straight forward. Keep the file position as illustrated. (F34)

F35

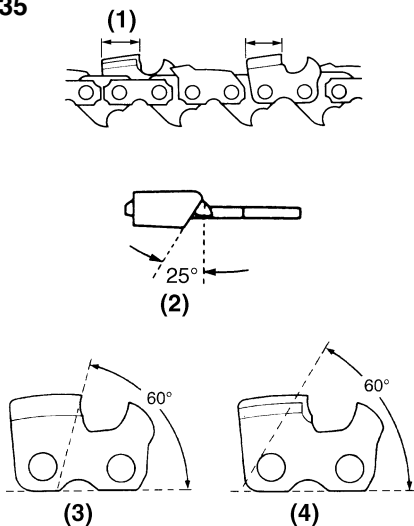

Make sure every cutter has the same length and edge angles as illustrated. (F35)

- (1) Cutter length
- (2) Filing angle
- (3) Side plate angle
- (4) Top plate cutting angle

10. Maintenance of Saw Chain and Guide Bar

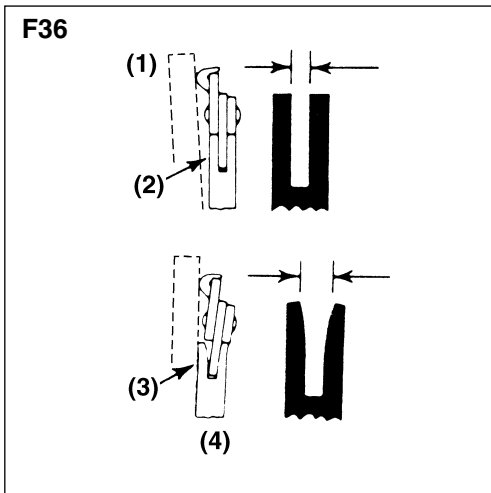

■ GUIDE BAR

- Reverse the bar occasionally to prevent partial wear.
- The bar rail should always be a square. Check for wear of the bar rail. Apply a ruler to the bar and the outside of a cutter. If a gap is observed between them, the rail is normal. Otherwise, the bar rail is worn. Such a bar needs to be corrected or replaced. (F36)

(1) Ruler

(2) Gap

(3) No gap

(4) Chain tilts

⚠ WARNING

This saw is equipped with one of the following low kickback bar/chain combinations:

Bar Size	RedMax Part Number	
	Guide Bar	Saw Chain
18" (45cm)	180RNDD176	72V66X
20" (50cm)	200RNDD176	72V70X
24" (60cm)	240RNDD176	72V81X

For replacement use only above bars and chains or the following:

OREGON BAR
18, 20, or 24 inch POWER MATCH®
(pitch: 3/8") Mount code #D176.

GB BAR
18, 20, or 24 inch PRO SPROCKET NOSE
(pitch: 3/8") Mount code #D176.
PRO TOP BAR (pitch: 3/8") Mount code E & EX

OREGON CHAIN
72V

11. Storage

1. Empty the fuel tank and run the engine out of fuel.
2. Empty the oil tank.
3. Clean the entire unit.
4. Store the unit in a dry place out of the reach of children.

12. Troubleshooting Guide

Case 1. Starting failure:

 **Make sure the icing prevention system is not working.**

Check fuel for water or substandard mixture.

→ Replace with proper fuel.



Check for engine flooding.

→ Remove and dry the spark plug.
Then pull the starter again with no choke.



Check the spark.

→ Replace with a new plug.

Case 2. Lack of power/Poor acceleration/Rough idling

Check fuel for water or substandard mixture.

→ Replace with proper fuel.



Check air filter and fuel filter for clogging.

→ Clean.



Check carburetor for inadequate adjustment.

→ Readjust speed needles.

Case 3. Oil does not come out

Check oil for substandard quality.

→ Replace.



Check oil passage and ports for clogging.

→ Clean.

When your unit seems to need further service, please consult with our service shop in your area.

13. Parts list

CHAINSAWS

G621AVS

NOTE :

1. Use KOMATSU ZENOAH genuine parts as specified in the parts list for repair and/or replacement.
2. KOMATSU ZENOAH does not warrant the machines, which have been damaged by the use of any parts other than those specified by the company.
3. When placing parts orders for repair and/or replacement, check if the model name and the serial number are applicable to those specified in the parts list, then use parts number described in the parts list.
4. The contents described in the parts list may change due to improvement.
5. The parts for the machine shall be supplied seven (7) years after the machine is discontinued. [It is possible that some specific parts may be subject to change of their delivery term and list price within the limit of seven (7) years after the machine is discontinued. It is also possible that some parts may be available even after the limit of seven (7) years.]

APPLICABLE SERIAL NUMBERS : 330138 and up

June 2005

13. Parts list

G621AVS

Fig.A-1 POWER UNIT (1)

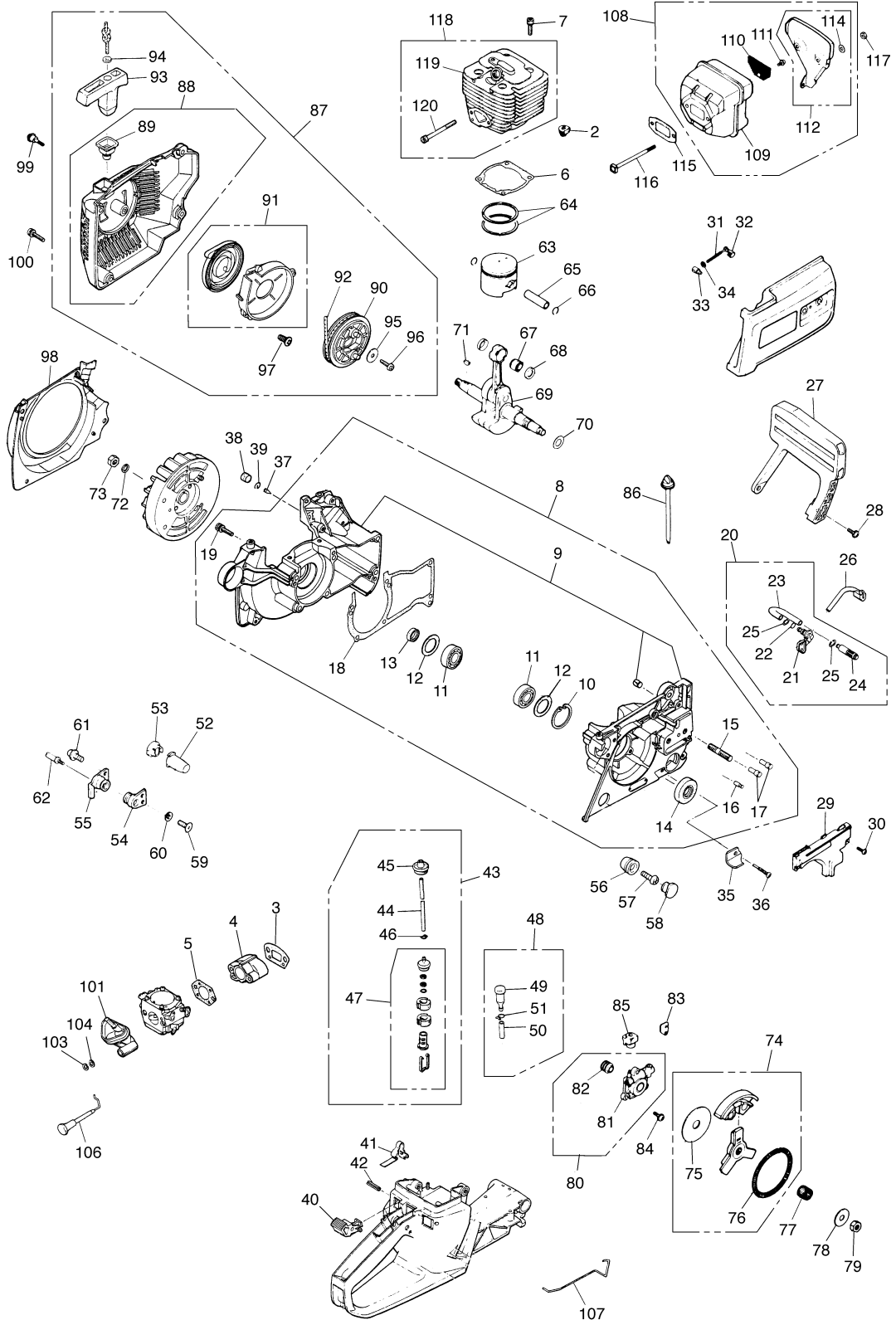

Fig.A-1 POWER UNIT (1)

G621AVS

Key#	PART NUMBER	DESCRIPTION	Q'TY /UNIT	NOTE	Key#	PART NUMBER	DESCRIPTION	Q'TY /UNIT	NOTE
2	3356-12141	Grommet	1		63	2618-41112	Piston	1	
3	848-C90-14B3	Gasket	1		64	2618-41210	Ring	2	
4	2618-14120	Insulator	1		65	3366-41310	Pin	1	
5	848-C90-14C2	Gasket	1		66	3350-41320	Ring	2	
6	2616-14211	Gasket	1		67	1400-41410	Bearing	1	
7	3310-12281	Bolt	4		68	2616-41510	Washer	2	
8	848-C90-2104	Crankcase assy	1		69	2616-42007	Crankshaft comp.	1	
9	848-C90-2112	• Crankcase comp.	1		70	1300-42410	Shim	0-2	OP
10	04065-03515	• Snap ring	1		71	1000-43240	Key	1	
11	T4012-21240	• Bearing	2		72	0290-21025	Washer	1	
12	2616-21250	• Ring	2		73	1300-43231	Nut	1	
13	3350-21210	• Seal	1		74	2616-51202	Clutch assy	1	
14	T1108-21220	• Seal	1		75	2616-51210	• Plate	1	
15	2616-21230	• Stud	2		76	3350-51231	• Spring	1	
16	3350-21250	• Pin	1		77	3320-41410	Bearing	1	
17	3356-21270	• Pin	2		78	3350-51320	Washer	1	
18	848-C90-21D2	• Gasket	1		79	3310-43220	Nut	1	
19	3310-12281	Bolt	6		80	848-C90-6703	Oil pump assy	1	
20	3356-23100	Oil pipe comp.	1		81	848-C90-6713	• Body	1	
21	3356-23110	• Pipe	1		82	3356-55120	• Worm	1	
22	07000-11008	• O-ring	1		83	3356-55310	Gasket	1	
23	3310-57312	• Pipe	1		84	0263-90520	Screw	3	
24	3310-57412	• Weight	1		85	3356-55450	Grommet	1	
25	3310-57511	• Clip	2		86	3356-55511	Shaft	1	
26	3356-23211	Pipe	1		87	2618-75004	Starter assy	1	
27	848-C92-54A1	Guard	1		88	2618-75103	• Case comp.	1	
28	2670-14320	Screw	1		89	2616-75120	•• Guide	1	
29	3356-24412	Cover	1		90	3350-75213	• Reel	1	
30	0263-60514	Screw	2		91	3356-75302	• Spring comp.	1	
31	3350-25111	Screw	1		92	3356-75410	• Rope	1	
32	3350-25121	Stopper	1		93	3350-75420	• Knob	1	
33	3320-21191	Nut (A)	1		94	3310-75431	• Washer	1	
34	01641-20508	Washer	1		95	3320-75350	• Washer	1	
35	2616-25211	Catcher	1		96	1490-32120	• Screw	1	
36	2616-25230	Screw	1		97	2630-82550	• Screw	2	
37	3330-23121	Valve	1		98	3366-75612	Cover	1	
38	3350-26220	Seal	1		99	848-C90-75Z1	Screw	1	
39	3350-26230	Clip	1		100	2616-75720	Screw	3	
40	3350-34210	Lever	1		101	3356-82114	Manifold	1	
41	3356-34221	Spring	1		103	01601-20513	Washer	2	
42	2616-34230	Pin	1		104	01641-20508	Washer	2	
43	3356-34301	Fuel pipe assy	1		106	2616-82310	Rod	1	
44	3356-34310	• Pipe	1		107	2616-82410	Rod	1	
45	3356-34320	• Grommet	1		108	848-C91-1510	Muffler assy	1	
46	1260-85460	• Clip	1		109	3359-15112	• Muffler	1	
47	3302-85400	• Filter assy	1		110	3357-15120	• Spark arrester	1	
48	3350-34501	Breather assy	1		111	0263-20408	• Screw	1	
49	3317-86100	• Breather	1		112	848-C91-1520	• Cover set	1	
50	3350-34540	• Pipe	1		114	01640-20610	•• Washer	2	
51	1260-85460	• Clip	1		115	3356-15210	Gasket	1	
52	2616-35112	Front damper	2		116	3356-15220	Bolt	2	
53	3356-35121	Cap	2		117	3356-15230	Nut	2	
54	2616-35151	Rear damper (R)	1		118	848-C90-1260	Cylinder set	1	
55	2616-35132	Rear damper (L)	1		119	848-C90-12A7	• Cylinder	1	
56	2616-35141	Rear damper (B)	1		120	848-815-8500	• Bolt	2	
57	1490-32120	Screw	1						
58	2856-35180	Cap	1						
59	0262-10514	Screw	2						
60	3320-14140	Washer	2						
61	2616-25320	Screw	2						
62	2616-35170	Bolt	2						

Fig.A-2 POWER UNIT (2)

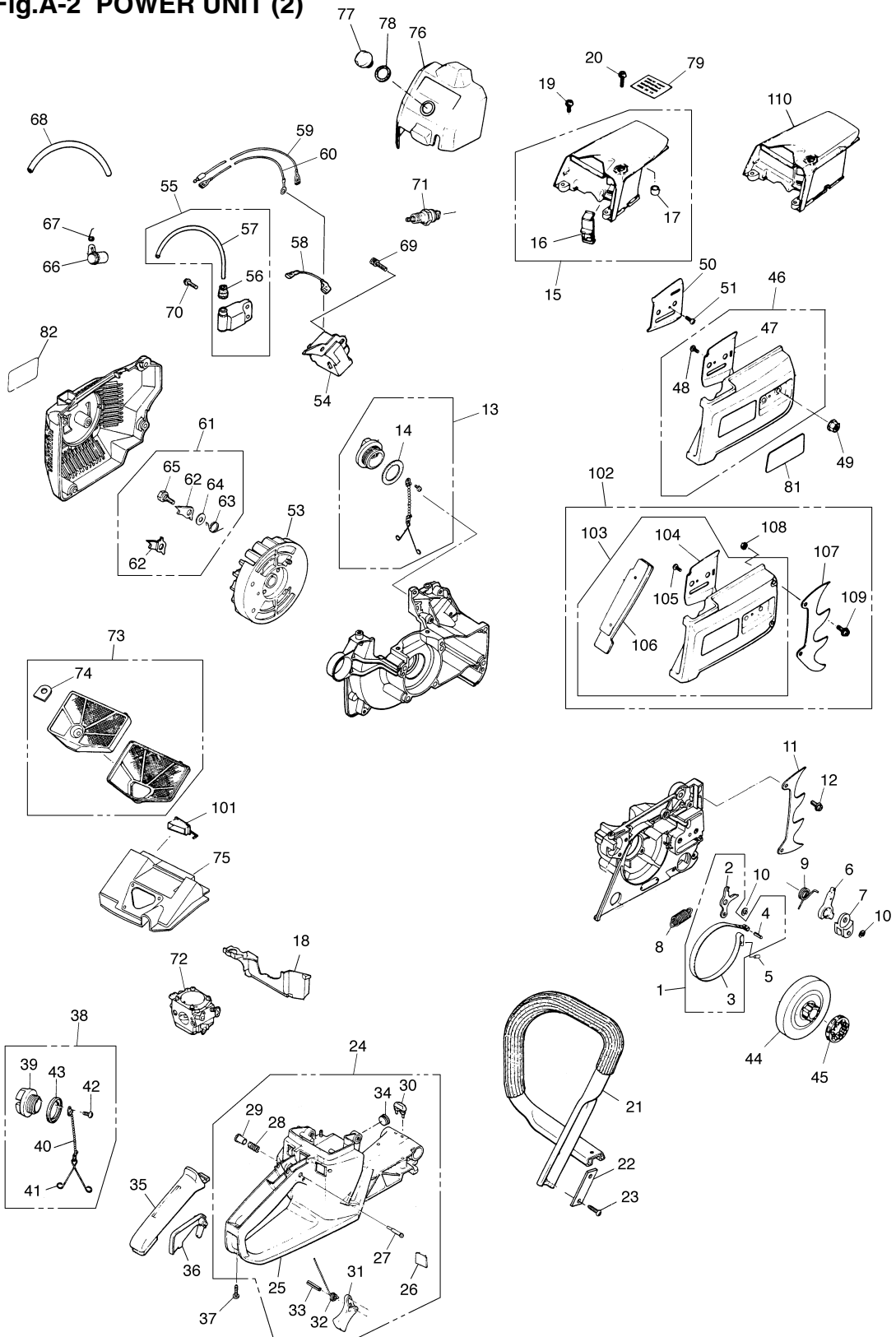

Fig.A-2 POWER UNIT (2)

G621AVS

Key#	PART NUMBER	DESCRIPTION	Q'TY /UNIT	NOTE	Key#	PART NUMBER	DESCRIPTION	Q'TY /UNIT	NOTE
1	3356-24101	Brake band comp.	1		60	2616-71430	Cord	1	
2	3356-24111	• Band	1		61	2618-71102	Rotor comp.	1	
3	3356-24120	• Arm	1		62	3366-71120	• Ratchet	2	
4	04025-00408	• Pin	1		63	3350-71131	• Spring	2	
5	3356-24140	Roller	1		64	3388-71150	• Washer	2	
6	2622-24210	Lever	1		65	3310-71142	• Bolt	2	
7	848-C92-5431	Stopper	1		66	2850-72110	Cap	1	
8	2622-24600	Spring	1		67	1400-72121	Spring	1	
9	3356-24240	Spring	1		68	2850-71320	Tube	1	
10	0308-00060	Snap ring	2		69	3350-15250	Bolt	2	
11	2623-25310	Spike	1		70	0263-30416	Screw	2	
12	2616-25320	Screw	2		71	3699-90002-10	Spark plug	1	CJ-7Y
13	3356-26100	Cap assy	1		72	3369-81000	Carburetor	1	See Fig.B
14	3317-57220	• Gasket	1		73	848-C91-8311	Air cleaner comp.	1	Net type
15	848-C90-3114	Cover comp.	1		74	848-C90-83C0	• Plate	1	
16	3356-31120	• Cap	1		75	3369-83200	Silencer	1	
17	3356-31152	• Grommet	1		76	2622-83302	Cover comp.	1	
18	3356-31212	Seal	1		77	3356-83322	• Knob	1	
19	0263-90514	Screw	2		78	3388-83340	• Gasket	1	
20	0263-90520	Screw	1		79	3369-31163	Label	1	
21	2620-32100	Left handle comp.	1						
22	2851-32180	Plate	2		81	3359-53121	Label	1	
23	848-825-1901	Screw	4		82	3369-75131	Label	1	
24	2622-33005	Right handle assy	1						
25	2622-33105	• Right handle comp.	1						
26	3350-33220	• Plate	1						
27	3330-33250	• Stopper	1						
28	3310-33262	• Spring	1		101	2610-83220	Cap	1	OP
29	3310-33271	• Knob	1		102	2623-06012	Double spike kit	1	OP
30	2810-33280	• Damper (A)	1		103	2618-53002	• Chain cover assy	1	OP
31	848-C10-33C3	• Lever	1		104	3356-53220	•• Plate	1	
32	3356-33321	• Spring	1		105	0261-00410	•• Screw	1	K8
33	04025-00524	• Pin	1		106	2616-53300	•• Protector	1	OP, K8
34	2616-33412	• Damper (B)	1		107	2618-53510	• Spike	1	OP, K8
35	3356-34111	Cover	1		108	3310-53331	• Nut	2	OP, K8
36	848-C30-33E3	Arm	1		109	2670-14320	• Screw	2	OP, K8
37	3356-32210	Screw	1		110	2626-31110	Cover	1	OP
38	3350-34400	Cap assy	1						
39	3350-26110	• Cap	1						
40	3317-57230	• Chain	1						
41	3317-57240	• Stopper	1						
42	0277-10410	• Screw	1						
43	3350-34450	• Gasket	1						
44	3350-51110	Drum	1						
45	3360-51120	Sprocket	1	3/8Px7T					
46	3356-53003	Chain cover assy	1						
47	3356-53220	• Plate	1	K8					
48	0277-10410	• Screw	1						
49	3350-53410	Nut	2						
50	3356-53210	Plate	1						
51	0261-00410	Screw	1						
53	2616-71112	Rotor	1						
54	848-C90-71B1	Source coil	1						
55	2616-71301	Ignition coil comp.	1						
56	2616-71320	• Cap	1						
57	2616-71331	• Cord	1						
58	2616-71410	Cord	1						
59	2616-71420	Cord	1						

Fig.B CARBURETOR		Key#	PART NUMBER	DESCRIPTION	Q'TY /UNIT	NOTE
		1	3369-81000	Carburetor assy	1	
		2	3306-81380	Screen	1	
		3	3350-81130	Cover	1	
		4	3350-81140	Cover	1	
		5	3366-81151	Shaft assy	1	
		6	3366-81340	Valve	1	
		7	3356-81171	Shaft assy	1	
		8	2629-81180	Valve	1	
		9	1488-81190	Stop	1	
		10	3356-81310	Valve	1	
		11	3350-81220	Ball	1	
		12	3350-81230	Gasket	1	K2
		13	3350-81240	Gasket	1	K2
		14	3350-81250	Lever	1	
		15	2618-81260	Diaphragm	1	K3
		16	3350-81270	Diaphragm	1	K3
		17	2880-81470	Screw	3	
		18	3310-81240	Screw	1	
		19	1491-81130	Screw	1	
		20	3310-81250	Pin	1	
		21	2670-81430	Screw	1	
		22	3310-81351	Screw assy	4	
		23	3350-81350	Spring	1	
		24	3415-81490	Cap limiter	2	
		25	3350-81370	Spring	1	
		26	3350-81380	Spring	1	
		27	3350-81391	Spring	1	
		28	3369-81410	Needle (H)	1	
		29	3369-81420	Needle (L)	1	
		30	1480-81420	Plug	1	
		31	3356-81430	Plug	1	

Fig.C ACCESSORIES		Key#	PART NUMBER	DESCRIPTION	Q'TY /UNIT	NOTE
		1	3320-91140	Wrench	1	
		2	2670-91150	Screwdriver	1	
		3	3356-97110	Bar protector	1	OP, 18"
		4	3665-97110	Bar protector	1	OP, 20" & 24"
		5	3369-93110	Owners manual	1	

Fig.D CUTTING HEAD		Key#	PART NUMBER	DESCRIPTION	Q'TY /UNIT	NOTE
<p>1A 1B 1C</p> <p>2A 2B 2C</p>	1A	180RNDD176	Bar 18"		1	
	1B	200RNDD176	Bar 20"		1	
	1C	240RNDD176	Bar 24"		1	
	2A	72V66X	Chain for 18"		1	3/8P
	2B	72V70X	Chain for 20"		1	3/8P
	2C	72V81X	Chain for 24"		1	3/8P

Fig.E SPECIAL TOOLS		Key#	PART NUMBER	DESCRIPTION	Q'TY /UNIT	NOTE
<p>1</p> <p>2</p> <p>3</p> <p>4</p> <p>5</p> <p>6</p> <p>7</p>	1	2890-96100	Puller assy		1	OP
	2	2616-96210	Wrench		1	OP
	3	3350-96220	Stopper		1	OP
	4	3350-96240	Gauge		1	OP
	5	3350-96510	Guide		1	OP
	6	3330-97210	Wrench		1	OP
	7	3356-96230	Guide		1	OP

KIT PARTS

Key#	PART NUMBER	DESCRIPTION	Q'TY /UNIT	NOTE
K2	3350-06020	Gasket kit	1	OP
K3	3350-06030	Diaphragm kit	1	OP
K8	2623-06012	Double spike kit	1	OP

RedMax

CHAIN SAWS LIMITED WARRANTY

EMISSION-RELATED PARTS, FOR TWO (2) YEARS FROM THE DATE OF ORIGINAL DELIVERY, KOMATSU ZENOAH AMERICA INC. (THE COMPANY), THROUGH ANY RedMax DEALER, WILL REPAIR OR REPLACE, FREE OF CHARGE, FOR THE ORIGINAL AND EACH SUBSEQUENT PURCHASER, ANY PART OR PARTS FOUND TO BE DEFECTIVE IN MATERIAL AND/OR WORKMANSHIP. EMISSION-RELATED PARTS ARE:

**THE CARBURETOR ASSY, COIL ASSY, ROTOR, SPARKPLUG,
AIR FILTER, FUEL FILTER, INTAKE MANIFOLD, AND THE GASKETS**

ALL OTHER PARTS EXCEPT ABOVE PARTS, FOR TWO (2) YEARS OF HOME USE, 1 YEAR COMMERCIAL USE AND NINETY (90) DAYS FOR RENTAL USE FROM THE DATE OF ORIGINAL PURCHASE, THE COMPANY, THROUGH ANY RedMax DEALER, WILL REPAIR OR REPLACE, FREE OF CHARGE, FOR THE ORIGINAL PURCHASER, ANY PART OF PARTS FOUND TO BE DEFECTIVE IN MATERIAL AND/OR WORKMANSHIP. **THIS IS THE EXCLUSIVE REMEDY.**

THE PURCHASER SHALL BEAR COSTS OF TRANSPORTING THE UNIT TO AND FROM THE RedMax DEALER.

THE PURCHASER SHALL NOT BE CHARGED FOR DIAGNOSTIC LABOR WHICH LEADS TO THE DETERMINATION THAT A WARRANTED PART IS DEFECTIVE, IF THE DIAGNOSTIC WORK IS PERFORMED AT THE RedMax DEALER.

THE PURCHASER OR OWNER IS RESPONSIBLE FOR THE PERFORMANCE OF THE REQUIRED MAINTENANCE AS DEFINED BY THE MANUFACTURER IN THE OWNER/OPERATOR MANUAL.

ANY WARRANTED PART WHICH IS NOT SCHEDULED FOR REPLACEMENT AS REQUIRED MAINTENANCE, OR WHICH IS SCHEDULED ONLY FOR REGULAR INSPECTION TO THE EFFECT OF "REPAIR OR REPLACE AS NECESSARY" SHALL BE WARRANTED FOR THE WARRANTY PERIOD. ANY WARRANTED PART WHICH IS SCHEDULED FOR REPLACEMENT AS REQUIRED MAINTENANCE SHALL BE WARRANTED FOR THE PERIOD OF TIME UP TO THE FIRST SCHEDULED REPLACEMENT POINT FOR THE PART.

ANY REPLACEMENT PART THAT IS EQUIVALENT IN PERFORMANCE AND DURABILITY MAY BE USED IN NON-WARRANTY MAINTENANCE OR REPAIRS, AND SHALL NOT REDUCE THE WARRANTY OBLIGATION OF THE COMPANY.

THE COMPANY IS LIABLE FOR DAMAGES TO OTHER ENGINE COMPONENTS CAUSED BY THE FAILURE OF A WARRANTED PARTS STILL UNDER WARRANTY.

THE WARRANTY DOES NOT APPLY TO THOSE UNITS WHICH HAVE BEEN DAMAGED BY NEGLIGENCE OF INSTRUCTION LISTED IN THE OWNER/OPERATOR MANUAL FOR PROPER USE AND MAINTENANCE OF THE UNITS, ACCIDENTAL MISHANDLING, ALTERATION, ABUSE, IMPROPER LUBRICATION, USE OF ANY PARTS OR ACCESSORIES OTHER THAN THOSE SPECIFIED BY THE COMPANY, OR OTHER CAUSES BEYOND THE COMPANY'S CONTROL.

THIS WARRANTY DOES NOT COVER THOSE PARTS REPLACED BY NORMAL WEAR OR HARMLESS CHANGES IN THEIR APPEARANCE.

THERE ARE NO OTHER EXPRESS WARRANTIES.

IMPLIED WARRANTIES INCLUDING THOSE OF MERCHANTABILITY AND FITNESS FOR A PARTICULAR PURPOSE **ARE LIMITED TO** TWO (2) YEARS FOR HOME USE, ONE (1) YEAR FOR COMMERCIAL USE AND NINETY (90) DAYS FOR RENTAL USE, FROM THE ORIGINAL DELIVERY DATE.

LIABILITIES FOR INCIDENTAL OR CONSEQUENTIAL DAMAGE UNDER ANY AND ALL WARRANTIES ARE EXCLUDED.

SOME STATES DO NOT ALLOW LIMITATION ON HOW LONG AN IMPLIED WARRANTY LASTS OR EXCLUSION OR LIMITATION OF INCIDENTAL OR CONSEQUENTIAL DAMAGES, SO THE ABOVE LIMITATION OR EXCLUSION MAY NOT APPLY TO YOU.

THIS WARRANTY GIVES YOU SPECIFIC LEGAL RIGHTS, AND YOU MAY ALSO HAVE OTHER RIGHTS WHICH VARY FROM STATE TO STATE.

IF YOU NEED TO OBTAIN INFORMATION ABOUT THE NEAREST SERVICE CENTER, PLEASE CALL KOMATSU ZENOAH AMERICA INC. AT (770)-381-5147.

IMPORTANT: YOU WILL RECEIVE A WARRANTY REGISTRATION CARD AT TIME OF PURCHASE. PLEASE FILL OUT THE CARD AND SEND IT TO RedMax / KOMATSU ZENOAH AMERICA WITHIN SEVEN (7) DAYS. BE SURE TO KEEP A COPY FOR YOUR RECORDS.



KOMATSU ZENOAH AMERICA INC.
4344 Shackelford Road Suite 500
Norcross, Georgia 30093

RedMax

Garantie limitée des tronçonneuses

Pièces en rapport avec les émissions de gaz d'échappement : KOMATSU ZENOAH AMERICA INC., par l'intermédiaire de n'importe quel revendeur RedMax, réparera gratuitement ou remplacera gratuitement pour l'acheteur initial et chaque acheteur successif toute(s) pièce(s) se révélant de constitution et/ou de montage défectueux pendant deux (2) ans à compter de la date initiale de livraison d'une unité. Les pièces en rapport avec les émissions de gaz d'échappement sont:

**l'assemblage carburateur, l'assemblage bobine, le rotor, la bougie,
le filtre à air, le filtre à carburant, la tubulure d'admission et les joints**

Toutes les pièces autres que celles mentionnées ci-dessus, deux (2) ans d'utilisation domestique, 1 an d'utilisation commerciale et quatre-vingt-dix (90) jours pour la location à compter de la date d'achat initial. La société, par l'intermédiaire d'un distributeur RedMax, réparera ou remplacera toute(s) pièce(s), sans frais et au bénéfice de l'acheteur original, en prenant en charge les frais de pièces et/ou de main d'œuvre. **Telles sont les limites de la garantie.**

Le coût du transport de l'unité jusqu'au revendeur RedMax et depuis celui-ci sera à la charge de l'acheteur.

L'acheteur ne supportera pas le coût de main d'œuvre du diagnostic qui amène à la conclusion qu'une pièce garantie est défectueuse, si ce diagnostic est effectué chez le revendeur RedMax.

L'acheteur ou propriétaire a pour responsabilité d'effectuer l'entretien obligatoire tel que défini par le fabricant dans le manuel du propriétaire/de l'utilisateur.

Toute pièce garantie dont le remplacement n'est pas prévu dans le cadre de l'entretien obligatoire, ou pour laquelle est seulement prévue une inspection périodique pour "remplacement ou réparation si nécessaire" sera garantie pour la période de garantie. Toute pièce garantie arrivée à l'échéance de son premier remplacement prévu sera garantie jusqu'à celui-ci.

Toute pièce de rechange équivalente en performance ou en durabilité peut être utilisée pour l'entretien hors-garantie ou les réparations hors-garantie, et ce sans réduire l'obligation de garantie incombant à la société.

La société sera tenue responsable des dommages aux autres composants du moteur causés par la défaillance de pièce(s) garantie(s) en période de garantie.

La garantie ne s'applique pas aux unités endommagées par suite de: négligence dans la mise en oeuvre des instructions spécifiées dans le manuel du propriétaire/de l'utilisateur en vue d'une utilisation et d'un entretien correct, fausse manœuvre accidentelle, modification, utilisation abusive, lubrification incorrecte, utilisation de pièces ou d'accessoires autres que ceux spécifiés par la société, ou autres causes hors du contrôle de la société.

Cette garantie ne couvre pas les pièces remplacées en raison de leur usure normale ou de changements d'apparence sans effets.

Il n'existe aucune autre garantie explicite.

Les garanties implicites, y compris la valeur marchande et la valeur d'usage pour une utilisation particulière, **sont limitées** à deux (2) ans d'utilisation domestique, un (1) an d'utilisation commerciale et quatre-vingt-dix (90) jours pour la location, à compter de la date originale de livraison.

Les responsabilités pour les dommages conséquents ou incidents sont exclues de toutes les garanties.

Certaines provinces n'autorisant pas les limitations à la durée des garanties implicites, ou les exclusions ou limitations relatives aux dommages incidents ou conséquents, la limitation indiquée ci-dessus peut ne pas vous être applicable.

Cette garantie vous donne des droits juridiques spécifiques, et vous pouvez également jouir d'autres droits variant d'une province à l'autre.

Si vous désirez obtenir des informations sur le centre de service le plus proche, veuillez appeler KOMATSU ZENOAH AMERICA INC. au (770)-381-5147

Note importante: vous recevrez une carte d'enregistrement de garantie au moment de l'achat. Veuillez la remplir et l'adresser à RedMax / KOMATSU ZENOAH AMERICA sous sept (7) jours en prenant soin de conserver une copie pour vous.



KOMATSU ZENOAH AMERICA INC.
4344 Shackelford Road Suite 500
Norcross, Georgia 30093



KOMATSU ZENOAH AMERICA INC.
4344 Shackleford Road Suite 500
Norcross, Georgia 30093

© Printed in Japan

Free Manuals Download Website

<http://myh66.com>

<http://usermanuals.us>

<http://www.somanuals.com>

<http://www.4manuals.cc>

<http://www.manual-lib.com>

<http://www.404manual.com>

<http://www.luxmanual.com>

<http://aubethermostatmanual.com>

Golf course search by state

<http://golfingnear.com>

Email search by domain

<http://emailbydomain.com>

Auto manuals search

<http://auto.somanuals.com>

TV manuals search

<http://tv.somanuals.com>