



**FOR THE MOST IMPORTANT PEOPLE  
IN THE WORLD**

***TRAVEL DINER***<sup>™</sup>  
*PORTABLE HOOK-ON HIGH CHAIR*

Models: 2772  
Owner's Manual  
06/21/2013\_DC



**WARNING:**

- READ ALL INSTRUCTIONS BEFORE ASSEMBLY AND USE OF CHAIR.
- KEEP INSTRUCTIONS FOR FUTURE USE.

[www.regalo-baby.com](http://www.regalo-baby.com)

---

**Regalo International, LLC.**

3200 Corporate Center Drive, Suite 100

Burnsville, MN 55306-9803, USA

Toll Free: 866-272-5274

Made in China

# **WARNING:**

Failure to follow these warnings could result in serious injury or death.

- Be sure hook-on chair is securely attached to table before seating child.
- The child should be secured in the hook-on chair at all times by restraining system.
- Never leave child unattended. Always keep child in view when in hook-on chair.
- Check stability of table before and after seating child.
- Do not use on a glass, or a loose tabletop, table leaf, or single pedestal or card table, or with table cloths or placemats.
- Discontinue use if hook-on chair is broken. Contact manufacturer immediately for replacement parts or service.
- Do not place an ordinary chair under this hook-on chair or position this hook-on chair on counters or tables which are near other structures that could be used by the child to push the hook-on chair off or up from the table or counter.
- Do not use without all tips (suction cups or other locking/latching mechanisms) attached securely to table surface.
- Keep seat and table surface clean and dry to prevent seat from slipping.
- Use only for a child capable of sitting upright unassisted.
- Discontinue use if child, when seated in hook-on chair, is able to move the hook-on chair arms on the table top.
- Do not allow other children or animals to play near or walk under hook-on chair while in use.
- Use only for children up to 37 pounds (16.8kg).
- Use only for tables 1 to 2 inch. thick (25 - 51mm).
- Before removing child from hook-on chair, be sure child's legs are free from hook-on chair supports.
- Always ensure that all hazards such as electrical devices, knives and hot liquids are kept out of reach of the child in the chair.
- Do not hang objects from the chair.
- Do not use the table seat for more than one child at a time.
- Do not use table cloths or other objects on the surface of the table top which may interfere with the function of the securing mechanism.

READ ALL INSTRUCTIONS BEFORE ASSEMBLY AND USE OF CHAIR. KEEP INSTRUCTIONS FOR FUTURE USE.

## ASSEMBLING YOUR TRAVEL DINER CHAIR

1. Remove the black plastic protective caps from the ends of the backrest bar. These black plastic caps are for packing purpose only and should be discarded.

If the backrest bar (U - shaped) is not fitted, slide the arm through the sleeve at the back of the seat cover until the pins on the tube are exposed on either side of the sleeve.



2. Assess the position of each arm. For the correct position of each arm you must have:

- a. Round rubber stopper positioned at front.
- b. Round lock release button on clamp must face the outside of the chair.
- c. Rubber paddle - grip positioned at top.



3. Slide each paddle-grip through the cover of each sleeve located on the side of the seat. Insert from the back of the sleeve and push the arm through.

\*Remember, the lock release button on the clamp must facing to the outside.

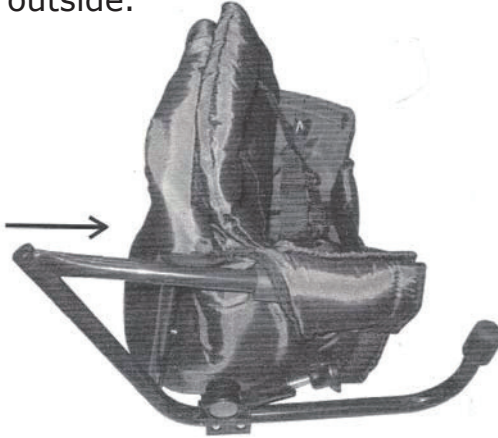

4. Remove the black plastic protective caps from the openings of both arms and discard them. The caps are only for packaging purposes. Next, attach both arms onto the backrest bar, pushing the spring pin in, as you slide the arms over the backrest bar.

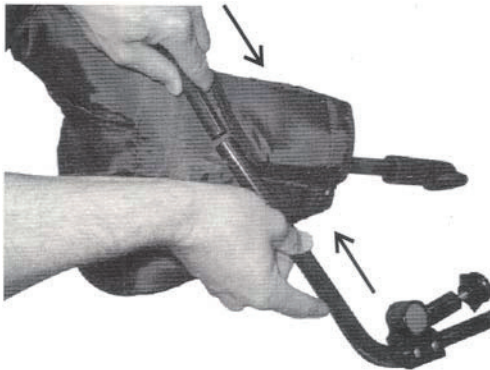

# TIPS FOR INSTALLING YOUR TRAVEL DINER CHAIR

## Step 1.

Make sure the two locks (H) are angled forward (see the position in Diagram (1)). Press in the lock release button (D) to do this. Fit onto a table or suitable flat surface as shown in Diagram (1)

**NOTE: Your Travel Diner WILL be noticeably angled when first placed on the table top. THIS IS NORMAL. Proceed to Step 2.**

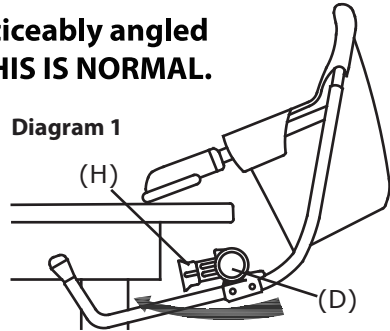

## Step 2.

Install the Travel Diner on the table top as shown in the Diagram 2a. Then, push down on the back of the Travel Diner as indicated by the arrow in Diagram 2b, until the seat is almost level with the table top. Next, pivot the locks back until they automatically lock in the vertical position as shown in Diagram 2c.

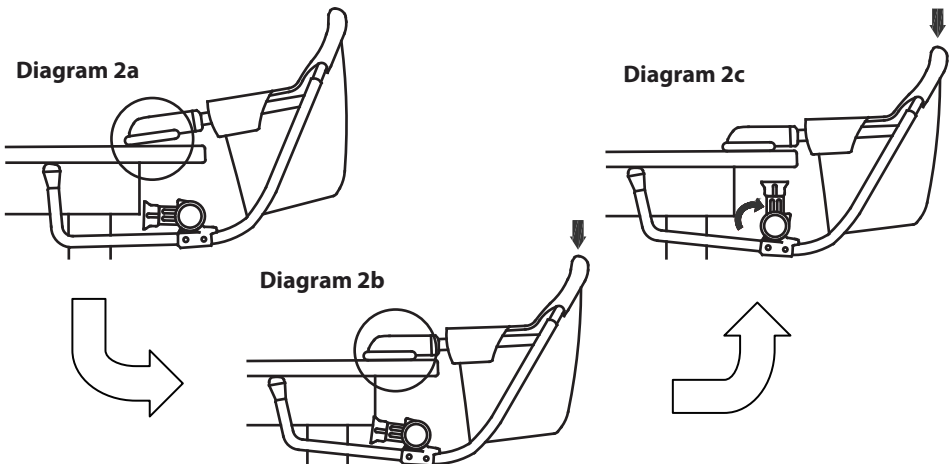

### Step 3.

To lock your Travel Diner onto the table, continue pushing down on the back of the Travel Diner and at the same time turn the plastic locking knobs ( J ) clockwise as indicated by the arrow in this diagram 3. Continue turning the locking knobs until they are tight against the bottom of the table surface. Your Travel Diner should now be securely locked to the table top. If properly locked to the table top, you should not be able to pull your Travel Diner off the table, even when pulling with a reasonable amount of force.

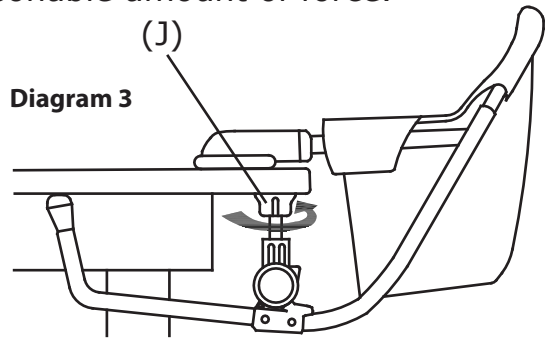

## HARNESS INSTRUCTIONS

To secure your child in the harness, push buckle tongues (A) into buckle housing (B) and adjust with waist strap adjuster so that the waist strap is firmly secured around child. Attach shoulder straps in position on buckle tongues (A) and adjust so that they are secure, yet comfortable on child.

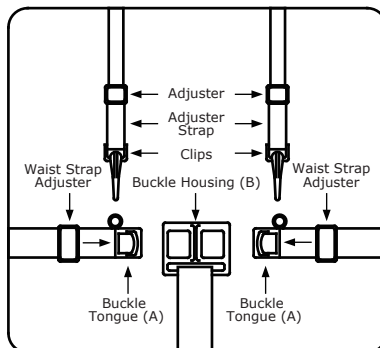

# CLOSING THE TRAVEL DINER CHAIR

Before attempting to close the Diner Chair, remove your child. Loosen the table locks on the Diner Chair arms. Press in the lock release buttons and angle the table locks forward. Remove the Diner Chair from the table. Fold the Diner Chair seat arms inward to store the Diner Chair.

## CARE AND MAINTENANCE

Periodically check the Diner Chair for sign of damage, wear or for missing components. Do not use if any part is missing, worn or damaged. Always dry metal parts to avoid the formation of rust. Regularly check the securing screws to ensure that they are securely tightened and tighten when necessary.

## FABRIC CARE

Always check the strength of the fabric and the strength of the stitching each time the fabric is washed.



## 90 Days Limited Warranty:

If, during the first 90 days after consumer purchase of this item, under reasonable and non-commercial use and conditions of maintenance, it fails while owned by the original purchaser because of the quality of materials or workmanship of finish and assembly, Regalo International LLC will replace or repair it at Regalo's option, proof of purchase required.

If you have any questions or comments contact:

Regalo, International

Toll free: 866-272-5274

<http://www.regalo-baby.com>

Made in China.



**Regalo International, LLC.**

3200 Corporate Center Drive, Suite 100

Burnsville, MN 55306-9803, USA

Toll Free: 866-272-5274

Made in China

06/21/2013\_DC



## Free Manuals Download Website

<http://myh66.com>

<http://usermanuals.us>

<http://www.somanuals.com>

<http://www.4manuals.cc>

<http://www.manual-lib.com>

<http://www.404manual.com>

<http://www.luxmanual.com>

<http://aubethermostatmanual.com>

Golf course search by state

<http://golfingnear.com>

Email search by domain

<http://emailbydomain.com>

Auto manuals search

<http://auto.somanuals.com>

TV manuals search

<http://tv.somanuals.com>