

RUF 100 199 SERIES 100 AND 101

COMMERCIAL GAS WATER HEATER

GAS-FIRED POWER BURNER FOR DOMESTIC HOT WATER



• INSTALLATION • OPERATION • SERVICE • MAINTENANCE • LIMITED WARRANTY

⚠ WARNING: If the information in these instructions is not followed exactly, a fire or explosion may result causing property damage, personal injury or death.

- Do not store or use gasoline or other flammable vapors and liquids in the vicinity of this or any other appliance.
- **WHAT TO DO IF YOU SMELL GAS:**
 - Do not try to light any appliance.
 - Do not touch any electrical switch; do not use any phone in your building.
 - Immediately call your gas supplier from a neighbor's phone. Follow the gas supplier's instructions.
 - If you cannot reach your gas supplier, call the fire department.
- Installation and service must be performed by a qualified installer, service agency or the gas supplier.



Thank you for buying this energy efficient water heater. We appreciate your confidence in our products.

⚠ CAUTION

TEXT PRINTED OR UNDERLINED IN RED CONTAINS INFORMATION RELATIVE TO YOUR SAFETY. PLEASE READ THOROUGHLY BEFORE INSTALLING AND USING THIS APPLIANCE.

PLACE THESE INSTRUCTIONS ADJACENT TO HEATER AND NOTIFY OWNER TO KEEP FOR FUTURE REFERENCE.

RUF 100 199 ROUGH-IN-DIMENSIONS

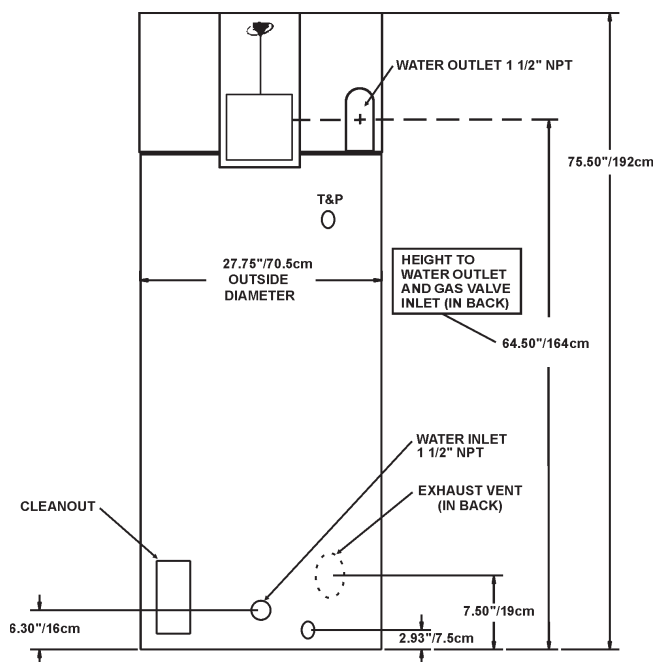
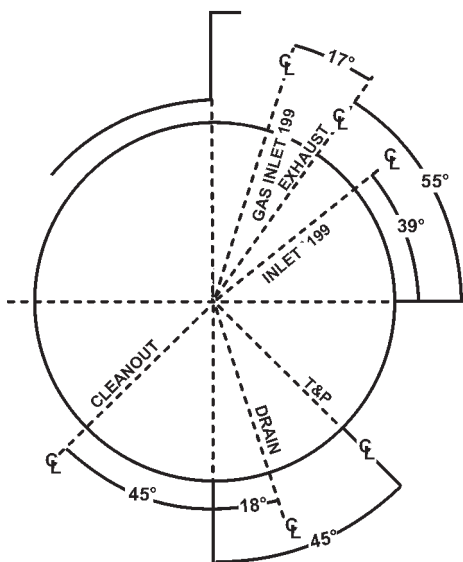

GAS VALVE PIPING	
RUF - 199	1/2" NPT

Table 1. RECOVERY CAPACITIES - NATURAL GAS / L.P.

Model	Input BTU/Hr.	Gas Usage	Approx. Gallon Capacity	TEMPERATURE RISE - DEGREES °F - GALLONS PER HOUR													
				30	40	50	60	70	80	90	100	110	120	130	140		
RUF 199	199,900	nat/lp	100	767	575	460	384	329	288	256	230	209	192	177	164		

Model	Gas kW-Hr	Liter Usage	Approx. Capacity	TEMPERATURE RISE - DEGREES C - Liters PER HOUR													
				17	22	28	33	39	44	50	56	61	67	72	78		
RUF 199	58	nat/lp	379	2904	2178	1743	1452	1245	1089	968	871	792	726	670	622		

Recovery capacities are based on 95% thermal efficiency.

FOREWORD

These designs comply with the current version of the American National Standard for Gas Water Heaters, Volume III, ANSI Z21.10.3 / CSA 4.3 as an automatic circulating tank water heater, and automatic storage water heaters.

Detailed installation diagrams are found in this manual. These diagrams will serve to provide the installer with a reference for the materials and methods of piping necessary. It is highly essential that all water, gas piping and wiring be installed as shown on the diagrams.

Particular attention should be given to the installation of thermometers at the locations indicated on the diagrams as these are necessary for checking the proper functioning of the heater.

In addition to these instructions, the equipment shall be installed in accordance with those installation regulations in force in the local area where the installation is to be made. These shall be carefully followed in all cases. Authorities having jurisdiction should be consulted before installations are made.

In the absence of local codes, the installation must comply with the current editions of the National Fuel Gas Code, ANSI Z223.1/NFPA 54 and the National Electrical Code, NFPA 70. All documents are available from the Canadian Standards Association, 8501 East Pleasant Valley Road, Cleveland, OH 44131. NFPA documents are also available from the National Fire Protection Association, 1 Batterymarch Park, Quincy, MA 02269.

TABLE OF CONTENTS

PAGE	PAGE
ROUGH-IN DIMENSIONS..... 2	Gas Valves..... 14
FOREWORD..... 2	SYSTEM CONNECTIONS..... 14
FEATURES..... 3,4	Thermometers..... 14
Water Temperature Control..... 3	Relief Valve..... 14
High Limit Switch (E.C.O.)..... 4	Water Line Connections..... 14
Dishwashing Machine Requirement..... 4	Heater Wiring..... 15
Circulating Pump..... 4	USING THE ELECTRONIC CONTROLLER..... 16
INSTALLATION INSTRUCTIONS..... 4-11	Overview..... 17
Required Ability..... 4	Operating States..... 17
Insulation Blankets..... 4	Adjusting the Operating Set Point..... 17
Locating The Heater..... 5	Changing the Display Units..... 18
Clearances..... 5	Fault and Alert Conditions..... 18
Hard Water..... 6	Access to the Current Fault or Alert..... 18
Air Requirements..... 6	Viewing the Fault History..... 19
Mechanical Exhausting of Room Air..... 6	PRIOR TO START-UP..... 19
Unconfined Space..... 6	Required Ability..... 19
Confined Space..... 6	OPERATING INSTRUCTIONS..... 20
Chemical Vapor Corrosion..... 6	Adjustment Procedure (Initial Start-Up)..... 20
Venting..... 6	Cathodic Protection..... 21
Vent Pipe Termination..... 6-10	Precautions..... 21
Installation Requirements for the	GENERAL INFORMATION..... 21
Commonwealth of Massachusetts..... 7	Power Burner..... 21
Direct Venting..... 8	High Limit..... 21
Direct Vent Terminal Installation (Sidewall)..... 9	High Altitude Installations..... 21
Installation Sequence..... 9	MAINTENANCE..... 21
Vertical Vent Terminal Installation..... 10	General..... 21
Installation Sequence..... 10	Maintenance Schedule..... 21
Installation of Vent System..... 11	Flushing..... 23
Vent Pipe Preparation..... 11	Draining..... 23
CONTROL AND SWITCHES..... 12	Sediment Removal..... 23
Blower Prover Switch..... 12	Lime Scale Removal..... 23
Blocked Outlet Prover Switch..... 12	Anode Inspection and Replacement..... 23
Blocked Inlet Prover Switch..... 12	Drain Valve and Access Panels..... 24
Low Gas Pressure Switch..... 12	Relief Valve..... 24
On/Off Switch..... 12	Circulating Pump..... 24
Hot Surface Igniter..... 12	Vent System..... 24
GAS PIPING..... 12	INSTALLATION DIAGRAMS..... 25-29
Connection of Gas Pipe..... 13	Manifold Kits..... 30
Purging..... 14	CHECKLIST AND SERVICE INFORMATION..... 31
Gas Meter Size - City Gases Only..... 14	TROUBLE-SHOOTING..... 31,32
Gas Pressure Regulation..... 14	LIMITED WARRANTY..... 35

FEATURES

IMPORTANT

IT IS REQUIRED THAT A QUALIFIED SERVICE TECHNICIAN PERFORM THE INITIAL FIRING OF THE HEATER. AT THIS TIME THE USER SHOULD NOT HESITATE TO ASK THE TECHNICIAN ANY QUESTIONS WHICH HE MAY HAVE IN REGARD TO THE OPERATION AND MAINTENANCE OF THE UNIT.

A CHECKLIST AND SERVICE INFORMATION section are included at the rear of this manual. By using this checklist the user may be able to make minor operational adjustments and save himself unnecessary service calls. However, the user should not attempt repairs which are not listed in this section.

WATER TEMPERATURE CONTROL



⚠ DANGER

THIS WATER HEATER IS EQUIPPED WITH AN ADJUSTABLE THERMOSTAT TO CONTROL WATER TEMPERATURE. HOT WATER TEMPERATURES REQUIRED FOR AUTOMATIC DISHWASHER AND LAUNDRY USE CAN CAUSE SCALD BURNS RESULTING IN SERIOUS PERSONAL INJURY AND/OR DEATH. THE TEMPERATURE AT WHICH INJURY OCCURS VARIES WITH THE PERSON'S AGE AND THE TIME OF THE EXPOSURE. THE SLOWER RESPONSE TIME OF CHILDREN, AGED OR DISABLED PERSONS INCREASES THE HAZARDS TO THEM. NEVER ALLOW SMALL CHILDREN TO USE A HOT WATER TAP, OR TO DRAW THEIR OWN BATH WATER. NEVER LEAVE A CHILD OR DISABLED PERSON UNATTENDED IN A BATHTUB OR SHOWER.

THE WATER HEATER SHOULD BE LOCATED IN AN AREA WHERE THE GENERAL PUBLIC DOES NOT HAVE ACCESS TO SET TEMPERATURES.

The water temperature is controlled using the Temperature Control Button on the Display at the front of the unit (See Figure 1). This control utilizes two temperature probes to determine the tank temperature. The primary temperature probe is located at the top of the tank and the other is near the water inlet.

The temperature may be adjusted from 90°F/32°C to 180°F/82°C. The thermostat was adjusted to 120°F/49°C before the heater was shipped from the factory. It is recommended that lower water temperature be used to avoid the risk of scalding. It is further recommended, in all cases, that the water

temperature be set for the lowest temperature which satisfies your hot water needs. This will also provide the most energy efficient operation of the water heater and minimize scale formation.

SETTING THE WATER HEATER TEMPERATURE AT 120°F/49°C WILL REDUCE THE RISK OF SCALDS. Some states require settings at specific lower temperatures.

Figure 1 shows the approximate time-to-burn relationship for normal adult skin. Short repeated heating cycles caused by small hot water uses can cause temperatures at the point of use to exceed the thermostat setting by up to 20°F/11°C. If you experience this type of use, you should consider using lower temperature settings to reduce scald hazards.

Temperature Setting	Time to Produce 2nd & 3rd Degree Burns on Adult Skin
180°F / 82°C	Nearly instantaneous
170°F / 77°C	Nearly instantaneous
160°F / 71°C	About 1/2 second
150°F / 66°C	About 1-1/2 seconds
140°F / 60°C	Less than 5 seconds
130°F / 54°C	About 30 seconds
120°F / 49°C	More than 5 minutes

FIGURE 1.

Valves for reducing point-of-use temperature by mixing cold and hot water are available (see Figure 2). Also available are inexpensive devices that attach to faucets to limit hot water temperatures. Contact a licensed plumber or the local plumbing authority.

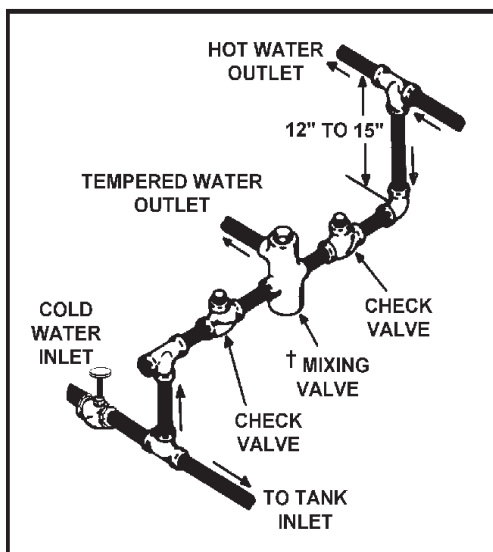

FIGURE 2.

HIGH LIMIT SWITCH (E.C.O.)

The top immersion well of the dual bulb controller also contains the high limit (energy cutoff) sensor. The high limit switch interrupts the main burner gas flow should the water temperature reach approximately 202°F/94°C.

Should the high limit switch activate, the control system will automatically reset the unit once the water temperature in the tank falls below 140°F/60°C. If the unit is manually shut down and restarted, as long as the temperature in the tank is lower than 160°F/71°C, the unit will reset and initiate operation.

High limit switch operation is the likely cause when higher than normal water temperatures occur with a recurring need to restart the water heater. This could be due to a malfunctioning thermostat allowing the gas valve to remain open and the burner to continue firing even after water temperature in the tank has already reached the set point. Contact your dealer or servicer if continued high limit switch operation occurs.

DISHWASHING MACHINE REQUIREMENT

All dishwashing machines meeting the National Sanitation Foundation requirements are designed to operate with water flow pressures between 15 and 25 pounds per square inch (103 Kpa and 173 Kpa). Flow pressures above 25 pounds per square inch (173 Kpa), or below 15 pounds per square inch (103 Kpa), will result in improperly sanitized dishes. Where pressures are high, a water pressure reducing or flow regulating control valve should be used in the 180°F (82°C) line to the dishwashing machine, and should be adjusted to deliver water between these limits.

The National Sanitation Foundation also recommends circulation of 180°F (82°C) water. Where this is done, the circulation should be very gentle so that it does not cause any unnecessary turbulence inside the water heater. The circulation should be just enough to provide 180°F (82°C) water at the point of take-off to the dishwashing machine. Adjust flow by means of the plug cock in the circulating line. (See installation diagrams.)

CIRCULATING PUMP

A circulating pump is used when a system requires a circulating loop or there is a storage tank used in conjunction with the heater. Refer to the piping diagrams at rear of manual for electrical hookup information and install in accordance with the current edition of the National Electrical Code, NFPA 70.

All bronze circulating pumps are recommended for used with commercial water heaters.

Although circulating pumps are oiled and operated by the manufacturer some circulating pumps must be oiled again before operated. Please refer to manufacturer's instructions.

INSTALLATION INSTRUCTIONS

REQUIRED ABILITY

INSTALLATION OR SERVICE OF THIS WATER HEATER REQUIRES ABILITY EQUIVALENT TO THAT OF A LICENSED TRADESMAN IN THE FIELD INVOLVED. PLUMBING, AIR SUPPLY, VENTING, GAS SUPPLY AND ELECTRICAL WORK ARE REQUIRED.

INSULATION BLANKETS

Insulation blankets available to the general public for external use on gas water heaters are not approved for use on your water heater. The purpose of an insulation blanket is to reduce the standby heat loss encountered with storage tank water heaters. Your water heater meets or exceeds the ASHRAE/IES 90.1 2004 standards with respect to insulation and standby loss requirements, making an insulation blanket unnecessary.

WARNING

Should you choose to apply an insulation blanket to this heater, you should follow these instructions. Failure to follow these instructions can result in fire, asphyxiation, serious personal injury or death.

- Do not apply insulation to the top, or the upper 15" (38 cm) of the water heater, as this will interfere with safe operation.
- Do not cover the temperature & pressure relief valve.
- Do not cover the instruction manual. Keep it on the side of the water heater or nearby for future reference.
- Do obtain new labels for placement on the blanket directly over the existing labels.

LOCATING THE HEATER

WARNING

THERE IS A RISK IN USING FUEL BURNING APPLIANCES SUCH AS GAS WATER HEATERS IN ROOMS, GARAGES OR OTHER AREAS WHERE GASOLINE, OTHER FLAMMABLE LIQUIDS OR ENGINE DRIVEN EQUIPMENT OR VEHICLES ARE STORED, OPERATED OR REPAIRED. FLAMMABLE VAPORS ARE HEAVY AND TRAVEL ALONG THE FLOOR AND MAY BE IGNITED BY THE HEATER'S IGNITER OR MAIN BURNER FLAMES CAUSING FIRE OR EXPLOSION. SOME LOCAL CODES PERMIT OPERATION OF GAS APPLIANCES IF INSTALLED 18 INCHES (46 cm) OR MORE ABOVE THE FLOOR. THIS MAY REDUCE THE RISK IF LOCATION IN SUCH AN AREA CANNOT BE AVOIDED.

THE HEATER SHOULD BE LOCATED OR PROTECTED SO IT IS NOT SUBJECT TO PHYSICAL DAMAGE BY A MOVING VEHICLE.

DO NOT LOCATE THE HEATER WHERE NOISE FROM THE EXHAUST OR INTAKE WILL BE OBJECTIONABLE. THIS INCLUDES LOCATIONS CLOSE TO OR ACROSS FROM WINDOWS AND DOORS. AVOID ANCHORING THE VENT AND INTAKE PIPES DIRECTLY TO FRAMED WALLS, FLOORS OF CEILINGS UNLESS RUBBER ISOLATION PIPE HANGERS ARE USED. THIS PREVENTS ANY VIBRATIONS FROM BEING TRANSMITTED INTO THE LIVING SPACES.

WARNING

FLAMMABLE ITEMS, PRESSURIZED CONTAINERS OR ANY OTHER POTENTIAL FIRE HAZARDOUS ARTICLES MUST NEVER BE PLACED ON OR ADJACENT TO THE HEATER. OPEN CONTAINERS OF FLAMMABLE MATERIAL SHOULD NOT BE STORED OR USED IN THE SAME ROOM WITH THE HEATER.

When installing the heater, consideration must be given to proper location. Location selected should be as close to the intake and exhaust termination points as practicable, with adequate air supply and as centralized with the piping system as possible.

THE HEATER MUST NOT BE LOCATED IN AN AREA WHERE IT WILL BE SUBJECT TO FREEZING.

LOCATE IT NEAR A FLOOR DRAIN. THE HEATER SHOULD BE LOCATED IN AN AREA WHERE LEAKAGE FROM THE HEATER OR CONNECTIONS WILL NOT RESULT IN DAMAGE TO THE ADJACENT AREA OR TO LOWER FLOORS OF THE STRUCTURE.

When such locations cannot be avoided, it is recommended that a suitable metal drain pan, adequately drained, be installed under the appliance.

Water heater life depends upon water quality, water pressure and the environment in which the water heater is installed. Water heaters are sometimes installed in locations where leakage may result in property damage, even with the use of a drain pan piped to a drain. However, unanticipated damage can be reduced or prevented by a leak detector or water shut-off device used in conjunction with a piped metal drain pan. These devices are available from some plumbing supply wholesalers and retailers, and detect and react to leakage in various ways:

- Sensors mounted in the drain pan that trigger an alarm or turn off the incoming water to the water heater when leakage is detected.
- Sensors mounted in the drain pan that turn off the water supply to the entire home when water is detected in the drain pan.
- Water supply shut-off devices that activate based on the water pressure differential between the cold water and hot water pipes connected to the water heater.
- Devices that will turn off the gas supply to a gas water heater while at the same time shutting off its water supply.

WARNING

THIS WATER HEATER IS A CONDENSING UNIT AND REQUIRES A DRAIN TO BE LOCATED IN CLOSE PROXIMITY TO ALLOW THE CONDENSATE TO DRAIN SAFELY. THE CONDENSATE DRAINS FROM THE UNIT AT THE EXHAUST ELBOW LOCATED AT THE BOTTOM OF THE UNIT. NOTE: IT IS IMPORTANT THAT THE CONDENSATE HOSE NOT BE ELEVATED ABOVE THE EXHAUST ELBOW (SEE FIGURE 3). THE CONDENSATE BUILD-UP WILL BLOCK THE EXHAUST OUTLET, WHICH WILL CAUSE IMPROPER OPERATION.

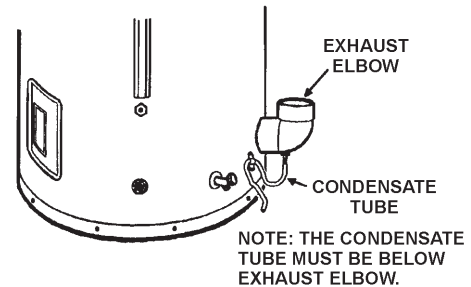

FIGURE 3.

WARNING

DO NOT USE THIS APPLIANCE IF ANY PART HAS BEEN UNDER WATER. IMMEDIATELY CALL A QUALIFIED SERVICE TECHNICIAN TO INSPECT THE APPLIANCE AND TO REPLACE ANY PART OF THE CONTROL SYSTEM AND ANY GAS CONTROL WHICH HAS BEEN UNDER WATER.

CLEARANCES

These heaters are approved for installation on combustible flooring in an alcove when the minimum clearances from any combustible materials are followed as indicated in Figure 4.

In all installations the minimum combustible clearances from any vent piping should be 0". Vent piping passing through a combustible wall or ceiling must be a continuous run (no joints).

A service clearance of 24" (61 cm) should be maintained from serviceable parts such as relief valves, flue baffles, flue damper devices, thermostats, cleanout openings or drain valves.

Always disconnect electrical power before servicing the unit.

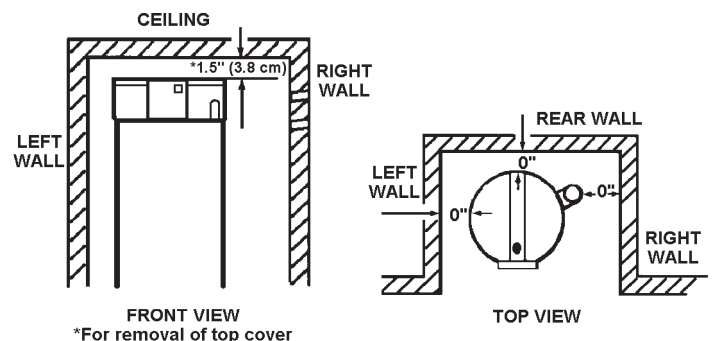

FIGURE 4.

*ILLUSTRATION OF MINIMUM COMBUSTIBLE CLEARANCES IN AN ALCOVE.

HARD WATER

Where hard water conditions exist, water softening or the threshold type of water treatment is recommended. This will protect the dishwashers, coffee urns, water heaters, water piping and other equipment.

See MAINTENANCE section for details of tank cleanout procedure.

AIR REQUIREMENTS

KEEP APPLIANCE AREA CLEAR AND FREE OF COMBUSTIBLE MATERIALS, GASOLINE AND OTHER FLAMMABLE VAPORS AND LIQUIDS.

DO NOT OBSTRUCT THE FLOW OF COMBUSTION AND VENTILATING AIR.

WARNING

FOR SAFE OPERATION PROVIDE ADEQUATE AIR FOR COMBUSTION AND VENTILATION. AN INSUFFICIENT SUPPLY OF AIR WILL CAUSE RECIRCULATION OF COMBUSTION PRODUCTS RESULTING IN CONTAMINATION THAT MAY BE HAZARDOUS TO LIFE. SUCH A CONDITION OFTEN WILL RESULT IN A YELLOW, LUMINOUS BURNER FLAME, CAUSING CARBONING OR SOOTING OF THE COMBUSTION CHAMBER, BURNERS AND FLUE TUBES AND CREATES A RISK OF ASPHYXIATION.

MECHANICAL EXHAUSTING OF ROOM AIR

Where an exhaust fan is installed in the same room with a heater, sufficient openings for air must be provided in the walls. **UNDERSIZED OPENINGS WILL CAUSE AIR TO BE DRAWN INTO THE ROOM THROUGH THE HEATER'S VENTING SYSTEM, CAUSING POOR COMBUSTION. SOOTING MAY RESULT IN SERIOUS DAMAGE TO THE HEATER AND RISK OF FIRE OR EXPLOSION. IT CAN ALSO CREATE A RISK OF ASPHYXIATION.**

UNCONFINED SPACE

In buildings of conventional frame, brick or stone construction, unconfined spaces may provide adequate air for combustion and ventilation.

If the unconfined space is within a building of tight construction (buildings using the following construction: weather stripping, heavy insulation, caulking, vapor barrier, etc.), air for combustion and ventilation must be obtained from outdoors. The installation instructions for confined spaces in tightly constructed buildings must be followed to ensure adequate air supply.

CONFINED SPACE

When drawing combustion air from inside a conventionally constructed building to a confined space, such a space should be provided with two permanent openings, ONE IN OR WITHIN 12" (31 cm) OF THE ENCLOSURE TOP AND ONE IN OR WITHIN 12" (31 cm) OF THE ENCLOSURE BOTTOM. Each opening should have a free area of at least one square inch (6.5 cm²) per 1000 Btuh appliances in the enclosure, but not less than 100 square inches (645 cm²).

If the confined space is within a building of tight construction, air for combustion and ventilation must be obtained from outdoors. When directly communicating with the outdoors through vertical ducts, two permanent openings, located in the above manner, should be provided. Each opening should have a free area of not less than one square inch (6.5 cm²) per 4000 Btuh of the total input of all appliances in the enclosure. If horizontal ducts are used, each opening should have a free area of not less than one square inch (6.5 cm²) per 2000 Btuh of the total input of all appliances in the enclosure.

CHEMICAL VAPOR CORROSION

WARNING

CORROSION OF THE FLUE WAYS AND VENT SYSTEM MAY OCCUR IF AIR FOR COMBUSTION CONTAINS CERTAIN CHEMICAL VAPORS. SUCH CORROSION COULD RESULT IN FAILURE AND RISK OF ASPHYXIATION.

Spray can propellants, cleaning solvents, refrigerator and air conditioning refrigerants, swimming pool chemicals, calcium and sodium chloride, waxes, and process chemicals are typical compounds which are potentially corrosive.

PRODUCTS OF THIS SORT SHOULD NOT BE STORED NEAR THE HEATER. ALSO, AIR WHICH IS BROUGHT IN CONTACT WITH THE HEATER SHOULD NOT CONTAIN ANY OF THESE CHEMICALS. IF NECESSARY, UNCONTAMINATED AIR SHOULD BE OBTAINED FROM REMOTE OR OUTSIDE SOURCES.

VENTING

WARNING

THE INSTRUCTIONS IN THIS SECTION ON VENTING MUST BE FOLLOWED TO AVOID CHOKED COMBUSTION OR RECIRCULATION OF FLUE GASES. SUCH CONDITIONS CAUSE SOOTING OR RISKS OF FIRE AND ASPHYXIATION.

Heater must be protected from freezing downdrafts during shutdown periods.

WARNING

NEVER OPERATE THE HEATER UNLESS IT IS VENTED TO THE OUTDOORS AND HAS ADEQUATE AIR SUPPLY TO AVOID RISKS OF IMPROPER OPERATION, FIRE, EXPLOSION OR ASPHYXIATION.

VENT PIPE TERMINATION

NOTE: Before installing venting, determine place of vent pipe termination. See Figures 5 and 6 before proceeding.

CAUTION

DO NOT TERMINATE THE VENTING WHERE NOISE FROM THE EXHAUST OR INTAKE WILL BE OBJECTIONABLE. THIS INCLUDES LOCATIONS CLOSE TO OR ACROSS FROM WINDOWS AND DOORS. AVOID ANCHORING THE VENT AND INTAKE PIPES DIRECTLY TO FRAMED WALLS, FLOORS OR CEILINGS UNLESS RUBBER ISOLATION PIPE HANGERS ARE USED. THIS PREVENTS ANY VIBRATIONS FROM BEING TRANSMITTED INTO THE LIVING SPACES.

INSTALLATION REQUIREMENTS FOR THE COMMONWEALTH OF MASSACHUSETTS

For all side wall terminated, horizontally vented power vent, direct vent, and power direct vent gas fueled water heaters installed in every dwelling, building or structure used in whole or in part for residential purposes, including those owned or operated by the Commonwealth and where the side wall exhaust vent termination is less than seven (7) feet above finished grade in the area of the venting, including but not limited to decks and porches, the following requirements shall be satisfied:..

INSTALLATION OF CARBON MONOXIDE DETECTORS At the time of installation of the side wall horizontal vented gas fueled equipment, the installing plumber or gasfitter shall observe that a hard wired carbon monoxide detector with an alarm and battery back-up is installed on the floor level where the gas equipment is to be installed. In addition, the installing plumber or gasfitter shall observe that a battery operated or hard wired carbon monoxide detector with an alarm is installed on each additional level of the dwelling, building or structure served by the sidewall horizontal vented gas fueled equipment. It shall be the responsibility of the property owner to secure the services of qualified licensed professionals for the installation of hard wired carbon monoxide detectors.

In the event that the side wall horizontally vented gas fueled equipment is installed in a crawl space or an attic, the hard wired carbon monoxide detector with alarm and battery back-up may be installed on the next adjacent floor level.

In the event that the requirements of this subdivision can not be met at the time of completion of installation, the owner shall have a period of thirty (30) days to comply with the above requirements provided that during said thirty (30) day period, a battery operated carbon monoxide detector with an alarm shall be installed.

APPROVED CARBON MONOXIDE DETECTORS Each carbon monoxide detector as required in accordance with the above provisions shall comply with NFPA 720 and be ANSI/UL 2034 listed and CSA certified.

SIGNAGE A metal or plastic identification plate shall be permanently mounted to the exterior of the building at a minimum height of eight (8) feet above grade directly in line with the exhaust vent terminal for the horizontally vented gas fueled heating appliance or equipment. The sign shall read, in print size no less than one-half (1/2) inch in size, **"GAS VENT DIRECTLY BELOW. KEEP CLEAR OF ALL OBSTRUCTIONS."**

INSPECTION The state or local gas inspector of the side wall horizontally vented gas fueled equipment shall not approve the installation unless, upon inspection, the inspector observes carbon monoxide detectors and signage installed in accordance with the provisions of 248 CMR 5.08(2)(a) 1 through 4.

EXEMPTIONS: The following equipment is exempt from 248 CMR 5.08(2)(a)1 through 4:

1. The equipment listed in Chapter 10 entitled "Equipment Not Required To Be Vented" in the most current edition of NFPA 54 as adopted by the Board; and
2. Product Approved side wall horizontally vented gas fueled equipment installed in a room or structure separate from the dwelling, building, or structure used in whole or in part for residential purposes.

MANUFACTURER REQUIREMENTS - GAS EQUIPMENT VENTING SYSTEM PROVIDED When the manufacturer of Product Approved side wall horizontally vented gas equipment provides a venting system design or venting system components with the equipment, the instructions provided by the manufacturer for installation of the equipment and the venting system shall include:

1. Detailed instructions for the installation of the venting system design or the venting system components; and
2. A complete parts list for the venting system design or venting system.

MANUFACTURER REQUIREMENTS - GAS EQUIPMENT VENTING SYSTEM NOT PROVIDED When the manufacturer of a Product Approved side wall horizontally vented gas fueled equipment does not provide the parts for venting the flue gases, but identifies "special venting systems," the following requirements shall be satisfied by the manufacturer:

1. The referenced "special venting system" instructions shall be included with the appliance or equipment installation instructions; and
2. The "special venting systems" shall be Product Approved by the Board, and the instructions for that system shall include a parts list and detailed installation instructions.

A copy of all installation instructions for all Product Approved side wall horizontally vented gas fueled equipment, all venting instructions, all parts lists for venting instructions, and/or all venting design instructions shall remain with the appliance or equipment at the completion of the installation.

WARNING
VENT HOOD(S) MAY
BE EXTREMELY HOT
DURING OPERATION

U.S. POWER VENT

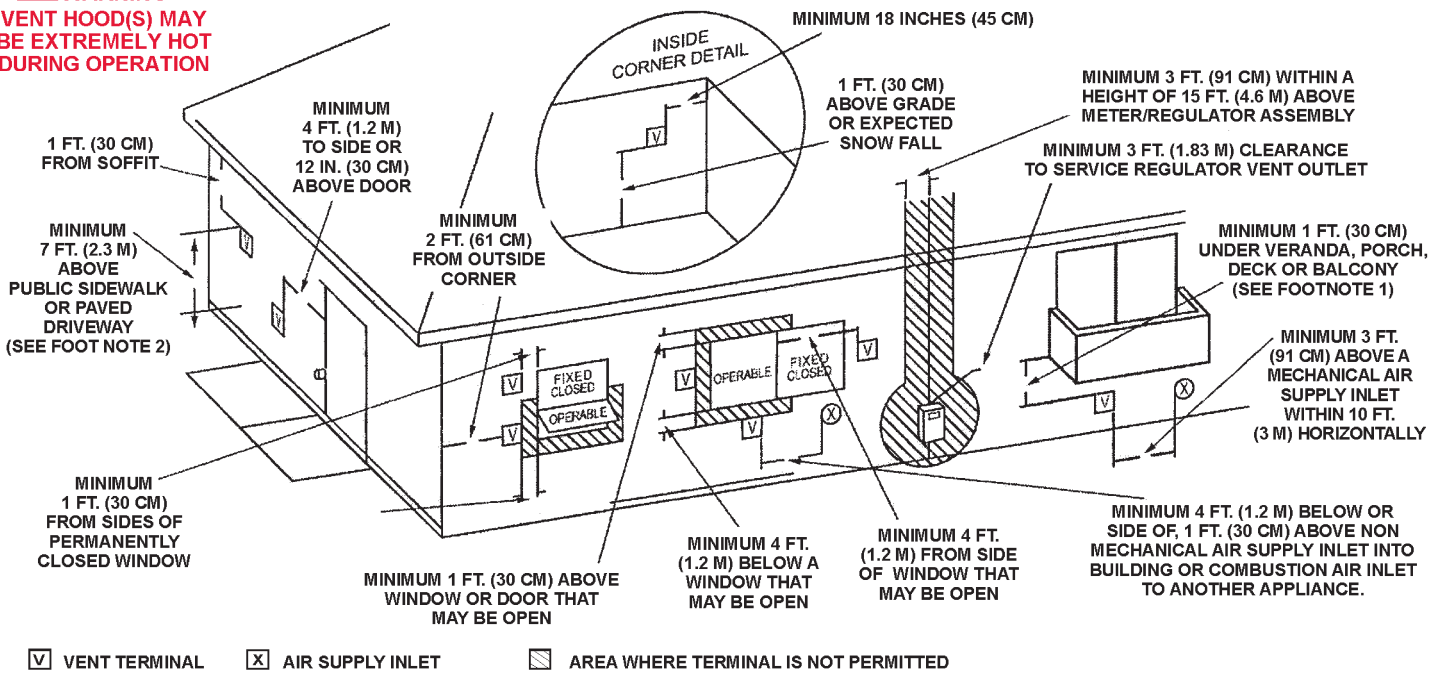

1. PERMITTED ONLY IF VERANDA, PORCH, DECK OR BALCONY IS FULLY OPENED ON A MINIMUM OF TWO SIDES BENEATH THE FLOOR.
2. A VENT SHALL NOT TERMINATE ABOVE A SIDEWALK OR PAVED DRIVEWAY THAT IS LOCATED BETWEEN TWO SINGLE FAMILY FWEELLINGS AND SERVES BOTH DWELLINGS.

FIGURE 5.

CAUTION
TO PREVENT EXHAUSTING PRODUCTS FROM CIRCULATING TO THE AIR INTAKE IN WINDY/COLD
AREAS, THE MAXIMUM PRACTICAL DISTANCE BETWEEN THESE TWO TERMINALS IS RECOMMENDED.

WARNING
VENT HOOD(S) MAY
BE EXTREMELY HOT
DURING OPERATION

U.S. DIRECT VENT

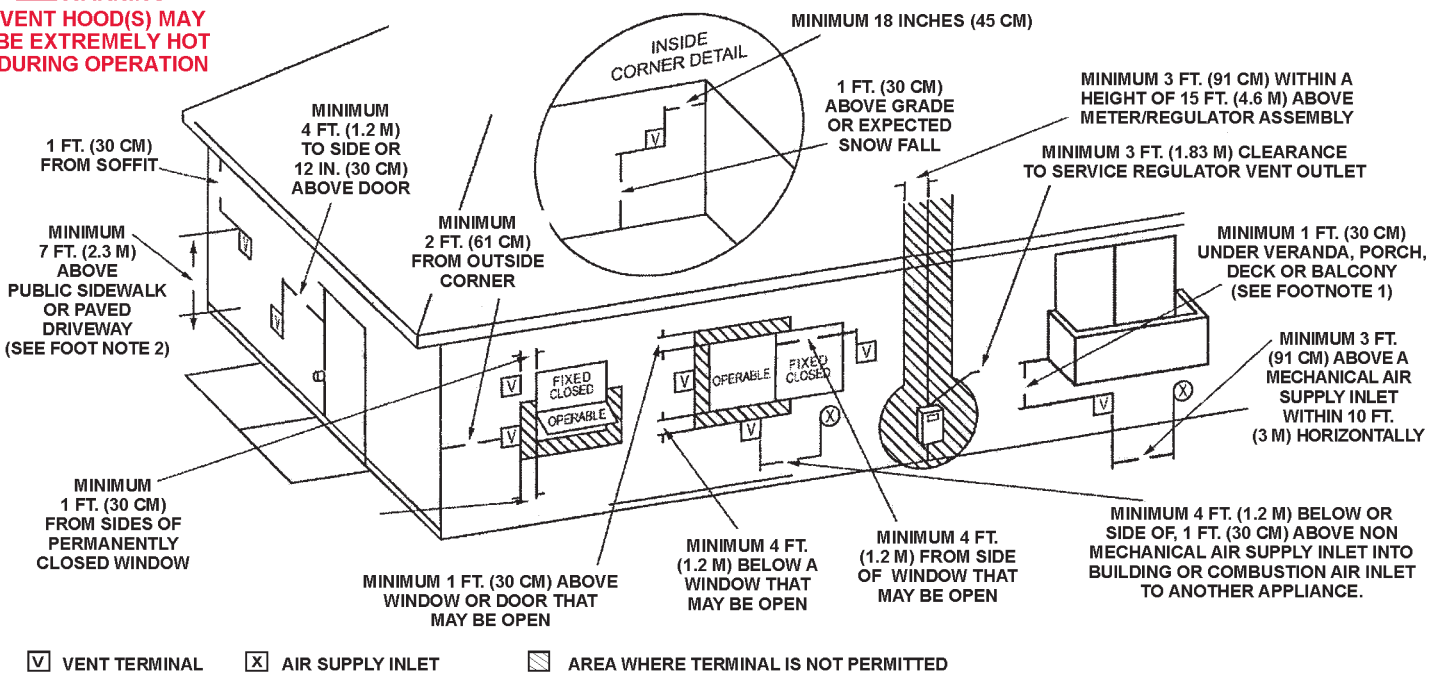

1. PERMITTED ONLY IF VERANDA, PORCH, DECK OR BALCONY IS FULLY OPENED ON A MINIMUM OF TWO SIDES BENEATH THE FLOOR.
2. A VENT SHALL NOT TERMINATE ABOVE A SIDEWALK OR PAVED DRIVEWAY THAT IS LOCATED BETWEEN TWO SINGLE FAMILY FWEELLINGS AND SERVES BOTH DWELLINGS.

FIGURE 6.

CAUTION
TO PREVENT EXHAUSTING PRODUCTS FROM CIRCULATING TO THE AIR INTAKE IN WINDY/COLD
AREAS, THE MAXIMUM PRACTICAL DISTANCE BETWEEN THESE TWO TERMINALS IS RECOMMENDED.

IMPORTANT

The vent system must terminate so that proper clearances are maintained as cited in local codes or the current editions of the National Fuel Gas Code, ANSI Z223.1/NFPA 54.

Do not terminate the exhaust vent terminal over public area where condensate or vapor can cause nuisance or hazard.

Plan the vent system layout so that proper clearances are maintained from plumbing and wiring.

Vent pipes serving power vented appliances are classified by building codes as "vent connectors". Required clearances from combustible materials must be provided in accordance with information in this manual under LOCATION OF HEATER and CLEARANCES, and with National Fuel Gas Code and local Codes.

IMPORTANT

Plan the layout of the vent system backwards from the vent termination to the appliance.



WARNING

USE ONLY THE VENT TERMINALS SUPPLIED WITH THIS UNIT. TERMINATION OF A VENT SYSTEM WITH A DEVICE OTHER THAN THE SUPPLIED VENT TERMINATIONS WILL AFFECT SYSTEM PERFORMANCE AND RESULT IN A SAFETY HAZARD.

DIRECT VENTING

The air intake provided on the unit contains a mesh screen (see Figure 7) to prevent large particles from entering the unit.

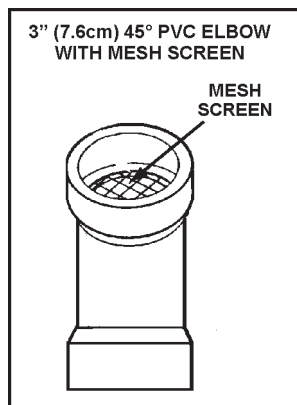

FIGURE 7.



WARNING

WHEN THE UNIT IS TO BE SETUP AS A DIRECT VENT, THE MESH SCREEN MUST BE REMOVED. THE INLET VENT PIPE MAY THEN BE GLUED TO THE AIR INTAKE (see Figure 8) PROVIDED ON THE UNIT.

DIRECT VENT TERMINAL INSTALLATION

IMPORTANT

THIS UNIT CONSISTS OF TWO VENT TERMINALS - AN INTAKE VENT TERMINAL AND AN EXHAUST VENT TERMINAL. THE INTAKE VENT TERMINAL IS A 3" 45° PVC ELBOW WITH A DOME MESH WIRE SCREEN AND THE EXHAUST VENT TERMINAL IS A 3" 45° PVC ELBOW WITH A MESH WIRE SCREEN.

NOTE: TO PREVENT EXHAUSTING PRODUCTS FROM CIRCULATING TO THE AIR INTAKE IN WINDY/COLD AREAS, THE MAXIMUM PRACTICAL DISTANCE BETWEEN THESE TWO TERMINALS IS RECOMMENDED

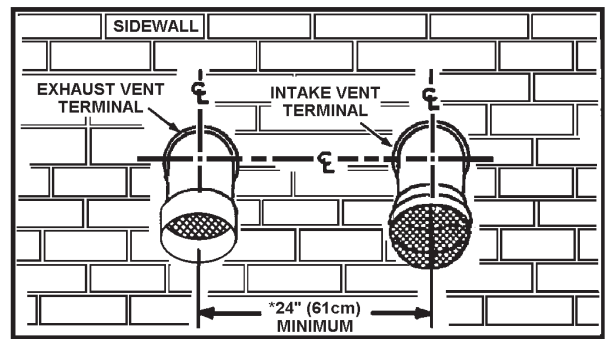

FIGURE 8.

IMPORTANT

WHEN LOCATING THE TERMINALS ON A SIDEWALL, THE FOLLOWING SPECIFICATIONS PERTAINING TO TERMINAL LOCATION MUST BE FOLLOWED.

1. The intake vent terminal and the exhaust vent terminal must terminate on the same exterior wall and must be located at a minimum of 24" (61cm) from the vertical centerline of the exhaust vent terminal (see Figure 9). In colder climates increasing the 24" (61cm) minimum will reduce possibility of frost over from side winds blowing exhaust vapors to the air intake of the direct vent.
2. The horizontal centerline of the intake vent terminal may not be located lower than the horizontal centerline of the exhaust vent terminal (see Figure 9).

INSTALLATION SEQUENCE

For installations in the City of Los Angeles, California Category IV PVC Pipe such as that manufactured by Brownline Pipe Company, must be used as vent pipe material



CAUTION

Vent terminals supplied with the heater must be used.

NOTE: BEFORE BEGINNING INSTALLATION OF ANY VENT PIPE READ THE VENT PIPE MANUFACTURER'S INSTALLATION INSTRUCTIONS.

1. After the points of termination have been determined, use the cover plates as templates to mark the holes for the vent pipes to be inserted through the wall. BEWARE OF CONCEALED WIRING AND PIPING INSIDE OF WALL.
2. If the vent terminals are being installed on the outside of a finished wall, it may be easier to mark both the inside and outside wall. Align the holes by drilling a hole through the center of the template from the inside through to the outside. The template can now be positioned on the outside wall using the drilled holes as a centering point for the template.
3. A) MASONRY SIDE WALLS
Chisel an opening approximately 1/2" (1.3 cm) larger than the marked circle.
B) WOODEN SIDE WALLS
Drill a pilot hole approximately one quarter inch outside of the marked circle. This pilot hole is used as a starting point for a saws-all or sabre saw blade. Cut around the marked circle staying approximately one quarter inch outside of the line. (This will allow the vent pipe to easily slide through the opening. The resulting gap will be covered by the vent terminal cover plates.) Repeat this step on the inside wall if necessary.
4. Cut a length of 3" PVC pipe about 3.5" (8.9 cm) longer than the wall thickness at the opening.

5. Glue the intake vent terminal to the section of the pipe.
6. Slide the wall plate over the pipe to stop against intake vent terminal.
7. Place a bead of caulking (not supplied) around the gap between the pipe and the wall. Place some of the caulking on the back of the plate to hold it against the wall after installation.
8. If the vent pipe is installed up to the wall, with a coupling on the end against the wall opening, the pipe with the vent terminal can be prepared for gluing before inserting through the wall. Slide the pipe through the wall and insert into coupling on the other side of the wall, making sure that the vent terminal ends up pointed in the correct position (See Figure 9).

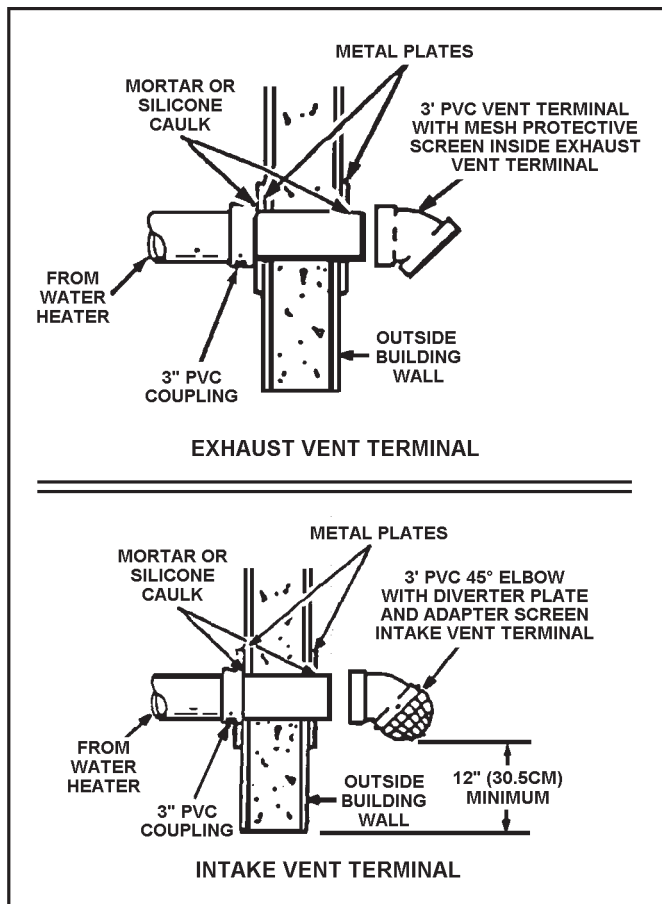

FIGURE 9.

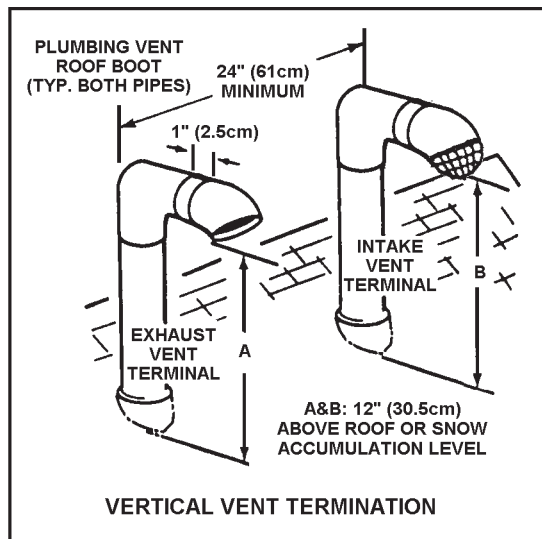

FIGURE 10.

VERTICAL VENT TERMINAL INSTALLATION

IMPORTANT

WHEN TERMINATING THROUGH A ROOF, THE FOLLOWING SPECIFICATIONS PERTAINING TO TERMINAL LOCATION MUST BE FOLLOWED.

1. Proper support must be provided for all pipe protruding through the roof.
2. The vertical roof terminations should be sealed with a plumbing roof boot or equivalent flashing.
3. The intake vent termination and the exhaust vent termination must penetrate the same side of roof.
4. The center line of the intake vent termination and the center line of the exhaust vent termination must be no closer than 24" (61cm).
5. The intake vent terminal and the exhaust vent terminal must be oriented facing downward and the same direction.

The specifications are displayed in Figure 10 & 11.

NOTE: Exhaust vent terminal is installed using the same procedure.

INSTALLATION SEQUENCE

NOTE: BEFORE BEGINNING INSTALLATION OF ANY VENT PIPE, READ "VENT PIPE PREPARATION" SECTION ON PAGE 12.

1. After the points of termination have been determined, use the cover plates as templates to mark the holes for the vent pipes to be inserted through the roof.
2. Drill a pilot hole approximately 1/4" (6 mm) outside of the marked circle. This pilot hole is used as a starting point for a saws-all or sabre saw blade. Cut around the marked circle staying approximately one quarter inch outside the line. (This will allow the vent pipe to easily slide through the opening). The resulting gap will be covered by the roof boot/flashing.
3. Suspend the pipe through the center of the hole using proper support.
4. Slide roof boot or equivalent flashing over pipe and secure roof boot equivalent flashing to roof.
5. Seal around flashing.
6. Terminate intake terminal and exhaust vent terminal facing down as shown in Figure 11.

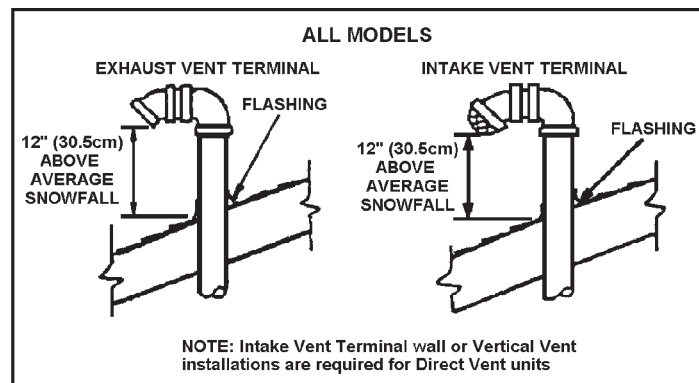

FIGURE 11.

INSTALLATION OF VENT SYSTEM

WARNING

THE OPTIONAL INTAKE VENTING ARRANGEMENT AND THE EXHAUST VENTING ARRANGEMENT MUST BE INSTALLED TO RUN DIRECTLY TO THE OUTDOORS AND NOT IN ANY WAY BE CONNECTED TO ANOTHER VENTING SYSTEM (I.E. FURNACE, DRYERS OR SPACE HEATERS). IT IS CRUCIAL THAT THE VENTING ARRANGEMENT BE KEPT SEPARATE FROM OTHER VENTING SYSTEMS. IF THIS WARNING IS IGNORED, AND THE SYSTEM IS VENTED INCORRECTLY, IT COULD CAUSE IMPROPER OPERATION, FIRE, EXPLOSION, OR ASPHYXIATION.

1. Plan the route of the vent system from the vent termination to the planned location of the appliance. Layout the total vent system to use the minimum of vent pipe and elbows possible.
2. The installer may add up to a MAXIMUM OF FIFTY (50) EQUIVALENT FEET (15.2 m) of pipe to the exhaust venting arrangement. This addition of FIFTY (50) EQUIVALENT FEET (15.2 m) of pipe on both the intake venting arrangement and exhaust venting arrangement must include any 3" PVC elbows which equals (5) EQUIVALENT FEET (1.5 m) of pipe.

Table 2. VENT LENGTH TABLE

Number of 90° Elbows	3" Minimum Pipe (Ft./M.)	3" Maximum Pipe (Ft./M.)	4" Maximum Pipe (Ft./M.)
ONE (1)	7/2	45/13.7	115/35
TWO (2)	7/2	40/12.2	110/33.5
THREE (3)	7/2	35/10.7	105/32
FOUR (4)	7/2	30/9.1	100/30.5
FIVE (5)	7/2	---	95/29
SIX (6)	7/2	---	90/27.4

4" PVC may be used for a MAXIMUM intake of ONE HUNDRED TWENTY (120) EQUIVALENT FEET (36.6m) and a MAXIMUM exhaust of ONE HUNDRED TWENTY (120) EQUIVALENT FEET (36.6m). The maximum number of 90° elbows with the 4" venting is six (6) on the intake and six (6) on the exhaust. A 90° elbow is equal to five (5) equivalent feet (1.5m) of pipe. One (1) 90° elbow is equal to two (2) 45° elbows. Any venting configuration using less than 50 equivalent feet should use 3" venting. See Table 2.

The 3" venting terminals (provided) must be used with the 3" vent pipe. Two, approved 4" vent terminals (not provided) must be used with 4" vent pipe. See replacement parts list for terminals.

IMPORTANT

When multiple units are direct vented through a wall (3" or 4" venting), all intake vent terminals should be no lower than the highest exhaust vent terminal.

NOTE: This unit can be vented using only PVC (Class 160, ASTM D-2241 Schedule 40, ASTM D-1785 ; or Cellular Core Schedule 40 DWV, ASTM F-891) , Schedule 40 CPVC (ASTM F-411), or ABS (ASTM D-2661) pipe. The fittings, other than the TERMINATIONS should be equivalent to PVC-DWV fittings meeting ASTM D-2665 (Use CPVC fittings, ASTM F-438 for CPVC pipe and ABS fittings, ASTM D-2661/3311 for ABS pipe. If CPVC or ABS pipe and fittings are used, then the proper cement must be used for all joints, including joining the pipe to the Termination (PVC Material). PVC Materials should use ASTM D-2564 Grade Cement; CPVC Materials should use ASTM F-493 Grade Cement and ; ABS Materials should use ASTM D-2235 Grade Cement.

NOTE: for Water Heaters in locations with high ambient temperatures (above 100°F or 38°C) and/or insufficient dilution air, it is recommended that CPVC or ABS pipe and fittings (**MUST USE SUPPLIED VENT TERMINAL**) be used.

4. It is important that condensate not be allowed to buildup in the exhaust vent pipe. To prevent this from happening the pipe should be installed with a slight, 1/8" (3mm) per 5' (152 cm) of pipe maximum downward slope.
5. The vent system should be supported every 5' (152 cm) of vertical run and every 3' (91cm) of horizontal run of vent pipe length.

NOTE: Stress levels in the pipe and fittings can be significantly increased by improper installation. If rigid pipe clamps are used to hold the pipe in place, or if the pipe cannot move freely through a wall penetration, the pipe may be directly stressed, or high thermal stresses may be formed when the pipe heats up and expands. Install accordingly to minimize such stresses.

VENT PIPE PREPARATION

1. INITIAL PREPARATION

- A. Make sure the solvent cement you are planning to use is designed for the specific application you are attempting.
- B. Know the physical and chemical characteristics and limitations of the PVC, PVC cellular core, ABS or CPVC piping materials that you are about to use.
- C. Know the reputation of your pipe and cement manufacturer and their products.
- D. Know your own qualifications or those of your contractor. The solvent welding technique of joining PVC, PVC cellular core, ABS or CPVC pipe is a specialized skill just as any other pipe fitting technique.
- E. Closely supervise the installation and inspect the finished job before start-up.
- F. Contact the manufacturer, supplier, or competent consulting agency if you have any questions about the application or installation of PVC, PVC cellular core, ABS or CPVC pipe.
- G. Take the time and effort to do a professional job. Shortcuts will only cause you problems and delays in start-up. The majority of failures in these systems are the result of shortcuts and/or improper joining techniques.

2. SELECTION OF MATERIALS

PRIMER

It is recommended that Tetrahydrofuran (THF) be used to prepare the surfaces of pipe and fittings for solvent welding. Do not use water, rags, gasoline or any other substitutes for cleaning PVC cellular core, ABS or CPVC surfaces. A chemical cleaner such as MEK may be used.

CEMENT

The cement should be a bodied cement of approximately 500 to 1600 centipoise viscosity containing 10-20% (by weight) virgin PVC material solvated with tetrahydrofuran (THF). Small quantities of dimethyl formamide (DMF) may be included to act as a retarding agent to extend curing time. Select the proper cement; Schedule 40 cement should be used for Schedule 40 pipe. Never use all-purpose cements, commercial glues and adhesives or ABS cement to join PVC or CPVC pipe and fittings.

SAFETY PRECAUTION: PRIMERS AND CEMENTS ARE EXTREMELY FLAMMABLE AND MUST NOT BE STORED OR USED NEAR HEAT OR OPEN FLAME. ALSO, USE ONLY IN A WELL-VENTILATED AREA.

CONTROLS AND SWITCHES

All models are provided with four pressure switches. These switches are essential to the safe and proper operation of the unit. All switches are wired in series. The controller is set up to shut the unit down whenever there is a failure of any of the switches. It is important to understand the purpose of each switch.

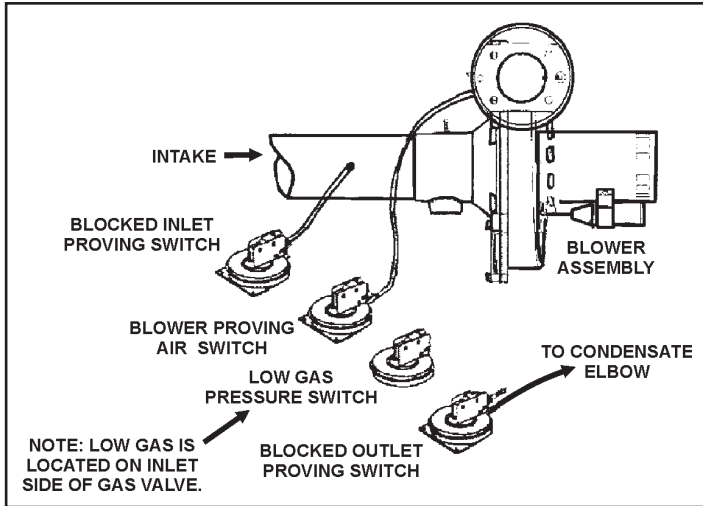

FIGURE 12.

BLOWER PROVER SWITCH

(SEE FIGURE 12)

The Blower Prover Switch is provided on the heater to verify that the fan is operating. It is a positive pressure switch whose electrical contacts are normally open. When the fan increases the pressure in the burner, the pressure switch will allow the electrical contacts to close. The pressure switch is connected to the burner tap by a piece of tygon tubing. This tubing must be connected in order for the switch to change the electrical contacts. The controller requires that the electrical contacts on this air flow switch be open before it will allow the blower to come on.

BLOCKED OUTLET PROVER SWITCH

(SEE FIGURE 12)

The Blocked Outlet Prover Switch is set up to shut the unit off when a build-up of positive pressure in the exhaust vent pipe occurs. This switch is a positive pressure switch that requires an increase in pressure to change the electrical contacts from normally closed to open. When this switch prevents the unit from igniting, most likely the exhaust is blocked by some means. Check to see if the condensate is allowed to flow freely from the exhaust elbow and for obstructions in the exhaust venting and exhaust vent terminal. Also verify that there is no more than fifty equivalent feet (15.2 m) of three inch PVC vent pipe on the exhaust.

BLOCKED INLET PROVER SWITCH

(SEE FIGURE 12)

The Blocked Inlet Prover Switch is set up to shut the unit off when a build-up of negative pressure in the intake vent pipe occurs. This switch is a negative pressure switch that requires an increase in negative pressure to change the electrical contacts from normally closed to open. The switch is connected to the pressure tap on the PVC flange connected to the inlet of the blower. When this switch prevents the unit from igniting, most likely the intake is blocked by some means. Check to see if there is no more than fifty equivalent feet (15.2 m) of three inch PVC vent pipe on the intake. Also verify that the intake and intake vent terminal is free of obstructions that may prevent air from entering the unit.

LOW GAS PRESSURE SWITCH

(SEE FIGURE 12)

The Low Gas Switch (LGS) is a single-pole, normally open pressure switch that will close its contacts when a rising pressure of 5.0 in. (1.25Kpa) W.C. is encountered. The contacts will open when the pressure falls below the fixed set point of 4.8"WC (1.18Kpa) for natural gas models and 8.5"WC (2.08Kpa) for propane models. The LGS monitors the gas supply pressure to the heater. If the gas supply falls below 5.0 in. (1.25Kpa) W.C., the main burner is extinguished (if heater is running) or the heater will not start up.

ON/OFF SWITCH

The ON/OFF Switch is a single-pole, single-throw rocker switch. This switch provides 120V from the line source to the heater.



CAUTION
THE WATER HEATER IS POLARITY SENSITIVE. BEFORE APPLYING ELECTRICITY TO THIS HEATER BE CERTAIN THAT SUPPLY NEUTRAL WIRE TO GROUND CHECK INDICATES ZERO VOLTAGE.

HOT SURFACE IGNITER

The Hot Surface Igniter is a device that ignites the main burner by high temperature (>1800°F or >982°C). When 120VAC is applied to the igniter, sufficient heat is generated to ignite the main burner. Although improvements have been made to strengthen the igniter, it is still fragile and care must be taken when handling the igniter to prevent breakage.

GAS PIPING

Contact your local gas service company to ensure that adequate gas service is available and to review applicable installation codes for your area.

Size the main gas line in accordance with Table 3. The figures shown are for straight lengths of pipe at 0.5" (125Pa) W.C. pressure drop, which is considered normal for low pressure systems. Note that fittings such as elbows and tees will add to the pipe pressure drop.



CAUTION
DO NOT USE FLEXIBLE GAS PIPING.

TABLE 3. MAXIMUM CAPACITY OF PIPE IN CUBIC FEET OF GAS PER HOUR

(Based upon a Pressure Drop of 0.5" Water Column and 0.6 Specific Gravity Gas and max. gas pressure of 0.5 psig)

LENGTH IN FEET	NORMAL IRON PIPE SIZES (INCHES) INPUT IN THOUSANDS BTU/HR								
	1/2"	3/4"	1"	1 1/4"	1 1/2"	2"	2 1/2"	3"	4"
10	175	360	680	1400	2100	3960	6300	11000	23000
20	120	250	485	950	1460	2750	4360	7700	15800
30	97	200	375	770	1180	2200	3520	6250	12800
40	82	170	320	660	990	1900	3000	5300	10900
50	73	151	285	580	900	1680	2650	4750	9700
60	66	138	260	530	810	1520	2400	4300	8800
70	61	125	240	490	750	1400	2250	3900	8100
80	57	118	220	460	690	1300	2050	3700	7500
90	53	110	205	430	650	1220	1950	3450	7200
100	50	103	195	400	620	1150	1850	3250	6700
125	44	93	175	360	550	1020	1650	2950	6000
150	40	84	160	325	500	950	1500	2650	5500
175	37	77	145	300	460	850	1370	2450	5000
200	35	72	135	280	430	800	1280	2280	4600

LENGTH IN METERS	NORMAL IRON PIPE SIZES (INCHES) INPUT IN KW								
	1/2"	3/4"	1"	1 1/4"	1 1/2"	2"	2 1/2"	3"	4"
3.0	51	105	199	410	615	1160	1845	3221	6735
6.1	35	73	142	278	428	805	1277	2255	4626
9.1	28	59	110	225	346	644	1031	1830	3748
12.2	24	50	94	193	290	556	878	1552	3192
15.2	21	44	83	170	264	492	776	1391	2840
18.3	19	40	76	155	237	445	703	1259	2577
21.3	18	37	70	143	220	410	659	1142	2372
24.4	17	35	64	135	202	381	600	1083	2196
27.4	16	32	60	126	190	357	571	1010	2108
30.5	15	30	57	117	182	337	542	952	1962
38.1	13	27	51	105	161	299	483	864	1757
45.7	12	25	47	95	146	278	439	776	1610
53.3	11	23	42	88	135	249	401	717	1464
61.0	10	21	40	82	126	234	375	688	1347

⚠ WARNING

THE HEATER IS NOT INTENDED FOR OPERATION AT HIGHER THAN 10.5" (2.59 KPa) WATER COLUMN SUPPLY GAS PRESSURE. HIGHER GAS SUPPLY PRESSURES REQUIRE SUPPLEMENTAL REDUCING SERVICE REGULATION. EXPOSURE TO HIGHER GAS SUPPLY PRESSURE MAY CAUSE DAMAGE TO THE GAS CONTROLS WHICH COULD RESULT IN FIRE OR EXPLOSION. IF OVERPRESSURE HAS OCCURRED SUCH AS THROUGH IMPROPER TESTING OF GAS LINES OR EMERGENCY MALFUNCTION OF THE SUPPLY SYSTEM THE GAS VALVE MUST BE CHECKED FOR SAFE OPERATION. MAKE SURE THAT THE OUTSIDE VENTS ON THE SUPPLY REGULATORS AND THE SAFETY VENT VALVES ARE PROTECTED AGAINST BLOCKAGE. THESE ARE PARTS OF THE GAS SUPPLY SYSTEM, NOT THE HEATER. VENT BLOCKAGE MAY OCCUR DURING ICE STORMS.

IT IS IMPORTANT TO GUARD AGAINST GAS VALVE FOULING FROM CONTAMINANTS IN THE GAS WAYS. SUCH FOULING MAY CAUSE IMPROPER OPERATION, FIRE OR EXPLOSION.

IF COPPER SUPPLY LINES ARE USED THEY MUST BE INTERNALLY TINNED AND CERTIFIED FOR GAS SERVICE.

BEFORE ATTACHING THE GAS LINE BE SURE THAT ALL GAS PIPE IS CLEAN ON THE INSIDE.

TO TRAP ANY DIRT OR FOREIGN MATERIAL IN THE GAS SUPPLY LINE, A DIRT LEG (SOMETIMES CALLED A SEDIMENT TRAP OR DRIP LEG) MUST BE INCORPORATED IN THE PIPING (SEE FIGURE 13). THE DIRT LEG MUST BE READILY ACCESSIBLE AND NOT SUBJECT TO FREEZING CONDITIONS. INSTALL IN ACCORDANCE WITH RECOMMENDATIONS OF SERVING GAS SUPPLIERS. REFER TO THE NATIONAL FUEL GAS CODE.

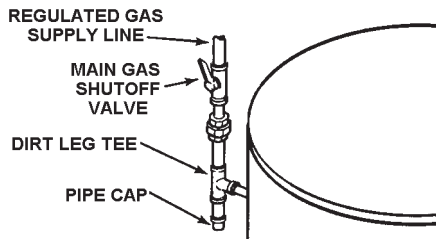

FIGURE 13.

CONNECTION OF GAS PIPE

1. When connecting gas pipe to unit, apply wrench to flange only. Note: Do not use wrench on gas valve or gas bracket. See Figure 14.
2. PERFORM THE GAS LEAK TEST ANY TIME WORK IS DONE ON A GAS SYSTEM TO AVOID THE POSSIBILITY OF FIRE OR EXPLOSION WITH PROPERTY DAMAGE, PERSONAL INJURY OR LOSS OF LIFE.

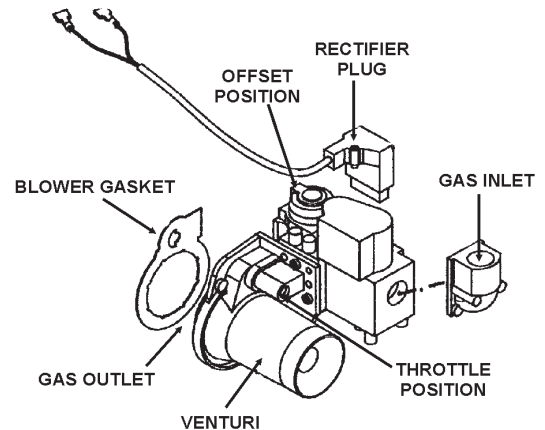

FIGURE 14.

The Gas Leak Test is performed as follows: Paint pipe connections upstream of gas control with a rich soap and water solution to test for leaks before operating main burner. Bubbles indicate gas leak. To stop leak, tighten pipe connections. After piping connections are checked, turn on main burner. With main burner in operation, paint pipe joints (including flanges), pilot gas tubing connections and control inlet and outlet with rich soap and water solution. Bubbles indicate gas leak. To stop leak, tighten flange screws, joints and pipe connections. Replace part if leak can't be stopped.

To prevent damage, care must be taken not to apply too much torque when attaching gas supply pipe to gas valve inlet.

Apply joint compounds (pipe dope) sparingly and only to the male threads of pipe joints. Do not apply compound to the first two threads. Use compounds resistant to the action of liquefied petroleum gases.

DISCONNECT THE APPLIANCE AND ITS MANUAL GAS SHUTOFF VALVE FROM THE GAS SUPPLY PIPING SYSTEM DURING ANY SUPPLY PRESSURE TESTING EXCEEDING 1/2 PSIG (3.45Kpa). GAS SUPPLY LINE MUST BE CAPPED WHEN DISCONNECTED FROM THE HEATER. FOR TEST PRESSURES OF 1/2 PSIG (3.45Kpa) OR LESS, THE APPLIANCE NEED NOT BE DISCONNECTED, BUT MUST BE ISOLATED FROM THE SUPPLY PRESSURE TEST BY CLOSING THE MANUAL GAS SHUTOFF VALVE.

BEFORE PLACING THE HEATER IN OPERATION, CHECK FOR GAS LEAKAGE. USE SOAP AND WATER SOLUTION OR OTHER MATERIAL ACCEPTABLE FOR THE PURPOSE OF LOCATING GAS LEAKS. DO NOT USE MATCHES, CANDLES, FLAME OR OTHER SOURCES OF IGNITION FOR THIS PURPOSE.

PURGING

Gas line purging is required with new piping or systems in which air has entered.

CAUTION

PURGING SHOULD BE PERFORMED BY PERSONS EXPERIENCED IN THIS TYPE OF GAS SERVICE. TO AVOID RISK OF FIRE OR EXPLOSION, PURGE DISCHARGE MUST NOT ENTER CONFINED AREAS OR SPACES WHERE IGNITION CAN OCCUR. THE AREA MUST BE WELL VENTILATED AND ALL SOURCES OF IGNITION MUST BE INACTIVATED OR REMOVED.

GAS METER SIZE - CITY GASES ONLY

Be sure that the gas meter has sufficient capacity to supply the full rated gas input of the water heater as well as the requirements of all other gas fired equipment supplied by the meter. If the gas meter is too small, ask the gas company to install a larger meter having adequate capacity.

GAS PRESSURE REGULATION

Main line gas pressure to the water heater should be between a maximum 10.5" (2.59Kpa) W.C. (14.0"/3.45Kpa for propane) and a minimum as shown in Table 4: that is, for Natural Gas, 4.8" (1.18Kpa) W.C. and 8.5" (2.08Kpa) for Propane Gas. The inlet gas pressure must not exceed the maximum value. A service regulator must be installed within 10' (305 cm) of unit.

WARNING

FAILURE TO INSTALL A PRESSURE REGULATOR WITHIN 10 FEET OF THE WATER HEATER CAN RESULT IN LEAKAGE OF FLUE GASES INTO THE SURROUNDING ROOM. SERIOUS PERSONAL INJURY OR DEATH COULD RESULT FROM INHALATION OF CARBON MONOXIDE GAS.

GAS VALVES

WARNING

SHOULD OVERHEATING OCCUR OR THE GAS SUPPLY FAIL TO SHUT OFF, TURN OFF THE MANUAL GAS CONTROL VALVE TO THE APPLIANCE.

SYSTEM CONNECTIONS

The system installation must conform to these instructions and to the local code authority having jurisdiction. Good practice requires that all heavy piping be supported.

THERMOMETERS (Not Supplied)

Thermometers should be obtained and field installed as shown in the installation diagrams.

Thermometers are installed in the system as a means of detecting the temperature of the outlet water supply.

RELIEF VALVE

This heater is equipped with an approved temperature and pressure relief valve. ASME ratings cover pressure relief. CSA ratings cover release rate with temperature actuation.

FOR SAFE OPERATION OF THE WATER HEATER, THE RELIEF VALVE(S) MUST NOT BE REMOVED OR PLUGGED.

In addition to the appliance relief valve, each remote storage tank which may be used in conjunction with this appliance should also be installed with a properly sized, rated and approved temperature (ANSI) and pressure (ASME) relief valve(s). This relief valve should comply with the standard for relief valves for hot water supply systems. ANSI Z21.22-CSA 4.4.

Your local code authority may have other specific relief valve requirements.

WARNING

THE PURPOSE OF A RELIEF VALVE IS TO AVOID EXCESSIVE PRESSURE OR TEMPERATURE INTO THE STEAM RANGE, WHICH MAY CAUSE SCALDING AT FIXTURES, TANK EXPLOSION, SYSTEM OR HEATER DAMAGE. NO VALVE IS TO BE PLACED BETWEEN THE RELIEF VALVE AND THE TANK.

A DRAIN LINE MUST BE CONNECTED TO THE RELIEF VALVE TO DIRECT DISCHARGE TO A SAFE LOCATION TO AVOID SCALDING OR WATER DAMAGE. THIS LINE MUST NOT BE REDUCED FROM THE SIZE OF THE VALVE OUTLET AND MUST NOT CONTAIN VALVES OR RESTRICTIONS, NOR SHOULD IT BE LOCATED IN FREEZING AREAS. DO NOT THREAD OR CAP THE END OF THIS LINE. RESTRICTED OR BLOCKED DISCHARGE WILL DEFEAT THE PURPOSE OF THE VALVE AND IS UNSAFE. THE DISCHARGE LINE SHOULD BE INSTALLED TO ALLOW COMPLETE DRAINAGE OF BOTH THE VALVE AND LINE.

WATER LINE CONNECTIONS

This manual provides detailed installation diagrams (see back section of this manual) for typical methods of application for the water heaters.

The water heater may be installed by itself, or with a separate storage tank.

CLOSED SYSTEM

CAUTION

A closed system will exist if a check valve (without bypass), pressure reducing valve (without bypass), or a water meter (without bypass) is installed in the cold water line between the water heater and street main (or well).

Excessive pressure may develop causing premature tank failure or intermittent relief valve operation. This type of failure is not covered by the limited warranty. An expansion tank or a similar device may be required in the inlet supply line between the appliance and the meter or valve to compensate for the thermal expansion of water under supply pressure.

If a water heater is installed in a closed water system, check local codes or contact the water supplier or local plumbing inspector on how to control this situation.

WATER (POTABLE) HEATING AND SPACE HEATING

1. All piping components connected to this unit for space heating applications should be suitable for use with potable water.
2. Toxic chemicals, such as those used for boiler treatment, should **NEVER** be introduced into this system.

- This unit may never be connected to any existing heating system or component(s) previously used with non-potable water heating appliance.
- When the system requires water for space heating at temperatures higher than required for domestic water purposes, a tempering valve must be installed. Please refer to the installation diagrams on pages 23 through 28 in the back of manual for suggested piping arrangements.

HEATER WIRING

IF ANY OF THE ORIGINAL WIRE AS SUPPLIED WITH THE APPLIANCE MUST BE REPLACED, IT MUST BE REPLACED WITH 105°C OR ITS EQUIVALENT, EXCEPT IN THE BURNER HOUSING. IN THIS CASE USE 200°C WIRE.

THE COMPUTER CONTROL REQUIRES A SOURCE OF STABLE CLEAN ELECTRICITY FOR PROPER OPERATION. INSTALLING THE HEATER ON A BRANCH CIRCUIT THAT HAS ELECTRONIC NOISE, IS SUBJECT TO FLUCTUATIONS IN VOLTAGE LEVEL OR HAS AN APPLIANCE WHICH GENERATES EMF OF RFI INTERFERENCE

CAN CAUSE THE CONTROLLER TO MALFUNCTION. A HIGH QUALITY POWER CONDITIONER MUST BE INSTALLED IF THE ABOVE CONDITIONS EXIST. MALFUNCTIONS CAUSED BY A POOR ELECTRICAL SUPPLY ARE NOT COVERED UNDER YOUR WARRANTY.

The controller is wired to the heater as shown in Figure 15. The model and rating plate provides the electrical information needed to size the complete heater branch supply.

All electrical work must be installed in accordance with the National Electrical Code, NFPA 70.

When installed, the appliance must be electrically grounded in accordance with local codes or, in the absence of local codes, with the National Electrical Code, ANSI/NFPA 70.

DO NOT ENERGIZE THE BRANCH CIRCUIT BEFORE THE HEATER TANK IS FILLED WITH WATER.

NOTE: This controller is Polarity Sensitive. If the Hot and Neutral Supply Voltage is reversed, the controller will not sense flame. Verify polarity before connecting the unit.

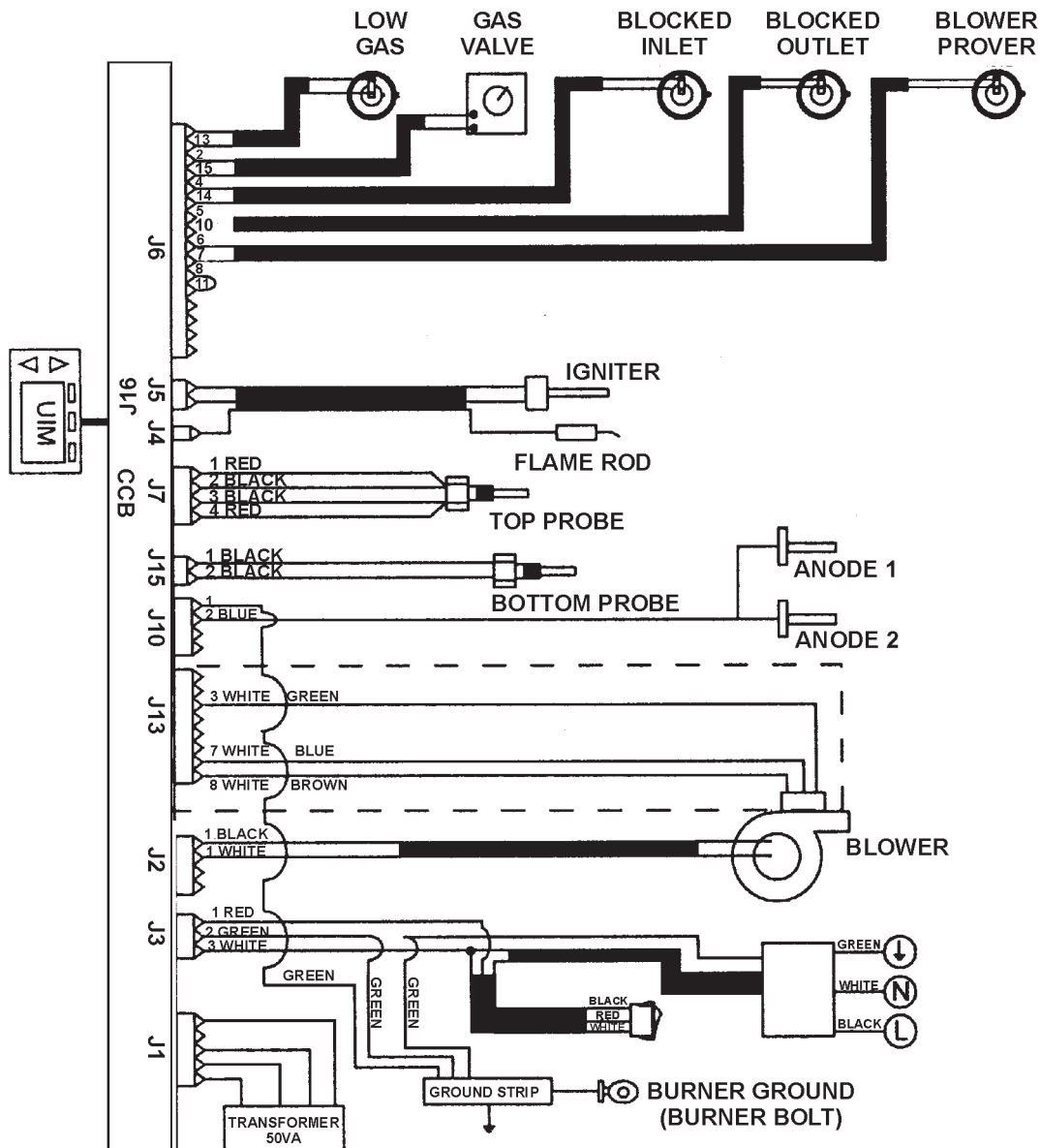

FIGURE 15.

USING THE ELECTRONIC CONTROLLER

1. Overview

Interaction with the water heater controller is done through an up, a down, and three operation buttons. These buttons are illustrated to the right. Operation of the three lower buttons is defined immediately above them on the screen. The [UP] and [DN] buttons are used to navigate through the menus and make adjustments to the water heater.

While the water heater is operating, the user interface will display the desktop screen (if there are no active fault or alert conditions). An example of this screen is shown to the right. The first temperature on this screen is the temperature of the water inside the tank. The second temperature on this screen is the Operating Set Point. The Operating Set Point is the temperature at which the water heater will maintain the water inside the tank. The third line on the screen is a text description of the Operational State of the water heater (please see Operating States for more details).

The following status icons describe graphically operational details of the heater. The legend of all the status icons is listed below.

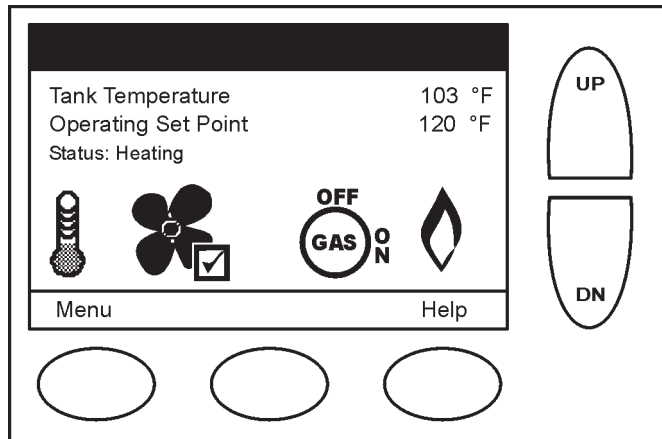

STAU ICON	DESCRIPTION
	The temperature of the water in the tank has fallen and the water heater will now initialize a new heating cycle.
	The temperature of the water in the tank has reached the <i>Operating Set Point</i> .
	The control is unable to initiate any further heating cycles. This is usually caused by a fault condition detected by the control, but can also occur when an external system (like an energy management system) has asked the water heater to discontinue any further heat cycles.
	The blower is being energized.
	The blower pressure switch has been made.

STAU ICON	DESCRIPTION
	The igniter has been energized
	The igniter has been energized and sufficient current for ignition has been detected.
	The control has requested that the gas valve be turned on.
	The control has sensed flame in the burner
	The control has detected a fault condition
	The control has detected an alert condition. These conditions will not cause the water heater to discontinue further heating cycles, but does merit attention.

2. Operating States

In the main desktop screen, there are some specific Operating States that are indicated on the status line. These are summarized below:

STATE	DESCRIPTION
Standby	The water heater is not in an active heating cycle. Usually this means the temperature in the tank has reached a sufficient temperature and has not dropped low enough to initiate a call for heat.
Input Verification	The electronic controls are waiting for specific conditions to occur (primarily pressure switch states) before the unit can continue to heat water.
Short Cycle Delay	The electronic controls are waiting a defined period of time before initiating another call for heat just after the last on has ended. This prevents the water heater from "Short Cycling."
Pre-Purge	The blower has been energized and excess gas in the heater exchanger is being flushed to start a new heating cycle.
Igniter Warmup	The igniter has been energized and is currently

STATE	DESCRIPTION
Ignition Activation	The controls are allowing for a steady flame to be established in the burner
Ignition Verification	Assurance of proper flame sense is being determined
Inter-Purge	After a failure to ignite the burner, the control is attempting to purge any excess gas from the heater exchanger before another attempt to light.
Heating	The water heater has been properly lit, and the water in the tank is being heated
Post-Purge	Excess gas is being pushed out of the heater exchanger after a successful heating cycle.
Fault	The water heater control has detected a fault. No further heating of the water will be done.





3. Adjusting the Operating Set Point

The *Operating Set Point* of this water heater determines the regulated temperature for the water in the tank. This parameter is adjusted in the Temperature menu. Items in this menu allow you to monitor different temperature readings in the tank along with adjusting the *Operating Set Point* and *Differential*.

ACTION:

From the desktop screen, press **Menu**.

DISPLAY:

Tank Temperature	103 °F
Operating Set Point	120 °F
Status: Heating	
	
	
Menu	Help

ACTION:

From the Main Menu, press **Select** to enter the "Temperatures" screen.

DISPLAY:

Main Menu	
Temperatures	▲
Heater Status	
Display Settings	
Heater Information	
Current Fault (none)	
Select	Back Help

ACTION:

Press **Change** then use the **UP** and **DOWN** buttons to change the Set Point.

Note: This procedure can also be used to change the *Differential*. The Tank, Upper and Lower Temperatures are not user changeable. They are determined by the temperature probes on the heater.

DISPLAY:

Temperatures	
Operating Set Point	120°F
Differential	5°F
Tank Temperature	127°F
Upper Temperature	130°F
Lower Temperature	113°F
(Heater Regulated to Tank)	
Change	Back Help

ACTION:

Press **Update** to accept the change or **Cancel** to reset it.

DISPLAY:

Temperatures	
Operating Set Point	120°F
Differential	5°F
Tank Temperature	127°F
Upper Temperature	130°F
Lower Temperature	113°F
(Heater Regulated to Tank)	
Update	Cancel

4. Changing the Display Units

The display interface to the heater has the option of selecting between degrees Fahrenheit and degrees Celsius for temperature displays. This can be found in the "Display Settings" menu. Also in this menu, you may adjust how the backlight operates and the contrast of the LCD screen.

ACTION:

From the Main Menu, press the **DOWN** button to highlight "Display Settings" then press **Select**.

DISPLAY:

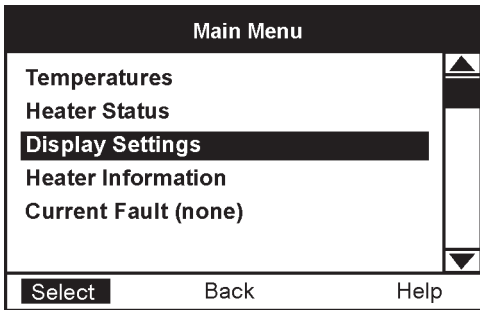

ACTION:

Use the **UP** and **DOWN** buttons to highlight the desired setting. Then press **Change**. Again, use the **UP** and **DOWN** buttons to scroll through the options for that setting.

DISPLAY:

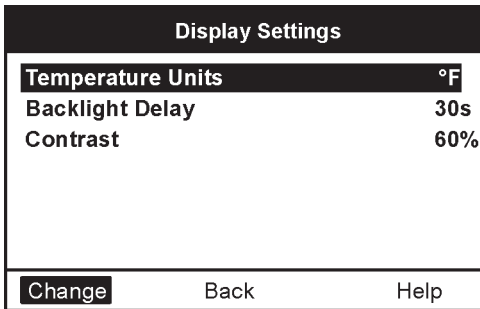

ACTION:

Press **Update** to accept the change or **Cancel** to reject it.

DISPLAY:

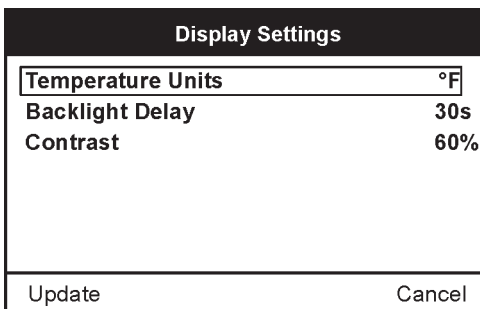

5. Fault and Alert Conditions

This water heater is equipped with electronic controls that have the ability to monitor almost all aspects of the water heater operation. In the case that there is an undesirable or unsafe condition that occurs, the water heater controls will detect this condition and determine the appropriate action. Part of this is displaying the information on the LCD in plain text that accurately describes the condition and diagnostics information that can be used to correct the issue.

There are two types of conditions that can occur during operation. These are Alerts and Faults:

• **Alerts:** This is a non-safety related condition that the control has detected that may cause the water heater to operate in a less than optimal condition, but does not pose a safety concern.

NOTE: When these conditions occur, continued heating cycles will continue and the heater will attempt to regulate the water in the tank to the *Operating Set Point*.

Example of an Alert:

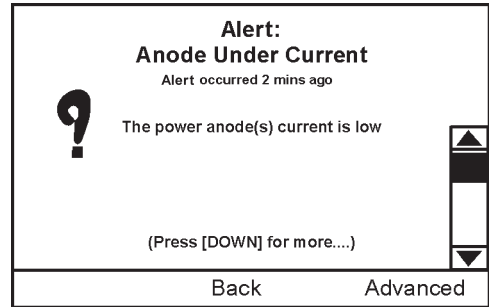

• **Faults:** This is a safety related condition that has been detected by the heater.

NOTE: When these conditions occur, the water heater will not continue any further heating cycles and the water will no longer be heated until the condition is corrected and, in most cases, power has been cycled.

Example of a Fault:

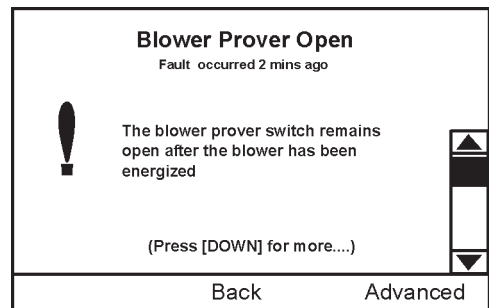

Advanced Diagnostics Information

When a fault or alert has been declared, advanced information can be found in the control. By pressing the Advanced button, detailed information can be found regarding diagnosing and resolving the problem.

WARNING: Usage of the Advanced information requires ability equivalent to that of a licensed tradesmen in the field involved.

6. Access to the Current Fault or Alert

When a fault or alert has been detected by the control, it will automatically be displayed on the screen and the back light will blink. If you choose to leave the current fault or alert by pressing the Back key, you can always return to the fault screen through the menu.

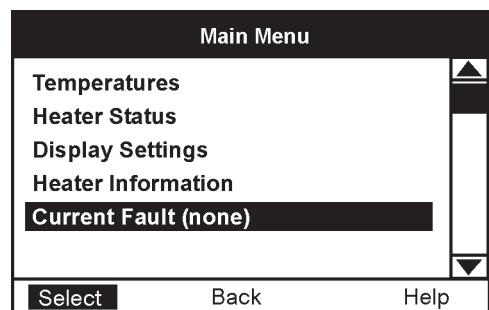

ACTION:

To get to the current fault information screen, press **Menu**.

DISPLAY:

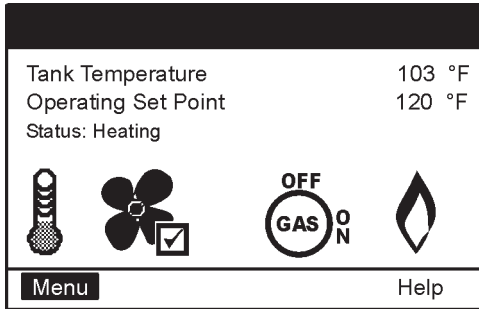

ACTION:

Press the **DOWN** button to highlight "current Fault" and press **Select**.

DISPLAY:

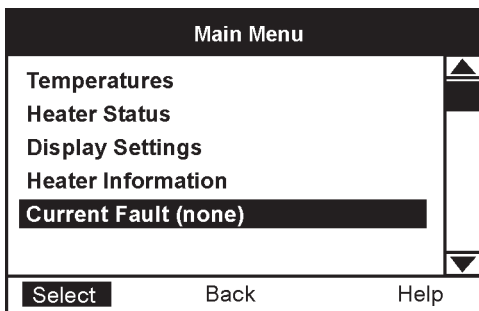

ACTION:

Press the **DOWN** button for more information.

DISPLAY:

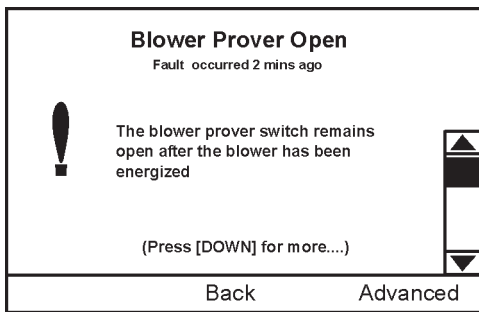

7. Viewing the Fault History

The controller for this water heater will store a history of ten of the last Fault and Alert conditions that occurred. This is stored in the Fault History. Along with all the information about the fault, including an estimate time of when the fault occurred, information regarding the advanced diagnostics for that fault can be accessed at any time.

ACTION:

Press the **DOWN** button for more information.

DISPLAY:

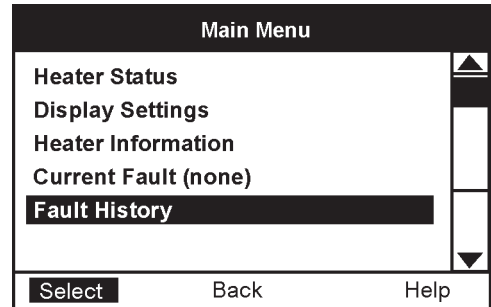

ACTION:

Press the **DOWN** key to scroll through the fault history. If you select a specific fault or Alert, you may press the **VIEW** button to view details regarding this fault.

DISPLAY:

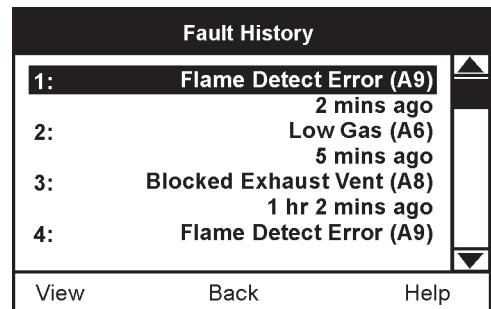

8. Viewing Information About the Heater

The electronic control for this water heater monitors many different aspects of the water to ensure safe and optimal operation. Much of the information monitored is available to view in two areas of the control. The first is the "Heater Status" and; the second is "Heater Information." These items can be selected through the main menu in the same fashion as described above. In these menus, detailed information about the water heater and the current status of specific conditions can be found.

PRIOR TO START UP REQUIRED ABILITY

INSTALLATION OR SERVICE OF THIS WATER HEATER REQUIRES ABILITY EQUIVALENT TO THAT OF A LICENSED TRADESMAN IN THE FIELD INVOLVED. PLUMBING, AIR SUPPLY, VENTING, GAS SUPPLY AND ELECTRICAL WORK ARE REQUIRED.

Before attempting start-up, thoroughly study and familiarize yourself with the exact sequence of operation and all other details on the specific heater being used.

The power burner is equipped with an ignition system which automatically sequences prepurge and ignition, senses and ignites main burner flame and sequences burner operation. Heater is equipped with an ignition control which locks out after three unsuccessful ignition attempts. Familiarize yourself with the sequence of operation of this unit prior to start-up.

Be certain that the water heater is full of water, that air is purged from all lines, there are no leaks (gas and water), and all inlet water lines are open.

The following test equipment should be on hand (all test equipment must be acclimated to ambient temperature before calibration and use.)

- Two U-tube manometers or calibrated pressure gages that can read 0-10" (0-2.5Kpa) and 0-35" (0-8.7Kpa) W.C. pressure gauges.
- Attach a gas pressure gauge or manometer to the upstream side of main gas cock and a gas pressure gauge or manometer to the manifold pressure tap (see Figure 15).
- You are now ready to begin the burner start-up procedure.

OPERATING INSTRUCTIONS

IMPORTANT

IT IS RECOMMENDED THAT A QUALIFIED SERVICE TECHNICIAN PERFORM THE INITIAL FIRING OF THE HEATER. AT THIS TIME THE USER SHOULD ASK THE TECHNICIAN ANY QUESTIONS IN REGARD TO THE OPERATION AND MAINTENANCE OF THE UNIT.



CAUTION

BEFORE PROCEEDING WITH THE OPERATION OF THE UNIT, MAKE SURE HEATER AND SYSTEM ARE FILLED WITH WATER AND ALL AIR IS EXPELLED FROM HEATER AND PIPING.

NEVER OPERATE THE HEATER WITHOUT FIRST BEING CERTAIN IT IS FILLED WITH WATER AND A TEMPERATURE AND A PRESSURE RELIEF VALVE IS INSTALLED IN THE RELIEF VALVE OPENING OF THE HEATER. DO NOT ATTEMPT TO OPERATE HEATER WITH COLD WATER INLET VALVE CLOSED.

FILLING:

1. Close the heater drain valve.
2. Open a nearby hot water faucet to permit the air in the system to escape.
3. Fully open the cold water inlet pipe valve allowing the heater and piping to be filled.
4. Close the hot water faucet as water starts to flow.
5. The heater is ready to be operated.

THE MAIN MANUAL GAS SHUTOFF VALVE MUST HAVE BEEN CLOSED FOR AT LEAST FIVE (5) MINUTES. THIS WAITING PERIOD IS AN IMPORTANT SAFETY STEP. ITS PURPOSE IS TO PERMIT GAS THAT MIGHT HAVE ACCUMULATED IN THE COMBUSTION CHAMBER TO CLEAR. IF YOU DETECT GAS AT THE END OF THIS PERIOD, DO NOT PROCEED WITH LIGHTING. RECOGNIZE THAT GAS ODOR, EVEN IF IT SEEMS WEAK, MAY INDICATE THE PRESENCE OF ACCUMULATED GAS SOMEPLACE IN THE AREA

WITH A RISK OF FIRE OR EXPLOSION. SEE THE FRONT PAGE FOR STEPS TO BE TAKEN.

DO NOT USE THIS HEATER IF ANY PART HAS BEEN UNDER WATER. IMMEDIATELY CALL A QUALIFIED SERVICE TECHNICIAN TO INSPECT THE HEATER AND TO REPLACE ANY PART OF THE CONTROL SYSTEM AND ANY GAS CONTROL WHICH HAS BEEN UNDER WATER.

LIGHT THE UNIT IN ACCORDANCE WITH THE OPERATING INSTRUCTIONS LABEL ATTACHED TO THE HEATER.

THESE INSTRUCTIONS ARE REPEATED IN THE LIGHTING AND OPERATING LABEL ILLUSTRATION ON PAGE 20 IN THIS MANUAL.

ADJUSTMENT PROCEDURE INITIAL START-UP

Main line gas pressure to the water heater for natural gas should be between a maximum of 10.5" (2.59Kpa for natural gas) W.C. (14.0"/3.45Kpa for propane) and a minimum as shown in Table 4: that is, for Natural Gas 4" (.98Kpa) W.C. and 9.0" (1.97Kpa) for Propane Gas. The inlet gas pressure must not exceed the maximum value. A service regulator must be installed within 10' (305 cm) of the unit.

The RUF 199 model incorporates a new gas control, which operates at 0"W.C. (0kPa) for both natural and propane gas. These models are configured prior to being shipped from the factory and no adjustments are necessary prior to startup. The controller monitors the air-flow and makes adjustments to the fan speed which in effect controls the amount of gas flow. Therefore, the unit will self-adjust to acquire the correct amount of input.

Once the unit is installed and filled with water and the inlet pressures confirmed, simply turn the switch "on" and observe operation. Cycle the unit "off" and "on" several times to ensure proper operation.

! WARNING

UNDER NO CIRCUMSTANCES SHOULD THE INPUT EXCEED THE RATE SHOWN ON THE HEATER RATING PLATE. OVER FIRING COULD RESULT IN DAMAGE OR SOOTING OF THE HEATER.

CATHODIC PROTECTION

! CAUTION

HYDROGEN GAS CAN BE PRODUCED IN A HOT WATER SYSTEM SERVED BY THIS HEATER THAT HAS NOT BEEN USED FOR A LONG PERIOD OF TIME (GENERALLY TWO WEEKS OR MORE). HYDROGEN GAS IS EXTREMELY FLAMMABLE. To reduce the risk of injury under these conditions, it is recommended that a hot water faucet be opened for several minutes before using any electrical appliance connected to the hot water system. If hydrogen is present, there will probably be an unusual sound such as air escaping through the pipe as the water begins to flow. There should be no smoking or open flame near the faucet at the time it is open.

PRECAUTIONS

IF THE UNIT IS EXPOSED TO THE FOLLOWING, DO NOT OPERATE HEATER UNTIL ALL CORRECTIVE STEPS HAVE BEEN MADE BY A QUALIFIED SERVICEMAN.

1. FLOODING TO OR ABOVE THE LEVEL OF THE BURNER OR CONTROLS
2. EXTERNAL FIRING
3. DAMAGE
4. FIRING WITHOUT WATER
5. SOOTING

NEVER OPERATE THE HEATER WITHOUT FIRST BEING CERTAIN IT IS FILLED WITH WATER AND A TEMPERATURE AND PRESSURE RELIEF VALVE IS INSTALLED IN THE RELIEF VALVE OPENING OF THE HEATER.

SHOULD OVERHEATING OCCUR OR THE GAS SUPPLY FAIL TO SHUT OFF, TURN OFF THE MANUAL GAS CONTROL VALVE TO THE APPLIANCE.

GENERAL INFORMATION

POWER BURNER

The initial start-up procedure of the unit is provided on page 20.

TABLE 4

GAS SUPPLY SPECIFICATIONS	Natural Gas 199	Propane Gas 199
Maximum Gas Supply Pressure	10.5" WC (2.59kpa)	14.0" WC (3.45kpa)
Nominal Gas Supply Pressure	7.0" WC (1.74Kpa)	11.0" WC (2.74Kpa)
Minimum Gas Supply Pressure	4.8" WC (1.18Kpa)	8.5" WC (2.08 Kpa)
Manifold Pressure	0" WC (OKpa)	0" WC (OKpa)

HIGH ALTITUDE INSTALLATIONS

! WARNING

THESE HEATERS ARE CERTIFIED FOR USE WITHOUT MODIFICATION FOR ALTITUDES UP TO 10,100 ft. (3078 m). INSTALLATIONS ABOVE

THESE ALTITUDES MAY REQUIRE REPLACEMENT OF THE BURNER ORIFICE. CALL THE TECHNICAL CENTER @ (800) 527-1953 FOR REQUIREMENTS.

Some gas utility companies derate their gas for altitude, making it unnecessary to install high altitude orifices. Call the local gas or utility company to verify BTU content.

Due to the input rating reduction at high altitudes, the output rating of the appliance is also reduced and should be compensated for in the sizing of the equipment for applications.

MAINTENANCE

GENERAL

KEEP APPLIANCE AREA CLEAR AND FREE FROM COMBUSTIBLE MATERIALS, GASOLINE AND OTHER FLAMMABLE VAPORS AND LIQUIDS. (SEE WARNING ON PAGE 5, LOCATING THE HEATER).

Water heater maintenance includes periodic tank flushing and cleaning, and removal of lime scale. The unit should be inspected and adjusted to maintain proper combustion. Refer to the following table. A periodic inspection of the venting system should be made. Where used, the water circulating pump should be oiled.

MAINTENANCE SCHEDULE

Following are the instructions for performing some of the recommended maintenance. Unit inspection and adjustment should be performed by a competent technician.

COMPONENT	OPERATION	INTERVAL	REQUIRED
Tank	Sediment Removal	Monthly	Flushing
Tank	Lime Scale Removal	Semi Annually	UN-LIME® Delimer
Relief Valve	Inspect	Semi Annually	
Blower	Clean Inlet Screen and Blower Wheel	As Required	Soft Brush
Vent System	Inspect	Every 3 Months	Joints should be sealed

FOR YOUR SAFETY READ BEFORE OPERATING



WARNING: If you do not follow these instructions exactly, a fire or explosion may result causing property damage, personal injury or loss of life.



BEFORE OPERATING: ENTIRE SYSTEM MUST BE FILLED WITH WATER AND AIR PURGED FROM ALL LINES.

- A. This appliance does not have a pilot. It is equipped with an ignition device which automatically lights the burner. **Do not try to light the burner by hand.**
- B. BEFORE OPERATING smell all around the appliance area for gas. Be sure to smell next to the floor because some gas is heavier than air and will settle on the floor.
- WHAT TO DO IF YOU SMELL GAS**
- Do not try to light any appliance.
 - Do not touch any electric switch; do not use any phone in your building.
 - Immediately call your gas supplier from a neighbor's phone. Follow the gas supplier's instructions.
- If you cannot reach your gas supplier, call the fire department.
- C. Use only your hand to push in the control buttons. Never use tools. If the control buttons will not push in, don't try to repair them, call a qualified service technician. Force or attempted repair may result in a fire or explosion.
- D. Do not use this appliance if any part has been under water. Immediately contact a qualified installer or service agency to replace a flooded water heater. Do not attempt to repair the unit. It must be replaced!

OPERATING INSTRUCTIONS

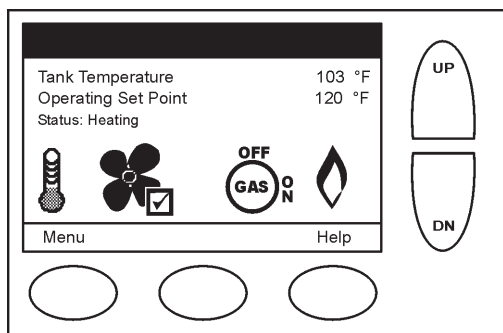

ON/OFF SWITCH

1. STOP! Read the safety information above on this label.
 2. Set the ON/OFF switch on the control panel to the "ON" position.
 3. Set the thermostat to the lowest setting.
 4. Set the ON/OFF switch on the control box to the "OFF" position.
5. This appliance is equipped with a device which automatically lights the burner. **DO NOT TRY TO LIGHT THE BURNER BY HAND.**
 6. Wait five (5) minutes to clear out any gas. If you then smell gas, STOP! Follow "B" in the safety information above on this label. If you don't smell gas, go to the next step.
 7. Turn on all electrical power to the appliance.
 8. Set the ON/OFF switch on the control box to the "ON" position.
 9. Set the thermostat to the desired setting.
CAUTION: Hotter water increases the risk of scald injury. Consult the instruction manual before changing temperature.
 10. If the appliance will not operate, follow the instructions "TO TURN OFF GAS TO APPLIANCE" and call your technician or gas supplier.

WARNING: TURN OFF ALL ELECTRIC POWER BEFORE SERVICING.

TURN OFF GAS TO APPLIANCE

1. Set the thermostat to the lowest setting.
2. Set the ON/OFF switch on the control panel to the "OFF" position.
3. Turn off all electrical power to the appliance if service is to be performed.

197781-000 REV. XX

199 MODELS.

FLUSHING

1. Turn off the heater electrical disconnect switch.
2. Open the drain valve and allow water to flow until it runs clean.
3. Close the drain valve when finished flushing.
4. Turn on the heater electrical disconnect switch.

DRAINING

The heater must be drained if it is to be shut down and exposed to freezing temperatures. Maintenance and service procedures may also require draining the heater.

1. Turn off the heater electrical disconnect switch.
 2. Close the cold water inlet valve to heater.
 3. Open a nearby hot water faucet to vent the system.
 4. Open the heater drain valve.
 5. If the heater is being drained for an extended shutdown, it is suggested the drain valve be left open during this period.
- Follow FILLING instructions when restoring hot water service.

SEDIMENT REMOVAL

Waterborne impurities consist of the particles of soil and sand which settle out and form a layer of sediment on the bottom of the tank.

For convenience, sediment removal and lime scale removal should be performed at the same time.

LIME SCALE REMOVAL

The amount of calcium carbonate (lime) released from water is in direct proportion to water temperature and usage. The higher the water temperature or water usage, the more lime deposits are dropped out of the water. This is the lime scale which forms in pipes, heaters and on cooking utensils.

Lime accumulation not only reduces the life of the equipment but also reduces efficiency of the heater and increases fuel consumption.

The usage of water softening equipment greatly reduces the hardness of the water. However, this equipment does not always remove all of the hardness (lime). For this reason it is recommended that a regular schedule for deliming be maintained.

The depth of lime buildup should be measured periodically. Heaters will have about 3" (7.6cm) of lime buildup when the level of lime has reached the bottom of the cleanout opening or about 1" (2.5cm) of lime buildup if it has reached the drain valve opening. A schedule for deliming should be set up, based on the amount of time it would take for a 1" (2.5cm) buildup of lime.

Example 1:

Initial inspection shows 1/2" (1.3cm) of lime accumulation. Therefore, the heater can be delimed once a year.

Example 2 :

Initial inspection shows 2" (5cm) of lime accumulation. Therefore, the heater should be delimed every 3 months.

Sediment and lime scale removal may be accomplished through the cleanout opening furnished on the heater, see Figure 25. The heater must be drained, see DRAINING, before removing cleanout cover on tank.

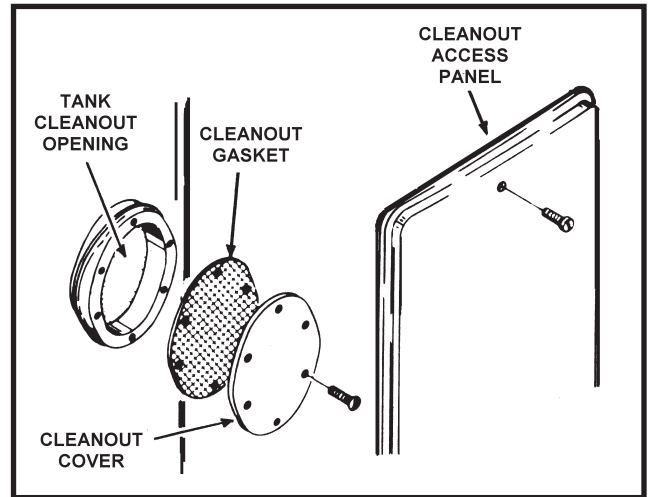

FIGURE 16.

To dissolve and remove the more stubborn mineral deposits, UN•LIME® Professional Delimer should be used.

The cleanout opening is shown in Figure 16. To clean heater through cleanout opening, proceed as follow:

1. Turn off water inlet valve, the heater electrical disconnect switch and open drain valve.
2. Remove outer cover plate from lower side of heater jacket.
3. Remove cover from cleanout opening.
4. Remove lime, scale or sediment using care not to damage the glass-lining.
5. Inspect cleanout plate gasket: If new gasket is required, replace with part number indicated in the Replacement Parts List.
6. Install cleanout plate. Be sure to draw plate up tight by tightening screws securely.
7. Close drain valve, open water inlet line and turn on the power burner electrical disconnect switch.
8. Check for water leakage.
9. Replace outer jacket cover plate.

POWERED ANODE SYSTEM

The RUF heaters are factory equipped with a powered anode system. The anodes are of a permanent design and do not need replacing unless damaged.

DRAIN VALVE AND ACCESS PANELS

The heaters are equipped with a 3/4" drain valve.

An access panel covers the cleanout opening in the tank which is sealed by a gasket and cover, figure 25.

RELIEF VALVE

At least twice a year, the temperature and pressure relief valve should be checked to ensure that it is in operating condition. To check the relief valve, lift the lever at the end of the valve several times. The valve should seat properly and operate freely.

If water does not flow, remove and inspect for obstructions or corrosion. Replace with a new valve of the recommended size as necessary. Inspection of the valve should be performed at least every three years. Do not attempt to repair the valve, as this could result in improper operation and a tank explosion. In areas with poor water conditions, it may be necessary to inspect the T&P valve more often than every three years.



CAUTION

BEFORE MANUALLY OPERATING THE VALVE, MAKE SURE THAT A DRAIN LINE HAS BEEN ATTACHED TO THE VALVE TO DIRECT THE DISCHARGE TO AN OPEN DRAIN. FAILURE TO TAKE THIS PRECAUTION COULD MEAN CONTACT WITH EXTREMELY HOT WATER PASSING OUT THE VALVE DURING THIS CHECKING OPERATION.

If the temperature and pressure relief valve on the heater discharges periodically or continuously, it may be due to thermal expansion of water in a closed water supply system, or, it may be due to a faulty relief valve.

Thermal expansion is the normal response of water when it is heated. In a closed system, thermal expansion will cause the system pressure

to build until the relief valve actuation pressure is equaled. Then, the relief valve will open, allowing some water to escape, slightly lowering the pressure.

Contact your water supplier or local plumbing inspector on how to control this situation.

Two common corrections are listed in the Checklist and Service Information which appears later in this manual.

ABOVE ALL, DO NOT PLUG THE TEMPERATURE AND PRESSURE RELIEF VALVE. THIS IS NOT A SOLUTION AND CAN CREATE A HAZARDOUS SITUATION.

CIRCULATING PUMP

The water heating system may include a circulating pump. Where used, it should be lubricated as directed by the circulator manufacturer.

VENT SYSTEM

Examine the vent system every 3 months. Points of inspection are as follows:

1. Check for obstructions and/or deterioration of vent piping and vent hood. Replace immediately where needed.
2. Vent pipe and vent hood screen should be cleaned of foreign material and soot. The screen is located inside the vent hood outlet and is accessible from the outside of the hood. Do not reach inside the vent hood when the heater is in operation.
3. Check all vent system connections for leakage and reseal as required using Hi Temp Silicone sealer or equivalent.

INSTALLATION DIAGRAMS

ONE TEMPERATURE - ONE HEATER VERTICAL STORAGE TANK FORCED CIRCULATION WITH OR WITHOUT BUILDING RECIRCULATION

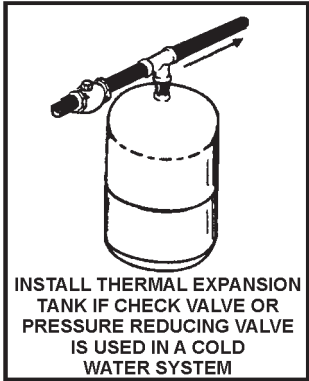

CAUTION: IF THE PLUMBING REQUIRES THE USE OF PIPES WITH DISSIMILAR MATERIAL (FOR EXAMPLE, STEEL AND COPPER), USE DIELECTRIC UNIONS TO PREVENT AN ELECTRO-GALVANIC ACTION BETWEEN THE PIPING COMPONENTS WITH DISSIMILAR MATERIALS.

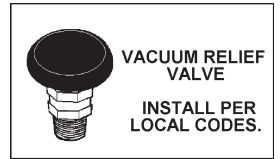
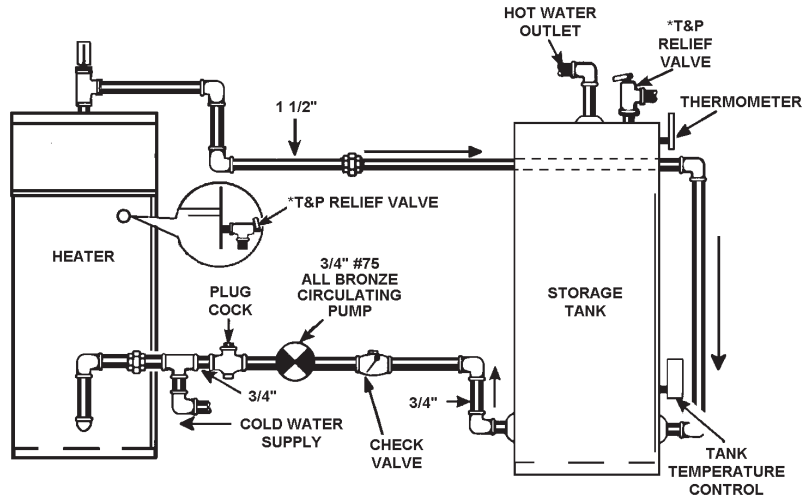

CAUTION: IF BUILDING COLD WATER SUPPLY HAS A BACK-FLOW PREVENTER, CHECK VALVE OR WATER METER WITH CHECK VALVE PROVISIONS FOR THERMAL EXPANSION OF WATER IN THE HOT WATER SYSTEM MUST BE PROVIDED

NOTE: CONNECT RETURN LINE FROM HOT WATER CIRCULATING LOOP (IF USED) TO COLD WATER INLET LINE.

* PIPE TO OPEN DRAIN

INSTALL IN ACCORDANCE WITH LOCAL CODES

ONE TEMPERATURE - ONE HEATER HORIZONTAL STORAGE TANK FORCED CIRCULATION WITH OR WITHOUT BUILDING RECIRCULATION



TEMPERATURE SETTING SHOULD NOT EXCEED SAFE TEMPERATURE AT FIXTURES. SEE WATER TEMPERATURE CONTROL WARNING ON PAGE 4. IF HIGHER PREHEAT TEMPERATURES ARE NECESSARY TO OBTAIN ADEQUATE BOOSTER OUTPUT, ADD AN ANTI-SCALD VALVE FOR HOT WATER SUPPLIED TO FIXTURES.

*PIPE TO OPEN DRAIN

INSTALL IN ACCORDANCE WITH LOCAL CODES

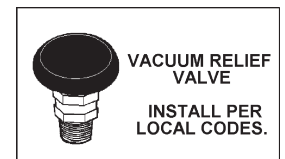
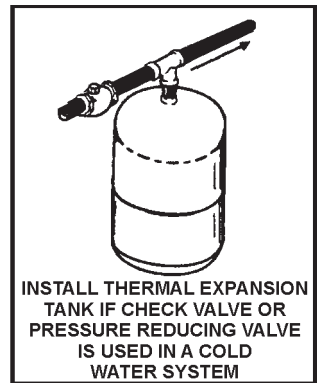
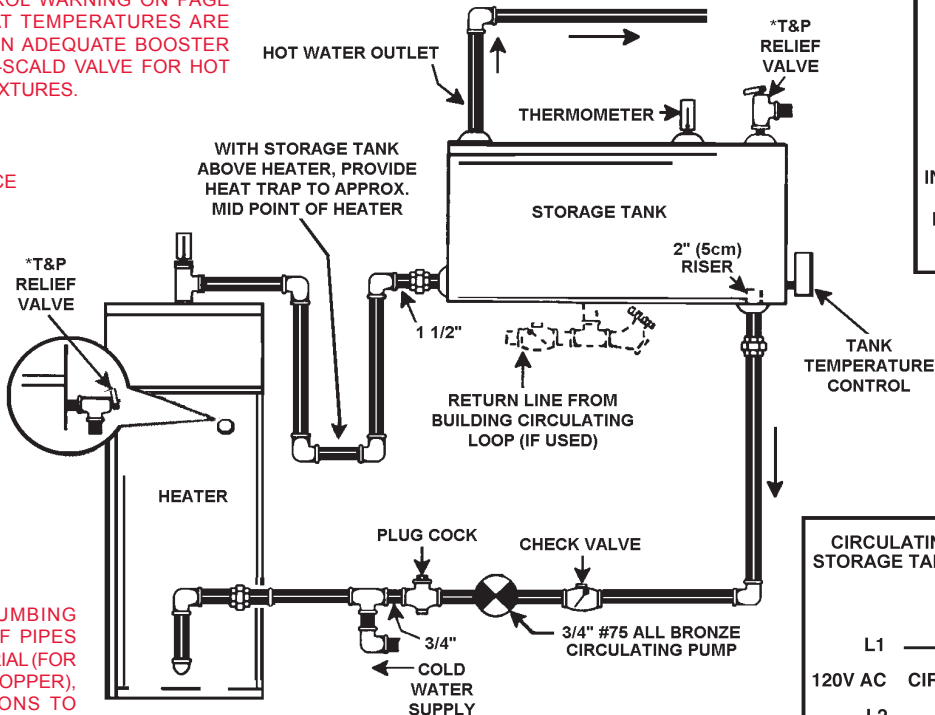

CAUTION: IF THE PLUMBING REQUIRES THE USE OF PIPES WITH DISSIMILAR MATERIAL (FOR EXAMPLE, STEEL AND COPPER), USE DIELECTRIC UNIONS TO PREVENT AN ELECTRO-GALVANIC ACTION BETWEEN THE PIPING COMPONENTS WITH DISSIMILAR MATERIALS.

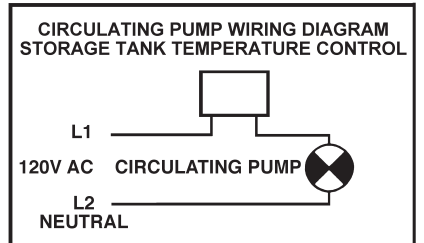

WIRING DIAGRAM FOR BOILER TO TANK LOOP AND/OR HOT WATER LOOP (IF USED).

TWO TEMPERATURE - ONE HEATER HIGH TEMPERATURE WITH OR WITHOUT BUILDING RECIRCULATION

! DANGER

TEMPERATURE SETTING SHOULD NOT EXCEED SAFE TEMPERATURE AT FIXTURES. SEE WATER TEMPERATURE CONTROL WARNING ON PAGE 4. IF HIGHER PREHEAT TEMPERATURES ARE NECESSARY TO OBTAIN ADEQUATE BOOSTER OUTPUT, ADD AN ANTI-SCALD VALVE FOR HOT WATER SUPPLIED TO FIXTURES.

CAUTION: IF BUILDING COLD WATER SUPPLY HAS A BACK-FLOW PREVENTER, CHECK VALVE OR WATER METER WITH CHECK VALVE PROVISIONS FOR THERMAL EXPANSION OF WATER IN THE HOT WATER SYSTEM MUST BE PROVIDED.

*PIPE RELIEF VALVE TO OPEN DRAIN.

NOTE: IF TEMPERED WATER IS RECIRCULATED, RETURN LINE SHOULD BE CONNECTED AT POINT "A".

INSTALL IN ACCORDANCE WITH LOCAL CODES.

CAUTION: IF THE PLUMBING REQUIRES THE USE OF PIPES WITH DISSIMILAR MATERIAL (FOR EXAMPLE, STEEL AND COPPER), USE DIELECTRIC UNIONS TO PREVENT AN ELECTRO-GALVANIC ACTION BETWEEN THE PIPING COMPONENTS WITH DISSIMILAR MATERIALS.

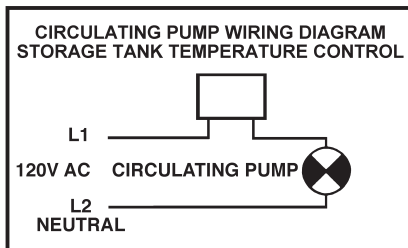
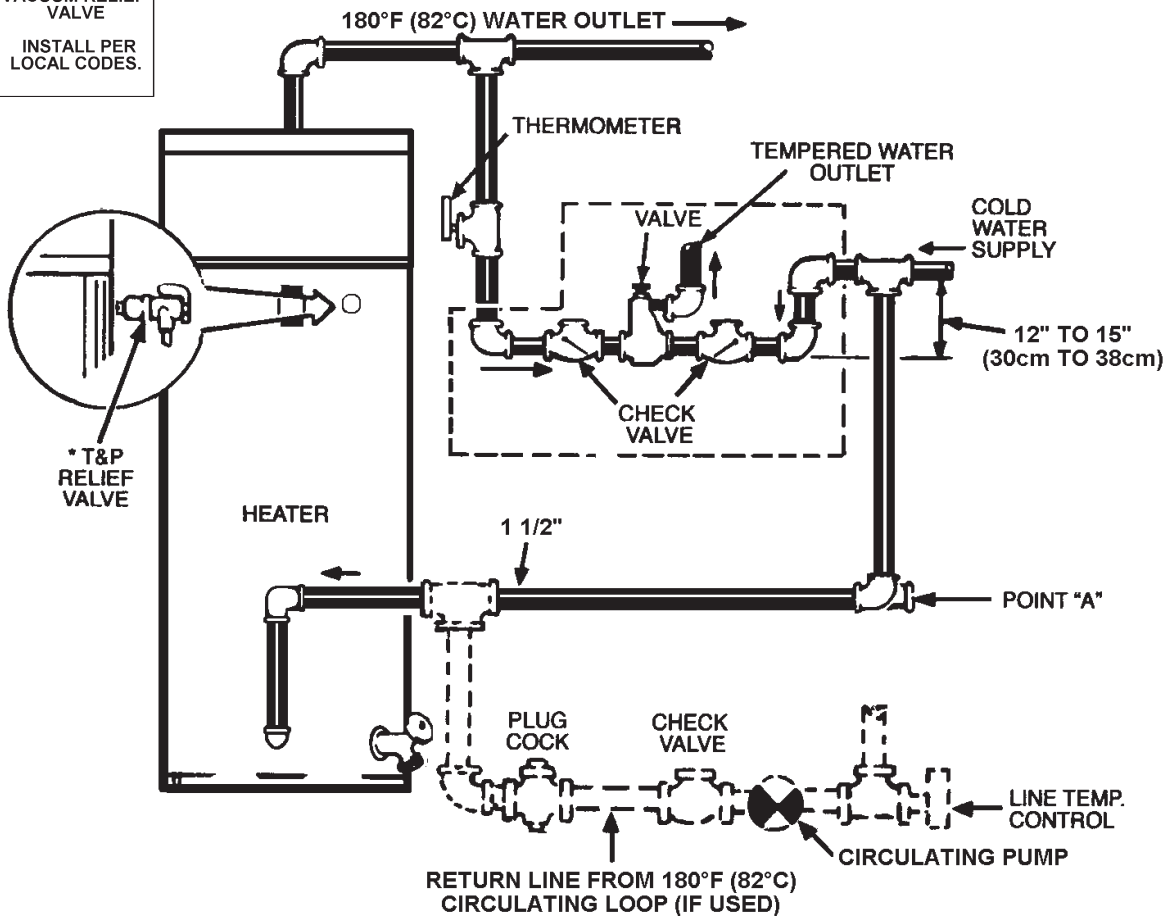
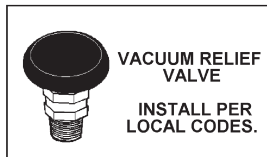
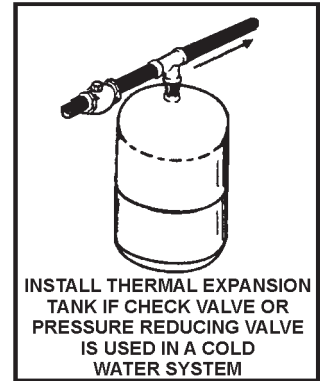

WIRING DIAGRAM FOR BOILER TO TANK LOOP AND/OR HOT WATER LOOP (IF USED).

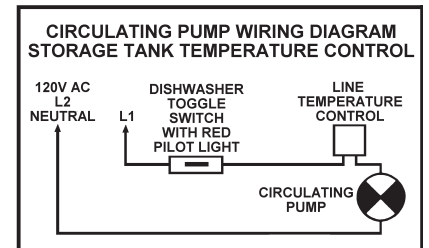

WIRING DIAGRAM FOR 180°F (82°C) LOOP (IF USED).

TWO TEMPERATURE - TWO HEATERS HIGH TEMPERATURE WITH OR WITHOUT BUILDING RECIRCULATION

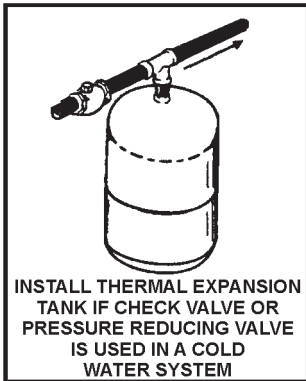

CAUTION: IF THE PLUMBING REQUIRES THE USE OF PIPES WITH DISSIMILAR MATERIAL (FOR EXAMPLE, STEEL AND COPPER), USE DIELECTRIC UNIONS TO PREVENT AN ELECTRO-GALVANIC ACTION BETWEEN THE PIPING COMPONENTS WITH DISSIMILAR MATERIALS.

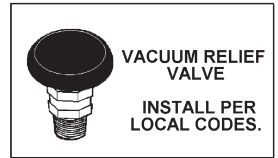
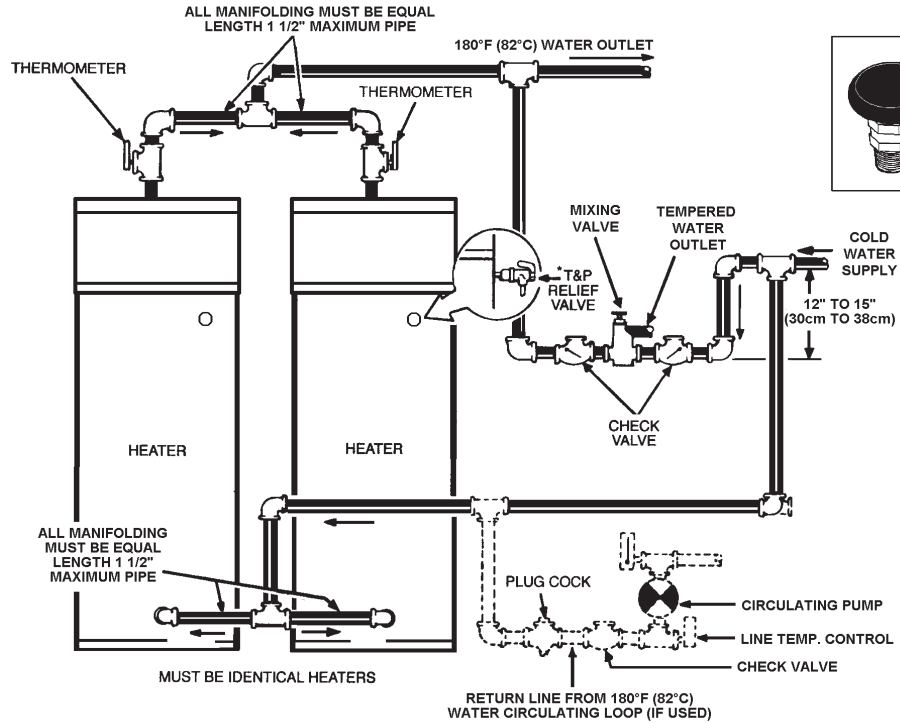

TWO TEMPERATURE - THREE HEATERS (TWO PRE-HEATERS/ONE BOOSTER HEATER) WITH OR WITHOUT BUILDING RECIRCULATION

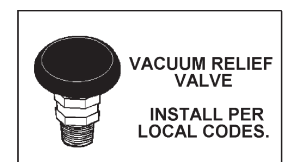
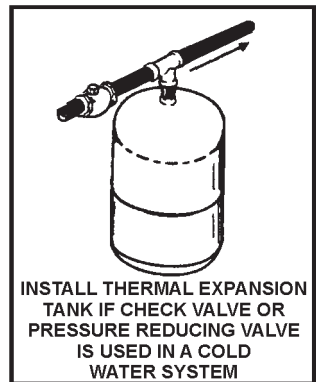
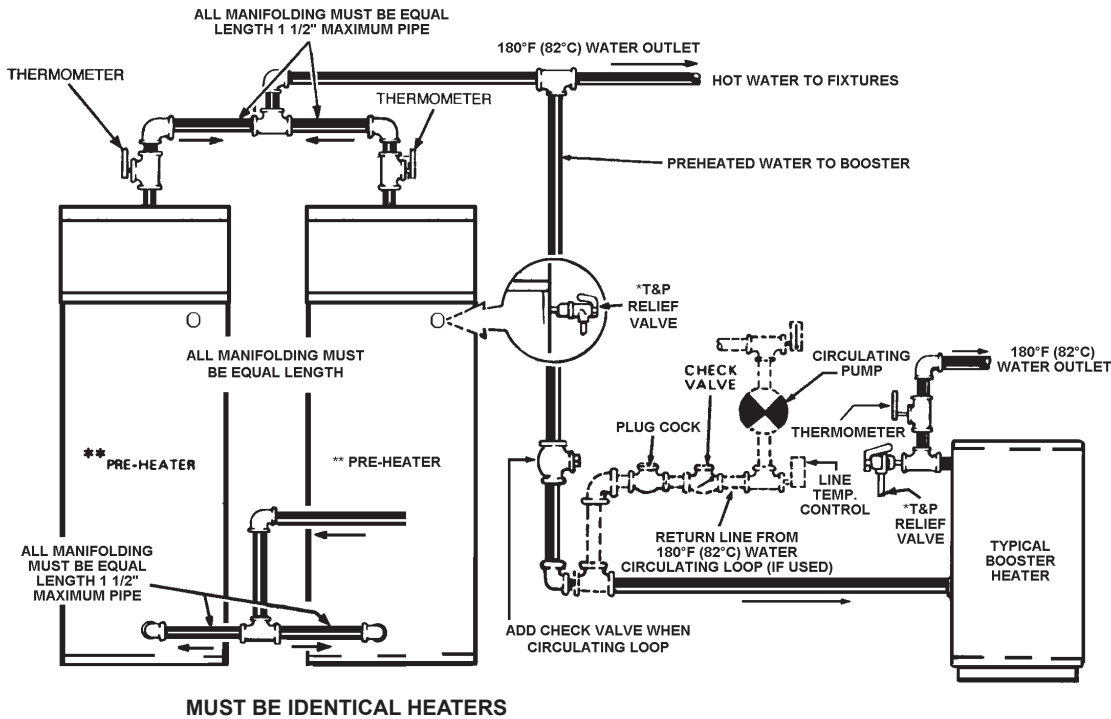

CAUTION: IF THE PLUMBING REQUIRES THE USE OF PIPES WITH DISSIMILAR MATERIAL (FOR EXAMPLE, STEEL AND COPPER), USE DIELECTRIC UNIONS TO PREVENT AN ELECTRO-GALVANIC ACTION BETWEEN THE PIPING COMPONENTS WITH DISSIMILAR MATERIALS.

FOR MULTIPLE HEATER INSTALLATION SEE MANIFOLD KIT SPECIFICATIONS, PAGE 30.

CAUTION: IF BUILDING COLD WATER SUPPLY HAS A BACK-FLOW PREVENTER, CHECK VALVE OR WATER METER WITH CHECK VALVE PROVISIONS FOR THERMAL EXPANSION OF WATER IN THE HOT WATER SYSTEM MUST BE PROVIDED.



TEMPERATURE SETTING SHOULD NOT EXCEED SAFE TEMPERATURE AT FIXTURES. SEE WATER TEMPERATURE CONTROL WARNING ON PAGE 4. IF HIGHER PREHEAT TEMPERATURES ARE NECESSARY TO OBTAIN ADEQUATE BOOSTER OUTPUT, ADD AN ANTI-SCALD VALVE FOR HOT WATER SUPPLIED TO FIXTURES.

TWO TEMPERATURE - TWO HEATERS (ONE PRE-HEATER/ONE BOOSTER HEATER) WITH OR WITHOUT BUILDING RECIRCULATION



TEMPERATURE SETTING SHOULD NOT EXCEED SAFE TEMPERATURE AT FIXTURES. SEE WATER TEMPERATURE CONTROL WARNING ON PAGE 4. IF HIGHER PREHEAT TEMPERATURES ARE NECESSARY TO OBTAIN ADEQUATE BOOSTER OUTPUT, ADD AN ANTI-SCALD VALVE FOR HOT WATER SUPPLIED TO FIXTURES.

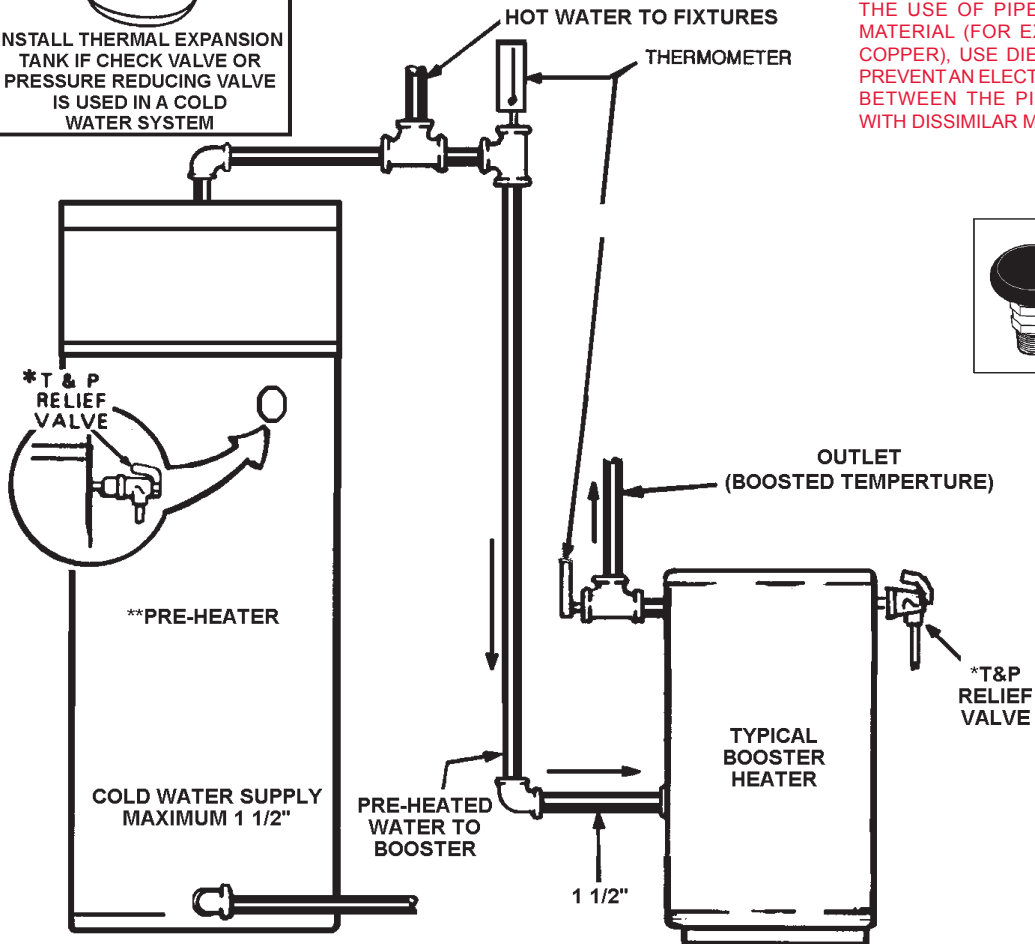
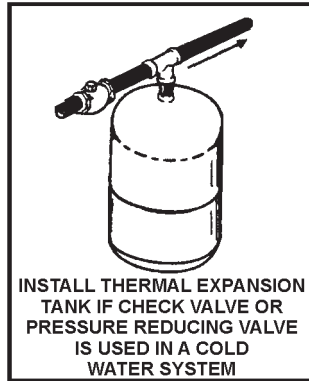

* PIPE RELIEF VALVE TO OPEN DRAIN

** 140°F (60°C) TO 150°F (66°C) SHOULD BE MAXIMUM WATER TEMPERATURE MAINTAINED IN THE PRE-HEATERS.

120°F (49°C) SHOULD BE THE MINIMUM TEMPERATURE OF WATER IN THE PRE- HEATERS.

CONNECT CIRCULATING LINE FROM FIXTURES, IF USED, TO COLD WATER SUPPLY LINE OF PRE-HEATER.

CONNECT CIRCULATING LINE OF 180°F (82°C) OR BOOSTED WATER, IF USED, TO INLET WATER LINE TO BOOSTER.

INSTALL IN ACCORDANCE WITH LOCAL CODES.

CAUTION: IF THE PLUMBING REQUIRES THE USE OF PIPES WITH DISSIMILAR MATERIAL (FOR EXAMPLE, STEEL AND COPPER), USE DIELECTRIC UNIONS TO PREVENT AN ELECTRO-GALVANIC ACTION BETWEEN THE PIPING COMPONENTS WITH DISSIMILAR MATERIALS.

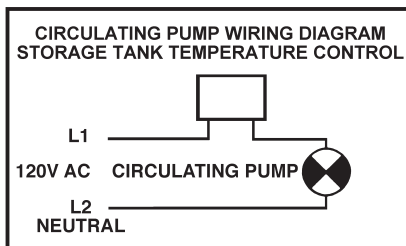
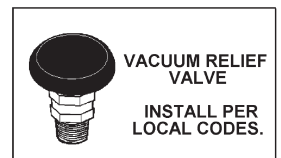

WIRING DIAGRAM FOR BOILER TO TANK LOOP AND/OR HOT WATER LOOP (IF USED).

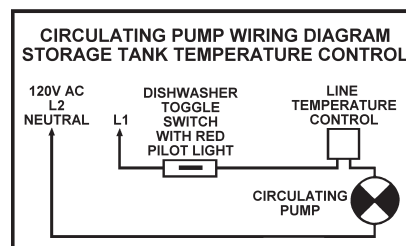

WIRING DIAGRAM FOR 180°F (82°C) LOOP (IF USED).

TWO TEMPERATURE - ONE HEATER HIGH TEMPERATURE WITH RECIRCULATION OF SANITIZING LOOP

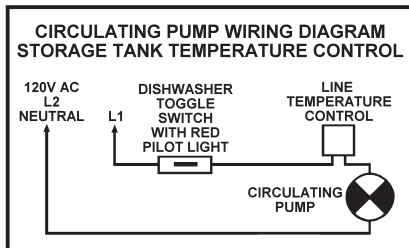

WIRING DIAGRAM FOR
180°F (82°C) LOOP (IF USED).

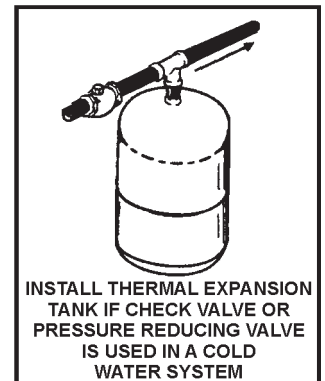
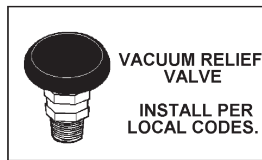

CAUTION: IF THE PLUMBING REQUIRES THE USE OF PIPES WITH DISSIMILAR MATERIAL (FOR EXAMPLE, STEEL AND COPPER), USE DIELECTRIC UNIONS TO PREVENT AN ELECTRO-GALVANIC ACTION BETWEEN THE PIPING COMPONENTS WITH DISSIMILAR MATERIALS.

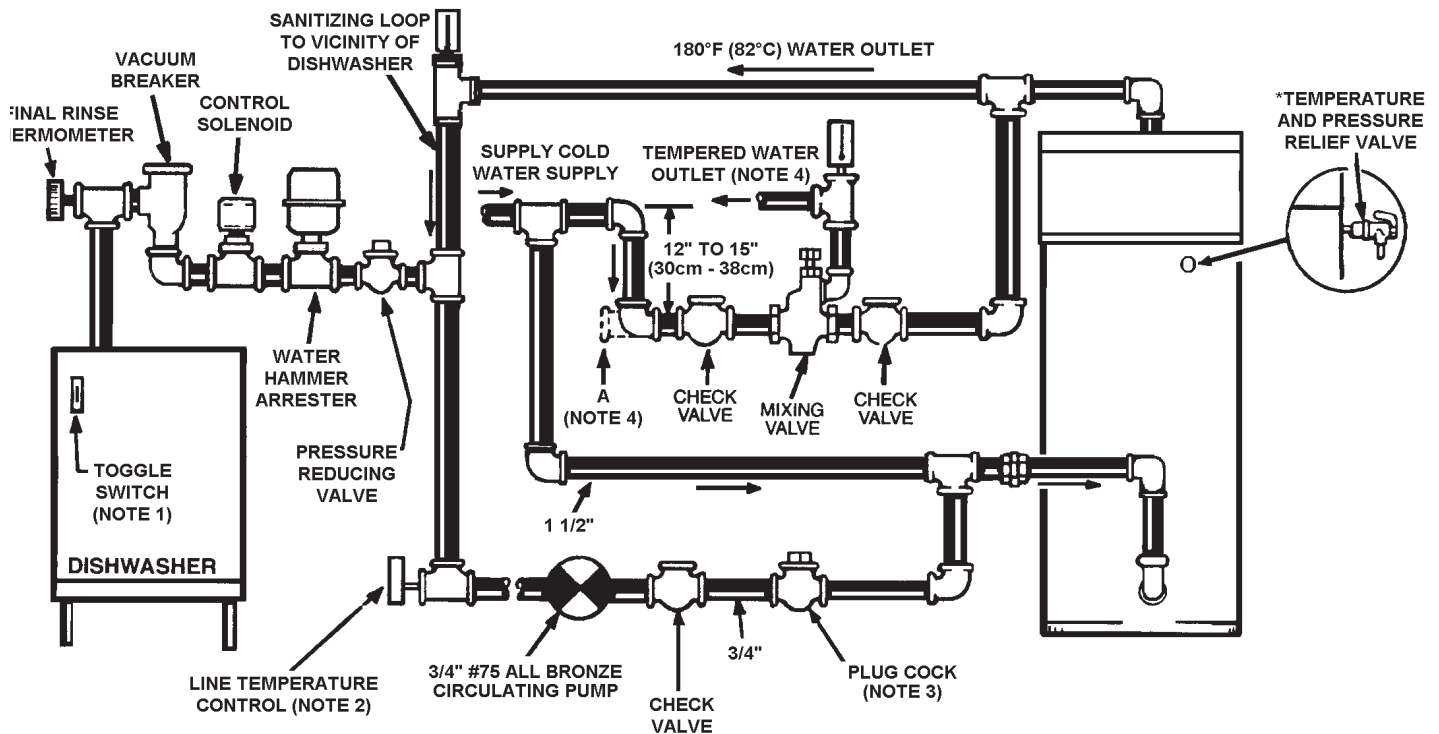

⚠ DANGER

TEMPERATURE SETTING SHOULD NOT EXCEED SAFE TEMPERATURE AT FIXTURES. SEE WATER TEMPERATURE CONTROL WARNING ON PAGE 5. IF HIGHER PREHEAT TEMPERATURES ARE NECESSARY TO OBTAIN ADEQUATE BOOSTER OUTPUT, ADD AN ANTI-SCALD VALVE FOR HOT WATER SUPPLIED TO FIXTURES.

CAUTION: IF BUILDING COLD WATER SUPPLY HAS A BACK-FLOW PREVENTER, CHECK VALVE OR WATER METER WITH CHECK VALVE PROVISIONS FOR THERMAL EXPANSION OF WATER IN THE HOT WATER SYSTEM MUST BE PROVIDED.

*PIPE RELIEF VALVE TO OPEN DRAIN

INSTALL IN ACCORDANCE WITH LOCAL CODES

NOTE 1: TOGGLE SWITCH CONTROLS 180°F (82°C) WATER CIRCULATION. INSTALL ON OR CLOSE TO DISHWASHER. TOGGLE SWITCH MUST BE CLOSED (ON) DURING THE RINSE OPERATION AND OPEN (OFF) WHEN DISHWASHER IS NOT OPERATING OR WHEN ON LONG STANDBY.

NOTE 2: INSTALL LINE TEMPERATURE CONTROL IN AN UNINSULATED TEE BEYOND THE DISHWASHER TAKEOFF IN THE SANITIZING LOOP. CONTROL SHOULD BE SET AT 185°F (85°C).

NOTE 3: ADJUST PLUG COCK SO THE SANITIZING LOOP FLOW RATE DOES NOT CAUSE UNNECESSARY TURBULENCE IN THE TANK.

NOTE 4: IF TEMPERED WATER IS RECIRCULATED, RETURN LINE SHOULD BE CONNECTED AT POINT A.

MANIFOLD KITS

Precision cut type "L" all copper State manifold kits assure water flow balance of all units. Without this balance, the full water heating and storage potential of the system cannot be achieved. Plus, the units with the higher water flow may have a shortened life.

Dimensions shown are for minimum space occupied by the water heaters assemblies.

Space for the venting system and unit servicing must be added.

TWO UNIT MANIFOLD

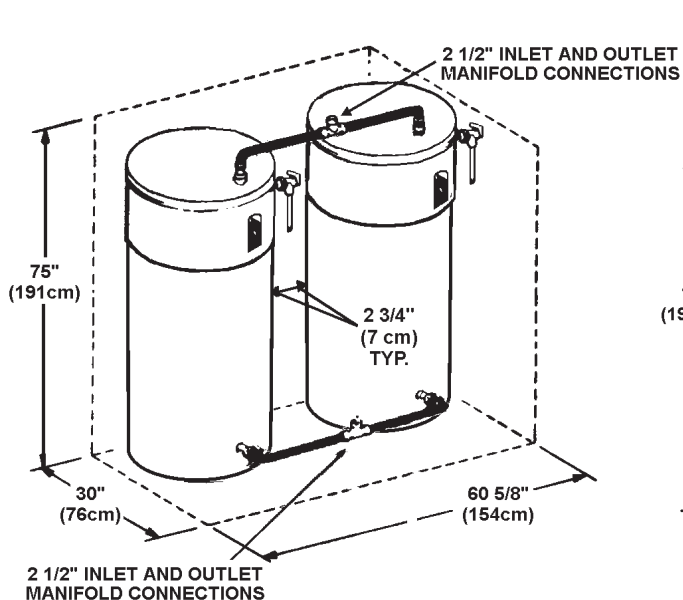

THREE UNIT MANIFOLD

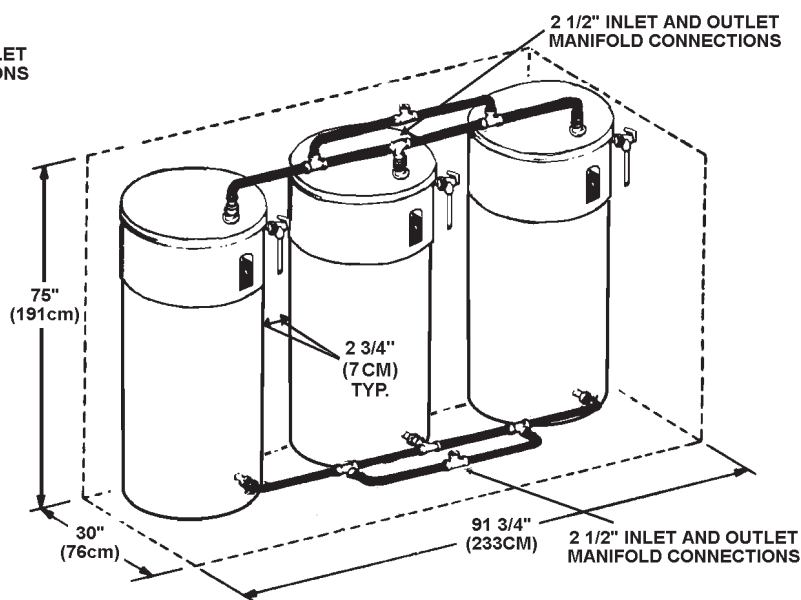

CAUTION: IF THE PLUMBING REQUIRES THE USE OF PIPES WITH DISSIMILAR MATERIAL (FOR EXAMPLE, STEEL AND COPPER), USE DIELECTRIC UNIONS TO PREVENT AN ELECTRO-GALVANIC ACTION BETWEEN THE PIPING COMPONENTS WITH DISSIMILAR MATERIALS.

FOUR UNIT MANIFOLD

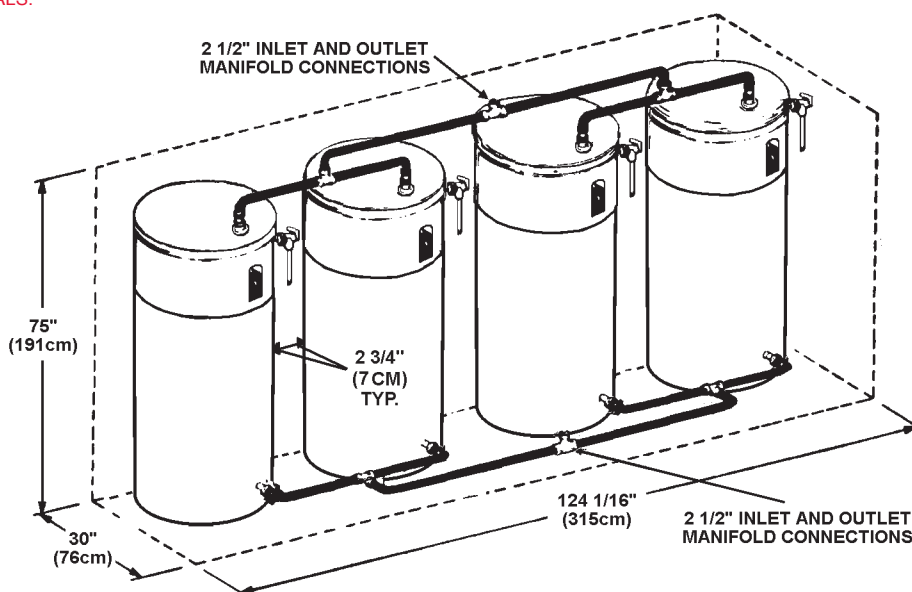

CHECKLIST AND SERVICE INFORMATION

IMPORTANT

The installer may be able to observe and correct certain problems which might arise when the unit is put into operation or when it is re-fired after a prolonged shutdown. HOWEVER, it is recommended that only qualified servicemen, using appropriate test equipment, be allowed to service the heater.

BE SURE TO TURN OFF THE ELECTRICITY WHENEVER POSSIBLE OR APPROPRIATE WHILE CHECKING EQUIPMENT.



WARNING

FAILURE TO FOLLOW THESE INSTRUCTIONS CAN RESULT IN SERIOUS PERSONAL INJURY OR DEATH.

CAUTION: LABEL ALL WIRES PRIOR TO DISCONNECTION WHEN SERVICING CONTROLS. WIRING ERRORS CAN CAUSE IMPROPER AND DANGEROUS OPERATION.

VERIFY PROPER OPERATION AFTER SERVICING.

BURNER OPERATIONAL PROBLEMS

1. Refer to TROUBLESHOOTING.

NOT ENOUGH OR NO HOT WATER

1. Be certain the electrical disconnect switch serving the water heater is in the ON position.
2. Check the fuses.
 - The electrical disconnect switch usually contains fuses.
3. The capacity of the heater may have been exceeded by a large demand for hot water.
 - Large demands require a recovery period to restore water temperature.
4. Colder incoming water temperature will lengthen the time required to heat water to the desired temperature.
 - If the heater was installed when incoming water temperature was warm, colder water creates the effect of less hot water.
5. Look for hot water wastage and leaking or open hot water faucets.
6. Sediment or lime scale may be affecting water heater operation. Refer to MAINTENANCE for details.
7. Burner may not be firing at proper rate.
 - Check gas pressure. Adjust to obtain required manifold pressure.
8. Burner fan wheel may be dirty.
 - Clean fan wheel with a stiff brush.
9. Condensate hose may be blocked where it connects to the exhaust elbow.
 - Verify the condensate drains from the unit without restriction.

WATER IS TOO HOT

1. Refer to WATER TEMPERATURE CONTROL.

WATER HEATER MAKES SOUNDS

1. Sediment or lime scale accumulations cause rumbling and pounding noises when the heater is operating.
 - The sounds are normal, however, the tank bottom should be cleaned. Refer to MAINTENANCE for details.

2. Some of the electrical components of the water heater make sounds which are normal.

- Contacts click or snap as the heater starts and stops.
- Transformers often hum.

WATER LEAKAGE IS SUSPECTED

1. Check to see if the water heater drain valve is tightly closed. Also check the cleanout opening for leakage.
2. The apparent leakage may be condensation which forms on cool surfaces of the heater and piping.
3. If the outlet of the relief valve is leaking it may represent:
 - Excessive water pressure.
 - Excessive water temperature.
 - Faulty relief valve.

Excessive water pressure is the most common cause of relief valve leakage. It is often caused by a "closed system". If a check valve is in the inlet system it will not permit the expanded hot water volume to equalize pressure with the main. The relief valve must release this water or the water heater or plumbing system will be damaged. Refer to MAINTENANCE-RELIEF VALVE section in this manual.

When such a condition is encountered, local codes or inspection agency should be consulted to determine which system is acceptable in your area. See CLOSED SYSTEM section in this manual also.

TROUBLE-SHOOTING

1. Verify that the allowable vent length has not been exceeded and that the blower inlet screen has been removed if direct venting.
2. Verify that the condensation, which WILL be present in the heater and exhaust vent, will drain.
3. Check supply wire polarity - hot to hot and neutral to neutral and no "stray" current in neutral.
4. Heater is properly grounded.

Checking these four (4) items first will often result in a timely solution to the service call.



WARNING

JUMPING OUT COMPONENTS AND/OR CIRCUITS DURING TROUBLESHOOTING CAN CAUSE SERIOUS PROBLEMS WITH THE UNIT'S OPERATING SEQUENCE AND IGNITION SAFETY. IF YOU DO NOT HAVE THE PROPER TEST EQUIPMENT, I.E. A VOLT-OHM METER AND A MICROAMMETER, DO NOT ATTEMPT TO TROUBLESHOOT OR REPAIR STATE EQUIPMENT.

ALTERING THE CONTROLLER AND/OR CONTROLLER WIRING IN ANY WAY COULD RESULT IN INTERNAL DAMAGE TO THE MODULE CIRCUITS, POSSIBLY ALTERING THE IGNITION SEQUENCE ALLOWING GAS VALVES TO OPEN BEFORE THE HOT SURFACE IGNITER IS UP TO IGNITION TEMPERATURE.

NOTE: ANY BYPASS OR ALTERATION OF THE UNITS SAFETIES WILL RESULT IN VOIDING THE APPLIANCE WARRANTY.

Before performing any troubleshooting familiarize yourself with the particular appliance.

Refer to the connection diagram located on page 15 before continuing.

Make sure the appliance is connected to a 120V AC power supply, manual gas valve is in the ON position, and all electrical connections are secure before continuing to troubleshoot this appliance.



CAUTION

THE WATER HEATER IS POLARITY SENSITIVE. BEFORE APPLYING ELECTRICITY TO THIS HEATER BE CERTAIN THAT SUPPLY HEATED WIRE TO GROUND CHECK INDICATES ZERO VOLTAGE.

MOTOR WILL NOT RUN

1. Confirm 120V AC to the controller. Also, to verify correct polarity, check for 120 V AC between hot supply and ground.

If there is no voltage, check for a loose connection where it connects to the controller.

2. If there is 120 volts to the controller, check for loose connections or a locked rotor. If the rotor cannot be freed the motor and blower assembly must be replaced.

MOTOR RUNS, PREPURGE TIME ELAPSES BUT MAIN FLAME NOT ESTABLISHED.

1. Check to see if main manual gas valve is open.
2. Check for a loose connection at the transformer, or a defective transformer.
3. Check for a loose connection at the gas valve.
4. Check for open pressure switches or open reset button. Check for blockage in the intake and exhaust venting or at the vent hoods. If no blockage is found, check vinyl tubing for cuts or crimps. If this tubing is damaged it must be replaced. If these steps do not eliminate the problem, replace the pressure switches.
5. Check to see if there is resistance across the igniter terminal with an OHM meter. If there is no continuity, the igniter is broken and should be replaced.

If the igniter appears to function properly, then verify that the inlet pressure is within the range shown in Table 4. The gas valve supplied on the appliance is not designed to open against a higher inlet pressure of 10.5"WC (2.59kPa) for natural gas and 14.0"WC (3.45kPa) for propane gas. At this time, also check to make sure the inlet pressure is not lower than 4.0"WC (.98kPa) for natural gas and 11.0"WC (2.74kPa) for propane gas. If the inlet pressure is not within these limits then adjust the supply pressure accordingly.

If the inlet pressure falls within the allowable limits, then verify that the manifold pressure, when the gas is fully open, with the heater running, is as called out in Table 4: that is, 0"WC (0kPa) for both natural and propane gas. If the manifold pressure is not correct then adjust accordingly. See "ADJUSTMENT PROCEDURE" in "OPERATING INSTRUCTIONS" sections for manifold pressure adjustment procedure.

6. If the inlet and manifold pressures are within the limits specified in step 5, then reset the appliance. Verify 24V AC at the gas valve during the three (3) second ignition trial, after the igniter reaches operating temperature. If 24V AC at the gas valve is not seen during this period, the controller must be replaced.

If there is 24V AC at the gas valve during the four second ignition trial and the manifold pressure does not increase above 0" W.C. then verify that the manual gas control valve is in the "ON" position (see page 20). If the valve is in the "ON" position and the previous voltage and gas pressure conditions are met, then the gas valve is defective and must be replaced.

Note that a positive manifold pressure reading of approximately 1.5" (.38 kPa) W.C. is normal during the prepurge portion of the ignition cycle due to the location of the gas orifice.

MOTOR RUNS, BURNER LIGHTS MOMENTARILY, THEN LOCKS OUT

1. Reset the appliance two more times to ensure that all of the air has been purged from the gas line.
2. If the burner lights momentarily but does not sustain ignition, verify that the inlet pressure is not greater than 10.5" WC (2.59 kPa) for natural gas and 14.0" WC (3.45 kPa) for propane gas or lower than the minimal supply pressure which is 4.0" WC (.09kPa) for natural gas and 11.0"WC (2.74 kPa) for propane gas. Also, verify that the manifold pressure is correct, that is, 0"WC (0kPa) for both natural and propane gas 199 models. If the manifold pressure is not correct then adjust accordingly. See "ADJUSTMENT PROCEDURE" in "OPERATING INSTRUCTIONS" sections for manifold pressure adjustment procedure.
3. Check for the reversed polarity in the supply wiring. This controller is polarity sensitive. If the hot and neutral supply wires are reversed, the controller will not sense flame. Reverse the supply wires and try to fire the unit.

NOTE: Always turn off and disconnect main supply wiring before servicing the unit.

4. Check connecting wire to the flame sensor. Verify that the flame sensor has not been damaged in any way.
5. Verify that the air supply is adequate. The air inlet screen or blower wheel may be restricted. Also, check the installation for proper ventilation. See AIR REQUIREMENTS.
6. Check the venting system for the correct sizing, excess or insufficient. See VENTING.
7. Check for maximum inlet pressure of 10.5"WC (2.59 kPa) for natural gas and 14.0"WC (3.45 kPa) for propane gas and the manifold pressure which is 0"WC (0 kPa) for both natural and propane gas 199 models. Please note that the manifold pressure listed is the maximum value for the manifold pressure. Do not set the manifold pressure higher than the value show in Table 4. OVER FIRING the heater will result in a rough ignition and/or noisy operation.
8. Confirm that the air inlet screen (see Figures 7 & 8) is free of obstructions.

CAUTION

Do not reach into the burner housing or combustion chamber if the heater is still hot. Allow the heater to cool and always use gloves as the combustion chamber and the burner sleeve and housing can become very hot after operation. OVER FIRING is a dangerous condition that must be corrected immediately.

GAS FAILS TO SHUT OFF

Check for defective gas valve or thermostat. If operation is incorrect, replace.

REPLACEMENT PARTS

Replacement parts may be ordered through authorized dealers, servicers, or distributors. Refer to the Yellow Pages for where to call or contact 1-800-821-2017. When ordering parts be sure to state the quantity, part number and description of the items including the complete model and serial number as it appears on the product. Refer to the parts list for more information.

NOTES:

NOTES:

MODEL RUF LIMITED WARRANTY

The warrantor extends the following LIMITED WARRANTY to the owner of this water heater.

1. THE TANK

If the glass-lined tank in this water heater shall prove upon examination by the warrantor to have leaked due to natural corrosion from potable water therein, during the first THREE years after initial installation, the warrantor will supply a replacement tank less burner and controls or a complete new water heater of equivalent size and current model at the warrantor's option. Some government agencies are requiring energy efficient standards for water heaters. In the event regulations prohibit sale of a model of equivalent size and construction, the warrantor will provide a model which complies with the regulations of your area, in which case the consumer will be charged the difference in price between the like replacement and the energy efficient model required. The warranty on the replacement water heater will be limited to the unexpired term of the original warranty.

2. ALL OTHER PARTS

If within ONE year after initial installation of this water heater, any part or portion shall prove upon examination by the warrantor to be defective in material or workmanship, the warrantor will repair or replace such part or portion at its option.

3. CONDITIONS AND EXCEPTIONS

This warranty shall apply only when the water heater is installed in accordance with local plumbing and building codes, ordinances and regulations, the printed instructions provided with it and good industry practices. In addition, a temperature and pressure relief valve, certified by CSA and approved by the American Society of Mechanical Engineers, must have been installed.

a. This warranty shall apply only when the heater is used:

- (1) at temperatures not exceeding the maximum setting of its thermostat;
- (2) at water pressure not exceeding the working pressure shown on the heater;
- (3) when operated free of the damaging effects of uncontrolled water hammer;
- (4) when filled with potable water, free to circulate at all times;
- (5) in a non-corrosive and non-contaminated atmosphere;
- (6) with factory approved anode(s) installed;
- (7) in the United States, its territories or possessions, and Canada;
- (8) sized in accordance with proper sizing techniques for commercial and/or residential water heaters;
- (9) bearing a rating plate which has not been altered, defaced or removed, except as required by the warrantor;
- (10) operated with properly installed dirt leg;
- (11) fired with the fuel for which it was factory built;
- (12) fired at the factory rated input;

b. Any accident to the water heater, any misuse, abuse (including freezing) or alteration of it, any operation of it in a modified form, or any attempt to repair tank leaks will void this warranty.

c. This warranty is void if a device acting as a backflow prevention device (check valves etc.) is installed in the cold water supply the heater is connected to, unless an effective method of controlling thermal expansion is also installed at the heater(s) and operational at all times. The relief valve installed on the heater is not an acceptable method.

d. This warranty shall be void and shall have no effect if the design or structure of the water heater is, or is attempted to be modified or altered in any way, including, but not limited to, by attaching non-company approved appliances or equipment.

4. SERVICE AND REPAIR EXPENSES

Under the limited warranty the warrantor will provide only a replacement water heater or part thereof. The owner is responsible for all other costs. Such costs may include but are not limited to:

- a. Labor charges for service removal, repair or reinstallation of the water heater or any component part;
- b. Shipping, delivery, handling, and administrative charges for forwarding the new heater or replacement part from the nearest distributor and returning the claimed defective heater or part to such distributor.
- c. All cost necessary or incidental for any material and/or permits required for installation of the replacement.

5. LIMITATIONS ON IMPLIED WARRANTIES

Implied warranties, including the warranty of merchantability imposed on the sale of this heater under state law are limited to one (1) year duration for the heater or any of its parts. Some states do not allow limitations on how long an implied warranty lasts, so the above limitation may not apply to you.

6. CLAIM PROCEDURE

Any claim under the warranty should be initiated with the dealer who sold the boiler, or with any other dealer handling the warrantor's products. If this is not practicable, the owner should contact:

U.S. Customers
Telephone: 1-(800)-365-0024

- a. The warrantor will only honor replacement with identical or similar water heater or parts thereof which are manufactured or distributed by the warrantor.
- b. Dealer replacements are made subject to in-warranty validation by warrantor.

7. DISCLAIMERS

NO OTHER EXPRESS WARRANTY HAS BEEN OR WILL BE MADE IN BEHALF OF THE WARRANTOR WITH RESPECT TO THE MERCHANTABILITY OF THE HEATER OR THE INSTALLATION, OPERATION, REPAIR OR REPLACEMENT OF THE BOILER. THE WARRANTOR SHALL NOT BE RESPONSIBLE FOR WATER DAMAGE, LOSS OF USE OF THE UNIT, INCONVENIENCE, LOSS OR DAMAGE TO PERSONAL PROPERTY OR OTHER CONSEQUENTIAL DAMAGE. THE WARRANTOR SHALL NOT BE LIABLE BY VIRTUE OF THIS WARRANTY OR OTHERWISE FOR DAMAGE TO ANY PERSONS OR PROPERTY, WHETHER DIRECT OR INDIRECT, AND WHETHER ARISING IN CONTRACT OR TORT.

- a. Some states do not allow the exclusion or limitation of the incidental or consequential damage, so the above limitations or exclusions may not apply to you.
- b. This warranty gives you specific legal rights, and you may also have other rights which vary from state to state.

Fill in the following for your own reference. Keep it. Registration is not a condition of warranty. The model and serial number are found on the heater's rating plate.

Model No. _____ Serial No. _____ Date Installed _____

Dealer's Name _____

Dealer's Address _____ Phone No. _____

City and State _____ Zip Code _____

KEEP THIS WARRANTY POSTED ADJACENT TO THE HEATER FOR FUTURE REFERENCE

Free Manuals Download Website

<http://myh66.com>

<http://usermanuals.us>

<http://www.somanuals.com>

<http://www.4manuals.cc>

<http://www.manual-lib.com>

<http://www.404manual.com>

<http://www.luxmanual.com>

<http://aubethermostatmanual.com>

Golf course search by state

<http://golfingnear.com>

Email search by domain

<http://emailbydomain.com>

Auto manuals search

<http://auto.somanuals.com>

TV manuals search

<http://tv.somanuals.com>