

M38D29T2-RLFS

Emulator MCU Board for 38D2 Group

User's Manual

Notes regarding these materials

1. This document is provided for reference purposes only so that Renesas customers may select the appropriate Renesas products for their use. Renesas neither makes warranties or representations with respect to the accuracy or completeness of the information contained in this document nor grants any license to any intellectual property rights or any other rights of Renesas or any third party with respect to the information in this document.
2. Renesas shall have no liability for damages or infringement of any intellectual property or other rights arising out of the use of any information in this document, including, but not limited to, product data, diagrams, charts, programs, algorithms, and application circuit examples.
3. You should not use the products or the technology described in this document for the purpose of military applications such as the development of weapons of mass destruction or for the purpose of any other military use. When exporting the products or technology described herein, you should follow the applicable export control laws and regulations, and procedures required by such laws and regulations.
4. All information included in this document such as product data, diagrams, charts, programs, algorithms, and application circuit examples, is current as of the date this document is issued. Such information, however, is subject to change without any prior notice. Before purchasing or using any Renesas products listed in this document, please confirm the latest product information with a Renesas sales office. Also, please pay regular and careful attention to additional and different information to be disclosed by Renesas such as that disclosed through our website. (<http://www.renesas.com>)
5. Renesas has used reasonable care in compiling the information included in this document, but Renesas assumes no liability whatsoever for any damages incurred as a result of errors or omissions in the information included in this document.
6. When using or otherwise relying on the information in this document, you should evaluate the information in light of the total system before deciding about the applicability of such information to the intended application. Renesas makes no representations, warranties or guaranties regarding the suitability of its products for any particular application and specifically disclaims any liability arising out of the application and use of the information in this document or Renesas products.
7. With the exception of products specified by Renesas as suitable for automobile applications, Renesas products are not designed, manufactured or tested for applications or otherwise in systems the failure or malfunction of which may cause a direct threat to human life or create a risk of human injury or which require especially high quality and reliability such as safety systems, or equipment or systems for transportation and traffic, healthcare, combustion control, aerospace and aeronautics, nuclear power, or undersea communication transmission. If you are considering the use of our products for such purposes, please contact a Renesas sales office beforehand. Renesas shall have no liability for damages arising out of the uses set forth above.
8. Notwithstanding the preceding paragraph, you should not use Renesas products for the purposes listed below:
 - (1) artificial life support devices or systems
 - (2) surgical implantations
 - (3) healthcare intervention (e.g., excision, administration of medication, etc.)
 - (4) any other purposes that pose a direct threat to human life

Renesas shall have no liability for damages arising out of the uses set forth in the above and purchasers who elect to use Renesas products in any of the foregoing applications shall indemnify and hold harmless Renesas Technology Corp., its affiliated companies and their officers, directors, and employees against any and all damages arising out of such applications.
9. You should use the products described herein within the range specified by Renesas, especially with respect to the maximum rating, operating supply voltage range, movement power voltage range, heat radiation characteristics, installation and other product characteristics. Renesas shall have no liability for malfunctions or damages arising out of the use of Renesas products beyond such specified ranges.
10. Although Renesas endeavors to improve the quality and reliability of its products, IC products have specific characteristics such as the occurrence of failure at a certain rate and malfunctions under certain use conditions. Please be sure to implement safety measures to guard against the possibility of physical injury, and injury or damage caused by fire in the event of the failure of a Renesas product, such as safety design for hardware and software including but not limited to redundancy, fire control and malfunction prevention, appropriate treatment for aging degradation or any other applicable measures. Among others, since the evaluation of microcomputer software alone is very difficult, please evaluate the safety of the final products or system manufactured by you.
11. In case Renesas products listed in this document are detached from the products to which the Renesas products are attached or affixed, the risk of accident such as swallowing by infants and small children is very high. You should implement safety measures so that Renesas products may not be easily detached from your products. Renesas shall have no liability for damages arising out of such detachment.
12. This document may not be reproduced or duplicated, in any form, in whole or in part, without prior written approval from Renesas.
13. Please contact a Renesas sales office if you have any questions regarding the information contained in this document, Renesas semiconductor products, or if you have any other inquiries.



CAUTION

If the requirements shown in the "CAUTION" sentences are ignored, the equipment may cause personal injury or damage to the products.

Renesas Tools Homepage <http://www.renesas.com/tools>

1. Outline

The M38D29T2-RLFS is an emulator MCU board for the 38D2 Group.

2. Package Components

- (1) M38D29T2-RLFS 1 pc.
- (2) M38D29T2-RLFS User's Manual (This manual) 1 pc.
- (3) M38D29T2-RLFS User's Manual (Japanese) 1 pc.

The M3T-F160-64NSA is included with the M38D29T2-RLFS-FP.
 The M3T-F160-64NSD is included with the M38D29T2-RLFS-HP.
 For details on the M3T-F160-64NSA and M3T-F160-64NSD, refer to each user's manual.

3. Specifications

Table 1 Specifications

Emulator	M38000T2-CPE PC4701 + M38000TL2-FPD
Operation mode	Single-chip mode
Max. operating frequency	Vcc = 4.5 to 5.5V: 12.5MHz (frequency/2 mode) Vcc = 4.0 to 5.5V: 8.0MHz (frequency/2 mode) Vcc = 2.0 to 5.5V: 4.0MHz (frequency/2 mode) Vcc = 1.8 to 5.5V: 2.0MHz (frequency/2 mode) Vcc = 4.5 to 5.5V: 16.0MHz (frequency/4 mode) Vcc = 3.1 to 5.5V: 12.5MHz (frequency/4 mode) Vcc = 2.0 to 5.5V: 8.0MHz (frequency/4 mode) Vcc = 1.8 to 5.5V: 4.0MHz (frequency/4 mode) Vcc = 4.5 to 5.5V: 16.0MHz (frequency/8 mode) Vcc = 2.0 to 5.5V: 12.5MHz (frequency/8 mode) Vcc = 1.8 to 5.5V: 8.0MHz (frequency/8 mode) Vcc = 1.8 to 5.5V: Low-speed mode
Operating power voltage	1.8 to 5.5 V

4. Connecting the User System

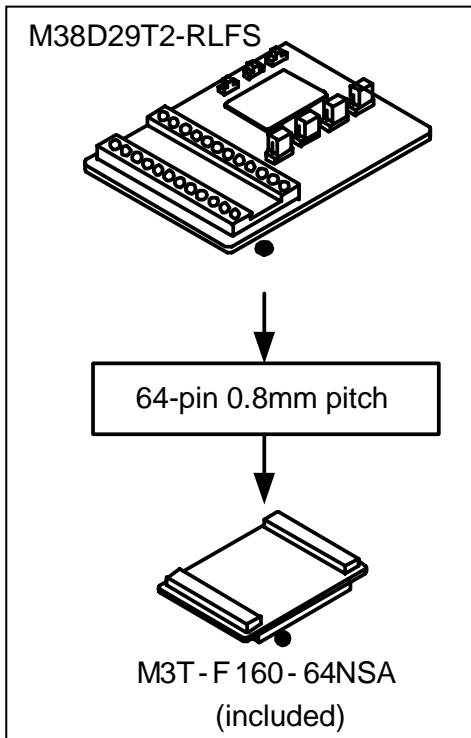

Figure 1 M38D29T2-RLFS-FP

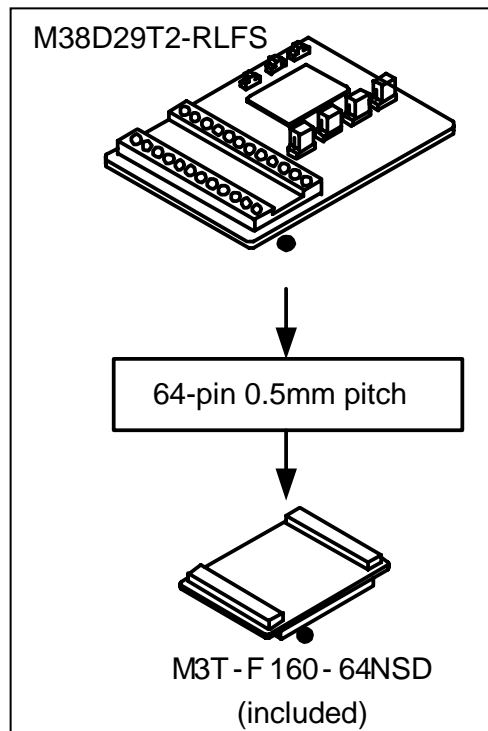

Figure 2 M38D29T2-RLFS-HP

5. Connection Procedure

(1) For M38D29T2-RLFS-FP

- 1 Mount the NQPACK064SA160 to the foot pattern of the user system.
- 2 Attach the included M3T-F160-64NSA to the M38D29T2-RLFS.
- 3 Mount the YQPACK064SA on the NQPACK064SA160.
- 4 Attach the tip of the probe of the emulator to the M38D29T2-RLFS, and connect the M38D29T2-RLFS and YQPACK064SA.

(2) For M38D29T2-RLFS-HP

- 1 Mount the NQPACK064SD-ND to the foot pattern of the user system.
- 2 Attach the included M3T-F160-64NSD to the M38D29T2-RLFS.
- 3 Mount the YQPACK064SD on the NQPACK064SD-ND.
- 4 Attach the tip of the probe of the emulator to the M38D29T2-RLFS, and connect the M38D29T2-RLFS and YQPACK064SD.

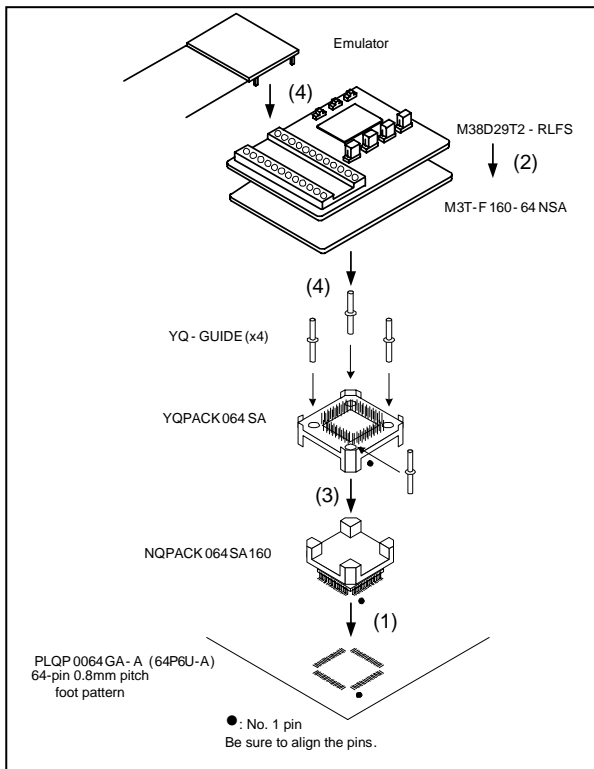

Figure 3 Connection procedure of M38D29T2-RLFS-FP

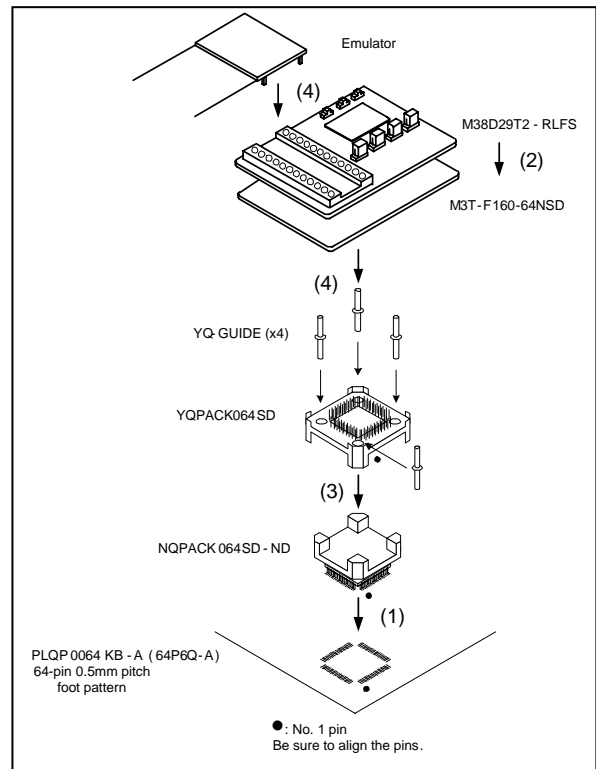

Figure 4 Connection procedure of M38D29T2-RLFS-HP

6. External Dimensions

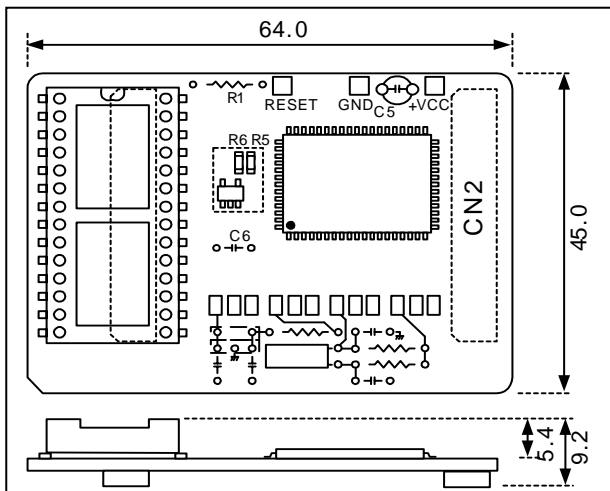

Figure 5 External dimensions

7. Oscillator Circuit

This product has two oscillator circuit patterns for the main clock XIN and sub-clock XCIN. Figures 6 and 7 show the oscillator circuit diagram and oscillator circuit pattern, respectively. Select one of them according to the oscillator circuitry of the user system.

(1) When using the internal oscillator circuit of the MCU:

The oscillator circuit on the user system may not oscillate because a converter board is used between the emulator MCU and the user system. In this case, set the jumper switch to INT and mount an oscillator circuit on the M38D29T2-RLFS's oscillator circuit pattern. When using the oscillator circuit on the user system, be sure to set the jumper switch to EXT.

(2) When using an oscillator module IC etc. (self-oscillation):

It is not necessary to mount an oscillator circuit on the M38D29T2-RLFS's oscillator circuit pattern.

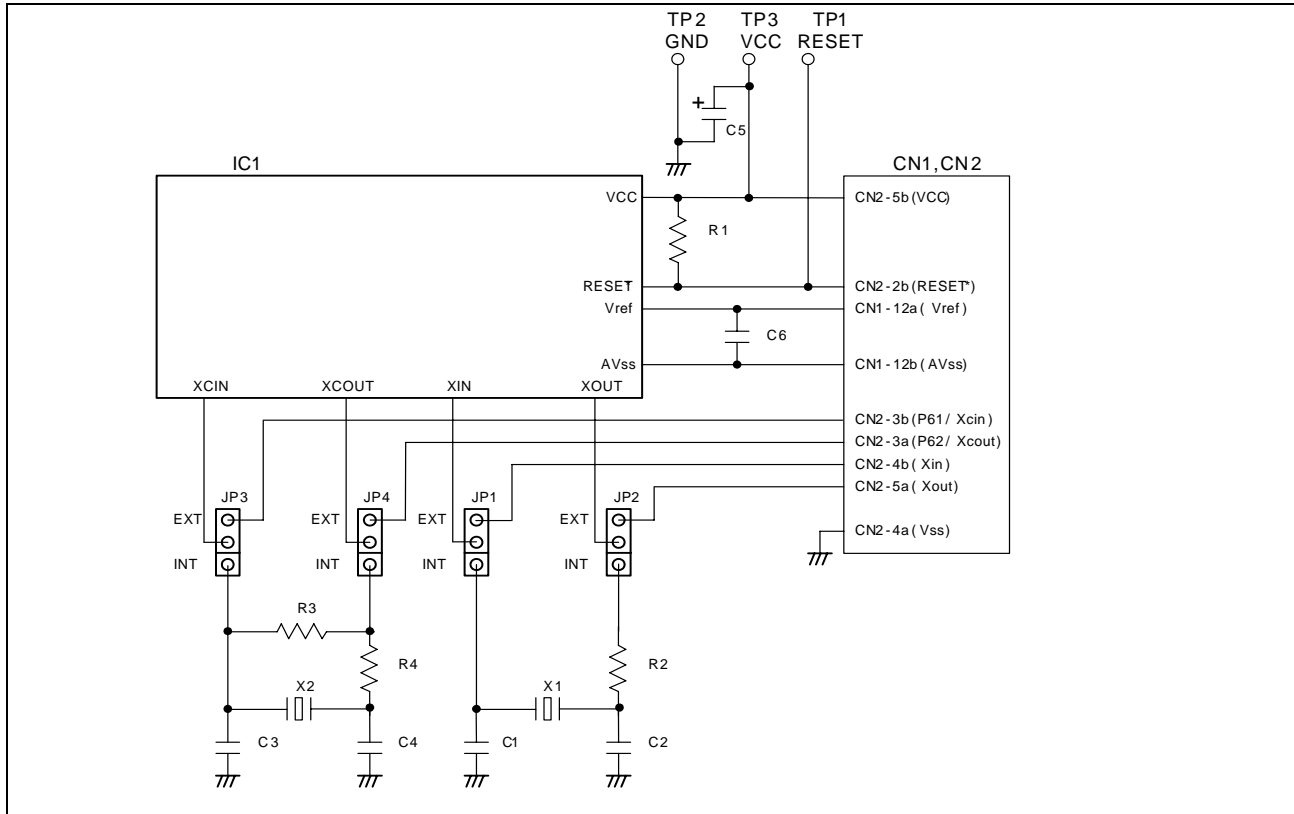

Figure 6 Oscillator circuit diagram

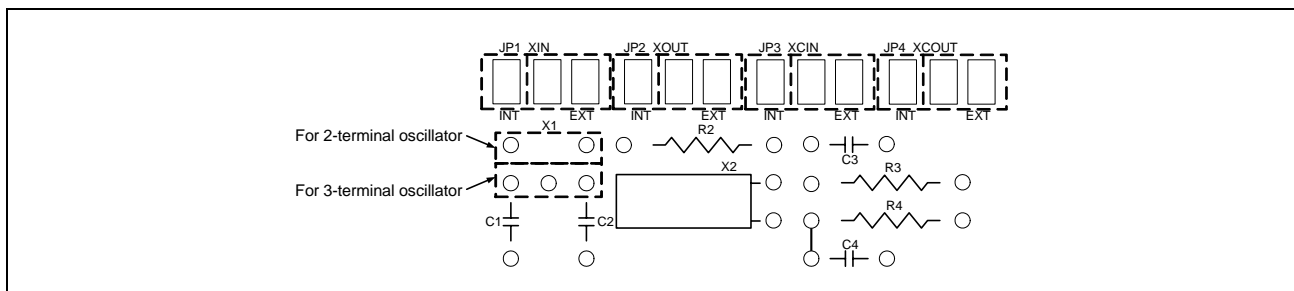

Figure 7 Oscillator circuit pattern

8. Precautions

IMPORTANT

Notes on This Product:

- We cannot accept any request for repair.
- When using the oscillator circuit on the M38D29T2-RLFS, check the output waveform of pins Xout and Xcout by an oscilloscope.
- When mounting an oscillator circuit on the M38D29T2-RLFS, make sure that 2 mm or more of a DIP pin does not appear on the rear face (solder side). It may be short-circuited with the DIP pin of the converter board.
- For inquiries about the product or the contents of this manual, contact your local distributor.

Renesas Tools Homepage

<http://www.renesas.com/tools>

Free Manuals Download Website

<http://myh66.com>

<http://usermanuals.us>

<http://www.somanuals.com>

<http://www.4manuals.cc>

<http://www.manual-lib.com>

<http://www.404manual.com>

<http://www.luxmanual.com>

<http://aubethermostatmanual.com>

Golf course search by state

<http://golfingnear.com>

Email search by domain

<http://emailbydomain.com>

Auto manuals search

<http://auto.somanuals.com>

TV manuals search

<http://tv.somanuals.com>