

Revolabs HD™ Single/Dual Wireless Microphone System

Models: 02-HDSGL, 02-HDDUAL, 04-HDSGLEU and 04-HDDUALEU



User and Set-up Guide



© 2009 REVOLABS, INC. All rights reserved. No part of this document may be reproduced in any form or by any means without express written permission from Revolabs, Inc. Product specifications are subject to change without notice.

Revolabs HD™ Single & Dual Manual
01-HDSGLMAN-PAP-11
March 2010 (Rev 1.6)



Contents

Safety and General Information	1
Introduction.....	3
System Components	3
Installing the Revolabs HD™ Base Station.....	4
Controls and Connections:	4
Configuring the Revolabs HD™ Base Station.....	5
Using the Rear Panel Configuration DIP Switches	6
Revolabs HD Microphones and HD Microphone Adapters.....	7
Using the HD Wearable Wireless Microphones	7
Using the HD Omni-Directional Tabletop Wireless Boundary Microphones	9
Using the HD Directional Tabletop Wireless Boundary Microphones	10
Using the HD XLR Microphone Wireless Adapter	11
Using the HD Wireless Adapter for Countryman Microphone	12
Pairing Wireless Microphones to Base Station.....	13
Revolabs HD™ Single or Dual Charger Base.....	14
Power Module	14
Charging the Microphone Batteries	14
Updating the Revolabs HD™ Firmware	15
Revolabs HD™ Indicator LEDs.....	16
Warranty.....	17
Specifications	18
Index.....	19

Safety and General Information

Please read the following information to ensure safe and efficient use of your Revolabs system.

FCC User Information

FCC Registration Number: 0014898290

FCC ID: T5V02HDTRX Revolabs HD™ Dual Base Station

FCC ID: T5V01HDEXEMIC Revolabs Executive HD™ Microphone

FCC Notice to Users

Users are not permitted to make changes or modify the equipment in any way. Changes or modifications not expressly approved by Revolabs, Inc. could void the user's authority to operate the equipment.

This device complies with Part 15 of the FCC Rules. Operation is subject to the following two conditions: (1) this device may not cause harmful interference, and (2) this device must accept any interference received, including interference that may cause undesired operation.

IMPORTANT NOTE: Federal Communications Commission (FCC) Radiation Exposure Statement

This equipment complies with FCC radiation exposure limits for an uncontrolled environment.

Professional Installation Recommended

This product should be professionally installed.

Industry Canada Notice to Users

Operation is subject to the following two conditions:

(1) This device may not cause interference and

(2) This device must accept any interference, including interference that may cause undesired operation of the device

IC: 6455A-02HDDUALNM Revolabs HD™ Dual Base Station

IC: 6455A-01HDEXEMIC Revolabs Executive HD™ Microphone

Restricted use with certain medical devices

Hearing Aids

Some devices may interfere with some hearing aids. In the event of such interference, you may want to consult with your hearing aid manufacturer to discuss alternatives.

Other Medical Devices

If you use any other personal medical device, consult the manufacturer of your device to determine if it is adequately shielded from RF energy. Your physician may be able to assist you in obtaining this information.

Export Law Assurances

This product is controlled under the export regulations of the United States of America and Canada. The Governments of the United States of America and Canada may restrict the exportation or re-exportation of this product to certain destinations. For further information contact the U.S. Department of Commerce or the Canadian Department of Foreign Affairs and International Trade. The use of wireless devices and their accessories may be prohibited or restricted in certain areas. Always obey the laws and regulations on the use of these products.

02-HDSGL and 02-HDDUAL (1 & 2 channel systems respectively) North America UPCS Usage Restriction

Due to the UPCS frequencies used, this product is licensed for operation only in the United States of America and Canada.

04-HDSGLEU and 04-HDDUALEU (1 & 2 channel systems respectively) European Union Usage Restriction

Due to the DECT frequencies used, this product is licensed for operation only in the European Union countries.

European Compliance

This equipment has been approved in accordance with Council Directive 1999/5/EC "Radio Equipment and telecommunications Equipment.



Model Numbers:

04-HDSGLEU-NM	HD Single Channel System, 1-Channel, w/o mics
04-HDDUALEU-NM	HD Dual Channel System 2-Channel, w/o mics
03-HDEXEMICEU-11	HD Microphone, Wearable
03-HDTBLMICEU-OM-11	HD Microphone, Tabletop, Omni-directional
03-HDTBLMICEU-DR-11	HD Microphone, Tabletop, Directional
03-HDXLRMICEU-11	HD, XLR Wireless Adapter for Dynamic Handheld Microphone
03-HDCOMANEU-11	HD Wireless Adapter for Countryman Microphone

Standards to which Conformity is declared:

RF ETSI EN 301 406 V 1.4.1 03/2001
EMC ETSI EN 301 489-6 v1.2.1 (2002-04)

WEEE Notification:

The Waste Electrical and Electronic Equipment (WEEE) directive (2002/96/EC) is intended to promote recycling of electrical and electronic equipment and their components at end of life.



2003/11/EC & 2002/95/EC "RoHS Compliance Directive":

The products referenced herein are in compliance with the EU directive 2003/11/EC and EU directive 2002/95/EC.

Introduction

Congratulations on your purchase of a Revolabs Wireless Microphone System! This system utilizes 1.9 GHz DECT technology, and high band-width audio from multiple wireless microphones, enabling clear, reliable, un-tethered communications in recording, audio/video conferencing, speech recognition, VOIP communications, sound re-enforcement as well as many other environments requiring clear audio capture.



The Revolabs HD™ Single and Dual Channel Wireless Microphone Systems have high definition audio, 50 Hz to 20 kHz, which allows the systems to pick up the entire human voice spectrum. The HD Single and Dual Channel Systems are a unique marriage of innovative technology and ergonomic design, employing Multi-Carrier Time Division Multiple Access and Time Division Duplex (MC/TDMA/TDD) radio transmissions both to and from the microphone.

This technology allows the microphones to co-exist with other wireless products such as wireless LANs (802.11b&g), and includes digital encryption technology to ensure secure communications.

System Components

Depending on which system you've purchased, your Revolabs HD™ System contains the following:

- Mountable Single or Dual Channel Base Station
- Single or Dual Channel Microphone Charger Base
- HD Wireless Microphones, purchased and boxed separately

The Base Station houses the processor and one end of the wireless connection. It features one set of PCB diversity antennae and offers individual line-level or mic-level audio in/out for each microphone channel.

This allows for external audio processing such as:

- Mixing

- Acoustic echo cancellation (AEC)
- Feedback elimination
- Level control
- Equalization
- Noise cancellation

The system is designed to optimize audio capture/reproduction by providing:

- Consistent audio input from all participants
- Minimum room noise
- Mute control
- Wireless encryption
- Automatic channel selection
- Full duplex audio

The Charger Base charges the HD Wireless Microphones and stores them when not in use.

Installing the Revolabs HD™ Base Station

The Revolabs HD™ Channel Base Station, shown below in front and rear panel views, manages wireless audio signal processing, pairing, and muting between the Revolabs microphones and the Base Station.

Front View



Rear View

2

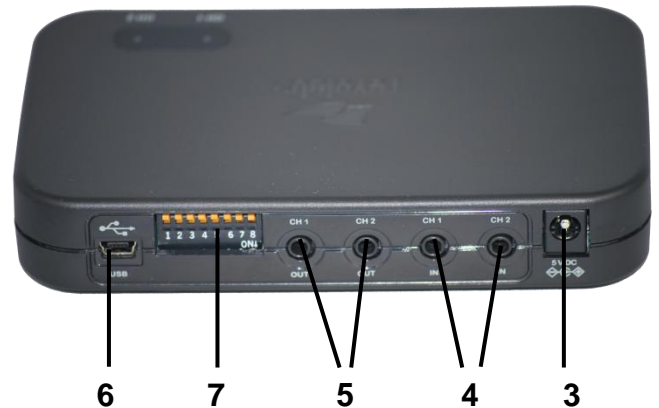

6

7

5

4

3

Controls and Connections:

1. Channel LED indicators: Displays microphone mute and pairing states
2. Pairing Push Buttons: For pairing microphones to Base Station
3. Power In Receptacle (100-240 VAC)
4. 3.5mm Balanced Input Connectors
5. 3.5mm Balanced Output Connectors
6. Mini-USB Serial Interface
7. Configuration DIP Switches (see Section *Using the Rear Panel Configuration DIP switches*)

To Install the Base Station:

1. Plug the power cord into an appropriate outlet
2. Connect the necessary outputs and inputs

Revolabs HD™ Base Station Audio Connections

There are (2) 3.5mm balanced inputs and (2) 3.5mm balanced outputs on the back panel of the unit providing access to each channel's audio signal.

The three terminals correspond to:

Tip = Positive +
Ring = Negative –
Sleeve = Shielded Ground

There are one or two output channels representing a separate channel for each microphone. The microphone output connectors need to be attached to the input connectors of an audio mixer.

The Base Station input connectors (also 0 dBu) may then be attached to mixer channel outputs. Because the system is full-duplex, the input connections provide the ability to hear program audio using a 2.5mm earpiece attached to the microphone (supplied with the wearable microphone). Depending on the application, it is possible to feed a single audio feed back to each earpiece. This would allow for translation, personal hearing assistance or other services to be incorporated into an application.

NOTE: The USB port may exhibit static sensitivity. If the Base Station audio shuts down after handling, please power cycle the Base Station

Note: *The HD Single/Dual System is not compatible with any other Revolabs system and therefore cannot be installed in the same room. The HD and Solo Wireless Microphones and Charger Bases are not interchangeable. No more than one HD Single/Dual system can be used in a single room. Please contact support@revolabs.com for design recommendations.*

Configuring the Revolabs HD™ Base Station

Each Revolabs HD™ Base Station must be configured properly prior to use. Accurate configuration is dependent on several variables such as:

- **Is Line Level or Mic Level signal required?**
Refer to setting Dip Switch 3 below.
- **How many HD™ Dual/Single Systems are being used together in close proximity?**
If you have more than one Revolabs Wireless Microphone System, refer to setting Dip Switch 7&8 below. Note: *It is recommended that the lowest functioning Transmit Power be used for each system.*
- **How large is the room?**
Refer to setting Dip Switch 7&8 below. Note: *It is recommended that the lowest functioning Transmit Power be used for each system.*

Using the Rear Panel Configuration DIP Switches

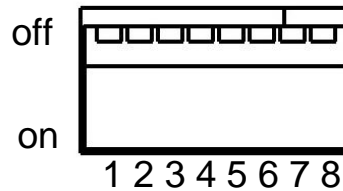

DIP Switch	Feature	Off (Default)		On	
1	Output Mixing	Individual Outputs		Mixed Output	
2	Low Pass Filter	No LPF		LPF	
3	Audio Output Level	Line Level		Mic Level	
4	Mute Mode	Individual Mutes		No Mutes	
		Flat	High boost	Bass Boost	Dynamic
5	Microphone EQ	Off	On	Off	On
6		Off	Off	On	On
		65'	50'	30'	15'
7	Transmit Power	Off	On	Off	On
8		Off	Off	On	On

Configuration Settings

DIP Switch 1- Output Mixing:

When DIP Switch 1 is OFF(default), each HD microphone has its own 3.5mm balanced audio output on the Base Station. When DIP Switch 1 is switched on, the audio outputs of the two HD microphones are mixed together and sent to both outputs.

DIP Switch 2 - Low Pass Filter:

When DIP switch 2 is OFF(default) the microphone provides a 50 Hz-20 kHz audio bandwidth. When DIP switch 3 is ON, a LPF is activated taking the audio bandwidth to 50 Hz-15 kHz.

DIP Switch 3 – Audio Output Level:

When DIP switch 3 is OFF(default) the microphone outputs provide a line level signal ~0 dBu. When DIP switch 3 is ON, the microphone outputs provide a mic level signal ~-40 dBu.

DIP Switch 4 - Mute Mode:

When DIP switch 4 is OFF(default) each microphone has its own individual muting capabilities. When DIP switch 4 is ON, the microphone mute buttons are deactivated resulting in the mics always being active and un-muted when not in the Charger Base.

DIP Switch 5&6 – Microphone EQ:

There are four EQ options for the microphone outputs of the Base Station. One of these options can be activated for both microphones.

DIP Switch 7&8 - Transmit Power:

The transmit power of the Base Station can be adjusted to help reduce the operational radius of a Revolabs HD™ System in order to prevent interference from other Revolabs products, or from other devices operating in the same frequency.

Note: *It is recommended that the lowest functioning Transmit Power be used for each system.*

Revolabs HD Microphones and HD Microphone Adapters

Use any of five microphones with your Revolabs HD™ System:

- Revolabs HD Wearable Wireless Microphone
- Revolabs HD Omni-directional Tabletop Wireless Boundary Microphone
- Revolabs HD Uni-directional Tabletop Wireless Boundary Microphone
- Revolabs HD Universal Wireless Adapter for Handheld Microphones
- Revolabs HD Wireless Adapter for Countryman Microphones

Using the HD Wearable Wireless Microphones

The Revolabs HD Wearable Microphones, shown in the following figure, are paired to the Base Station and can be worn on the user's shirt pocket, lapel or on a lanyard. They provide high quality full duplex audio between each user and the conferencing or audio system.

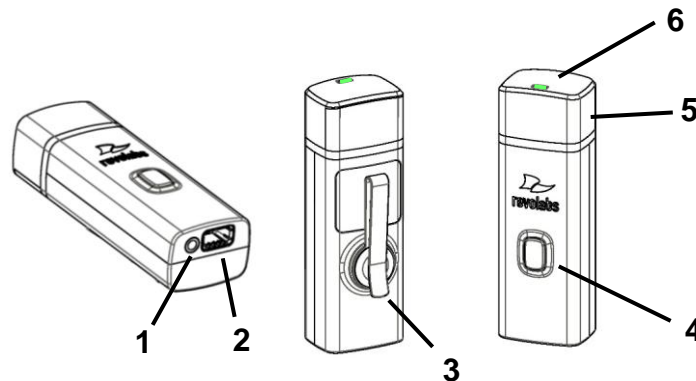

1. Earpiece jack — accepts the 2.5mm plug for the earpiece.
2. Charging port — docks to Revolabs HD Charger Bases.
3. Pocket clip — also used to attach microphone to a lapel, blouse or lanyard.
4. Mute Button — press to mute, un-mute and pair microphone.
5. Acoustic Cover — protects delicate microphone element (non-removable).
6. LED display — visual status for mute, un-mute, and pairing.

Note: *Microphones in new systems must be paired to the Base Station with each microphone assigned to a unique channel on the base unit. See pairing instructions below.*

Revolabs HD Wearable Microphones turn on and mute automatically when removed from Charger Base, to reduce noise while being attached.

To use the HD Wearable Microphone:

1. Remove the microphone from the Charger Base.
2. Attach the microphone to clothing or to a lanyard, position microphone just above the sternum or breastbone, within 6 - 12 inches (15 – 30cm) from the mouth is recommended. Make sure microphone is attached securely with the microphone LED indicator pointed up toward mouth.

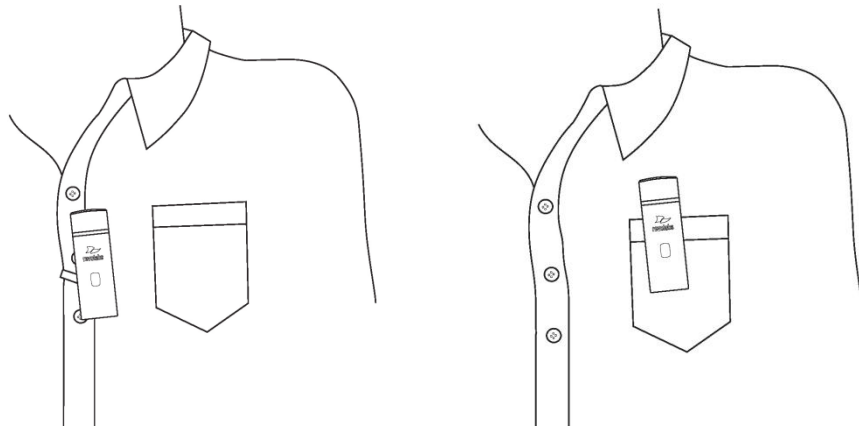

3. With the microphone in the wearing position, un-mute the microphone by pressing and releasing the Mute button (confirm by a flashing GREEN LED). If the volume is too low, move the microphone closer to the mouth.
4. To turn microphones off, return the microphone unit to the Charger Base or press and hold the Mute button for ~10 seconds until the LED turns solid RED then release button.

If the microphones are moved out of range of the Base Station (~65 feet or 20 meters) the connection will be dropped (LED flashes all red, green, yellow) and the microphone will mute.

After 15 seconds the microphone will beep 5 times, and will continue beeping every 30 seconds to remind the user to return the microphone to the conference room. If the microphone is moved back into range within 15 minutes the connection will automatically be re-established to its original state, and the beeping will cease. If not, the microphone will turn off.

Adjusting the Volume on the Wearable Microphone Earpiece

To change the volume on the Wearable microphone earpiece, use the dial on the earpiece wire.

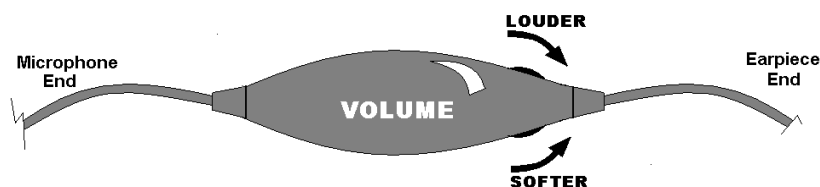

Turning the dial towards the earpiece, as shown in the figure, will increase the volume, and turning the dial towards the microphone will decrease the volume. Use the attached clothing clip to secure the earpiece wire.

Using the HD Omni-Directional Tabletop Wireless Boundary Microphones

The HD Omni-directional Tabletop Wireless Boundary Microphones enable multiple conference attendees to use a single microphone.

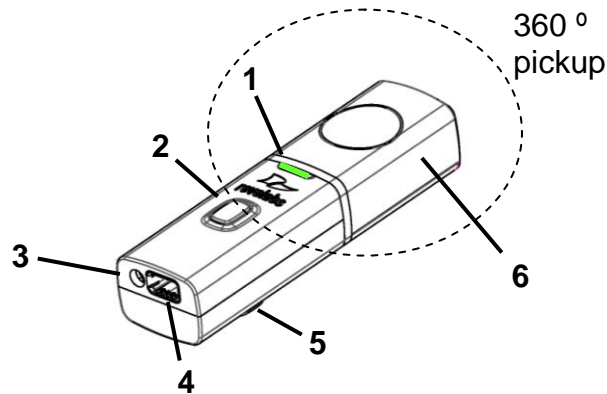

1. LED display — visual status for mute, un-mute, and pairing.
2. Mute button — press to mute, un-mute and pair microphone.
3. Audio jack — accepts a 2.5mm plug.
4. Charging port — docks to Revolabs HD Charger Bases.
5. Rubber feet — non-slip, vibration absorbing pads.
6. Acoustic Cover — protects delicate microphone element (non-removable).

To use the HD Omni Tabletop Microphone:

1. Remove the microphone from the Charger Base to turn on and automatically mute the mic. (indicated by a flashing RED LED)
2. Omni Tabletop microphones can be centered on the table within 2 to 5 feet (0.6 to 1.5m) away from people speaking and do not need to be pointing any particular direction because they pick up sound from all directions. It is always better to be as close to the person speaking as possible, but avoid placing the microphone where it might be blocked by equipment or paperwork. Avoid placing microphones too close to an audio or video conference speaker to avoid echoes. Make sure that the microphone is always placed lying on its rubber feet atop a flat surface.

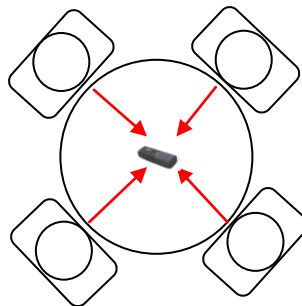

3. With the microphone in position on the table, un-mute the microphone by pressing and releasing the Mute button (confirm by a flashing GREEN LED).
4. To turn microphone off, return the microphone unit to the Charger Base or press and hold the Mute button for ~10 seconds until the LED turns solid RED and release button.

If the microphones are placed too far from the Base Station (~65 feet or 20 meters) the connection will be dropped (LED flashes all colors) and the microphone will mute. After 15 seconds the microphone will beep 5 times, and will continue beeping every 30 seconds to indicating it's out of range.

Move the microphone closer to the Base Station and the connection will automatically be re-established to its original state, and the beeping will cease. If not, the microphone will continue beeping until it turns off in about 15 minutes.

Using the HD Directional Tabletop Wireless Boundary Microphones

The HD Tabletop Wireless Microphone, shown below, is designed to provide optimum coverage when placed on a conference room table in front of one or two people.

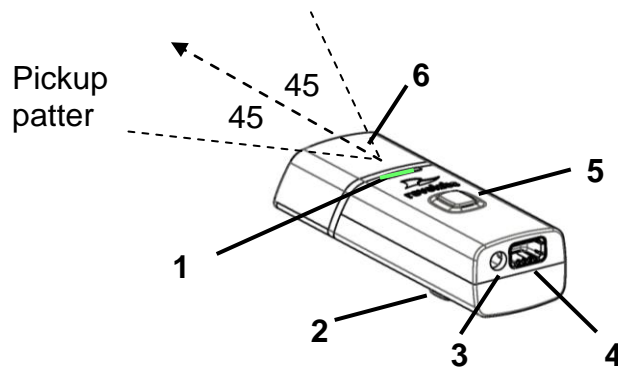

1. LED display — visual status for mute, un-mute, and pairing.
2. Rubber feet — non-slip, vibration absorbing pads.
3. Audio jack — accepts a 2.5mm plug.
4. Charging port — docks to Revolabs HD Charger Bases.
5. Mute button — press to mute, un-mute and pair microphone.
6. Acoustic Cover — protects microphone element (non-removable).

To use the HD Directional Tabletop Microphone:

1. Remove the microphone from the Charger Base to turn on and automatically mute the mic. (indicated by a flashing RED LED)
2. Directional Tabletop microphones should be located on the table with the acoustic cover pointed toward the users, trying to keep the microphone 2 to 5 feet (0.6 to 1.5m) from the target person or two. The pick-up pattern for this directional microphone is $\sim\pm 45^\circ$ to either side of directly in front of the microphone. It is always better to be as close to the person speaking as possible, but avoid placing the microphone where it might be blocked by equipment or paperwork. Avoid placing microphones too close to an audio or video conference speaker to avoid echoes. Make sure that the microphone is always placed lying on its rubber feet atop a flat surface. Refer to diagram below:

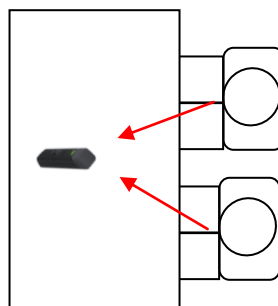

3. With the microphone in position, un-mute the microphone by pressing and releasing the Mute button (confirm by a flashing GREEN LED).
4. To turn microphone off, return the microphone unit to the Charger Base or press and hold the Mute button for ~10 seconds until the LED turns solid RED and release button.

If the microphones are placed too far from the Base Station (~65 feet or 20 meters) the connection will be dropped (LED flashes all colors) and the microphone will mute. After 15 seconds the microphone will beep 5 times, and will continue beeping every 30 seconds to indicating it's out of range.

Move the microphone closer to the Base Station and the connection will automatically be re-established to its original state, and the beeping will cease. If not, the microphone will continue beeping until it turns off in about 15 minutes.

Using the HD XLR Microphone Wireless Adapter

The HD Wireless XLR Adapter for Handheld Microphone, shown in the following figure, connects to a handheld dynamic microphone for wireless freedom during open mic meetings, Q&A sessions, classrooms, etc.

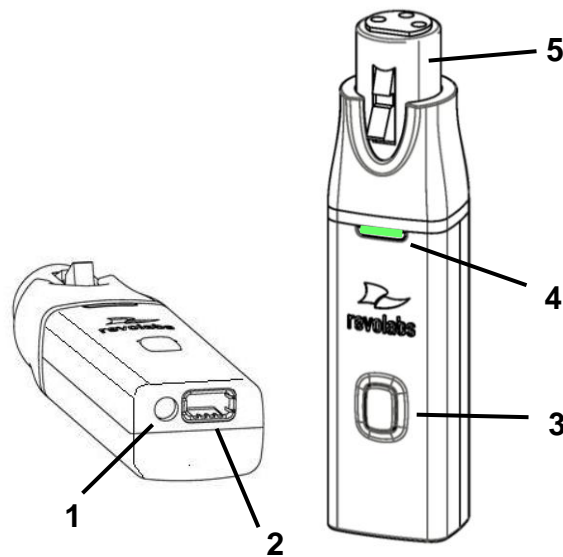

1. Audio Out port — accepts the 2.5mm plug for the earpiece.
2. Charging Port — docks to all Revolabs HD Charger Bases.
3. Mute button — press to mute, un-mute and pair microphone.
4. LED display — visual status for mute, un-mute, and pairing.
5. XLR Female connector — balanced audio for dynamic microphones.

To use the HD Universal Wireless Adapter:

1. Remove the Microphone Adapter from the Charger Base.

The adapter turns on and mutes automatically when removed from Charger Base (flashing RED LED). The XLR Microphone Adapter is attached to a standard dynamic microphone to convert it from a wired microphone to a wireless microphone (see following figure).

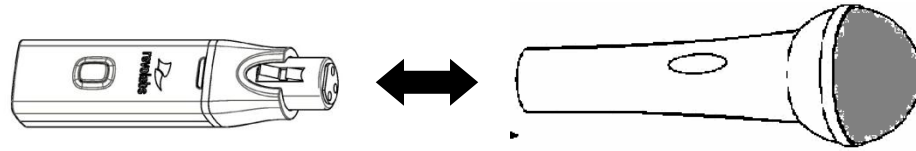

Note: The Adapter does not provide phantom power or bias current so it cannot be used with condenser or electret microphones.

2. With the microphone attached, un-mute the Adapter by pressing and releasing the Mute button (confirm by a flashing GREEN LED).

Note: If the microphone has an on-board mute switch, this switch must also be un-muted prior to use.

3. To turn the Adapter off, return the microphone unit to the Charger Base or press and hold the Mute button for ~10 seconds until the LED turns solid RED then release button.

Important: Always remove the microphone from the Adapter by pressing the latch switch and separating the parts before returning the Adapter to the Charger Base.

If the Adapter is moved too far from the Base Station (~65 feet or 20 meters) the connection will be dropped (LED flashes all colors) and the audio will mute. After 15 seconds the microphone will beep 5 times, and will continue beeping every 30 seconds to indicate that it is out of range.

Move the XLR Adapter closer to the Base Station and the connection will automatically be re-established to its original state, and the beeping will cease. If not, the XLR Adapter will continue beeping until it turns off in about 15 minutes.

Using the HD Wireless Adapter for Countryman Microphone

The HD Wireless Adapter for Countryman Microphones, shown in the following figure, is connects to a Countryman microphones for wireless freedom for broadcasting applications with no bulky equipment, such as a belt pack or batteries.

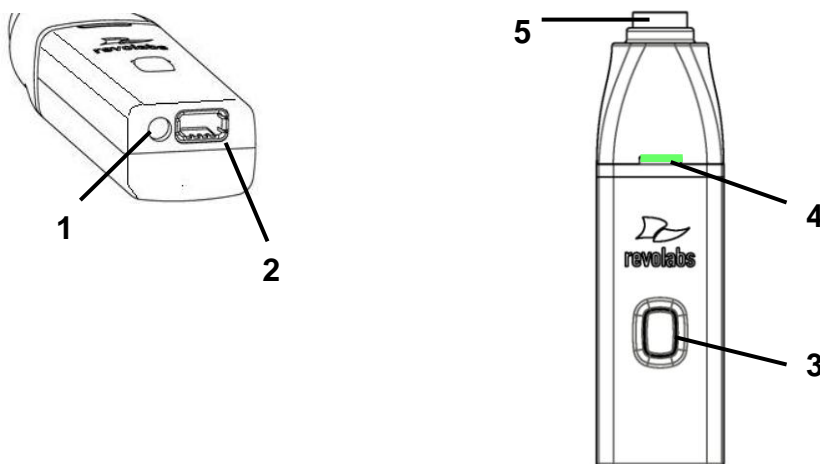

1. Audio Out port — accepts the 2.5mm plug for the earpiece.
2. Charging Port — docks to all Revolabs HD Charger Bases.
3. Mute button — press to mute, un-mute and pair microphone.
4. LED display — visual status for mute, un-mute, and pairing.
5. TA4F connector — connects to Countryman microphone cable.

To use the HD Wireless Adapter for Countryman Microphone:

4. Remove the Microphone Adapter from the Charger Base.

The adapter turns on and mutes automatically when removed from Charger Base (flashing RED LED). The Microphone Adapter is attached to a Countryman Microphone with the specific cable designed for Revolabs. The HD Wireless Adapter for Countryman microphone supplies the necessary phantom power specifically for the Countryman microphone.

5. To turn the Adapter off, return the microphone unit to the Charger Base or press and hold the Mute button for ~10 seconds until the LED turns solid RED then release button.

Important: Always remove the microphone from the Adapter and separate the parts before returning the Adapter to the Charger Base.

If the Adapter is moved too far from the Base Station (~65 feet or 20 meters) the connection will be dropped (LED flashes all colors) and the audio will mute. After 15 seconds the microphone will beep 5 times, and will continue beeping every 30 seconds to indicate that it is out of range.

Move the Countryman Adapter closer to the Base Station and the connection will automatically be re-established to its original state, and the beeping will cease. If not, the Countryman Adapter will continue beeping until it turns off in about 15 minutes.

Pairing Wireless Microphones to Base Station

Pairing creates a link between the HD Wireless Microphone and the Base Station, with a unique electronic serial number. When the microphone and Base Station have been previously paired, the mic will automatically try to connect to the same Base Station whenever it is lifted from the Charger Base.

Note: *Microphones in new systems must be paired to the Base Station with each microphone assigned to a unique channel on the Base Station.*

Remember, microphones are always muted (flashing RED LED) when they are removed from the Charger Base and the Mute button needs to be pressed to make it “live” (flashing GREEN LED).

A microphone that is not paired will be indicated by a cycling RED-GREEN LED pattern. A Base Station channel that is not paired to a microphone will not show any activity on the channel LED (make sure unit is first powered on by observing GREEN backlit front panel display).

When channels are paired, both microphone and channel LEDs will flash RED as microphones are removed from the Charger Base and flash GREEN when un-muted. Remember that only one microphone can be paired to any single Base Station channel.

To pair an individual microphone to the Base Station:

1. Turn the microphone OFF (no LED activity). If the microphone is ON, press and hold the Mute button for 10 seconds until the LED turns solid RED then release the button to turn the unit off. (do not release the button when you hear two beeps).
2. Place the microphone unit into pairing mode by holding the Mute button down for seven seconds. The LED will turn solid RED. Release the Mute button. The microphone is now in pairing mode.
3. Within one minute, push and hold the button for the desired channel on the Base Station for seven seconds until the LED turns solid red then release. The LED for that channel will be solid red until pairing starts, as indicated by a quick GREEN flash, then switching to flashing RED on both the microphone and the Base Station (muted audio). Pairing is now complete.

Revolabs HD™ Single or Dual Charger Base

When microphones are not in use, they should be properly inserted into the Revolabs HD Charger Base. It is important to ensure that all system microphones are inserted fully in the base so that charging will occur. Features of the base are shown in the following figure.



1. LED indicator — power status indicator
2. Charger Bays — charges up to 2 Microphones
3. Power Cord Receptacle — power supply input, 9-24VDC (on rear)

Power Module

The Charger Base requires 5VDC power, provided by the AC Adapter. Plug the supplied AC adapter into an appropriate power outlet 110-240 AC, 50-60Hz. The power LED on the Charger Base will illuminate.

Charging the Microphone Batteries

First-time use — Before using the wireless microphone the first time, charge the batteries in the microphones for eight hours (or overnight) in the Charger Base.

Recharging — When the YELLOW LED starts to flash intermittently on the microphone the battery has 30 minutes of charge remaining. Over time (years), batteries gradually wear down and will result in shorter run times. This is normal. Always return microphones to the Charger Base when not in use.

Important: *The Lithium Polymer rechargeable batteries that power the microphones are not user serviceable. Please contact Revolabs (www.revolabs.com) or your AV service provider for replacement instructions and to assure the proper disposal method is used. **Warning: Never dispose of batteries in a fire because they may explode.***

Either a solid RED LED (charging) or solid GREEN LED (100% charged) will appear to confirm that the microphone is inserted properly in the Charger Base. The microphones are not transmitting audio to the HD Base Station while in the Charger Base. In normal use, batteries should fully charge in about 2 hours, but will “quick-charge” to 80% capacity in approximately 1 hour and 20 minutes. Fully charged microphones left in the Charger Base remain solid GREEN.

Updating the Revolabs HD™ Firmware

Revolabs HD™ Systems are field upgradable for the firmware portion of the Base Station and microphones. The firmware must be sent to the Base station using the Revolabs HD Single/Dual firmware loader. The software can be downloaded at www.revolabs.com/downloads.

Updating the HD Single/Dual Channel Base Station and HD Microphones

1. Connect to the Base Station using the mini-USB cable.
2. Pair both mics to the Base Station and make sure they are out of the Charger Base.
3. Start the Revolabs HD Firmware Loader software
4. Choose the desired firmware version from the location it was saved during download.
5. Choose whether you would like to update the Base Station, Mics, or Both.
6. Select OK. The Revolabs HD Firmware Loader will notify you when complete.

The HD Microphone firmware updates wirelessly during the firmware process as long as the microphones are out of the Charger Base, paired to the Base Station, and communicating with the Base Station.

Revolabs HD™ Indicator LEDs

The following tables show activities associated with the various states shown by the LEDs:

Equipment Use	Microphone LED	Base Station Channel LEDs	Meaning
Microphone in Charger Base	Solid RED	OFF	Charging in Progress
	Solid GREEN	OFF	Charging Complete
Microphone not in Charger Base	OFF	OFF	Microphone powered OFF or battery discharged
	Two RED flashes every 1.5 seconds	Two RED flashes every 1.5 seconds	Microphone paired and muted
	One GREEN flash every 1.5 seconds	GREEN flash every 1.5 seconds	Microphone paired and "live"
	Solid RED	Solid RED	Pairing mode or confirmation of powering-down.
	Alternating slow GREEN and RED	Alternating slow GREEN and RED	Microphone or channel not paired
	YELLOW flash alternating with GREEN flash	GREEN Flashing	Microphone low battery (mic live)
	YELLOW flash alternating with two RED flashes	RED Flashing	Microphone low battery (mic muted)
	Alternating RED, YELLOW, GREEN	OFF	Searching for a connection, or out of radio range. The Microphone will try to re-establish the link for about 15 minutes, and then turn off automatically.
	Rapid RED flashes continuing for more than a few seconds	OFF	Radio congestion – it is not possible to make a radio connection because there are already too many nearby users, or there is heavy radio interference. Possibilities include some types of digital wireless devices or other Revolabs installations.
	Groups of five rapid RED flashes	OFF	Unit is faulty. Contact your AV service provider for advice.

Warranty

Revolabs, Inc. warrants this product to be free of manufacturing defects. Repair or replacement of any defective part or unit (at the discretion of the Seller) will be free of charge for the period of one year.

Any attempt by the user to alter the equipment, or equipment damaged by negligence, accident, or Acts of God voids this warranty.

The Seller shall not be liable for any consequential damage resulting from the malfunction of this product. Should the user experience unsatisfactory performance from this equipment, contact the Seller to obtain instructions for return, or replacement, as deemed necessary.

This warranty is not transferable by the original end user.

Revolabs, Inc.
63 Great Road
Maynard, MA 01754
www.revolabs.com
800.326.1200

Specifications

Dimensions, (L, W, H) and Weight:

Single/Dual Base Station	5.19" (13.18 cm) x 3.25" (8.25 cm) x 1.0" (2.54 cm), 0.325 lbs (0.147 kg)
Single/Dual Charger Base	4.6" (11.75 cm) x 3.125" (7.9 cm) x 1.0" (2.54 cm), 0.325 lbs (0.147 kg)
Wireless Microphones	Wearable: 0.9" (2.3 cm) x 0.8" (2.0 cm) x 2.6" (6.6 cm), 0.05 lb (0.02 kg)
	TableTop: 1.5" (3.8 cm) x 0.8" (2.0 cm) x 3.3" (8.4 cm), 0.05 lb (0.02 kg)
	XLR Adapter: 0.9" (2.3 cm) x 0.8" (2.0 cm) x 4.0" (10.2 cm), 0.05 lb (0.02 kg)
	Countryman Adapter: 1.5" (3.8 cm) x 0.8" (2.0 cm) x 3.3" (8.4 cm), 0.05 lb (0.02 kg)
Shipping Weight	2.0 lbs (5.45 kg)

Radio Frequency:

02-HDSGL (and other 02-HD* products)	1.92 to 1.93 GHz (UPCS North America)
04-HDSGLEU (and other 04-HD* products)	1.88 to 1.90 GHz (DECT EU)

Connectors:

Base Station Audio	3.5mm Balanced (2 In & 2 Out)
Firmware Port	Mini-USB
Charger Base	DC power input port, Proprietary 4 pin microphone charge jacks
Microphone	Proprietary 4 pin charge plugs, 2.5mm mono earplug port (16 ohm)

Power Requirements:

Base Station	5V DC, 1 Amp (switching power supply varies by country)
Charger Base	5V DC, 2 Amps (switching power supply varies by country)

Range: 65' (20 meters) approx. (no obstructions)

Battery: Lithium Polymer, Up to 8 hours approx. talk time

Charge Time: 2 hours approx.

Audio Bandwidth: 50-20,000 Hz or 50-12,000 Hz (selectable)

Security: 128-bit DSAA (DECT Standard Authentication Algorithm) authentication, 64 bit DECT Standard Cipher

Included Accessories: 1 Earpiece with inline volume control and 1 Lanyard per Wearable Microphone

Environmental Requirements:

Temperature	40° to 105° F (5° to 40° C) operating
Humidity	20% to 85%

Index

- Adjusting the Volume, 8
- Base Station, 4
 - Back Panel, 4
 - Front Panel, 4
- Channel LED indicators, 5
- Channels, 5
- Charger Bays**, 13
- Charging the Batteries, 13
 - First-time use, 13
 - Recharging, 13
- Connections, 5
- Earpiece, 5
- Full-Duplex, 5
- Indicator LEDs, 15
- Input Connectors, 5
- LED indicator**, 13
- MC/TDMA/TDD, 3
- Microphone
 - Charging port, 7
 - Earpiece Jack, 7
 - LED Display, 7
 - Mute Button, 7
 - Pocket Clip, 7
- Microphones, 7
- Pairing, 12
- Power Cord Receptacle**, 13
- Power In Receptacle, 5
- Power Module, 13
- Safety Information, 1
- Specifications, 17
- System Components, 3
 - Base Station, 3
 - Diversity Antennas, 3
 - Earpieces, 3
 - Microphone Charger Base, 3
 - Microphone Lanyards, 3
- Time Division Duplex, 3
- Time Division Multiple Access, 3
- Warranty, 16
- Wireless Boundary Microphone, 9, 10
- XLR Microphone Wireless Adapter, 11

Note: *Microphones must be fully charged and paired to the Base Station prior to first use.*

Revolabs HD™ Single & Dual Manual
01-HDSGLMAN-PAP-11
March 2010 (Rev 1.6)

Free Manuals Download Website

<http://myh66.com>

<http://usermanuals.us>

<http://www.somanuals.com>

<http://www.4manuals.cc>

<http://www.manual-lib.com>

<http://www.404manual.com>

<http://www.luxmanual.com>

<http://aubethermostatmanual.com>

Golf course search by state

<http://golfingnear.com>

Email search by domain

<http://emailbydomain.com>

Auto manuals search

<http://auto.somanuals.com>

TV manuals search

<http://tv.somanuals.com>