

OPERATING AND INSTALLATION INSTRUCTIONS

Models 136-1826

MODEL

SERIAL NUMBER

INSTALLATION DATE

START UP DATE



FOR YOUR SAFETY

Do not store or use gasoline or other flammable vapors or liquids or other combustible materials in the vicinity of this or any other appliance. To do so may result in an explosion or fire.

WARNING

Improper installation, adjustment, alteration, service or maintenance can cause property damage, personal injury or loss of life. Refer to the user's information manual provided with this heater. Installation and service must be performed by a qualified installer, service agency or the gas supplier.

FOR YOUR SAFETY

WHAT TO DO IF YOU SMELL GAS

- * Do not try to light any appliance.
- * Do not touch any electrical switch; do not use any phone in your building.
- * Immediately call your gas supplier from a neighbor's phone. Follow the gas supplier's instructions.
- * If you cannot reach your gas supplier, call the fire department.

IMPORTANT WARNING

THE HEATER MUST BE INSTALLED IN ACCORDANCE WITH THE INSTRUCTIONS IN THIS MANUAL. WARRANTY WILL NOT APPLY TO UNITS NOT INSTALLED, OPERATED OR MAINTAINED ACCORDING TO THESE INSTRUCTIONS. THE INSTALLATION MUST CONFORM TO THE AUTHORITIES HAVING JURISDICTION AND/OR WITH THE LATEST EDITIONS OF THE **NATIONAL FUEL GAS CODE ANSI-Z223.1**, THE **NATIONAL ELECTRIC CODE ANSI/NFPA 70**.



Rheem Commercial Water Heater Products
Ruud Commercial Water Heater Products
One Bell Road • Montgomery, AL 36117
(205) 260-1500

Part No. 240454

INDEX

3	COPPER SANIMASTER AND TYPHOON HOT WATER HEATERS
4	Specification Data
7	INTRODUCTION
	INSTALLATION GUIDELINES
8	Base Requirements
9	Combustible Construction Clearances
10	Combustion Air Supply
	Outdoor Venting
12	Indoor Venting
16	Power Venting
	Outdoor Heaters
	Vent Damper Installation
18	Piping (Gas and Water)
20	Cold Water Supply
21	Hot Water Supply Heater
22	Piping Diagram - 1 Heater 1 Tank Thermostat Supplied
23	Piping Diagram - 1 Heater 2 Tank
24	Piping Diagram - 1 Heater 3 Tank
25	Piping Diagram - 1 Heater 4 Tank
26	Piping Diagram - 2 Heater 1 Tank Uses Special Thermostat & Well
27	Description of Controls in General
	Operating Controls
28	Tankstat Temperature Control
29	Electrical
29	Start-Up
30	General Safety Precautions
31	Lighting Instructions
33	Inspection and Maintenance Procedures
	Burner Inspection
34	Venting System Inspection
	Circulator (Water Pump) Inspection
	Service Assistance
35	Trouble Shooting
39	Wiring Diagram
44	Replacement Parts List

COPPER SANIMASTER AND TYPHOON HOT WATER HEATERS

Series GB

for circulating tank systems

136 through 1826 MBTUH

Model Applications

Hot water Supply Heaters are designed to provide hot water service to a variety of applications when used in conjunction with an appropriately sized storage tank. Models are available for indoor or outdoor installations, and controls and pump are factory tested and mounted.*

Construction Features

1. All copper high efficiency heat exchanger.
2. Factory mounted pump suited for a wide variety of water conditions.*
3. Flow Switch included on all models.
4. All models feature an energy saving pump control.
5. Glass-lined cast iron headers to handle the most aggressive water conditions.+
6. All units are tested and certified to ANSI Z21.10.3 and carry National Board Stamps HLW.
7. Factory installed pressure relief valve.
8. Temperature pressure gauge and tankstat are included.
9. All inputs over a 400,000 BTU feature intermittent pilot ignition.
10. Models available for Natural or LP Gas.

* Pump shipped separate in carton on Models 136 through 399.

+ Model 136 features Bronze Headers.

SPECIFICATION DATA

MODEL		STYLE		MBH Natural Gas			
				Sanimaster (Indoor)		Typhoon (Outdoor)	
		In-Door	Out-Door	Input	Output	Input	Output
136		•	•	136.0	112.0	136.0	112.0
181		•	•	181.0	148.0	181.0	148.0
264		•	•	264.0	216.0	264.0	216.0
331		•	•	334.0	274.0	334.0	274.0
399		•	•	399.0	327.0	399.0	327.0
512		•	•	511.5	419.4	511.5	419.4
627		•	•	627.0	514.0	627.0	514.0
726		•	•	726.0	595.0	726.0	595.0
825		•	•	825.0	676.5	825.0	676.5
926			•			926.0	759.0
962		•		961.7	788.6		
1083			•			1083.0	888.0
1125		•		1124.7	922.0		
1178			•			1178.0	966.0
1223		•		1222.5	1002.4		
1287			•			1287.0	1055.0
1337		•		1336.6	1096.0		
1413			•			1413.0	1158.5
1467		•		1467.0	1203.0		
1570			•			1570.0	1287.0
1630		•		1630.0	1336.6		
1758			•			1758.0	1441.5
1826		•		1825.6	1497.0		

ELECTRICAL RATINGS	
Model Size	With Pump
136-264	3.4 amps @ 120V (1/8 hp pump)
331-399	3.6 amps @ 120V (1/6 hp pump)
512-1826	7.9 amps @ 120V (1/2 hp pump)

MBTUH PROPANE GAS†	
Model Size	Multiplier
136-399	Same as natural gas
512-825	.94
926-1826	.92 Indoor .955 Outdoor (Input) .92 Outdoor (Output)

† Multiplier x Nat. MBTUH = Pro. MBTUH

Rated inputs are suitable for up to 2000 feet elevation. For elevations above 2000 feet, reduce input 4% for each 1000 feet above sea level. These heaters are tested and certified to ANSI Standard Z 21.10.3

RECOVERY RATES Rheem Hot Water Heaters

		Indoor Models													
Model Number	Input MBTUH	Temperature Rise in Degrees, F													
		10	20	30	40	50	60	70	80	90	100	110	120	130	140
		Gallons per Hour													
136	136	1352	676	451	338	270	225	193	169	150	135	123	113	104	97
181	181	1799	900	600	450	360	300	257	225	200	180	164	150	138	129
264	264	2624	1312	875	656	525	437	375	328	292	262	239	219	202	187
331	334	3320	1660	1107	830	664	553	474	415	369	332	302	277	255	237
399	399	3966	1983	1322	991	793	661	567	496	441	397	361	330	305	283
512	511.5	5084	2542	1695	1271	1017	847	726	636	565	508	462	424	391	363
627	627	6232	3116	2077	1558	1246	1039	890	779	692	623	567	519	479	445
726	726	7216	3608	2405	1804	1443	1203	1031	902	802	722	656	601	555	515
825	825	8200	4100	2733	2050	1640	1367	1171	1025	911	820	745	683	631	586
962	961.7	9559	4779	3186	2390	1912	1593	1366	1195	1062	956	869	797	735	683
1125	1124.7	11179	5589	3726	2795	2236	1863	1597	1397	1242	1118	1016	932	860	798
1223	1222.5	12151	6075	4050	3038	2430	2025	1736	1519	1350	1215	1105	1013	935	868
1337	1336.6	13285	6642	4428	3321	2657	2214	1898	1661	1476	1328	1208	1107	1022	949
1467	1467	14581	7291	4860	3645	2916	2430	2083	1823	1620	1458	1326	1215	1122	1042
1630	1630	16201	8101	5400	4050	3240	2700	2314	2025	1800	1620	1473	1350	1246	1157
1826	1825.6	18145	9073	6048	4536	3629	3024	2592	2268	2016	1815	1650	1512	1396	1296
		Outdoor Models													
136	136	1352	676	451	338	270	225	193	169	150	135	123	113	104	97
181	181	1799	900	600	450	360	300	257	225	200	180	164	150	138	129
264	264	2624	1312	875	656	525	437	375	328	292	262	239	219	202	187
331	334	3320	1660	1107	830	664	553	474	415	369	332	302	277	255	237
399	399	3966	1983	1322	991	793	661	567	496	441	397	361	330	305	283
512	511.5	5084	2542	1695	1271	1017	847	726	636	565	508	462	424	391	363
627	627	6232	3116	2077	1558	1246	1039	890	779	692	623	567	519	479	445
726	726	7216	3608	2405	1804	1443	1203	1031	902	802	722	656	601	555	515
825	825	8200	4100	2733	2050	1640	1367	1171	1025	911	820	745	683	631	586
926	926	9204	4602	3068	2301	1841	1534	1315	1150	1023	920	837	767	708	657
1083	1083	10764	5382	3588	2691	2153	1794	1538	1346	1196	1076	979	897	828	769
1178	1178	11709	5854	3903	2927	2342	1951	1673	1464	1301	1171	1064	976	901	836
1287	1287	12792	6396	4264	3198	2558	2132	1827	1599	1421	1279	1163	1066	984	914
1413	1413	14044	7022	4681	3511	2809	2341	2006	1756	1560	1404	1277	1170	1080	1003
1570	1570	15605	7802	5202	3901	3121	2601	2229	1951	1734	1560	1419	1300	1200	1115
1758	1758	17473	8737	5824	4368	3495	2912	2496	2184	1941	1747	1588	1456	1344	1248

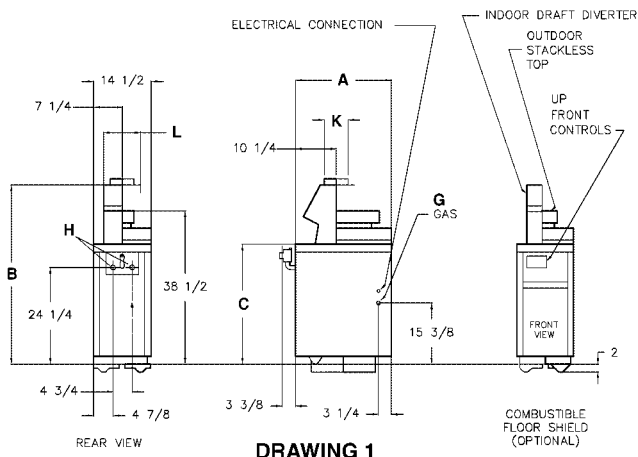

DRAWING 1

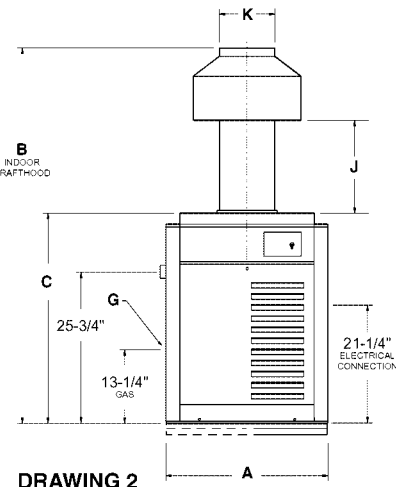
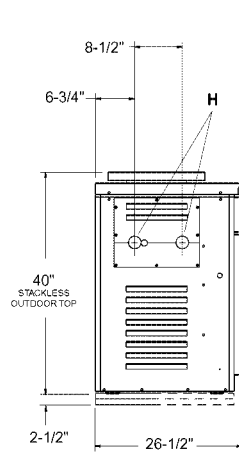

DRAWING 2

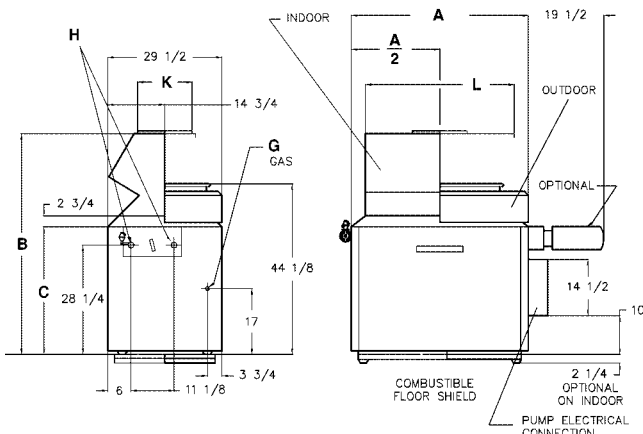

DRAWING 3

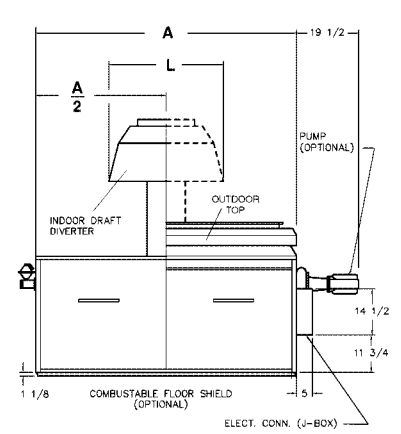
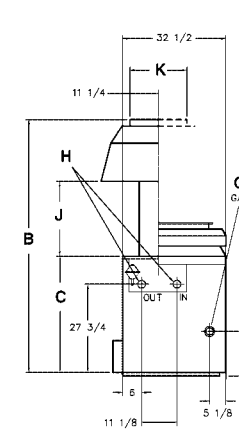

DRAWING 4

Reference to Drawing	MODEL SIZE	Indoor	Outdoor	Width A	Height Overall B	Jacket Height C	Gas Conn. G	Water Connection H	J J	Flue Dia. K	L	SHIPPING WEIGHT LBS (APPROX)	
												Less Pump	W/Pump
1	136	•	•	24-1/8	45	30-1/8	1/2	1-1/4		6	9-1/4	160	210
2	181	•	•	18-1/4	62-5/8	38	3/4	1-1/2	12-1/16	6		182	232
	264	•	•	22-3/8	62-7/8	38	3/4	1-1/2	11-1/8	7		205	255
	331	•	•	25-3/4	63-3/4	38	3/4	1-1/2	10-3/4	8		225	275
	399	•	•	29-1/4	65-3/8	38	3/4	1-1/2	12-1/2	9		244	294
3	512	•	•	32-3/4	57	33	1	2		10	25-3/8	475	530
	627	•	•	37-1/2	57	33	1	2		12	29-1/2	485	540
	726	•	•	41-5/8	57	33	1	2		12	34-1/4	635	690
	825	•	•	45-3/4	57	33	1	2		14	38-1/2	645	700
4	926		•	52-3/8			1	2-1/2				785	840
	962	•		52-3/8	76-1/8	33-1/2	1	2-1/2	23-5/8	14	28	705	760
	1083		•	59-1/4			1	2-1/2				865	920
	1125	•		59-1/4	78-1/8	33-1/2	1	2-1/2	23-5/8	16	32	745	800
	1178		•	63-5/8			1	2-1/2				925	980
	1223	•		63-5/8	78-1/8	33-1/2	1	2-1/2	23-5/8	16	32	805	860
	1287		•	68-5/8			1-1/4	2-1/2				980	1035
	1337	•		68-5/8	80-1/8	33-1/2	1-1/4	2-1/2	23-5/8	18	36	875	930
	1413		•	74-7/8			1-1/4	2-1/2				1080	1130
	1467	•		74-7/8	80-1/8	33-1/2	1-1/4	2-1/2	23-5/8	18	36	945	1000
	1570		•	81-1/8			1-1/4	2-1/2				1130	1190
	1630	•		81-1/8	83-1/8	36-1/2	1-1/4	2-1/2	23-5/8	18	36	985	1040
1758		•	89-3/8			1-1/4	2-1/2				1160	1220	
1826	•			85-1/8	36-1/2	1-1/4	2-1/2	23-5/8	20	40	1035	1090	

A. INTRODUCTION

WE RECOMMEND THAT THIS MANUAL BE REVIEWED THOROUGHLY BEFORE INSTALLING THE WATER HEATER. SHOULD ANY QUESTIONS ARISE, NOT COVERED BY THIS DATA, CONTACT YOUR LOCAL DISTRIBUTOR OR THE SERVICE DEPARTMENT AT THE FACTORY.

MODEL IDENTIFICATION

The model number of the water heater is found on the rating plate. Each model number identifies the application, the construction and the function of the water heater, and provides a positive means of identification for application, installation, operation, service and parts of the unit in a minimum amount of time.

RECEIVING EQUIPMENT

On receiving equipment it is suggested that you

- Review packing slip for the number of packages.
- Inspect for concealed damage immediately.
- Advise carrier, in writing, of shortages or damage.
- Claims are filed by the receiver against the carrier. The carrier, not the shipper, is responsible for any shortage or damage whether visible or concealed.

B. INSTALLATION GUIDELINES

INSTALLATION REGULATIONS

THE INSTALLATION MUST CONFORM WITH THESE INSTRUCTIONS, REQUIREMENTS OR CODES OF AUTHORITIES HAVING JURISDICTION, THE LATEST EDITION OF THE **NATIONAL FUEL GAS CODE, ANSI Z223.1** AND THE **NATIONAL ELECTRICAL CODE**.

ANY ALTERATION OR MODIFICATION TO THE WATER HEATER, ITS COMPONENTS OR ITS INTENDED APPLICATION MAY VOID THE WARRANTY EXTENDED WITH THE PRODUCT BY THE MANUFACTURER.

WARNING: **Improper installation, adjustment, alteration, service or maintenance can damage the water heater, or create a hazard resulting in asphyxiation, explosion or fire.**

WATER FLOW

Low water content heat exchangers require continuous flow for proper operation.

WATER CONDITIONS:

Domestic Hot water heaters are designed for operation with various water conditions. Corrosive water that has high chlorine content or other chemicals require that the tubes in the heat exchanger be cupro-nickel. Provide us with an analysis of water where this potential exists.

BASE REQUIREMENTS

Indoor water heaters must be installed on a level noncombustible surface, except as noted below. **Do not install on carpeting.** Heater sizes 926 to 1758 Typhoon (Outdoor) are supplied with a combustibile flooring base as standard. The following chart lists the part number required for a combustibile base, for water heaters supplied without a combustibile base.

COMBUSTIBLE FLOORBASE

BOILER	PART	BOILER	PART	BOILER	PART	BOILER	PART
136	001749	399	058316	825	056202	1337	059236
181	058313	512	056199	962	059233	1467	059237
264	058314	627	056200	1125	059234	1630	059238
331	058315	726	056201	1223	059235	1826	059239

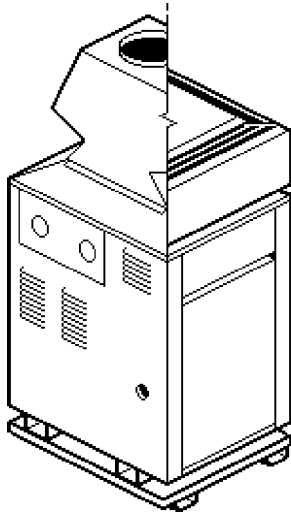

Fig.#8276

HEATER WITH COMBUSTIBLE FLOOR SHIELD

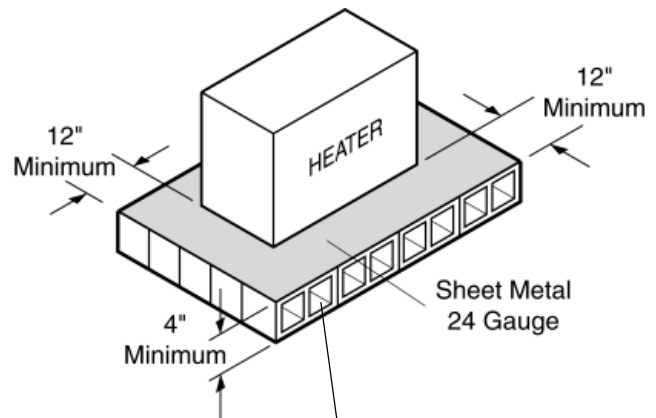

Fig.#8148.1

Hollow concrete cinder block; align holes and leave ends open. Alternative method for providing a non-combustible base.

HEATER INSTALLATION ON CONCRETE BLOCKS OR TILE

COMBUSTIBLE CONSTRUCTION CLEARANCES

The water heater should be positioned to provide the minimum clearances from combustible surfaces and to provide sufficient space for servicing the unit as follows.

MINIMUM CLEARANCES:

Clearances to surfaces installed in rooms which are large (2) in comparison with size of heater.

		PROTECTED SURFACES								
Combustible Surfaces		(a) 3 1/2-in. thick masonry wall without ventilated air space	(b) 1/2-in. insulation board over 1-in. glass fiber or mineral wool batts	(c) 0.024 sheet metal over 1-in. glass fiber or mineral wool batts reinforced with wire on rear face with ventilated air space	(d) 3 1/2-in. thick masonry wall with ventilated air space	(e) 0.024 sheet metal with ventilated air space	(f) 1/2-in. thick insulation board with ventilated air space	(g) 0.024 sheet metal with ventilated air space over 0.024 metal with ventilated air space	(h) 1-in. glass fiber or mineral wool batts sandwiched between two sheets 0.024 sheet metal with ventilated air space	
136	Rear	12"	9	6	4	6	4	4	4	4
	Left Side	12"	9	6	4	6	4	4	4	4
	Right Side	6"	5	3	3	6	2	3	3	3
	Indoor Top	42"	42	42	42	42	42	42	42	42
181-399	Rear	12"	9	6	4	6	4	4	4	4
	Left Side	12"	9	6	4	6	4	4	4	4
	Right Side	12"	9	6	4	6	4	4	4	4
	Indoor Top	39"	39	39	39	39	39	39	39	39
	Outdoor Top(1)									
512-825	Rear	12	9	6	4	6	4	4	4	4
	Left Side	18	12	9	6	6	6	6	6	6
	Right Side	6	5	3	3	6	2	3	3	3
	Indoor Top	36	36	36	36	36	36	36	36	36
	Outdoor Top	(1)								
926-1826	Rear	24	16	12	8	8	8	8	8	8
	Left Side	24	16	12	8	8	8	8	8	8
	Right Side	24	16	12	8	8	8	8	8	8
	Indoor Top	24	24	24	24	24	24	24	24	24
	Outdoor Top	(1)								

(1) Unobstructed.

(2) Large rooms are defined as having a volume at least 16 times the total volume of the heater.

(3) Installation clearances for heaters in rooms **not large** in comparison with the heater size shall be as listed under combustible surfaces and shall not be reduced by the protection methods.

SERVICING CLEARANCES:

24" in front of heater for removal of burner tray.

18" on side opposite water connection for delimiting of Heat Exchanger on Models 181-1826 only.

COMBUSTION AND VENTILATION AIR SUPPLY

CAUTION: Combustion air must not be contaminated by corrosive chemical fumes which can damage the heater and void the warranty.

IMPORTANT: Adequate air must be provided for proper combustion and ventilation of the surrounding area. An inadequate supply of combustion air will result in incomplete combustion and eventual sooting of the heater. Insufficient ventilation will cause excessive heat and rapid deterioration of electronic and electrical components. Equipment rooms should be provided with **TWO** permanent air supply openings **directly connected** to outside air. **Each** opening must have a minimum **FREE** area of one square inch per 4000 BTU per hour input of the **total** input rating of **all** equipment in the room. Local codes or authorities having jurisdiction should be consulted for the following table.

RECOMMENDED MINIMUM AIR OPENINGS

BOILER SIZE	NET FREE AREA	BOILER SIZE	NET FREE AREA	BOILER SIZE	NET FREE AREA
136	34	512	128	1125	282
181	47	627	157	1223	306
264	66	726	182	1337	335
331	84	825	207	1467	367
399	100	962	241	1630	408
All area shown in square inches				1826	457

For other conditions refer to the latest edition of the National Fuel Gas Code ANSI Z 223.1. Net free area, sq. in. requires data from louver manufacturer based on resistance of screening, if provided.

OUTDOOR INSTALLATIONS

MODEL 136

- Step 1: Remove the front (4) screws
- Step 2: Line up outdoor top vent opening over heater vent opening.
- Step 3: Lower outdoor top onto unit lining up slots in the outdoor top with screws holes in jacket top.
- Step 4: Reinstall (5) screw to secure jacket top and outdoor top to unit.

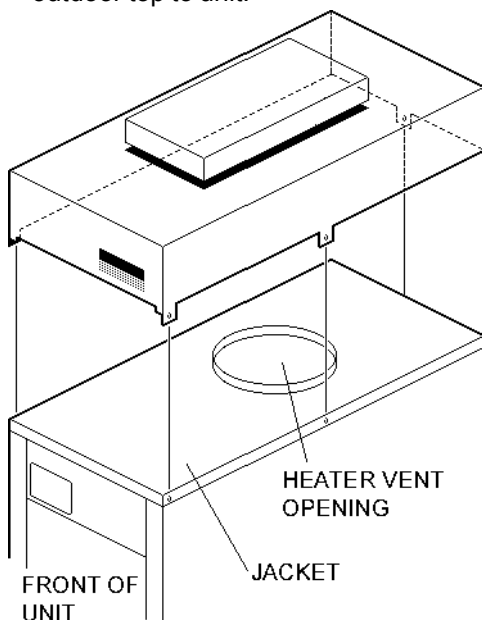
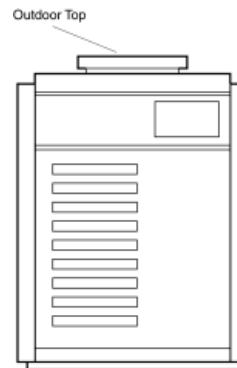

Fig. #8114

MODEL 181-399



VENT TERMINAL (Outdoor) Stackless Top Installation

1. Insert tabs into keyhole (4 places).

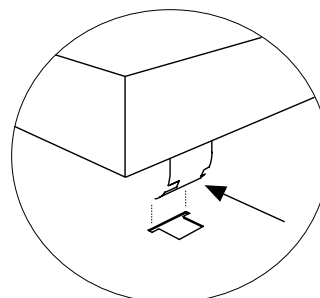

Pagoda Top
(Shipped
Loose with
Heater)

- Snap tabs into keyholes so as not to pull out.

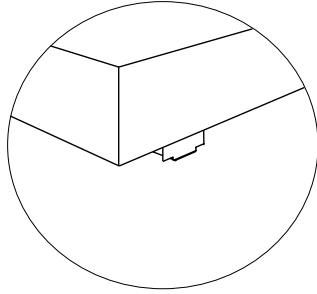

MODELS 512 - 825

- Step 1: Lower outdoor "Stackless" top on to unit. Position top so it is centered on unit from side to side and front to rear.

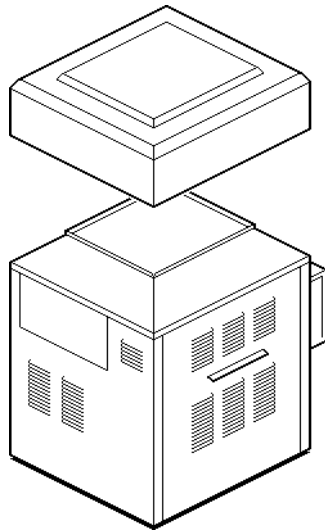

Fig. #8166.1

- Step 2: Tighten the (4) screws (Shown below) until they come in contact with the unit jacket top, then evenly tighten all (4) screws to secure to unit.

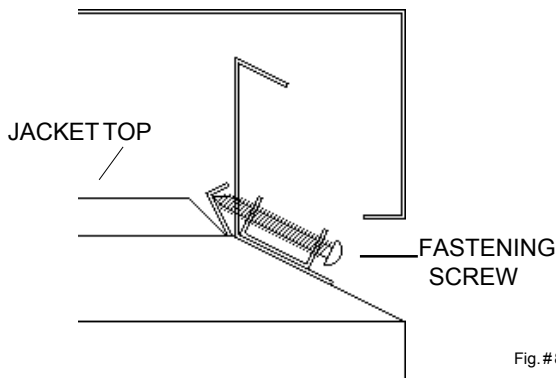

Fig. #8233

MODELS 926-1758

Heater shipped with outdoor vent terminal factory installed.

INDOOR HEATERS

Indoor Installations

MODEL 136

- Step 1: Shut off main electrical per switch to heater.
- Step 2: Turn heater manual switch located in upper control panel to the "OFF" position.
- Step 3: Shut off gas supply and water supply to the heater.
- Step 4: Mount draft hood on boiler and attach with the 4 sheet metal screws provided. Draft hood should be positioned with the vent sensor located on the front left side as shown.
- Step 5: Remove plastic plug from left side of boiler jacket and install the plastic grommet provided.
- Step 6: Route flue sensor wire harness through the grommet installed in Step 5.

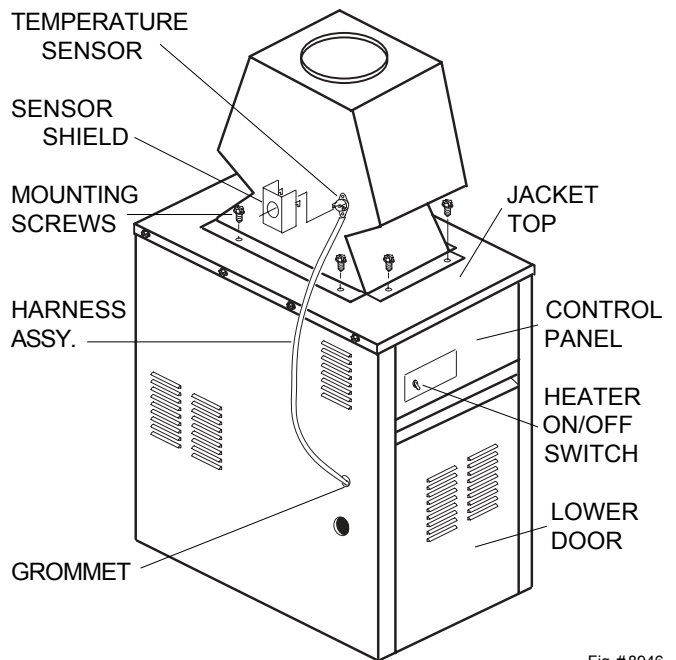

Fig. #8946

Step 7: Remove door and locate wire from roll out sensor to Hi Limit with the male/female connector.

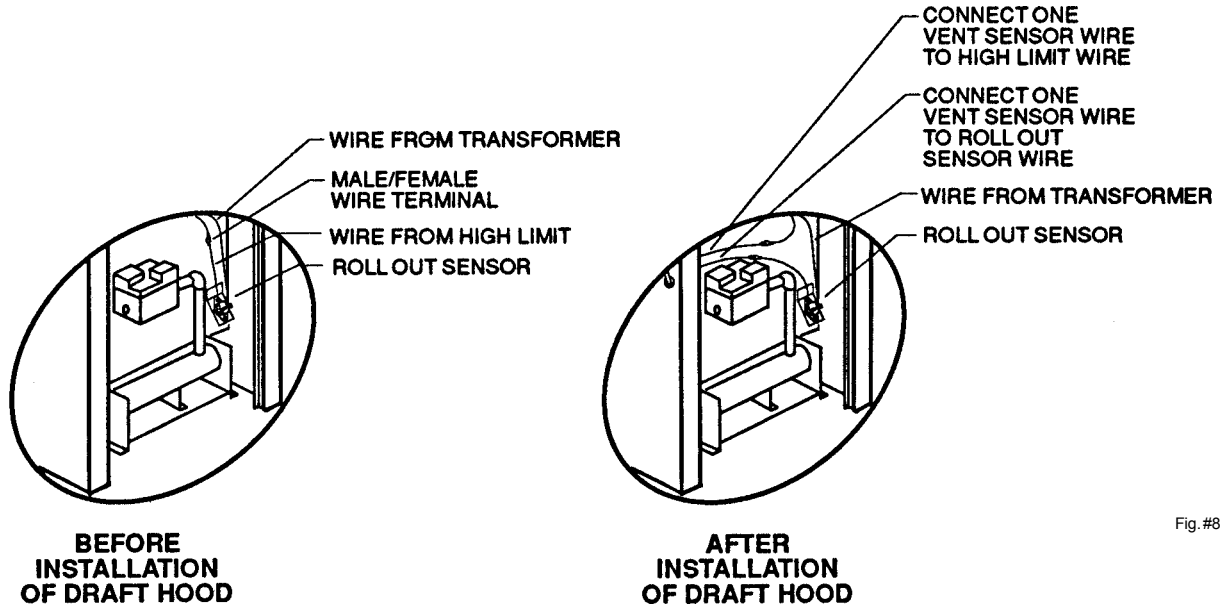

Fig. #8947

Step 8: Disconnect male/female connector and attach to the 2 wires from draft hood vent sensor harness.

MODELS 181-399 VENT TERMINAL/INDOOR STACK INSTALLATION

1. Remove the louvered jacket top by removing four (4) #10 flat head screws.
2. If originally installed, remove "Pagoda" top from the louvered jacket top.
3. Place the inner stack adapter panel over the flue collector inside the heater. Make sure the flanged side of the flue opening is up.
4. Turn the stack (draft hood) upside down and set it down bottom side up.
5. Turn the jacket top panel (removed in step 1) upside down and place it through the stack.
6. Attach the three (3) mounting brackets to the stack using the screws provided and the holes that are pre-drilled in the stack. **Make sure the brackets are positioned with the flange near the top side of the stack (see illustration).** *Caution must be taken not to over tighten and strip the screw threads.*
7. Turn the assembled stack and jacket top, right side up. The jacket top will be trapped between the brackets and the top of the stack. Place the stack over the inner adapter panel flanged hole and lower the louvered jacket top panel back into its original position. Reinstall the four (4) green #10 flat head screws removed in step 1 above.

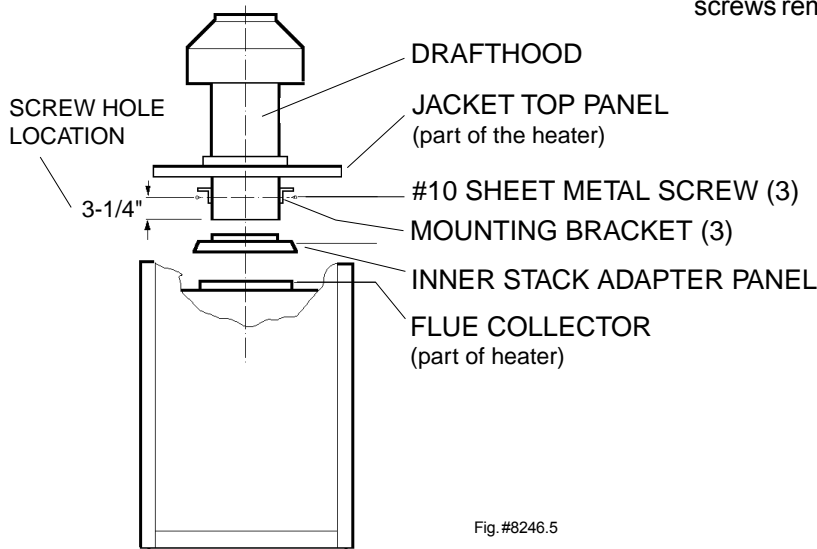
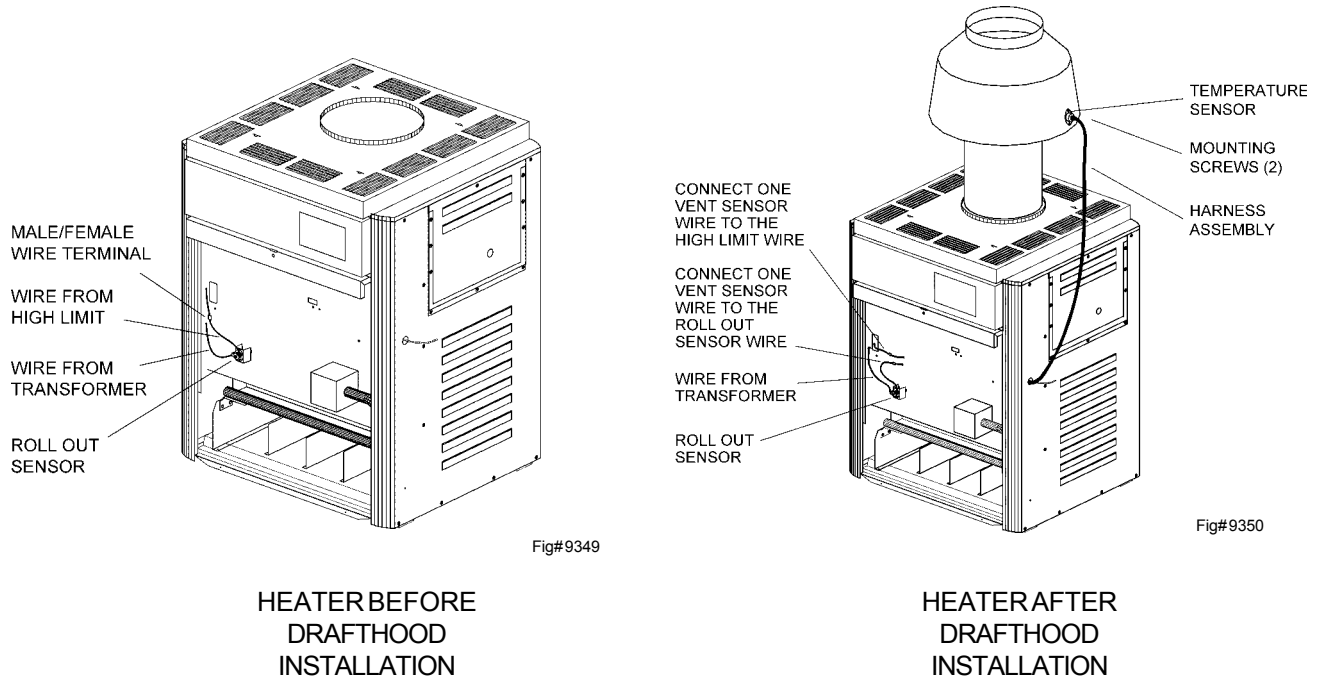

Fig. #8246.5

MODELS 181-399

- Step 1. Shut off main electrical power switch to heater.
- Step 2. Turn heater manual switch located in upper control panel to the "OFF" position.
- Step 3. Shut off gas supply and water supply to the heater.
- Step 4. Mount drafthood on top of boiler as shown on page 8. Drafthood should be positioned with the vent sensor located on the front right side as shown.
- Step 5. Remove plastic plug from left side of boiler jacket and install plastic grommet provided.
- Step 6. Route flue sensor wire harness through the grommet installed in Step 5.
- Step 7. Remove door and locate wire from roll out sensor to hi limit with the male/female connector.
- Step 8. Disconnect male/female connector and attach to the 2 wires from draft hood vent sensor harness.



MODELS 512 - 825

Locate and assemble as shown below. Secure with screws supplied in envelope in carton

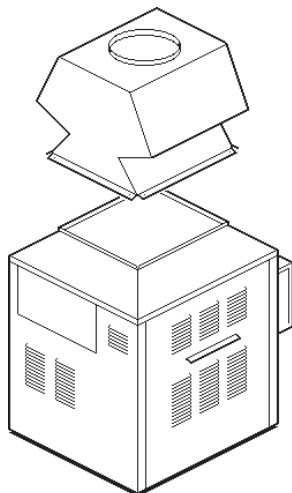

Fig. #8167.0

MODELS 962 - 1826

Locate and assemble as shown below. Secure with screws supplied in envelope in carton.

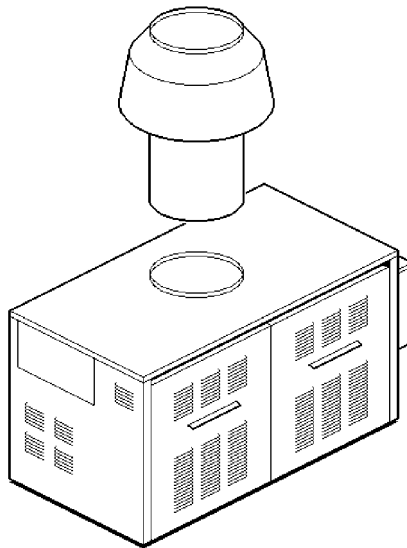

Fig. #8265.0

WARNING:

Indoor heaters require a draft hood that must be connected to a vent pipe and properly vented to the outside. Failure to follow this procedure can cause fire or fatal carbon monoxide poisoning.

Vent piping the same size or larger than the draft hood outlet is recommended, however, when the total vent height is at least ten (10) feet (draft hood relief opening to vent terminal), the vent pipe size may be reduced as specified in Chapter 10 of the National Fuel Gas Code, ANSI Z223.1. As much as possible avoid long horizontal runs of vent pipe and too many elbows. If installation requires horizontal non-vertical runs, the vent pipe must have a minimum of 1/4 inch per foot rise and should be supported at not less than five foot intervals. Plumbers tape, criss-crossed, will serve to space both horizontal and vertical piping. Gas vents supported only by the flashing and extending above the roof more than five feet should be securely guyed or braced to withstand snow and wind load. We recommend use of insulated vent pipe must terminate with a vent cap which complies with the local codes or, in the absence of such codes, to the latest edition of the National Fuel Gas Code, **ANSI Z223.1**.

The discharge opening must be a minimum of three feet vertically from the roof surface and at least two feet higher than any part of the building within ten feet. Vent stack shall be at least five feet in vertical height above the draft hood outlet. The vent cap location shall have a minimum clearance of 4 feet horizontally from, and in no case above or below, unless a 4-foot horizontal distance is maintained, from electric meters, gas meters regulators and relief equipment.

The weight of the vent stack or chimney must not rest on the heater draft hood. Support must be provided in compliance with applicable codes. The heater top and draft hood must be readily removable for maintenance and inspection. Vent pipe should be adequately supported to maintain proper clearances from combustible construction.

Type "B" double wall or equivalent vent pipe is recommended. However single wall metal vent pipe may be used as specified in the latest edition of the National Flue Gas Code **ANSI Z223.1**.

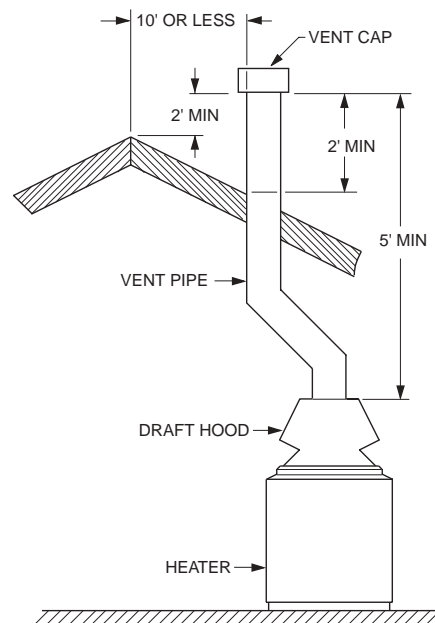
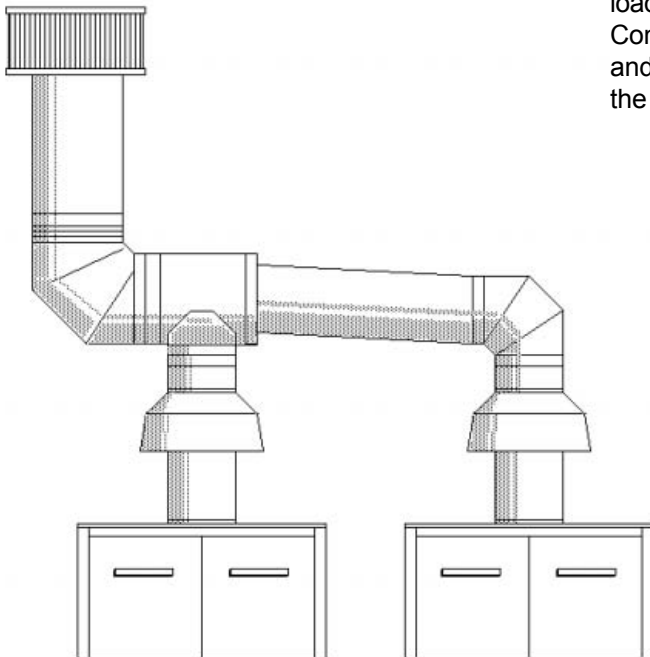

Fig # 8119

At the time of removal of an existing heater, the following steps shall be followed with each appliance remaining connected to the common venting system placed in operation, while the other appliances remaining connected to the common venting system are not in operation.

- (a) Seal any unused openings in the common venting system.
- (b) Visually inspect the venting system for proper size and horizontal pitch and determine there is no blockage or restriction, leakage, corrosion and other deficiencies which could cause an unsafe condition.
- (c) Insofar as is practical, close all building doors and windows and all doors between the space in which the appliances remaining connected to the common venting system are located and other spaces of the building. Turn on clothes dryers and any appliance not connected to the common venting system. Turn on any exhaust fans, such as range hoods and bathroom exhausts, so they will operate at maximum speed. Do not operate a summer exhaust fan. Close fireplace dampers.
- (d) Place in operation the appliance being inspected. Follow the lighting instructions. Adjust thermostat so appliance will operate continuously.
- (e) Test for spillage at the draft hood relief opening after 5 minutes of main burner operation. Use the flame of a match or candle, or smoke from a cigarette, cigar or pipe.
- (f) After it has been determined that each appliance remaining connected to the common venting system properly vents when tested as outlined above, return doors, windows, exhaust fans, fireplace dampers and any other gas burning appliance to their previous conditions of use.
- (g) Any improper operation of the common venting system should be corrected so the installation conforms with the latest edition of the National Fuel Gas Code, ANSI Z223.1. When resizing any portion of the common venting system, the common venting system should be resized to approach the minimum size as determined using the appropriate tables in Part 11 of the National Fuel Gas Code, ANSI Z223.1.



Manifolds that connect more than one heater to a common chimney must be sized to handle the combined load.

Consult available guides for proper sizing of the manifold and the chimney. At no time should the area be less than the area of the largest outlet.

Fig.#7043.1

POWER VENTING

Heaters may be connected to systems requiring mechanical draft exhaust fans. The installation must be engineered by competent personnel in accordance with the latest edition of ANSI Z 223.1, local codes and with the supplier of the fan.

Particular attention must be given to the type of vent pipe used, its size and location. Suitable interlocks must be provided to prevent heater operation until the fan is operating as designed.

OUTDOOR WATER HEATERS

The point from where the flue products exit the heater must be a minimum of four (4) feet below, four (4) feet horizontally from or one (1) foot above any door, window or gravity inlet to a building. The top surface of the heater shall be at least three (3) feet above any forced air inlet, or intake ducts located within ten (10) feet horizontally.

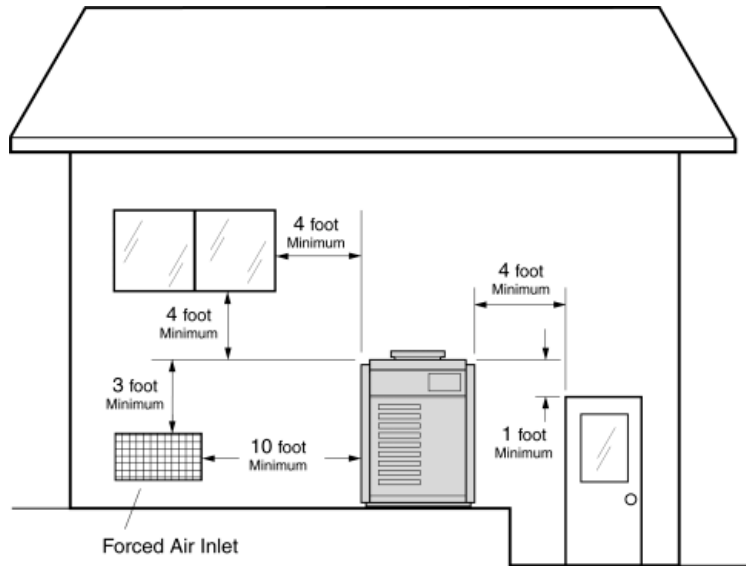

Fig.#8245.1

HIGH WIND CONDITIONS (Outdoor Units Only)

In areas where high winds are frequent, it may be necessary to locate the heater a minimum of 3' from high vertical walls, or install a wind break so the heater is not in direct wind current.

VENT DAMPER INSTALLATION

(MODELS 136 THROUGH 264) *WHERE REQUIRED*

LOCATION

The vent damper must be located in the vent so that it serves only the appliance for which it is intended.

If improperly installed, a hazardous condition, such as an explosion or carbon monoxide poisoning, could result. Make certain that it is mounted in an accessible location at least 6 in. (152.4 mm) from any combustible material or the heat exchanger and that the position indicator is in a visible location.

The vent damper must be installed after the appliance draft hood, as close to the draft hood as practicable, and without modification of the draft hood.

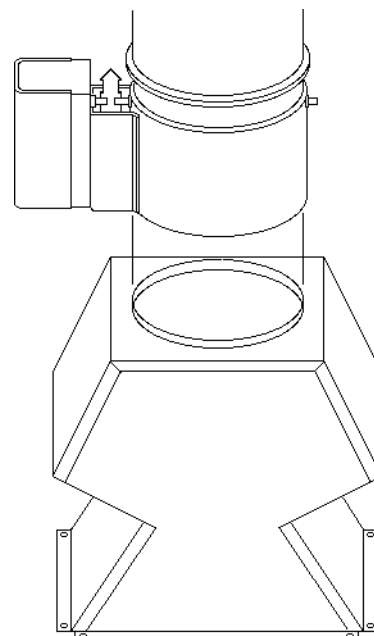

Fig.#8182.0

MOUNTING

On vertical vents, the vent damper may be mounted with the actuator in any position. On horizontal vents, do not mount the actuator either directly above or directly below the vent pipe; mount the vent damper actuator to the side of the vent.

The vent damper is set up for a continuous pilot system. If the vent damper is installed on an intermittent Pilot or Direct Spark Ignition equipped system, the energy savings of the vent damper can be improved by plugging the hole in the vent damper blade using the knockout plug, Part No 105612R, provided in the parts envelope.

DO NOT plug the hole if installing the vent damper on a continuous pilot system as this will create a hazardous condition.

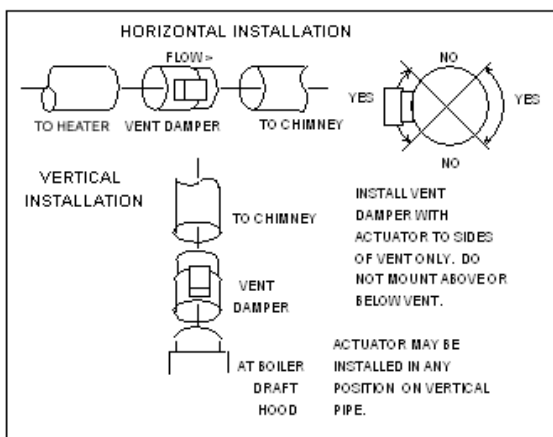

INSTALLING THE VENT DAMPER IN HORIZONTAL & VERTICAL VENTS.

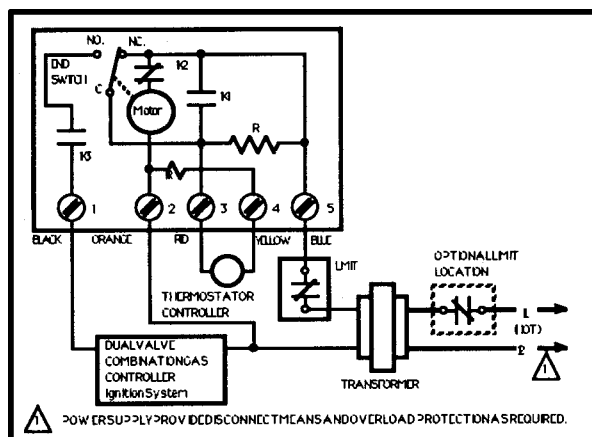

D80B GENERAL WIRING DIAGRAM

INSTALL THE VENT DAMPER TO SERVICE ONLY THE SINGLE APPLIANCE FOR WHICH IT IS INTENDED. IF IMPROPERLY INSTALLED, A HAZARDOUS CONDITION, SUCH AS AN EXPLOSION OR CARBON MONOXIDE POISONING, COULD RESULT.

VENT DAMPER

NORMAL OPERATION SUMMARY

For safe, efficient operation, the vent damper and all flue product carrying areas of the appliance must be checked annually, with particular attention given to deterioration from corrosion or other sources. Check vent damper operation as follows:

1. When the furnace or heater is off, check that the vent damper position indicator points to the closed position, Fig. 4.
2. Turn the thermostat or controller up to call for heat and check that the vent damper indicator points to the open position, Fig. 4.
3. Turn the thermostat or controller down again and check that the vent damper position indicator returns to the closed position.

THE VENT DAMPER MUST BE INSPECTED AT LEAST ONCE A YEAR BY A TRAINED, EXPERIENCED SERVICE TECHNICIAN.. THE NAME OF THE PERSON WHO ORIGINALLY INSTALLED YOUR VENT DAMPER IS SHOWN ON THE INSTALLATION LABEL. DAMPER MUST BE IN OPEN POSITION WHEN HEATER MAIN BURNERS ARE OPERATING.

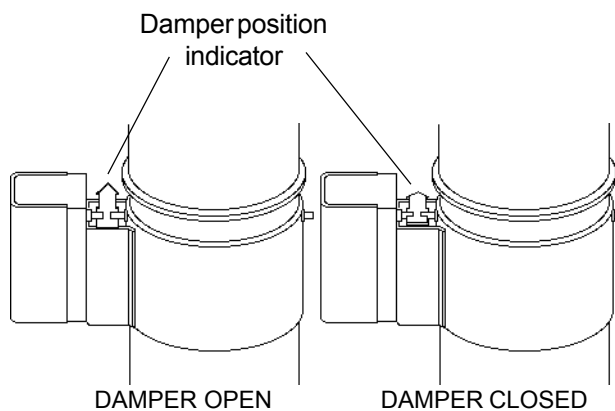

FIG.4-VENT DAMPER POSITION INDICATOR SHOWING OPEN & CLOSED POSITIONS.

PIPING: General. Consult particular heater section for specific information.

a. GAS

Gas piping must be installed in accordance with the latest edition of the **National Fuel Gas Code ANSI Z-223.1** and other local or regulatory agency codes that have jurisdiction.

1. Check heater rating plate for
 - Correct Fuel Gas
 - Rated input to meet local conditions such as altitude, gas specification, etc.
2. Piping from meter must be of sufficient size to provide the required amount of gas at flowing pressures as follows:

Gas	Natural	Propane
BTU/CF	1000	2500
SP. GR	0.60	1.53
Minimum Flowing Pressure	7" W.C.	12" W.C.
Maximum Shut-off Pressure	14" W.C.	14" W.C.

PIPE SIZES

Fuel Length(feet)	Nat.			Propane		
	0-100	100-200	200-300	0-100	100-200	200-300
Model						
136	3/4	1	1-1/4	3/4	1	1
181	1	1-1/4	1-1/4	1	1	1-1/4
264	1-1/4	1-1/4	1-1/2	1	1-1/4	1-1/4
331	1-1/4	1-1/2	1-1/2	1-1/4	1-1/4	1/1/2
399	1-1/4	1-1/2	1-1/2	1-1/4	1-1/4	1-1/2
512	1-1/2	2	2	1-1/4	1-1/2	1-1/2
627	1-1/2	2	2	1-1/2	1-1/2	2
726	2	2	2	1-1/2	2	2
825	2	2	2-1/2	2	2	2
926	2	2-1/2	2-1/2	2	2	2
962	2	2-1/2	2-1/2	2	2	2
1083	2	2-1/2	2-1/2	2	2	2
1125	2	2-1/2	2-1/2	2	2	2
1178	2-1/2	2-1/2	3	2	2	2-1/2
1223	2-1/2	2-1/2	3	2	2	2-1/2
1287	2-1/2	3	3	2	2-1/2	2-1/2
1337	2-1/2	3	3	2	2-1/2	2-1/2
1413	2-1/2	3	3	2	2-1/2	2-1/2
1467	2-1/2	3	3	2	2-1/2	2-1/2
1570	2-1/2	3	3	2	2-1/2	3
1630	2-1/2	3	3	2	2-1/2	3
1758	2-1/2	3	3	2	2-1/2	3
1826	2-1/2	3	3	2	2-1/2	3

Chart is based on: 0.5" W.C. Pressure Drop Natural Gas
0.6" W.C. Pressure Drop Propane Gas

Fitting provided in gas line have equivalent length of pipe, in feet, as follows:

Size	3/4	1	1-1/4	1-1/2	2	2-1/2	3	4
Elbow	2.5	3	4	4.5	5.5	6.5	8	12
Tee	5	6	8	9	12	14	17	22

3. All gas piping must be tested after installation with air or an inert gas and all connections should be checked using a soapy solution.

CAUTION: The heater and its manual shut off valve must be disconnected from the gas supply during any pressure testing of that system at test pressures in excess of 1/2 psig (3.45 KPA). Dissipate test pressure in the gas supply line before reconnecting the heater and its manual shut off valve to gas supply line. FAILURE TO FOLLOW THIS PROCEDURE MAY DAMAGE THE GAS VALVE. OVER PRESSURED GAS VALVES ARE NOT COVERED BY WARRANTY. The heater and its gas connections shall be leak tested before placing the appliance in operation. Use soapy water for leak test. Do NOT use open flame.

Test piping as follows:

Pressure 1/2 PSIG (14" W.C.) or less - isolate heater by closing the manual shut-off valve prior to applying pressure.

Pressure in excess of 1/2 PSIG (14" W.C.) - The heater must be disconnected from the gas system.

Water heaters having gas train components that have diaphragms in their construction are supplied with a bleed line connection that must be connected to the outside atmosphere as required by the National Fuel Gas Code. Under **NO** circumstances shall bleed lines terminate in the gas utilization equipment flue or exhaust system.

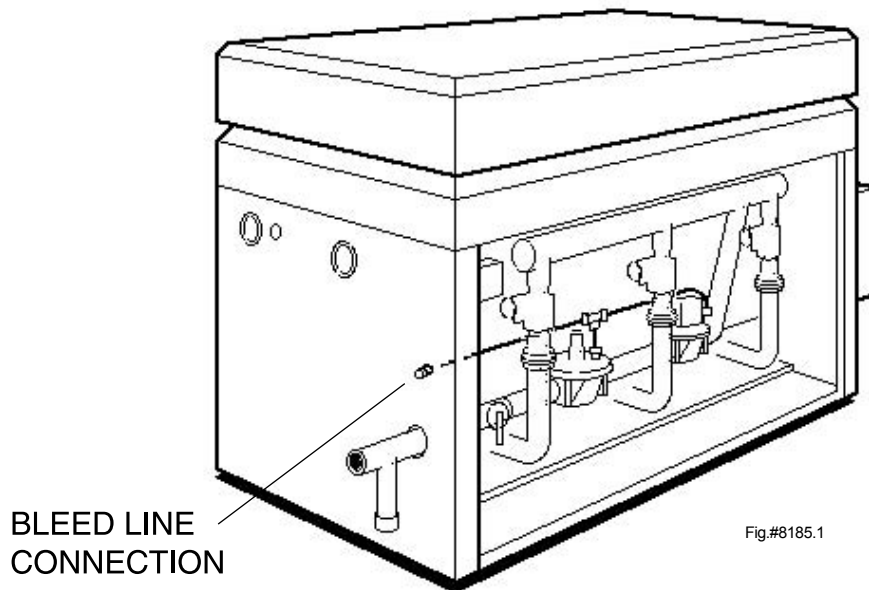

Burner Manifold Pressures. The gas pressure regulator supplied with the heater is factory set to provide a manifold pressure, as measured with a manometer, of 3.7 in. W.C. for Natural Gas and 10.5 in. W.C. for Propane. If adjustment is required to obtain these pressures remove cap and turn screw clockwise to increase pressure, counter-clockwise to decrease pressure.

b. WATER

Water piping should be installed according to the local code requirements, ASHRAE, ASPE and BOCA or other regulatory agencies.

COLD WATER SUPPLY

The cold water supply piping, to the heater must be adequate to handle the design load requirements of the hot water system. The following table illustrates the flow and minimum pipe sizes.

Model Size	Flow GPM	Min Pipe NPT	Model Size	Flow GPM	Min Pipe NPT	Model Size	Flow GPM	Min Pipe NPT
136	22	1-1/4	825	85	2	1413	90	2-1/2
181	30	1-1/2	926	90	2-1/2	1467	90	2-1/2
264	42	1-1/2	962	90	2-1/2	1570	90	2-1/2
331	53	1-1/2	1083	90	2-1/2	1630	90	2-1/2
399	63	1-1/2	1125	90	2-1/2	1758	90	2-1/2
512	82	2	1178	90	2-1/2	1826	90	2-1/2
627	85	2	1287	90	2-1/2			
726	85	2	1337	90	2-1/2			

It is recommended that a gate valve be installed in the cold water supply line adjacent to the heater. If Local Codes require a check valve - provisions must be made for thermal expansion.

A **minimum** pressure of 30 PSIG must be maintained in the system to prevent damage to the heater due to lack of water circulation caused by vapor formation at suction side of the system pumps.

NOTE: Should the cold water supply be interrupted, for any reason, the gas supply must be manually shut off to prevent heater damage. When the service is restored the lines must be vented to eliminate accumulated air.

HOT WATER SUPPLY HEATER

Model 136- 1826

The heater is direct fired and used with a storage tank. The model number indicates the BTU/holds input. (i.e. an 1826 holds input of 1,826,000 BTU/ HR)

See specification and dimension information on pages 4, 5 and 6.

TANK TEMPERATURE CONTROL

1. The tank temperature controller is shipped loose for installation in the field. It is found in the burner tray.
2. Install in the tapping provided in the storage tank as shown.
3. Wire the "TH" leads, provided in the boiler control box, to the tank temperature controller. **DO NOT WIRE IN SERIES WITH 115 VOLT SUPPLY TO THE HEATER.**

NOTE: The "TH" wires are in the 24 volt control circuit. DO NOT connect to the 115 volt circuit.

4. Set temperature to 140°F or to desired tank temperature.

SEQUENCE OF OPERATION

1. Power to heater and recirculation pump.
2. Control switch, located on heater control box, placed in "ON" position.
 - a. High limit controller circuit closed.
 - b. Tank temperature controller calls for heat.
 - c. Pump relay energized starting heater pump.
 - d. Flow switch activated, if sufficient flow is determined, sending power to
 - e. The ignition relay, S8600.
 - f. The pilot is energized and when proven lit.
 - g. Spark to pilot stops and
 - h. The main gas opens allowing the burners to light.
3. Tank temperature reaches desired temperature.
 - a. Controller opens circuit.
 - b. Ignition relay de-energizes shutting off main and pilot gas.
 - c. Heater pump continues to operate until residual heat in the heater is dissipated.
 - d. Stack temperature drops below 140°F. A stack sensor, a part of the energy saving control, opens the pump relay circuit shutting down pump.
4. Heater waits for next call for heat.

INSTALLATION WATER HEATER PLUMBING:

The Recirculation pump, supplied by the installer should be sized according to heater input Model # ie. 825 would require 8.25 GPM. This pump is in addition to the pump supplied with the heater. The pump should be set for constant recirculation. **DO NOT WIRE** to heater or tank operating controls.

PIPING DIAGRAM-1 HEATER 1 TANK THERMOSTAT SUPPLIED

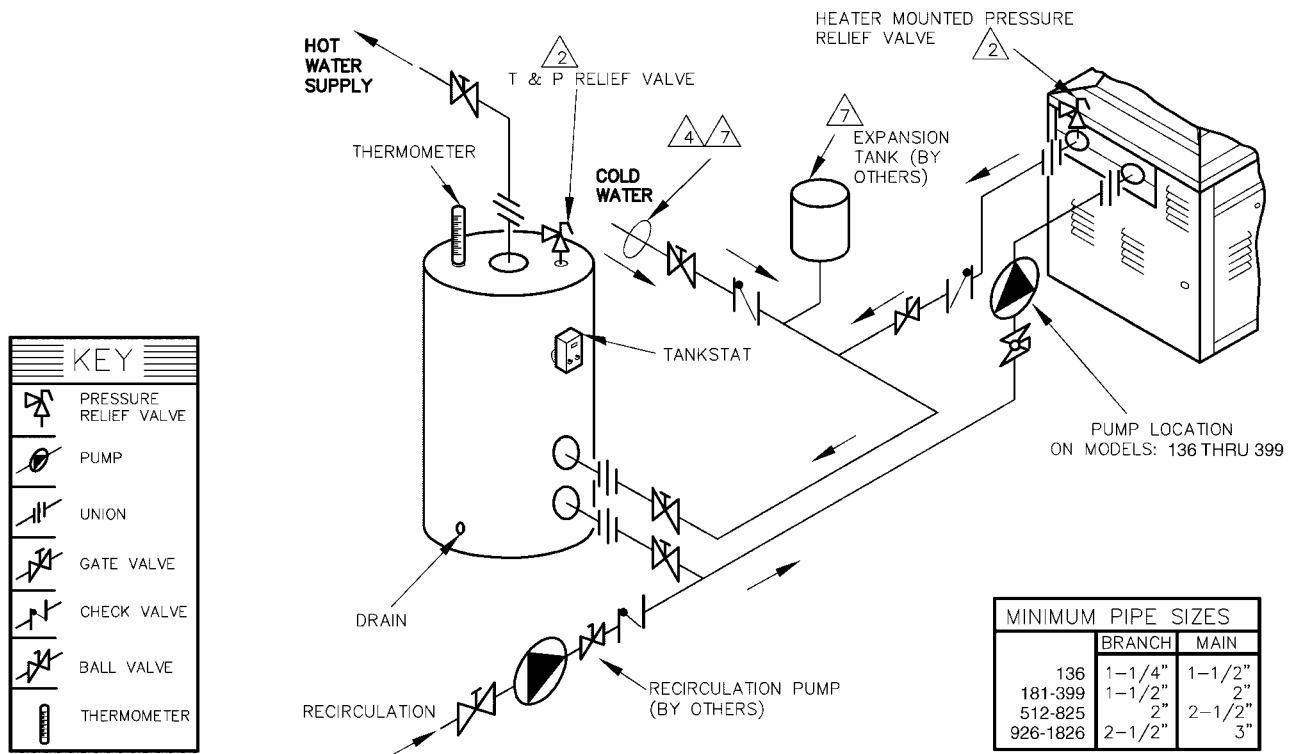

NOTES:

1. PLUMB SWING CHECK VALVE IN GRAVITY CLOSED POSITION.
2. PIPE ALL RELIEF VALVES TO DRAIN, OR AS LOCAL CODES REQUIRE.
3. LOCATE TEE AS CLOSE AS POSSIBLE TO TANK.
4. INSTALL COLD WATER BETWEEN HEATER OUTLET AND TANK.
5. SEE CHART "MINIMUM PIPE SIZES" FOR MINIMUM PIPE SIZES.
6. SIZING BASED ON HEATER AND TANK BEING PLACED FIVE FEET APART, IF DISTANCE IS GREATER, THE PUMP MUST BE SIZED TO ACCOMMODATE INCREASE IN PIPING RELATED LOSSES.
7. PROVIDE FOR THERMAL EXPANSION OF HOT WATER IF A BACKFLOW PREVENTER, CHECK VALVE, WATER METER OR PRESSURE-REDUCING VALVE IS INSTALLED IN THE COLD WATER LINE.

Fig. #8054-RHEEM

PIPING DIAGRAM-1 HEATER 2 TANK

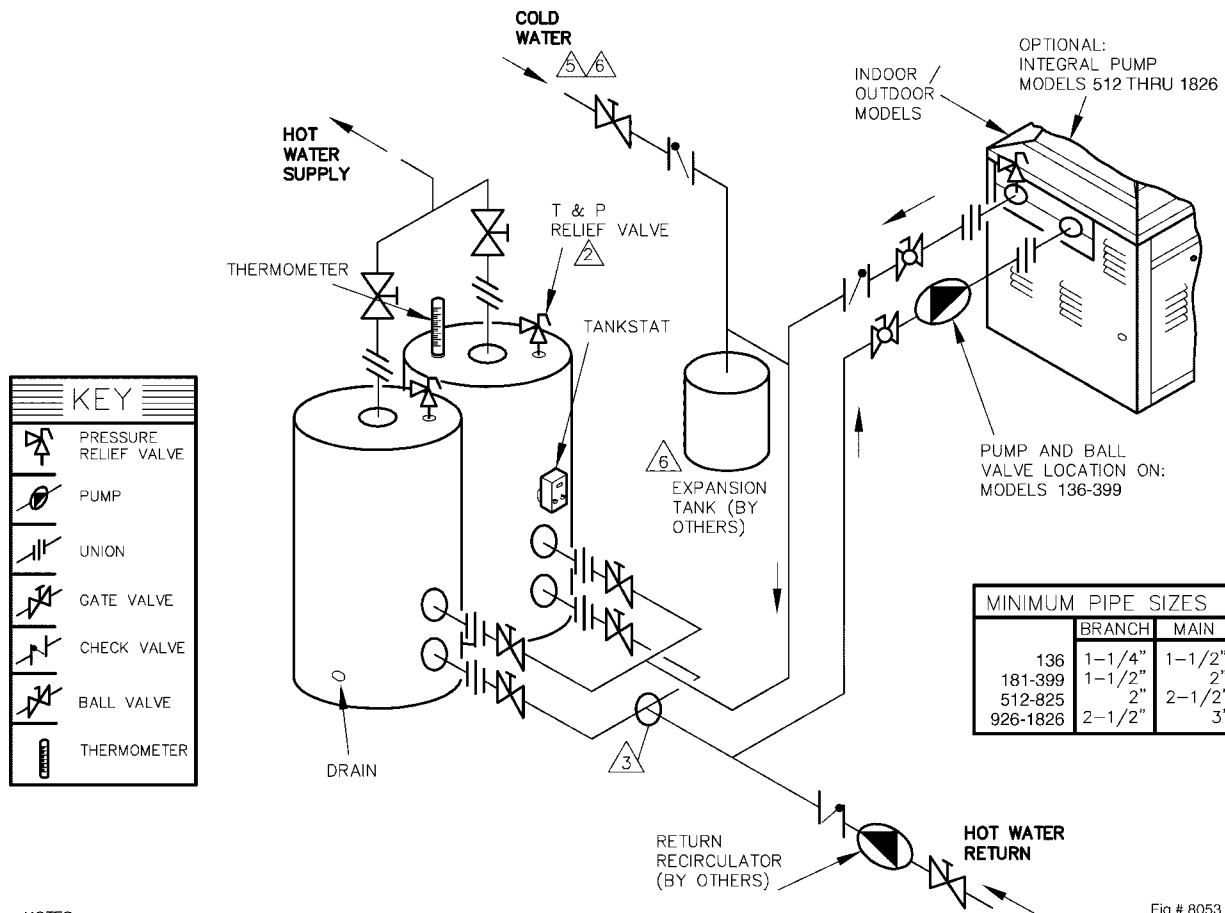

Fig # 8053 Rheem

* PIPING MUST BE EQUAL BETWEEN TEES AND TANKS.

NOTES:

1. Plumb all swing check valves in gravity closed position.
2. Minimum pipe size equal to heater inlet/outlet connection size (between heater and tanks).
3. Pipe sizes between tanks are to be based on estimated GPM flow rates (Max. 10 FPS Vel.)
4. Pipe all relief valves to drain or as local codes require.
5. Duplex manifold kit & 115 gallon jacketed and insulated storage tanks available from factory.

PIPING DIAGRAM-1 HEATER 3 TANK

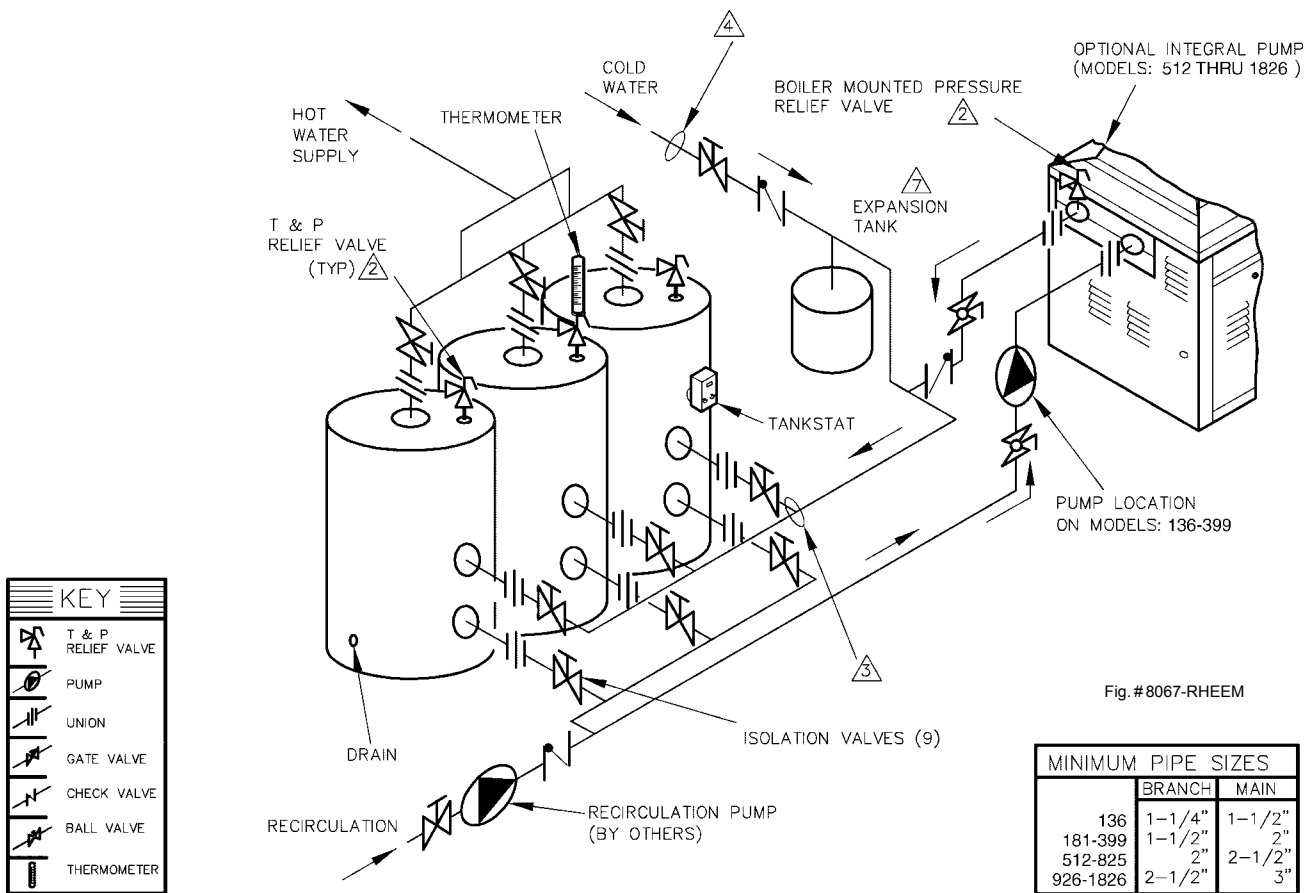

Fig. #8067-RHEEM

NOTES:

1. PLUMB SWING CHECK VALVE IN GRAVITY CLOSED POSITION.
2. PIPE ALL RELIEF VALVES TO DRAIN, OR AS LOCAL CODES REQUIRE.
3. LOCATE TEE AS CLOSE AS POSSIBLE TO TANK.
4. INSTALL COLD WATER BETWEEN HEATER OUTLET AND TANK.
5. SEE CHART "MINIMUM PIPE SIZES" FOR MINIMUM PIPE SIZES.
6. SIZING BASED ON HEATER AND TANK BEING PLACED FIVE FEET APART, IF DISTANCE IS GREATER, THE PUMP MUST BE SIZED TO ACCOMMODATE INCREASE IN PIPING RELATED LOSSES.
7. PROVIDE FOR THERMAL EXPANSION OF HOT WATER IF A BACKFLOW PREVENTER, CHECK VALVE, WATER METER, OR PRESSURE REDUCING VALVE IS INSTALLED IN THE COLD WATER LINE.

* PIPING MUST BE EQUAL BETWEEN TEES AND TANKS.

NOTES:

1. Plumb all swing check valves in gravity closed position.
2. Minimum pipe size equal to heater inlet/outlet connection size (between heater and tanks).
3. Pipe sizes between tanks are to be based on estimated GPM flow rates (Max. 10 FPS Vel.)
4. Pipe all relief valves to drain or as local codes require.
5. Duplex manifold kit & 115 gallon jacketed and insulated storage tanks available from factory.

PIPING DIAGRAM-1 HEATER 4 TANK

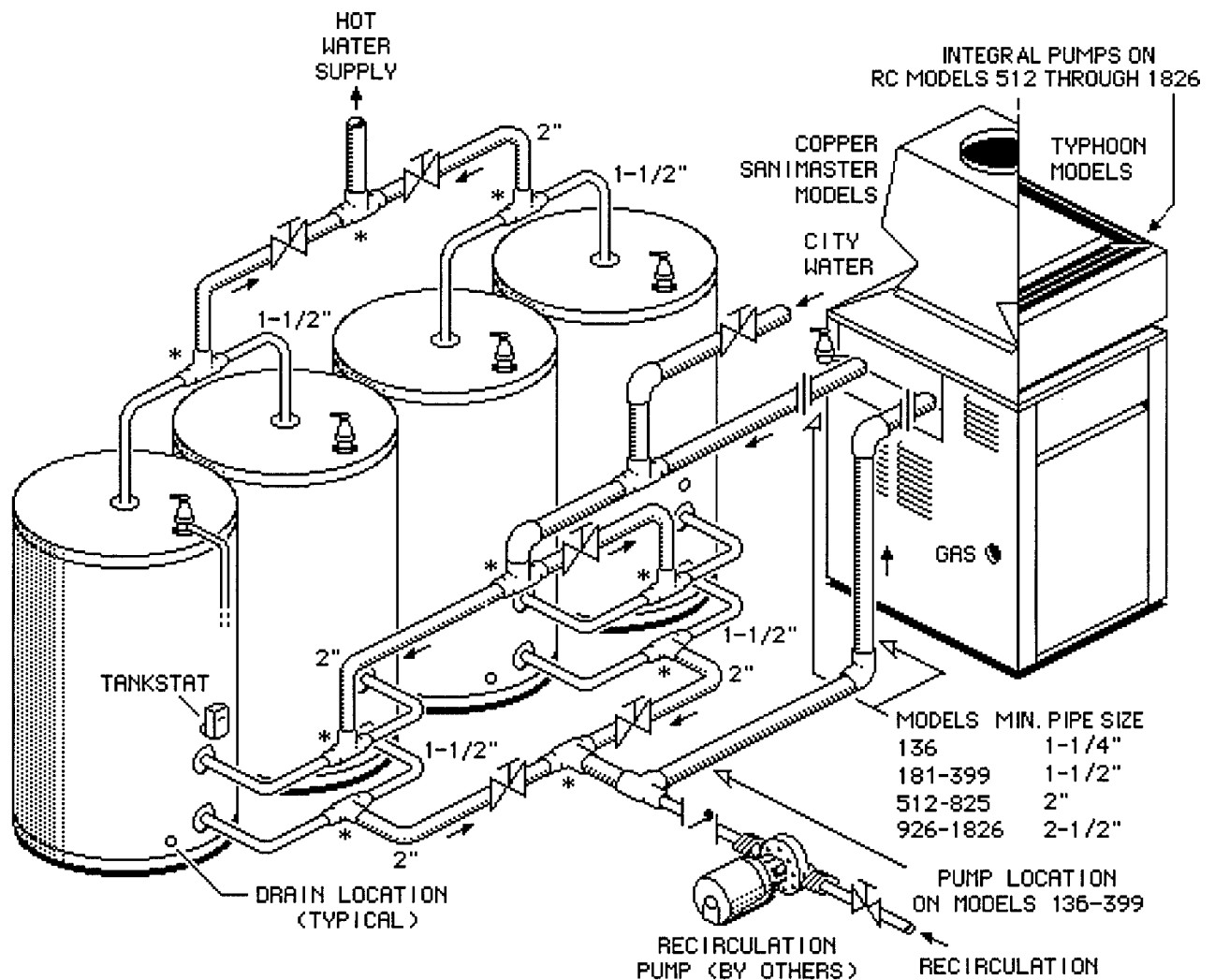

Fig. #7065

* PIPING MUST BE EQUAL BETWEEN TEES AND TANKS.

NOTES:

1. Plumb all swing check valves in gravity closed position.
2. Minimum pipe size equal to heater inlet/outlet connection size (between heater and tanks).
3. Pipe sizes between tanks are to be based on estimated GPM flow rates (Max. 10 FPS Vel.)
4. Pipe all relief valves to drain or as local codes require.
5. Duplex manifold kit & 115 gallon jacketed and insulated storage tanks available from factory.

PIPING DIAGRAM-2 HEATER 1 TANK SPECIAL THERMOSTAT AND WELL

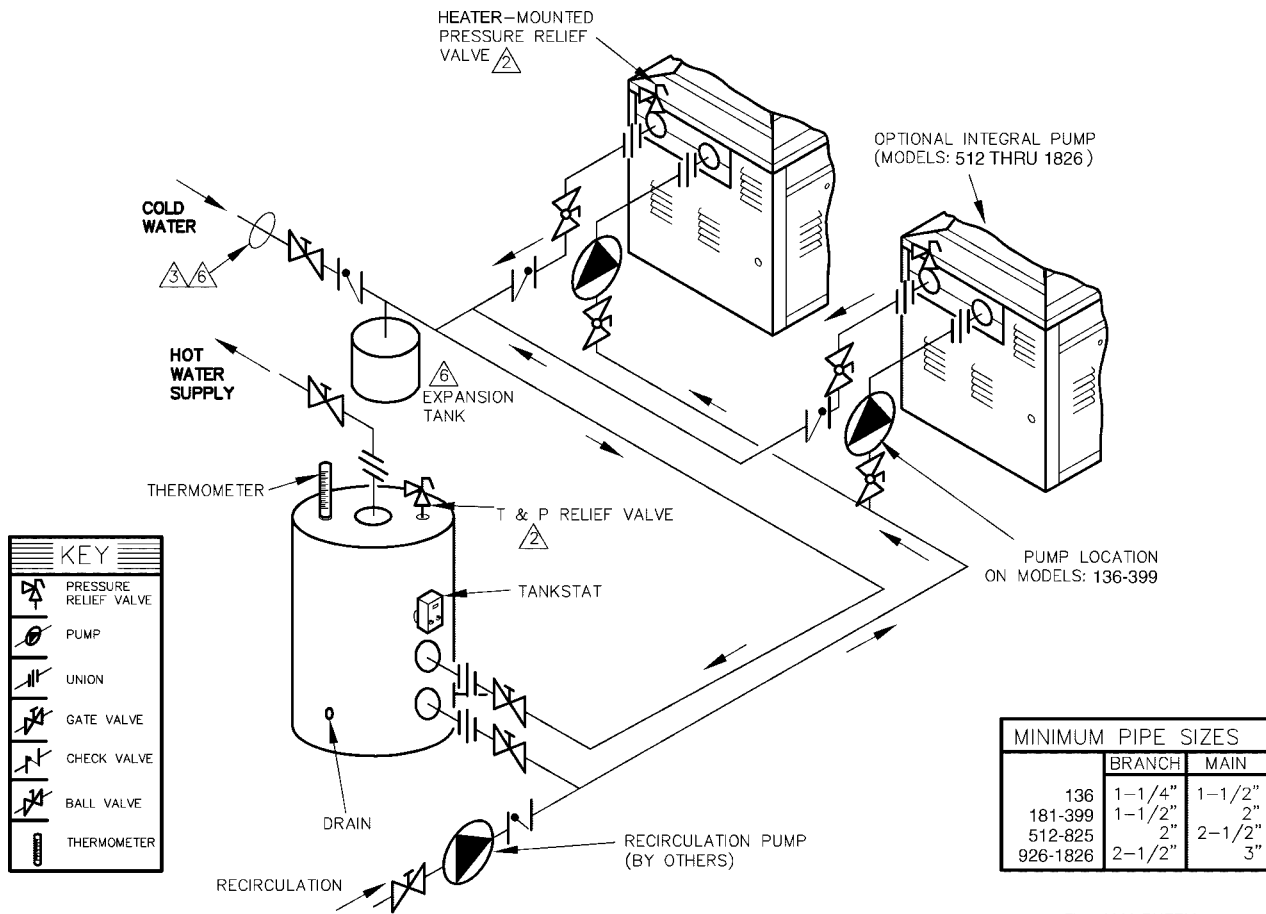

Fig # 8069-RHEEM

NOTES:

1. PLUMB SWING CHECK VALVE IN GRAVITY CLOSED POSITION.
2. PIPE ALL RELIEF VALVES TO DRAIN, OR AS LOCAL CODES REQUIRE.
3. INSTALL COLD WATER BETWEEN BOILER OUTLET AND TANK.
4. SEE CHART "MINIMUM PIPE SIZES" FOR MINIMUM PIPE SIZES.
5. SIZING BASED ON HEATER AND TANK BEING PLACED FIVE FEET APART, IF DISTANCE IS GREATER, THE PUMP MUST BE SIZED TO ACCOMMODATE INCREASE IN PIPING RELATED LOSSES.
6. PROVIDE FOR THERMAL EXPANSION OF HOT WATER IF A BACKFLOW PREVENTER, CHECK VALVE, WATER METER OR PRESSURE-REDUCING VALVE IS INSTALLED IN THE COLD WATER LINE.

NOTES:

1. Plumb all swing check valves in gravity closed position.
2. Minimum pipe size to be (1) size larger than heater inlet/outlet connection size.
3. Pipe all relief valves to drain or as local codes require.
4. 115 gallon jacketed and insulated storage tanks available from factory.
5. When two heaters are paralleled, do not use factory supplied thermostats. Order thermostat part number 600887 and Well PN 650590 from factory. See electrical wiring on page 29.
6. Heaters with 2" or 2-1/2" manifold size may require more than one storage tank. Consult factory for proper storage sizes.

DESCRIPTION OF CONTROLS IN GENERAL

ENERGY SAVING PUMP CONTROL

The energy saving pump control is an electronic device that allows the operator to set the desired time for the pump to run after the heater shuts off. The time is factory-set at 7 minutes and it can be re-adjusted in the field anywhere from 3 to 10 minutes.

In a conventional system, when the tankstat is satisfied, the main gas valve closes, but the pump continues operating. With the energy saving pump control, the heater pump is programmed to continue running for an optimum period of time in order to absorb the residual heat from the combustion chamber and use it in the system.

The pump then shuts off until the next call for heat is received from the tankstat.

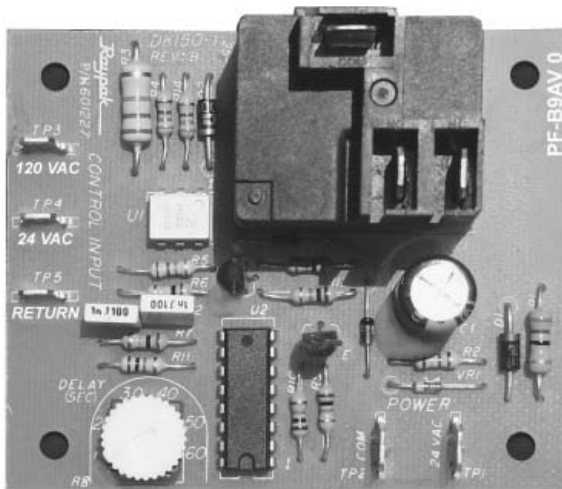

Economaster Control

Fig#9331

ELECTRONIC IGNITION

The intermittent ignition device conserves energy by automatically extinguishing the pilot when desired temperature is reached. When additional heat is needed, the pilot re-ignites electrically, eliminating costs of maintaining a constant pilot. To assure safe operation, the gas valve cannot open until the pilot lights and is proven.

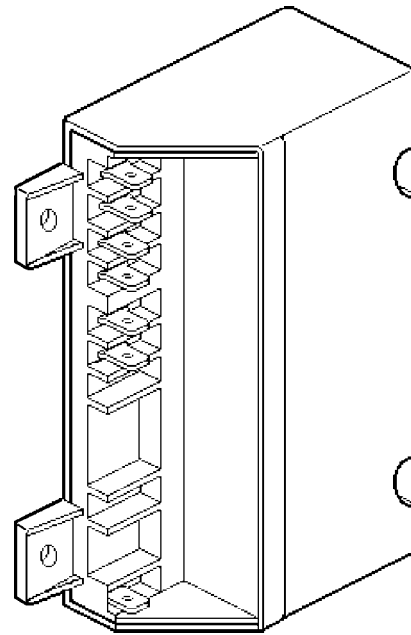

Ignition Module Electronic Safety

Fig.#8929.1

TANKSTAT TEMPERATURE CONTROL

This is a bulb immersion type device that will regulate the water temperature in the storage tank. When the water temperature rises to the set point, the switch opens and shuts off the main burners. As the water cools down, the switch closes and turns on the main burners again to maintain the desired water temperature.

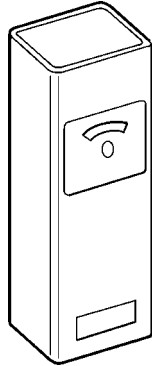

Fig. #8643

Temperature Control

HIGH LIMIT

The high limit is also a bulb immersion type device that limits the water temperature in the heater outlet. It will shut off the main burners when the heater outlet water temperature exceeds the high limit setting, and cycles on again when the water temperature drops to the set point, less the differential.

Models are equipped with manual reset high limit on all models except 136. Model 136 is equipped with an automatic reset high limit.

HIGH LIMIT (Manual Reset)

The manual reset high limit is similar to the automatic reset high limit, except the reset button on the front of the case must be pushed in to allow the main burners to operate again after a high limit shutdown.

Models are equipped with manual reset high limit. The temperature setting is usually set 30° to 40°F above the operating temperature.

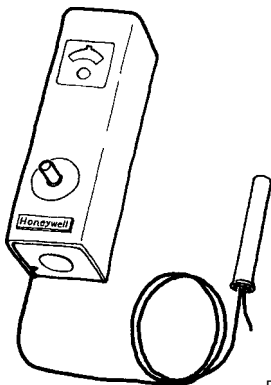

Fig. #9314

Manual Reset High Limit

FLOW SWITCH

Dual purpose control shuts off heater in case of pump failure or low water flow condition.

Factory mounted on all boilers except 136 and wired in series with main gas valve.

NOTE: Flow switch will not operate if flow is less than 12 GPM.

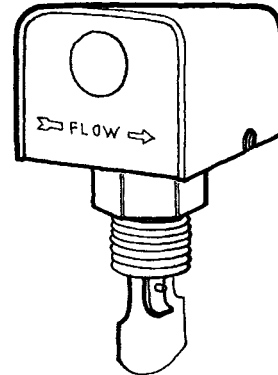

Fig. #9317

Flow Switch

100% PILOT SAFETY (IID Units)

All heaters employ electronic devices, which close the main gas valve within 8/10 of a second whenever the pilot flame is interrupted. Pilot flame is automatically lit when the device is powered. Unit performs its own safety check and opens the main valve only after the pilot is proven to be lit.

ELECTRICAL

Heater electrical characteristics are

Primary: 115 volt 60 Hz 1 phase.

Secondary: Control Circuit: 24 volts.

CAUTION: All wires prior to disconnection when servicing controls. Wiring errors can cause improper and dangerous operation. Verify proper operation after servicing.

DANGER - SHOCK HAZARD

make sure electrical power to the heater is disconnected to avoid potential serious injury or damage to components.

The heater is normally wired for 120 Volts. The voltage is indicated on the tie-in leads. Consult the wiring diagram shipped with the boiler in the instruction packet. The "TH" leads are for the remote tank control connections 24 Volts are supplied to this connection through the heater transformer. DO NOT attach line voltage to the "TH" leads on sized 133-1826. Before starting heater check to insure proper voltage to boiler and pump.

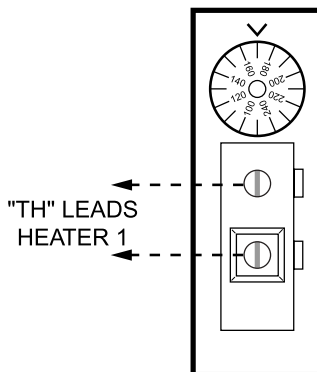

BREAK THE WIRE NUT AT THE HEATER "TH" CONNECTIONS AND ATTACH TO THE SINGLE TANKSTAT AS SHOWN IN THE DIAGRAM ABOVE.

Single Stage Tankstat

HEATER DPST TANKSTAT CONTROL WIRING

Heater must be electrically grounded in accordance with National Electrical Code ANSI/NFPA No. 70.

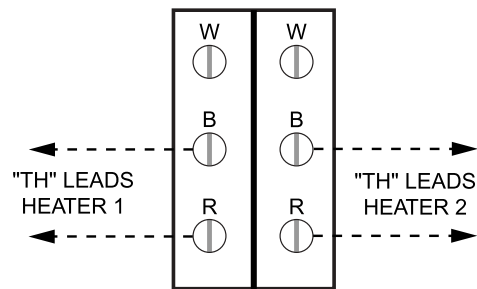

BREAK THE WIRE NUT AT THE HEATER "TH" CONNECTIONS AND ATTACH TO THE DUAL TANKSTAT AS SHOWN IN THE DIAGRAM ABOVE.

Single Stage Tankstat

NOTES:

1. Field Installed ground to inside of junction box.
2. If any of the original wire as supplied with the heater must be replaced, it must be replaced with 105°C wire or its equivalent.

WARNING:

Before starting check to insure proper voltage is supplied to heater and pump.

Heater must be electrically grounded in accordance with the National Electrical Code ANSI/NFPA No 70 latest edition.

Use wiring diagram supplied with the heater.

START-UP

1. Fill system with water, flush, to remove particles and other foreign objects that can cause pump damage.
2. Check electric supply characteristics
 - a. Voltage to heater: 115 volts 60 Hz. 1 phase
15 amp circuit breaker.
 - b. Voltage to pump:
3. Set operating and limit controls.

ON-OFF OPERATION

Set storage tank tankstat to desired temperature. This is the operating control. See Operation sequence, page 22.

General Safety Precautions

To meet commercial water use needs, the thermostat on this water heater is adjustable up to 210°F. However, water temperatures over 125°F. can cause severe burns instantly or death from scalds. This is the preferred starting point for setting the control for supplying general purpose hot water.

Safety and energy conservation are factors to be considered when setting the water temperature on the thermostat. The most energy efficient operation will result when the temperature setting is the lowest that satisfies the needs consistent with the application.

The following chart details the relationship of water temperature and time with regard to scald injury and may be used as a guide in determining the safest water temperature for your applications.

Temperature	Time to Produce Serious Burn
120°F.	More than 5 minutes
125°F.	1-1/2 to 2 minutes
130°F.	About 30 seconds
135°F.	About 10 Seconds
140°F.	Less than 5 seconds
145°F.	Less than 3 seconds
150°F.	About 1-1/2 seconds
155°F.	About 1 second

Table courtesy of Shiners Burn Institute

TIME/TEMPERATURE RELATIONSHIPS IN SCALDS

The temperature of the water in the water heater can be regulated by setting the temperature dial on front of the thermostat. To comply with safety regulations the thermostat was set at its lowest setting before the water heater was shipped from the factory. The illustration below illustrates the thermostat and how to adjust the water temperature.

DANGER

Water temperature over 125°F can cause severe burns instantly or death from scalds.

Children, disabled and elderly are at highest risk of being scalded.

See instruction manual before setting temperature at water heater.

Feel water before bathing or showering.

Temperature limiting valves are available, see manual.

To adjust the water temperature, insert a small straight screwdriver into slotted screw in hole in front of thermostat and turn wheel to desired setting. Thermostat is adjustable up to 210°F.

CAUTION!! - Hotter water increases the risk of SCALDING!

DANGER

There is a Hot Water SCALD Potential if the thermostat is set too high.

NOTE: When this water heater is supplying general purpose hot water requirements for use by individuals, a thermostatically controlled mixing valve for reducing point of use water temperature is recommended to reduce the risk of scald injury. Contact a licensed plumber or the local plumbing authority for further information.

Maximum water temperatures occur just after burner has shut off. To find hot water temperature being delivered, turn on a hot water faucet and place a thermometer in the hot water stream and read the thermometer.





LIGHTING INSTRUCTIONS FOR HEATERS WITH ELECTRONIC IGNITION (IID)
For Models with Manual Gas Valves 512, 627, 726



FOR YOUR SAFETY READ BEFORE OPERATING

WARNING: If you do not follow these instructions exactly, a fire or explosion may result causing property damage, personal injury or loss of life.

- A. This appliance is equipped with an ignition device which automatically lights the pilot. Do not try to light the pilot by hand.
- B. BEFORE OPERATING Smell all around the appliance area for gas. Be sure to smell next to the floor because some gas is heavier than air and will settle on the floor.
WHAT TO DO IF YOU SMELL GAS
 - * Do not try to light any appliance.
 - * Do not touch any electric switch: do not use any phone in your building.
 - * Immediately call your gas supplier from your neighbor's phone. Follow the gas supplier's instructions.
- * If you cannot reach your gas supplier, call the fire department.
- C. Use only your hand to push in or turn the gas control knob. Never use tools. If the knob will not push in or turn by hand, do not try to repair it, call a qualified service technician. Force or attempted repair may result in a fire or explosion.
- D. Do not use this appliance if any part has been under water. Immediately call a qualified service technician to inspect the appliance and to replace any part of the control system and any gas control which has been under water.

OPERATING INSTRUCTIONS

1. STOP! Read the safety information above on this label.
2. Set the thermostat on the lowest setting.
3. Turn off all electric power to the appliance.
4. This appliance is equipped with an ignition device which automatically lights the pilot. Do not try to light the pilot by hand.
5. Remove boiler door panel.
6. For Robertshaw gas valve: Turn gas control knob clockwise  to "OFF".
For Honeywell Gas Valve: Turn gas control knob clockwise  to "OFF". Make sure knob rest against stop.
- For Honeywell Gas Valve:
Push in gas control knob slightly and turn clockwise to "OFF". Knob cannot be turned to  "OFF" unless knob is pushed in slightly. Do not force.
7. Wait five (5) minutes to clear out any gas. Then smell for gas, including near the floor. If you smell gas, STOP! Follow "B" in the safety information previously stated. If you do not smell gas, go to the next step.
8. **For Robertshaw Gas Valve:** Turn gas control knob counter clockwise  to "ON".

For Honeywell Gas Valve: Turn gas control knob counter clockwise  from "OFF" until it stops. Push in gas control knob and continue rotating counter clockwise  to "ON" position. Make sure knob rest against stop.

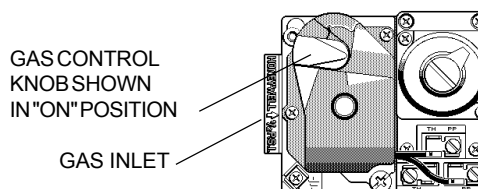

Fig. #8082

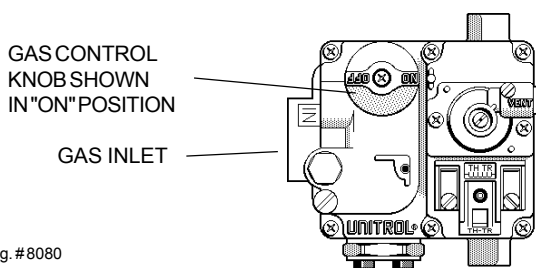





Fig. #8080

9. Replace boiler door panel.
10. Turn on all electric power to the appliance.
11. Set thermostat to desired setting.
12. If the appliance will not operate, follow the instructions "To Turn Off Gas To Appliance" and call your service technician or gas supplier.

TO TURN OFF GAS TO APPLIANCE

1. Set the thermostat to the lowest setting.
2. Turn off all the electric power to the appliance if service is to be performed.
3. Remove door panel.
4. **For Robertshaw Gas Valve:** Turn gas control knob clockwise  to "OFF".
For Honeywell Gas Valve: Turn gas control knob clockwise  to "OFF". Make sure knob rest against stop.
For Honeywell Gas Valve: Push in gas control knob slightly and turn clockwise  to "OFF".
5. Replace heater door panel.

**LIGHTING INSTRUCTIONS FOR HEATERS WITH
ELECTRONIC IGNITION (IID)
FOR MODELS WITH AUTOMATIC GAS VALVES
726-1826**

1. Close all gas valves. Turn off electric power supply. Wait five (5) minutes.
2. Open manual pilot valve. Turn on electric power. Pilot is automatically lighted.
3. Open main gas valve.
4. Set temperature controls to desired temperature.

TO SHUT DOWN

Close all manual gas valves. Turn off electric power.

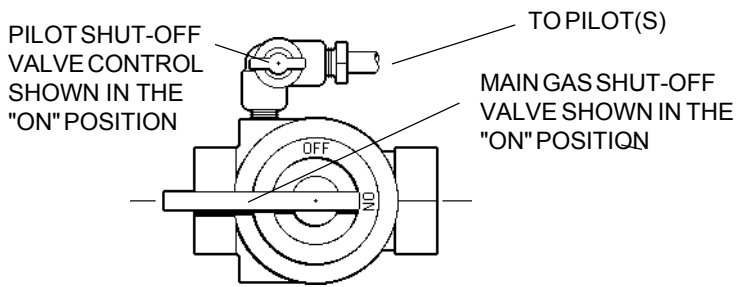

INSPECTION AND MAINTENANCE PROCEDURES

It is a good practice to make a periodic inspection of the heater. It is recommended that the home owner or user checks the heater after the first and third month of operation, and then on an annual basis, or more often if desired. It is also recommended to have a qualified service agency check the heater before each heating season, or at anytime there may be an indication of a problem.

1. Keep heater area free from combustibles and flammable liquids.
2. Be certain that All combustion and ventilation air openings are free and clear of all obstructions. Screens, covering same, must be clean.

Monthly:

1. Make visual inspection of burner flames.

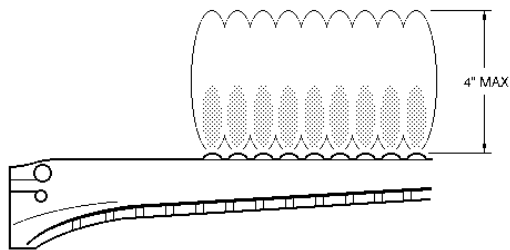

Fig. #8144

- a. Flame should be blue with light yellow tips.
 - b. Yellow flame indicates clogged air openings.
 - c. Lifting of flame indicated high gas pressure. Check using manometer at 1/8 in. NPT tapping located between the gas valve and the burners. Pressure should be 3.7 in. W.C.
2. Inspect and operate all controls and gas valves.
 3. Visually inspect system for water leaks

Six Months:

1. Heat Exchanger Surfaces.
 - a. Shut off electric and gas supply to heater.
 - b. Examine external surfaces
2. Preliminary examination maybe done by using a mirror and a light in the burner area.
3. Remove venting, heater jacket top, flue collector and heat exchanger baffles. Remove inspection baffles.
 - c. If surfaces are sooted or foreign material is lodged in fins, cleaning is required.

To clean:

- A. Remove burner tray.
 - Disconnect gas control valves and pilot valves by breaking at unions.
 - Disconnect wiring from gas valves.
 - Remove burner tray retention screws.
 - Slide tray from heater carefully to avoid disturbing or damaging IID.
- B. Remove tube bundle.
 - Disconnect inlet-outlet header by removing flange nuts and retaining bolts.
 - Slide tube bundle away from inlet-outlet header, taking care to avoid damage to refractory and sheetmetal.
 - Washdown external surfaces of tube bundle.
 - Inspect interior surfaces of tubes. Clean deposits over 1/16" thickness.
 - Clean tubes using tube cleaning kit.
- C. Ream tubes by using auger bit.
- D. Complete cleaning by wire brushing to remove all debris.
- E. Immerse tube bundle in non-inhibited descale solvent.

NOTE: DO NOT wire brush external surfaces. Steam cleaning is a recommended procedure.

- F. Replace tube bundle using the reverse of the above procedures.
- G. Before replacing burner tray clean burners.

4. Flow switch should be removed and checked.
5. Low water cutout, if provided, should be removed and checked.

DANGER: Keep heater area clear and free from combustibles and flammable materials. Do not obstruct the flow of combustion and ventilating air into the heater enclosure. Failure to observe these safety precautions can cause fire, explosion, or asphyxiation.

1. Burner Inspection

Clean the main burners and air louvers of dust, lint and debris. With burner in operation, make a visual check of the burner flame and the pilot flame (when equipped). Yellow flames indicate some restriction of combustion air openings. A bright orange, luminous flame is not normal and can cause sooting under prolonged operation. Should this condition be observed, contact immediately a qualified service agency to correct the problem.

2. Venting System Inspection

Visually inspect the venting system. Make sure the vent connections are secure and have not become disengaged. Look for any indication of corrosion, or carbon (soot) streaks which could cause leakage of products of combustion into the living space. Inspect the vent terminal outside the building. Make sure it is not damaged to cause blockage or restriction of the flue gas. Observe for any indication of soot. The presence of soot accumulation in the vent terminal would indicate an abnormal operating condition. This should be investigated and corrected by a qualified service agency.

3. Circulator (Water Pump) Inspection

The circulator is permanently lubricated and thus, will not require any lubrication. Inspect for evidence of water leakage. This should be corrected to prevent any possible damage to electrical components of the boiler.

CAUTION: In case of a prolonged power failure during freezing weather conditions, heater and piping system must be drained completely to avoid possible damage to the system.

To prevent the potential freezing damage to the system, it is recommended that the following system shut down procedure be performed.

SYSTEM SHUT DOWN PROCEDURE

1. Set the thermostat to "OFF" or the lowest setting.
2. Turn off all electric switches to the heater.
3. Turn off all gas valves supplying gas to the heater. Refer to operating instruction label on the heater.
4. Shut off the water supply to the heater piping system loop.
5. Open drain valve on the heater to remove water from the heater and the piping circuits.

NOTE: It may be necessary to open the purge valves and/or manual air vents to facilitate complete drainage of water from the heating system.

4. Service Assistance

If service is required on the heater, contact your local service agency. It is important and very often will save time if you state the model number, serial number and type of gas used. This information will be found on the nameplate of the heater.

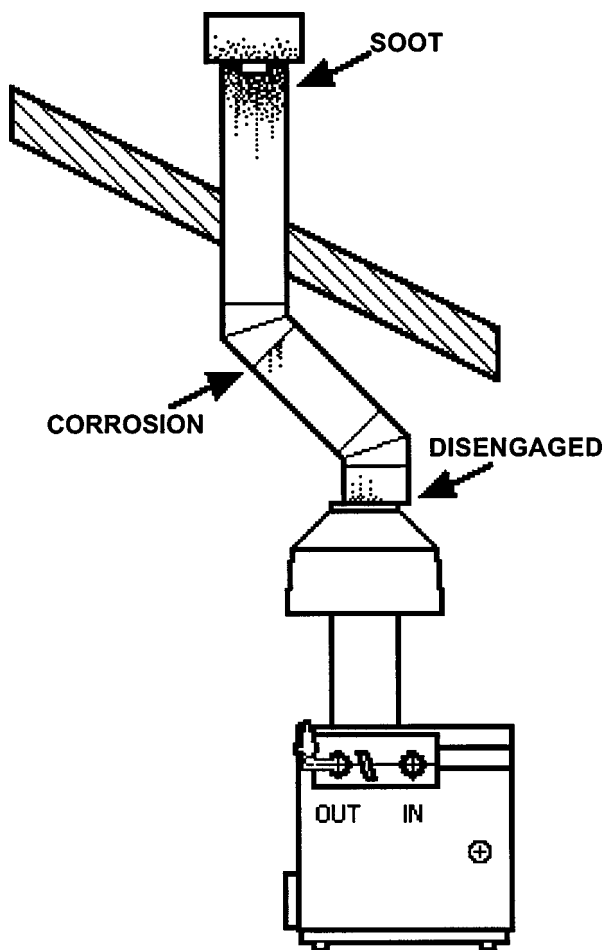

Fig. #8204.1

TROUBLE SHOOTING

PROBLEM	CAUSE	SOLUTION
When thermostat is turned on nothing happens.	IID Pilot is not lit.....	Check pilot gas line.
	No power to the heater.....	Check the circuit breaker, outdoor controller, etc., upstream of heater.
	Bad Trans- former.....	If power to Leads L1 and L2 of transformer, but no power on 24V side, replace.
	Inoperative thermostat.....	Jumper thermostat , replace with new if heater fires.
	Inoperative toggle switch.....	If power to toggle switch, but not through switch, replace.
	Inoperative relay.....	If power to relay, but not operating, replace.
Thermostat in on position causes relay and pump to operate, but heater does not fire.	"A" valve closed.....	Open "A" valve.
	Plugged bleed line.....	Loosen bleed line and clean.
	Flow switch open.....	Low flow. Bleed air from the system. Adjust bypass valve to allow proper flow to activate the flow switch. If flow problem persists due to system design, primary-secondary pumping should be considered.
	Broken pump cou- pler.....	Replace coupler. Inspect bearing assembly, and if frozen lubricate or replace.
	Shut down on low water cutoff, caused by air.....	Bleed air reset button.
	Gas valve defective.....	Check for power to gas valve. If valve has power but will not open, replace the valve.
Continuous shut down of low water cut off.	Low water due to leaking.....	Inspect for leakage and repair.
	Air in system.....	Inspect for leakage and repair. Install an automatic air vent in top of low water cutoff.

TROUBLE SHOOTING

Problem	Possible Cause	Action
1. Heater will not operate:	Electrical:	
	• Main power	Check circuit breaker, fuses, etc. Power at boiler control switch should be 115 volts.
	• Manual reset switch.	Check all controls. If reset is tripped determine reason and correct.
	• Operating controller.	Check power to all controls with voltmeter. Adjust to desired operating temperatures.
	• Controller in-operative.	Remove sensor. Check for immersion or sensing.
	• Flow Switch	Replace if faulty. Check pump for operation.
	Mechanical:	
	• Gas Line	Open shutoff cock(s)
	• Plugged bleedline on pressure regulator, gas valves, etc.	Loosen bleed line and clean.
	• Broken pump coupler.	Check reason for failure. Inspect bearing assembly, shaft and impeller. Replace coupling.
2. Pilot burner will not light	• Gas valve will not open:	Check bleed line. Clean. Check solenoid. Replace if defective.
	1. Diaphragm type.	
	2. Motorized type	Check auxiliary switches. a. Auxiliary switch; b. Valve closed switch. Power should be 115 volts.
	Note: Actuator is not field repairable. If problem is other than switch(es) replace.	
	3. Combination type	Check controller.
	Intermittent Ignition Module (IID)	Check power to 25 VAC input terminal
	1. If 25 VAC:	
	- Check for 1/8" spark @ pilot.	
	a. Spark ok:	
	• Check gas supply.	
• Burner orifice.		
• Dampness @ electrode or high tension wire.		
• Check for 25 VAC @ PV; MV/PV terminals.		
1. Voltage @ 25 VAC		
- Replace pilot valve.		
2. Voltage not @ 25 VAC		
- Replace module.		
2. No 25 VAC @ input terminal.		
- Check transformer output.		
a. 25 VAC		
• Check limit circuit.		
b. No 25 VAC		
• Replace transformer.		

Electrical continued

- | | | |
|-------------------|--|--|
| 3. Pilot lights - | Main burner cycles.
Intermittent Ignition Module <ul style="list-style-type: none">• Poor ground connection | Check ground connection.
Install or replace.
Check for spark |
| 4. Pilot lights - | Main burners do not light. | <ol style="list-style-type: none">1. Spark stays on while pilot is on.<ul style="list-style-type: none">• Check for loose ignition wire.• Check for poor ground.• Check flame coverage of both spark and grounded electrodes.• If okay replace ignition module2. Spark goes out and pilot stays on:<ul style="list-style-type: none">• Check voltage at MV; MV/PV terminals.- Voltage @ 24 VAC - replace main gas valve.- Voltage not at 24 VAC - replace module. <p>Voltage should read 24 VAC.
If valve does not open:
1st operator - replace valve
2nd operator- replace operator assembly.</p> |
| | 3. Mechanical Modulating Valve. | Check dial setting on valve and set to meet requirements.
Unit keeps cycling on electrical limits - adjust temperature setting on valve. |
| | 4. Failure to pump. | Pump not primed.
Pump rotation wrong direction. <ul style="list-style-type: none">• Check motor leads- reverse to obtain proper rotation. Speed too low- <ul style="list-style-type: none">• Check for proper voltage at motor. Total head too high. |
| | 5. Pump capacity insufficient. | Check for <ul style="list-style-type: none">• Air leaks in suction line.• Clogged impeller.• Strainer clogged.• Excessive suction lift.• Insufficient positive suction head. Total head greater than design.
Worn impeller. |
| | 6. Rapid coupling wear. | Misaligned or bent shaft,
Sagging motor mounts. |
| | 7. Pump loses prime. | Check for air leaks.
Check water seal in stuffing box.
Check suction lift and pump design curves. |
| | 8. Overload. | Check head on pump if too low
throttle discharge. |
| | 9. Mechanical noise. | Check alignment. Correct if found.
Check for vapor binding and reduce temperature to meet design.
Check shaft and bearings.
Check piping for correct alignment and support. |

C. Trouble shooting for S8600 control. Refer to the following chart for future servicing or the ignition control.

WARNING HIGH VOLTAGE
For qualified Technicians ONLY

NOTE: Some heaters may be equipped with an ignition module that shuts off pilot gas if pilot fails to light. To reset, interrupt power to heater.

**Intermittent Pilot System
TROUBLESHOOTING HONEYWELL S8600**

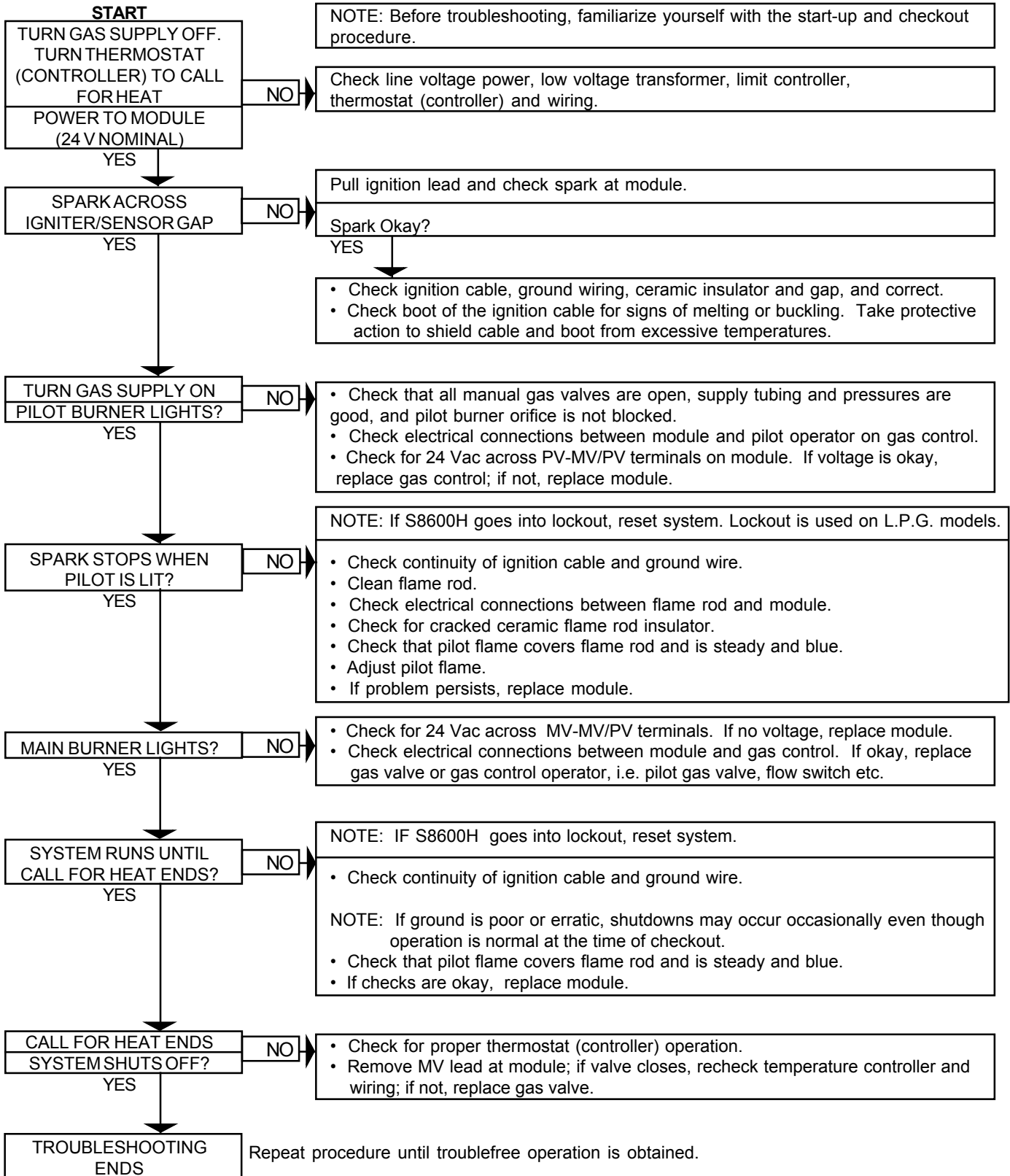

WIRING DIAGRAM KEY

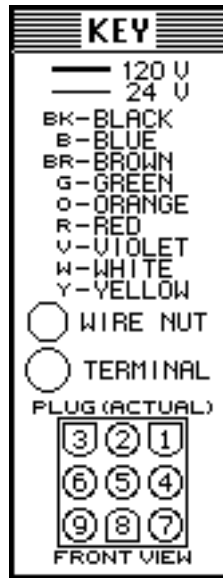

WIRING DIAGRAMS

WIRING DIAGRAM - MODELS 136 -264 WITH ENERGY PUMP SAVING CONTROL

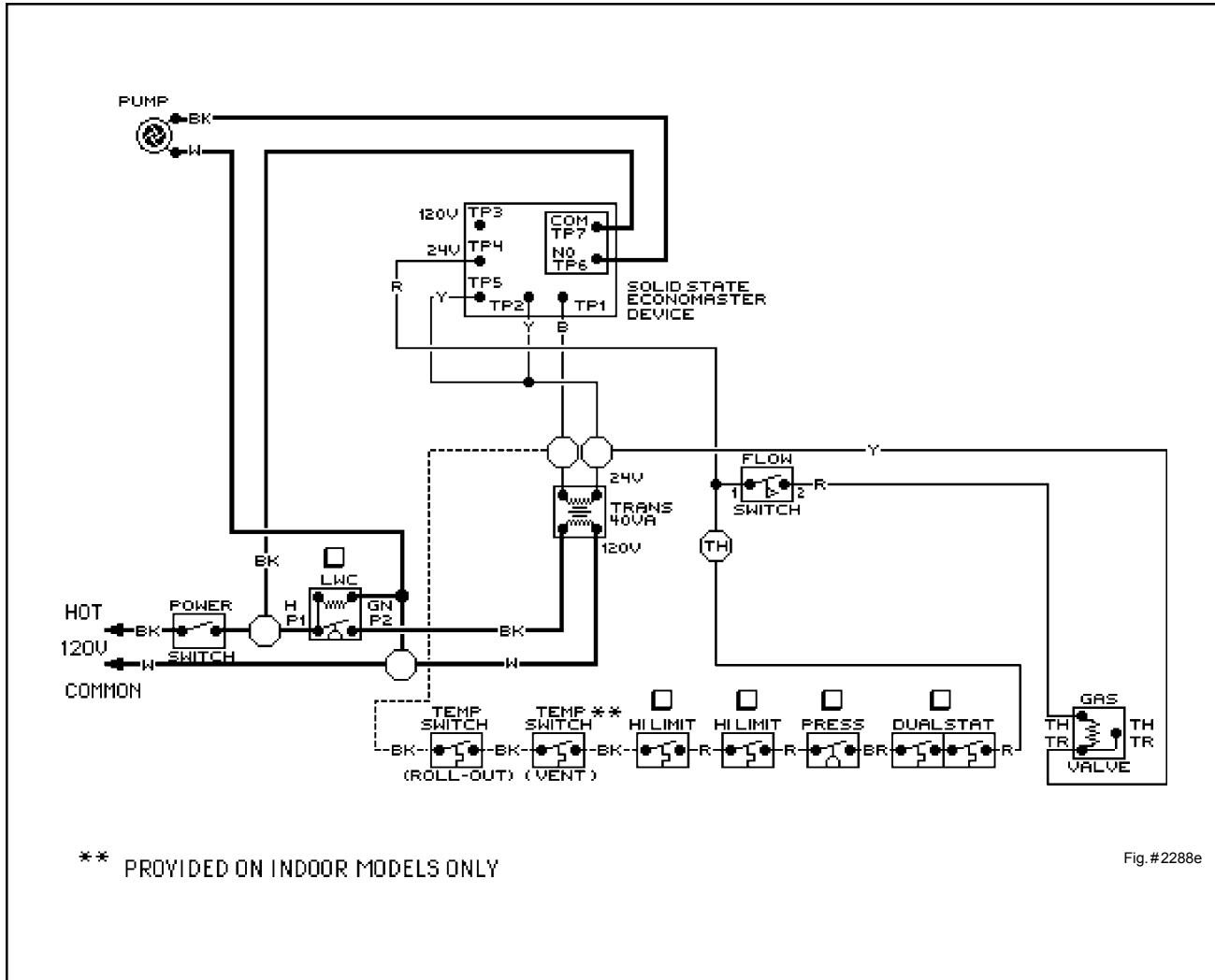

WIRING DIAGRAM - MODELS 331 - 399

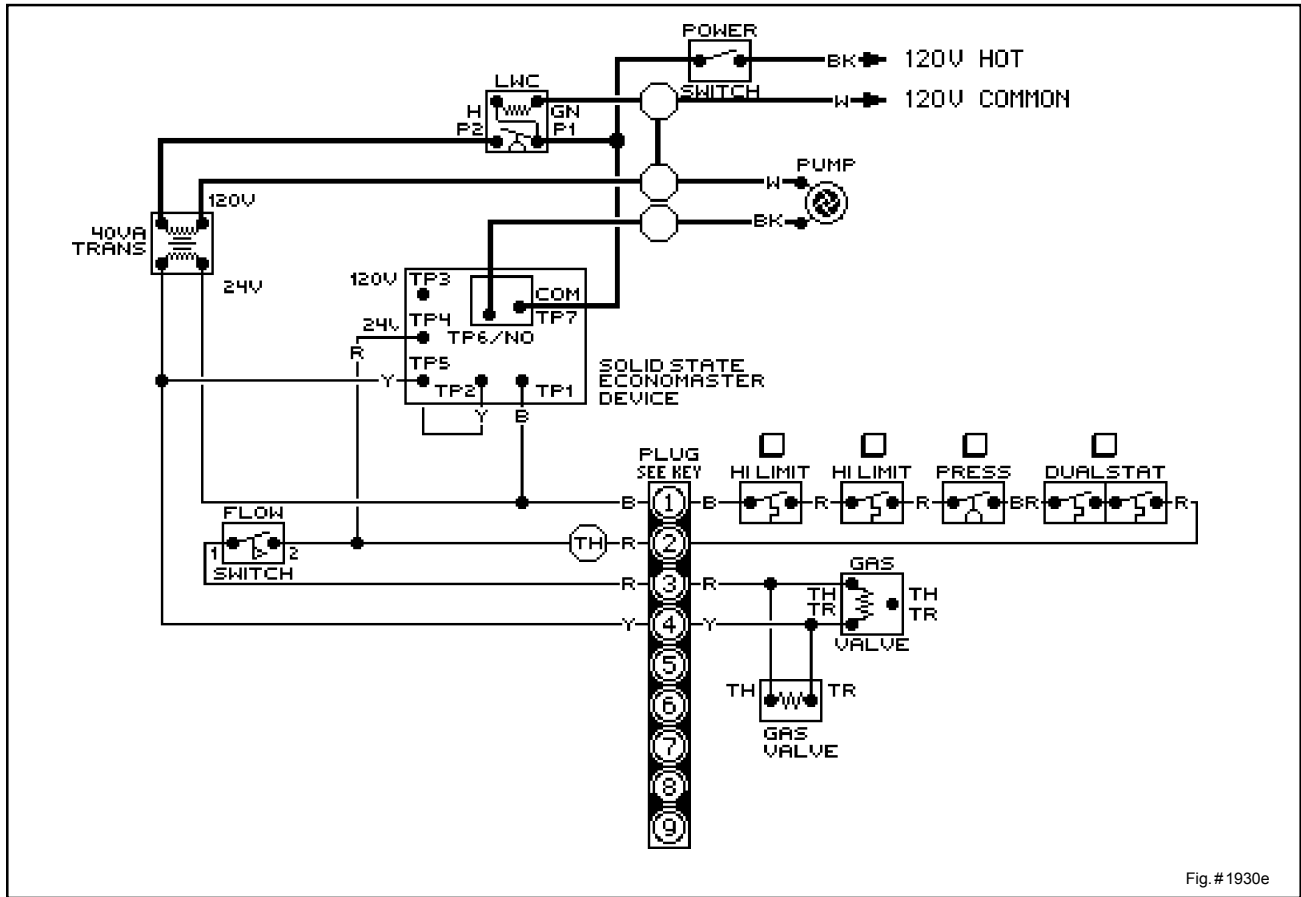

Fig.#1930e

WIRING DIAGRAM MODELS 512 - 627

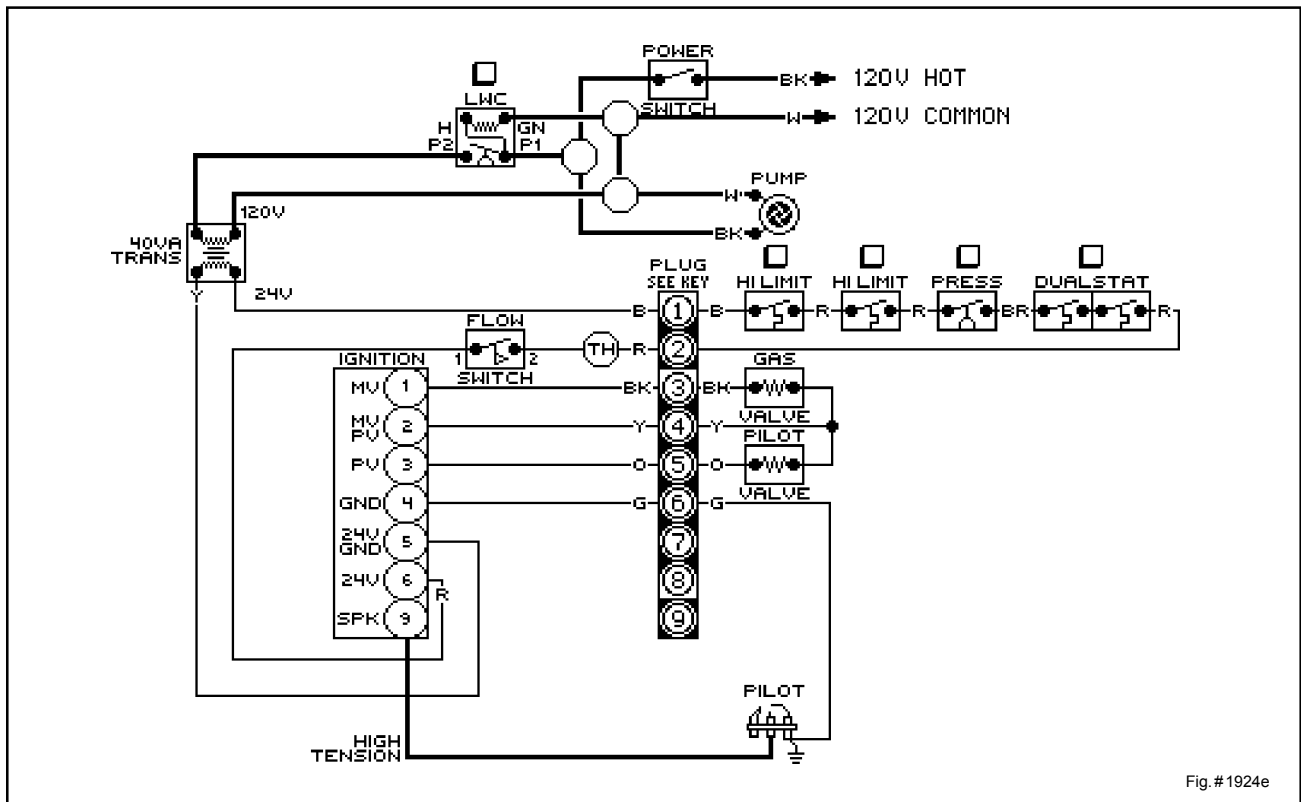

Fig.#1924e

WIRING DIAGRAM MODELS 512-726

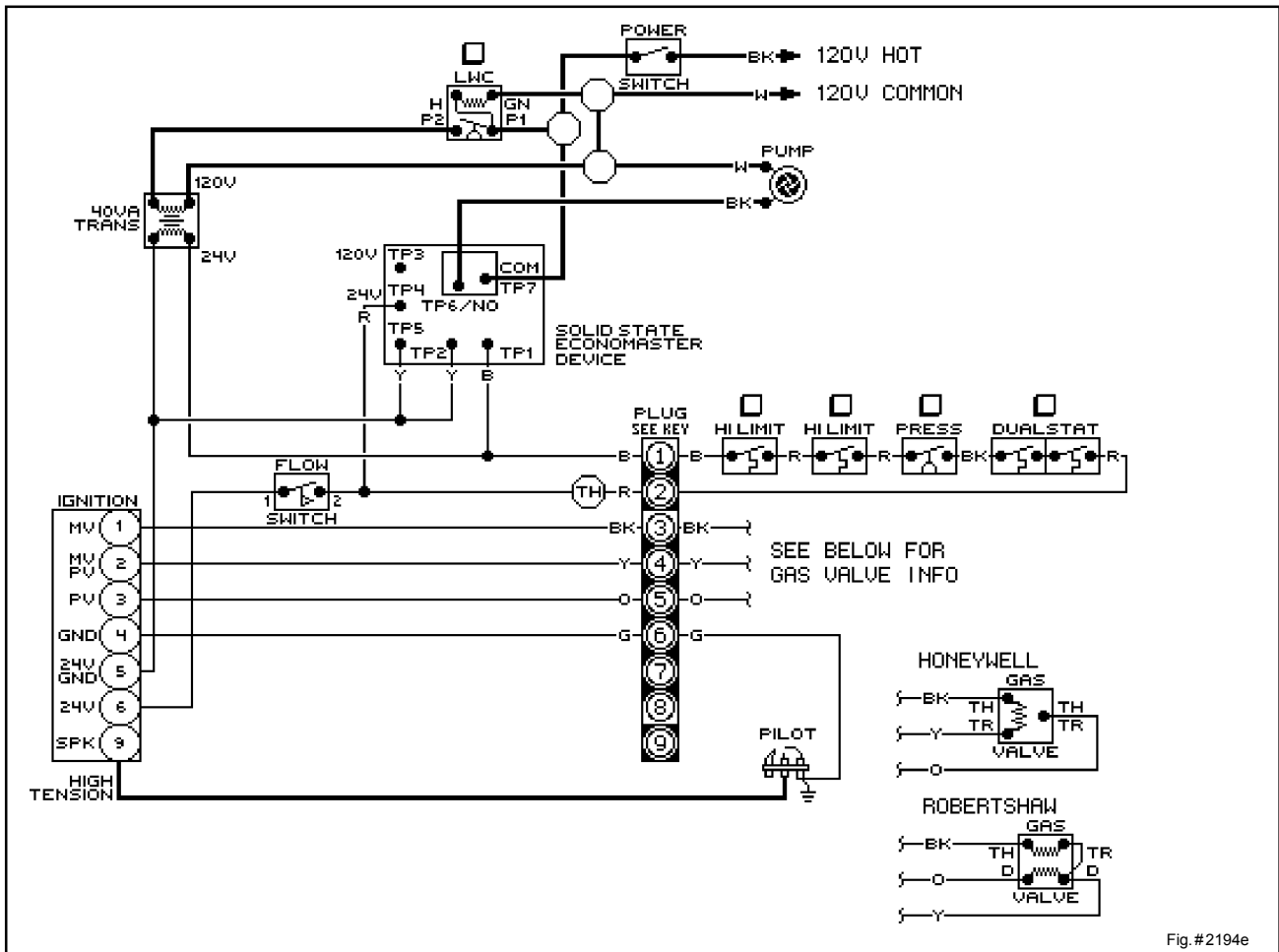

Fig. #2194e

WIRING DIAGRAM MODELS 726 - 825

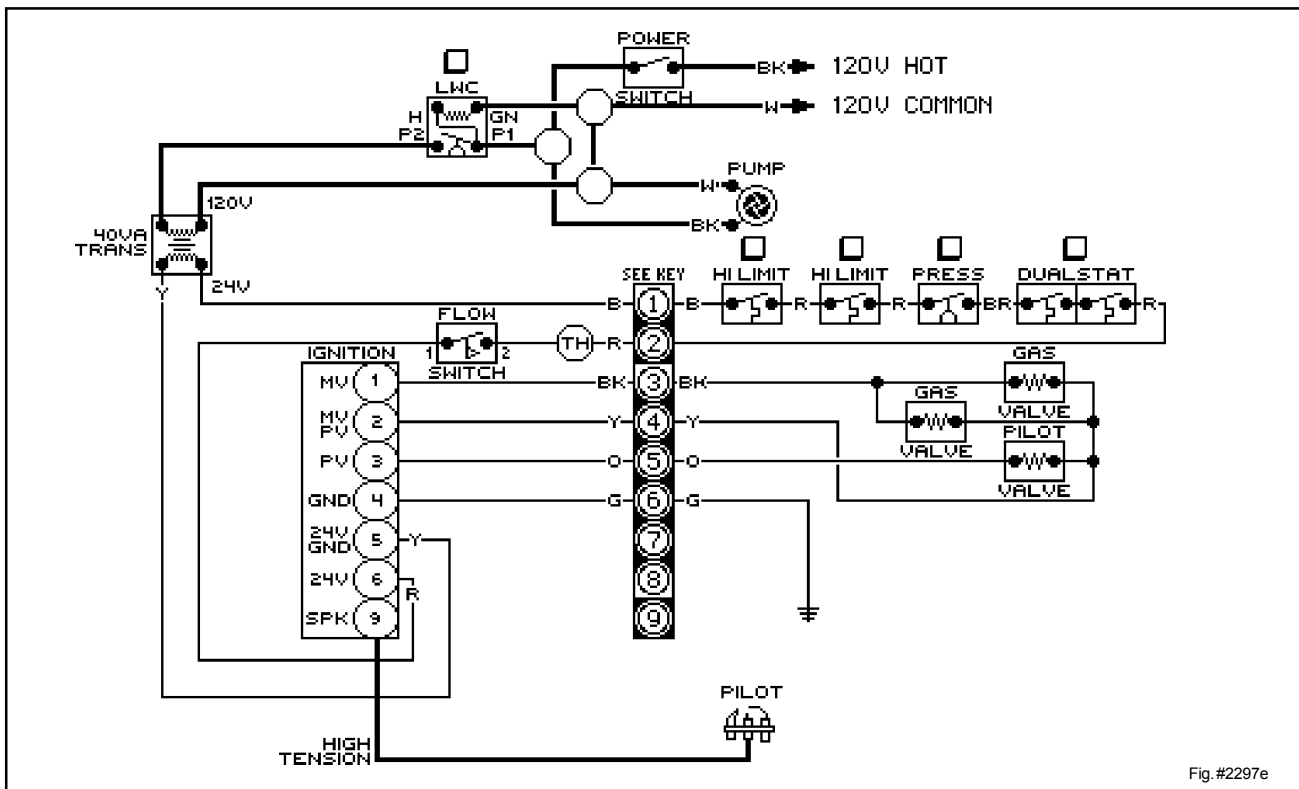
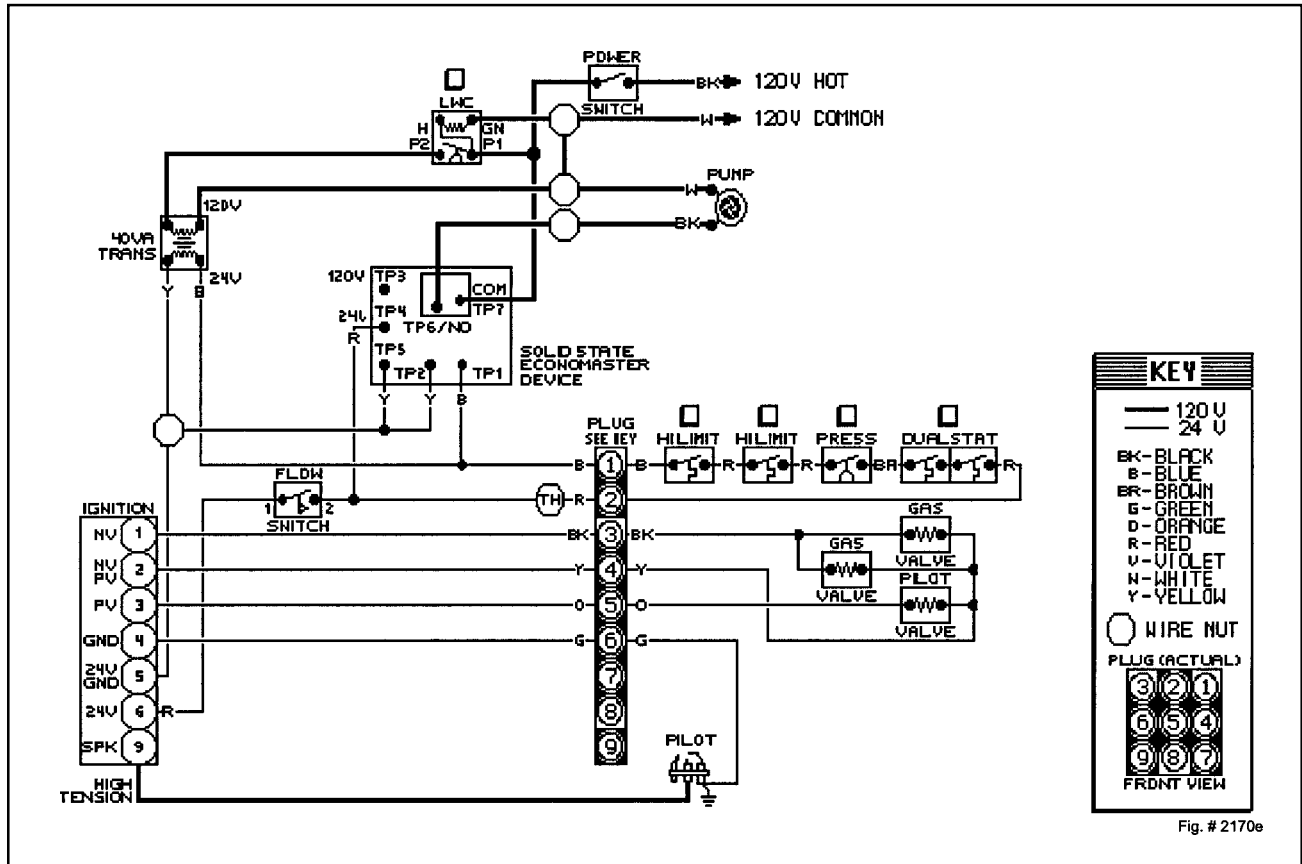
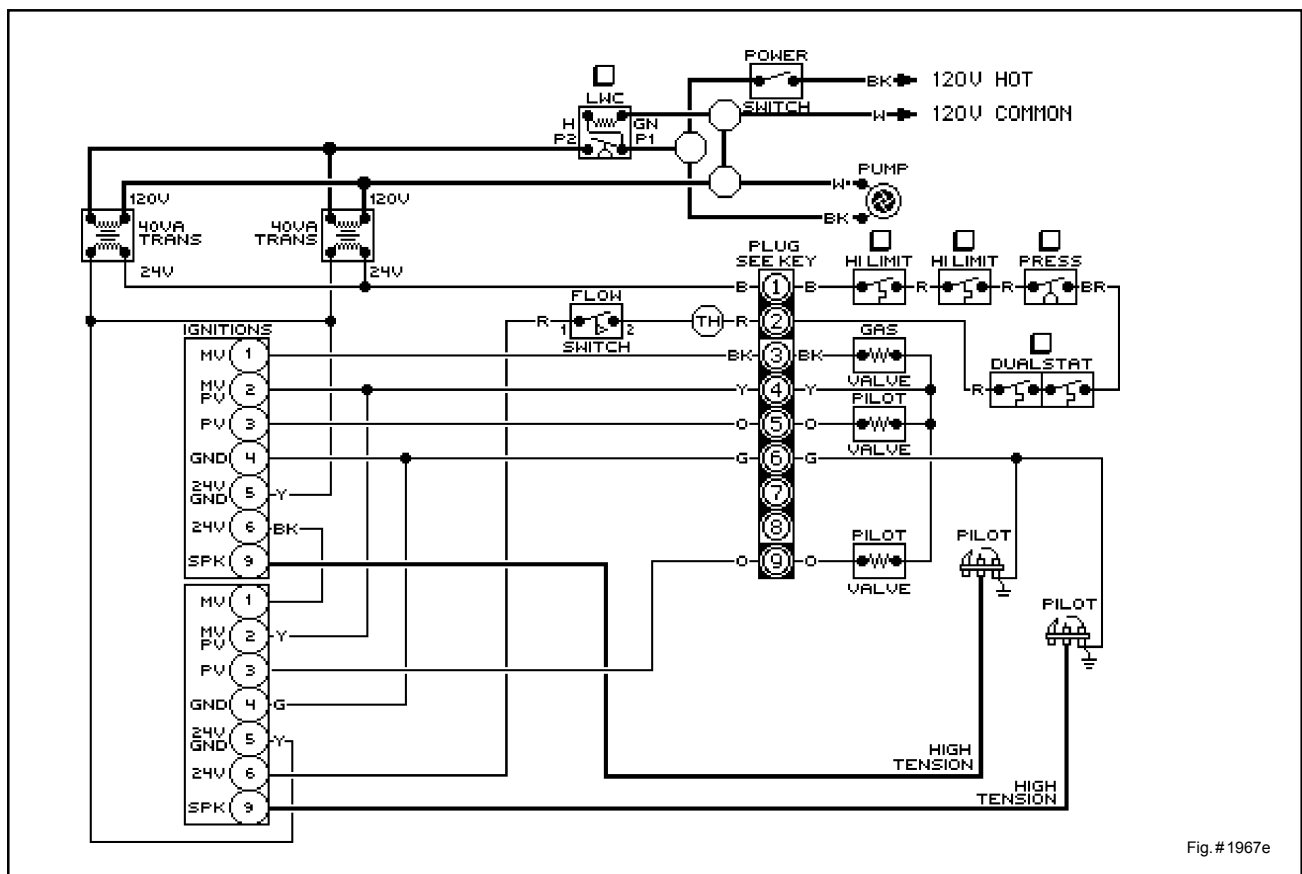

Fig. #2297e

WIRING DIAGRAM MODEL 825 - 1826



WIRING DIAGRAM MODELS 962 - 1826



REPLACEMENT PARTS LISTS

MODEL 136 GB ONLY

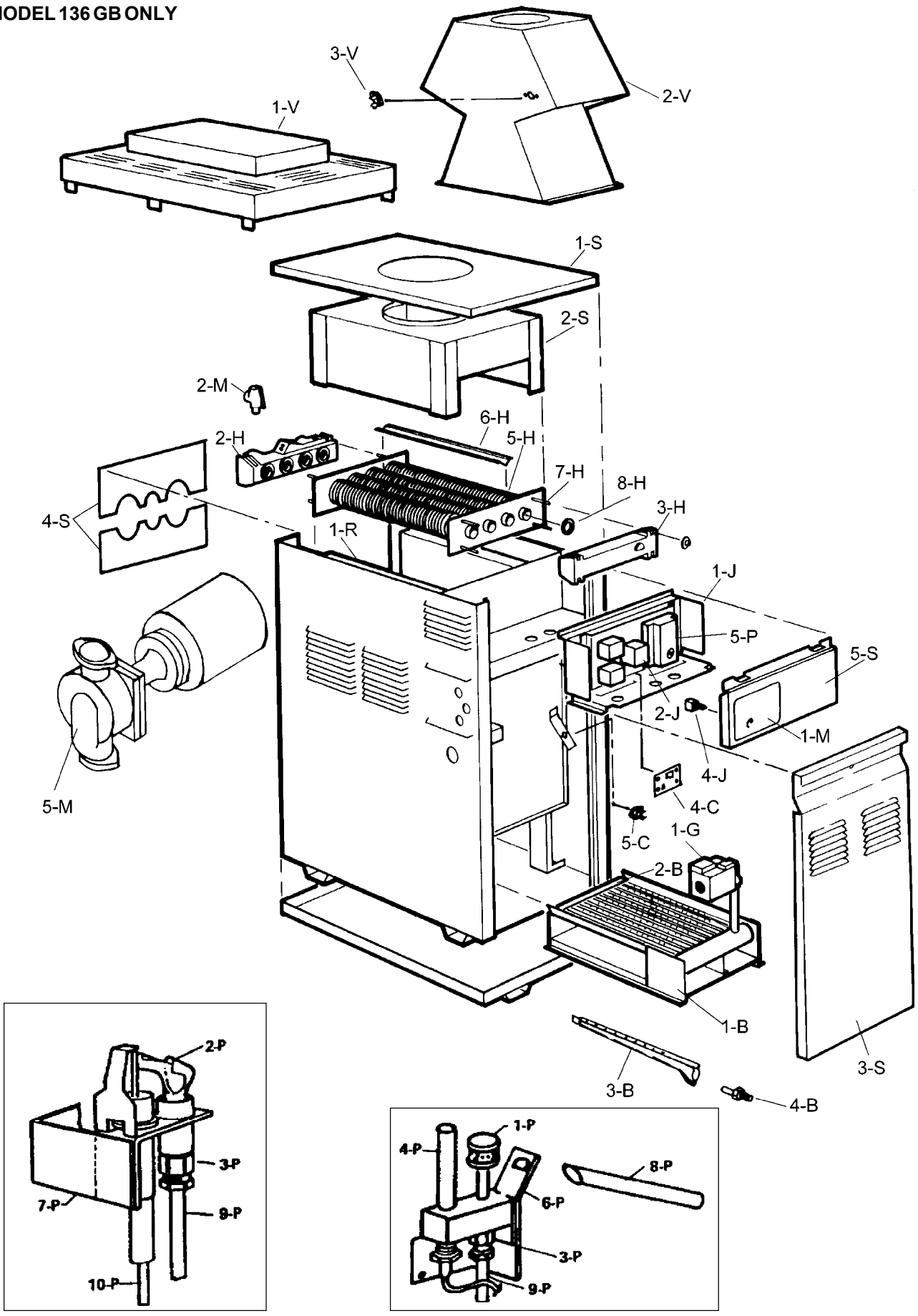

MODEL 136 GB ONLY

CALL OUT	DESCRIPTION	136 GB
B BURNER TRAY		
1-B	Burner Tray w/Burners (Sea Level)*	001989F
	Burner Tray w/o Burners (Sea Level)*	001990F
2-B	Burner Hold Down	001991F
3-B	Burner	301210/10
4-B	Burner Orifice Nat. (Sea Level)*	350080F/10
	Burner Orifice Pro. (Sea Level)*	350083F/10
C CONTROLS		
2-C	Manual High Limit	008081F
4-C	Economaster Control	004675F
5-C	Flame Roll-Out Sensor 150°F	006021F
	Flame Roll-Out Sensor 300°F	006035F
G GAS VALVE		
1-G	Combination Valve Nat. 1/2" IID	003900F
H HEAT EXCHANGER		
1-H	Heat Exchanger Assy. (Complete)	001993F
2-H	Inlet/Outlet Header	001995F
3-H	Return Header	001997F
4-H	Tube Bundle	001998F
5-H	Heat Exchange Tube	001999F
6-H	Baffle Kit	001622F
7-H	Carriage Bolt Kit	001623F
	Stud Bolt Kit	007909F
8-H	Header Gasket	800001B/9
9-H	Sensor Well	007211F
10-H	Well Retaining Clip	300203
J J-BOX/CONTROL BOX		
1-J	J-Box IID Natural	002013F
	J-Box IID Porpane w/Lockout	002013F
2-J	Transformer	006533F
3-J	Relay DPST	650277F
	Relay SPDT	008090F
4-J	Toggle Switch	008079F
M MISCELLANEOUS		
1-M	Switch Plate IID	901401
2-M	PRV 125 PSI	008091F
3-M	Delimiting Kit	053868F
4-M	T & P Gauge	007399F
5-M	Pump CIBF	005571
	Pump BRASS	005572
P PILOT		
2-P	Pilot Nat. IID	002003F
	Pilot Pro. IID	002003F
3-P	Pilot Orifice Nat. IID	600811
	Pilot Orifice Pro IID	601218
5-P	Ignition Control	004817B
	Ignition Control Lockout	004818B
7-P	Pilot Mounting Bracket IID	006055F
9-P	Pilot Tube	004878F
10-P	Hi Tension Wire	006088B
	Hi Tension Wire W/pilot Electode	007864F
R REFRACTORY		
1-R	Refractory Kit	000992F
2-R	Refractory Retainer Kit	002006F
S SHEETMETAL		
1-S	Jacket Top	002007F
2-S	Flue Collector	002008F
3-S	Door Assy.	002010F
4-S	Access Panel Group	001624F
5-S	Control Panel IID	002765F
V VENTING		
1-V	Stackless Top Kit (Outdoor)	003710
2-V	Draft Hood Kit (Indoor)w/o Sensor	003723
	Drafhod Kit (Indoor) w/Sensor	004679
3-V	Flue Gas Spillage Sensor	006021F

*For altitudes above 2000 feet above sea level, consult the factory.

MODELS 181, 264, 331, 399 GB

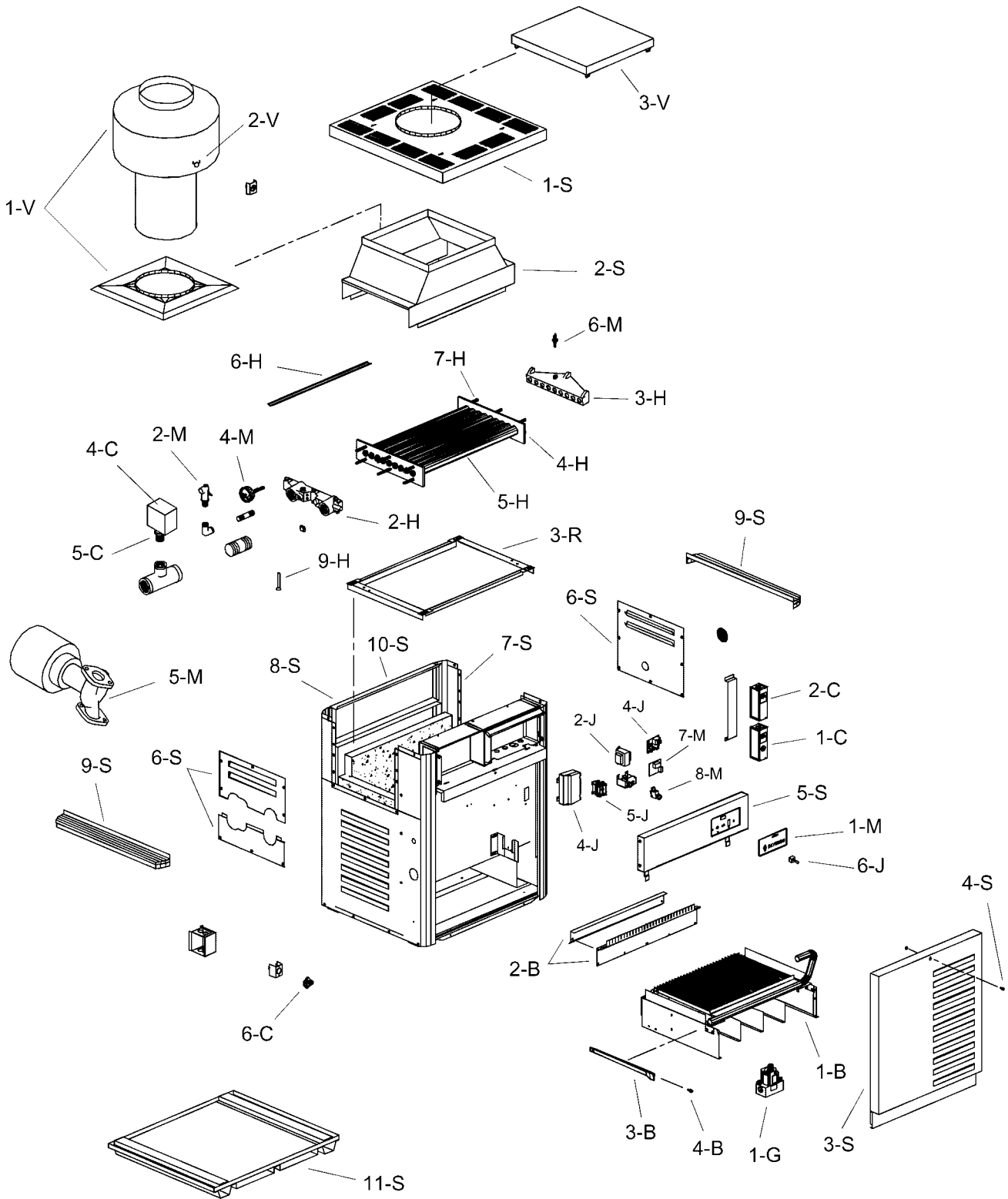

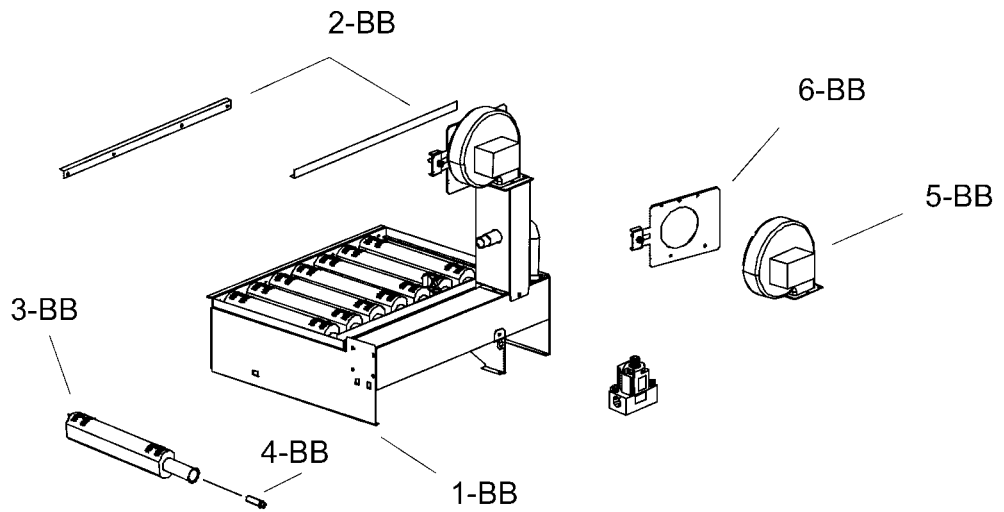

FOR UNITS WITH A LOW NO_x BURNER TRAY

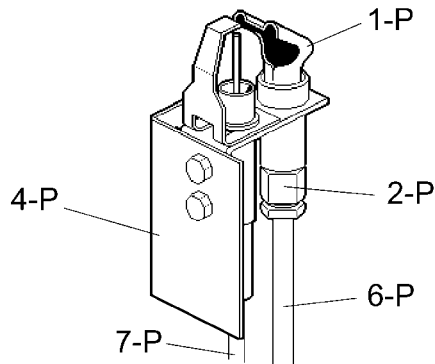

HONEYWELL IID PILOT ASSEMBLY

MODELS 181, 264, 331, 399 GB

CALL OUT	DESCRIPTION	181	264	331	399
B	BURNER TRAY (Atmospheric)				
1-B	Burner Tray w/Burners (Sea Level)*	005213F	005214F	005215F	005216F
	Burner Tray w/o Burner (Sea Level)*	005217F	005218F	005219F	005220F
2-B	Burner Spacer/Hold Down Kit	005237F	005238F	005239F	005240F
3-B	Burner	301210/13	301210/19	301210/24	301210/29
4-B	Burner Orifice Nat. #51 (Sea Level)*	350080F/13	350080F/19	350080F/24	350080F/29
	Burner Orifice Pro. #57 (Sea Level)*	350083F/13	350083F/19	350083F/24	350083F/29
5-B	Burner Tray w/o Manifold and Burners	005265F	005266F	005267F	005268F
BB	BURNER TRAY (Fan Assisted Low Nox)				
1-BB	Burner Tray w/Burners (Sea Level)*	007994F	007995F	007996F	007997F
	Burner Tray w/o Burner (Sea Level)*	007998F	007999F	008000F	008001F
2-BB	Burner Hold Down Kit	008002F	008003F	008004F	008005F
3-BB	Burner	309255/3	309255/5	309255/6	309255/7
4-BB	Burner Orifice Nat. #28 (Sea Level)*	351510/3	351510/5	351510/6	351510/7
5-BB	Blower	008080F	008080F	008080F	008080F
6-BB	Air Shutter	008133F	008134F	008134F	008134F
C	CONTROLS				
1-C	Manual Hi Limit 200 Deg Max.	008081F	008081F	008081F	008081F
2-C	Adj/Auto Hi Limit 200 Deg Max	006445F	006445F	006445F	006445F
3-C	Tankstat (Not Shown)	007148F	007148F	007148F	007148F
4-C	Flow Switch	007142F	007142F	007142F	007142F
5-C	Flow Switch Paddle	004079F	004079F	004079F	004079F
6-C	Flame Roll-Out Sensor	006035F	006035F	N/A	N/A
G	GAS VALVE				
1-G	Valve - Gas On/Off (NAT) Atmospheric	003900F	003900F	003900F	003900F
	Valve - Gas On/Off (PRO) Atmospheric	004306F	004306F	004306F	004306F
	Valve - Gas On/Off (NAT) Fan Assisted Low Nox	007424F	007424F	007424F	007424F
H	HEAT EXCHANGER				
1-H	Heat Exchanger Assy Cast Iron	008006F	008007F	008008F	008009F
	Heat Exchanger Assy Brass	008010F	008011F	008012F	008013F
	Heat Exchanger Assy Cast Iron Cupro Nickel	008014F	008015F	008016F	008017F
	Heat Exchanger Assy Brass Cupro Nickel	008018F	008019F	008020F	008021F
2-H	Inlet/Outlet Header Cast Iron	002040F	002040F	002040F	002040F
	Inlet/Outlet Header Brass	002041F	002041F	002041F	002041F
3-H	Return Header Cast Iron	002042F	002042F	002042F	002042F
	Return Header Brass	002043F	002043F	002043F	002043F
4-H	Tube Bundle	008022F	008023F	008024F	008025F
	Tube Bundle Cupro Nickel	008026F	008027F	008028F	008029F
5-H	Heat Exchange Tube	008030F	008031F	008032F	008033F
	Heat Exchange Tube Cupro Nickel	008034F	008035F	008036F	008037F
6-H	Baffle Kit	008038F	008039F	008040F	008041F
7-H	Stud Bolt Kit	007870F	007870F	007870F	007870F
8-H	Header Gasket	800203B	800203B	800203B	800203B
9-H	Sensor Well	007211F	007211F	007211F	007211F
10-H	Well Retaining Clip	300203	300203	300203	300203
J	CONTROL BOX (Atmospheric)				
1-J	Control Box IID/TTD	008042F	008043F	008044F	008045F
	Control Box Lock/TTD	008051F	008052F	008053F	008054F
2-J	Transformer 50VA	006533F	006533F	006533F	006533F
3-J	Ignition Control IID	004817B	004817B	004817B	004817B
	Ignition Control Lock. IID	004818B	004818B	004818B	004818B
4-J	Economaster II Control	004675F	004675F	004675F	004675F
6-J	Toggle Switch	008079F	008079F	008079F	008079F
J	CONTROL BOX (Fan Assisted Low Nox)				
1-J	Control Box IID/TTD	008097F	008098F	008099F	008100F
	Control Box Lock/TTD	008103F	008104F	008105F	008106F
2-J	Transformer 50VA	006533F	006533F	006533F	006533F
3-J	Ignition Control IID	004817B	004817B	004817B	004817B
	Ignition Control Lock. IID	004818B	004818B	004818B	004818B
4-J	Economaster II Control	004675F	004675F	004675F	004675F
5-J	Relay Low Nox Blower	007377F	007377F	007377F	007377F
6-J	Toggle Switch	008079F	008079F	008079F	008079F

*FOR ALTITUDES ABOVE 2,000 FEET LEVEL, CONSULT THE FACTORY

MODELS 181, 264, 331,339 GB

CALL OUT	DESCRIPTION	181	264	331	399
M	MISCELLANEOUS COMPONENTS				
1-M	Switch Plate IID	901401	901401	901401	901401
2-M	PRV 125 PSI	008091F	007224F	007224F	007224F
3-M	Delimiting Kit	052871F	052871F	052871F	052871F
4-M	T & P Gauge (W)	600672	600672	600672	600672
5-M	Pump CIBF	005573	005573	005573	005573
	Pump Brass	005574	005574	005574	005574
6-M	Remote Sensor for Low Water Cut Off	008063F	008063F	008063F	008063F
7-M	Low Water Cut Off PC Board	007157F	007157F	007157F	007157F
8-M	Reset Switch for Low Water Cut Off	005641F	005641F	005641F	005641F
P	PILOT				
1-P	Pilot Nat. IID Atmospheric	002003F	002003F	002003F	002003F
	Pilot Pro. IID Atmospheric	002003F	002003F	002003F	002003F
	Pilot Nat. IID Low Nox	008155F	008155F	008155F	008155F
2-P	Pilot Orifice Nat. IID .020	003903F	003903F	003903F	003903F
	Pilot Orifice Pro. IID .012	004308F	004308F	004308F	004308F
3-P	Ignition Control IID	004817B	004817B	004817B	004817B
	Ignition Control Lock. IID	004818B	004818B	004818B	004818B
4-P	Pilot Mounting Bracket IID Atmospheric	306692	306692	306692	306692
5-P	Pilot Mounting Bracket IID Low Nox	008082F	008082F	008082F	008082F
6-P	Pilot Tube (Specify Length)	400607	400607	400607	400607
7-P	Hi Tension Wire w/Pilot Electrode	007864F	007864F	007864F	007864F
R	REFRACTORY				
1-R	Refractory Common (Left & Right)	005282F	005282F	005282F	005282F
2-R	Refractory Uncommon (Front & Rear)	005283F	005284F	005285F	005286F
3-R	Refractory Retainer Kit	005287F	005288F	005289F	005290F
S	SHEETMETAL				
1-S	Jacket Top (Louvered)	005303F	005304F	005305F	005306F
2-S	Flue Collector	005307F	005308F	005309F	005310F
3-S	Door Assy.	005315F	005316F	005317F	005318F
4-S	Screw & Retainer	006744F	006744F	006744F	006744F
5-S	Control Panel	008064F	008065F	008066F	008067F
6-S	Access Panel	008071F	008071F	008071F	008071F
7-S	Side Panel Right	008068F	008068F	008068F	008068F
8-S	Side Panel Left	008069F	008069F	008069F	008069F
9-S	Side Panel Cap	008070F	008070F	008070F	008070F
10-S	Rear Panel Kit (2 Pcs.)	005278F	005279F	005280F	005281F
11-S	Sub-Base for Combustible Flooring	005182	005183	005184	005185
V	VENTING				
1-V	Draft Hood Kit	008137	008138	008139	008140
2-V	Flue Gas Spillage Sensor	006021F	006021F	N/A	N/A
3-V	"Pagoda" Top	008141	008142	008143	008144

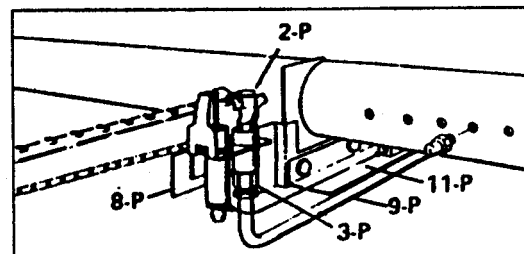
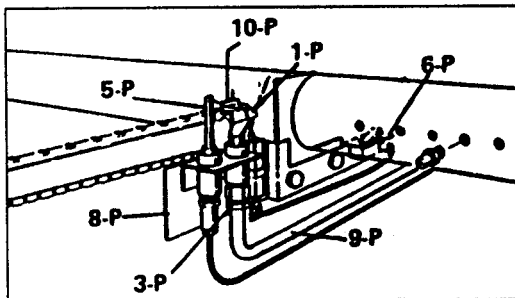
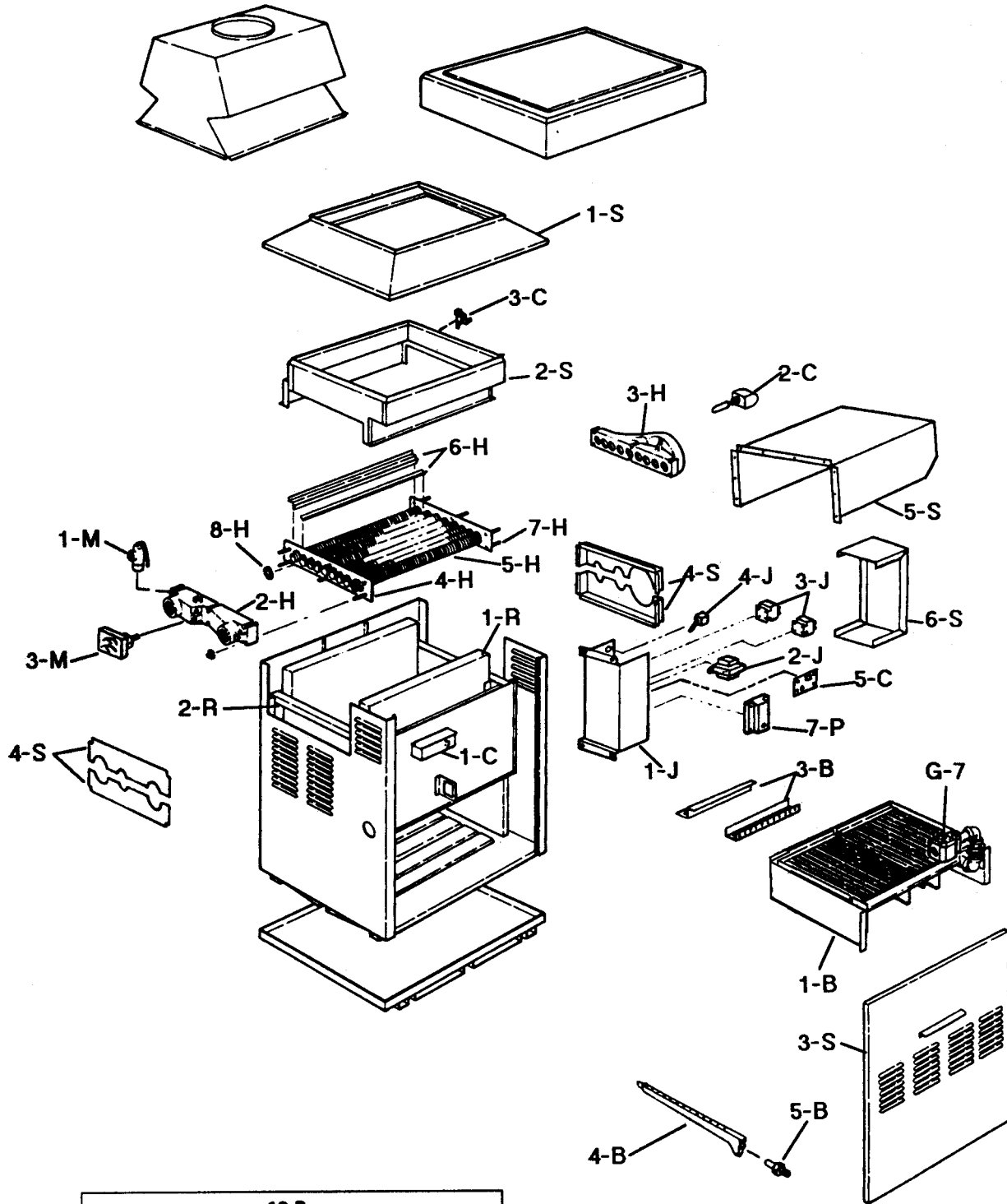

MODELS 512, 627, 726, 825 GB

CALL OUT	DESCRIPTION	512	627	726	825
B BURNER TRAY					
1-B	Burner Tray w/Burner (Sea Level)*	001853F	001855F	001857F	001859F
	Burner Tray w/o Burner (Sea Level)*	001865F	001867F	001869F	001871F
3-B	Burner Spacer/Hold Down Bracket Kit	001877F	001878F	001879F	001880F
4-B	Burner	301210/31	301210/38	301210/44	301210/50
5-B	Burner Orifice Nat. (Sea Level)*	350077F/31	350077F/38	350077F/44	350077F/50
	Burner Orifice Pro. (Sea Level)*	350083F/31	350083F/38	350083F/44	350077F/50
C CONTROLS					
1-C	Manual Hi Limit	008081F	008081F	008081F	008081F
2-C	Flow Switch	007142F	007142F	007142F	007142F
3-C	Thermostat Pump Control	003609F	003609F	003609F	003609F
4-C	Tankstat (Not Shown)	007148F	007148F	007148F	007148F
5-C	Energy Saving Pump Control	004675F	004675F	004675F	004675F
G GAS VALVES					
(SEE GAS VALVE REPLACEMENT CHART) SEE PAGE 52					
H HEAT EXCHANGER					
1-H	Heat Exch.Assy.Cast Iron w/Pump Header	002333F	002334F	002335F	002336F
	Heat Exch. Assy. Brass	002327F	002328F	002329F	002330F
2-H	Inlet/Outlet Header Cast Iron	002219F	002219F	002219F	002219F
	Inlet/Outlet Header Brass	002220F	002220F	002220F	002220F
3-H	Return Pump Header Cast Iron	002223F	002223F	002223F	002223F
	Return Header Brass	002222F	002222F	002222F	002222F
4-H	Tube Bundle	002369F	002370F	001620F	001621F
5-H	Heat Exchange Tube	002381F	002382F	001051F	001051F
6-H	Baffle Kit	001618F	002619F	001527F	001527F
7-H	Stud Bolt Kit	001051F	001051F	001051F	001051F
	Stud Bolt Kit w/Pump Header	001527F	001527F	001527F	001527F
	Stud Bolt Group w/o Header Pump	001051F	001051F	001051F	001051F
8-H	Header Gasket	800001B/9	800001B/9	800001B/9	800001B/9
9-H	Sensor Well	350036	350036	350036	350036
10-H	Well Retaining Clip	300203	300203	300203	300203
J J-BOX/ECONOMASTER					
1-J	J-Box Nat. IID (RI)	002227F	002227F	002227F	002227F
	J-Box Nat. IID/TTD (RC)	004812F	004812F	004812F	004812F
	J-Box Pro. Pro. IID/Lockout (RI)	002230F	002230F	002230F	002230F
	J-Box Pro. IID/TTD Lock (RC)	004814F	004814F	004814F	004814F
2-J	Transformer IID	006533F	006533F	006533F	006533F
3-J	Relay SPST	007377F	007377F	007377F	007377F
4-J	Toggle Switch	008079F	008079F	008079F	008079F
5-J	Relay DPST Pump Control (Not Shown)	008090F	008090F	008090F	008090F
6-J	Relay SPDT Pump Control (Not Shown)	650277F	650277F	650277F	650277F
M MISCELLANEOUS					
1-M	PRV 125 PSI	007224F	007224F	007224F	007224F
2-M	Deliming Kit	052870	052870	052870	052870
3-M	T & P Gauge	007399F	007399F	007399F	007399F
4-M	Integral Pump (Not Shown)	004844F	004844F	004844F	004844F

*For altitudes over 2000 feet above sea level, consult the factory of manufacturer.

MODELS 512, 627, 726, 825 GB

CALL OUT	DESCRIPTION	512	627	726	825
P	PILOT				
2-P	Pilot Nat. IID	002234F	002234F	002234F	002234F
	Pilot Pro. IID	002235F	002235F	002235F	002235F
3-P	Pilot Orifice Nat. IID	600809	600809	600809	600809
	Pilot Orifice Pro. IID	600894	600894	600894	600894
7-P	Ignition Control IID Nat.	004817B	004817B	004817B	004817B
	Ignition Control IID Pro./Lockout	004818B	004818B	004818B	004818B
	Pilot Mounting Bracket IID	304666	304666	304666	304666
9-P	Pilot Tube	400013	400013	400013	400013
11-P	Ignitor Wire IID	650554	650554	650554	650554
12-P	Hi Tension Wire	002663B	002663B	002663B	002663B
R	REFRACTORY				
1-R	Refractory Kit	001314F	001315F	001316F	001317F
2-R	Refractory Retainer Kit	001627F	001627F	001627F	001627F
S	SHEETMETAL				
1-S	Jacket Top	002419F	002420F	002421F	002422F
2-S	Flue Collector	002425F	002426F	002427F	002428F
3-S	Door Assy.	001836F	001837F	001838F	001839F
4-S	Access Panel w/Pump Header	001846F	001846F	001846F	001846F
	Access Panel	001847F	001847F	001847F	001847F
5-S	Pump Cover	002641F	002641F	002641F	002641F
6-S	J-Box Sheetmetal	002668F	002668F	002668F	002668F
V	VENTING				
1-V	Stackless Top Kit (Outdoor)	003586	003587	003588	003589
2-V	Draft Hood (Indoor)	003592	003593	003594	003595

STANDARD PURCHASED REPLACEMENT PARTS			GB			
CALL OUT	DESCRIPTION	PART NO	512	627	726	825
G	GAS VALVES					
1-G	Manual "B" Valve 1/8"	007195F	1	1	1	1
	Manual "A" Valve 1"	007189F	1	1	1	1
2-G	Pressure Regulator Nat. 1/8"	600217	1	1	1	1
	Pressure Regulator Pro. 1/8"	003568F	1	1	1	1
3-G	Pressure Regulator Nat. 1"	007932F	1	1	1	
	Pressure Regulator Pro. 1"	003570F	1	1	1	
	Pressure Regulator Nat. 1-1/4"	600050				1
	Pressure Regulator Pro. 1-1/4"	003571F				1
4-G	Pilot Gas Valve	600562				1
5-G	Auto On/Off Valve 1"	600011				1
	Auto On/Off Valve 3/4"	600007				
	Auto On/Off Valve 1-1/4"	600455				
6-G	Comb. Gas Valve Nat. 3/4"	003900F				
	Comb. Gas Valve Pro. 3/4"	004306F				
	Comb. Gas Valve Nat. 1"	600631				1
	Comb. Gas Valve Pro. 1"	600692				1
	Comb. Step-Opening Valve Nat. 3/4"	003899F				
	Comb. Step-Opening Valve Pro. 3/4"	003569F				
	Comb. Step-Opening Valve Nat. 1"	600870				
	Comb. Step-Opening Valve Pro. 1"	003574F				
	Comb. Gas Valve - IID Nat. 1"	004877F	1	1	1	
	Comb. Gas Valve - IID Pro. 1"	004878F	1	1	1	

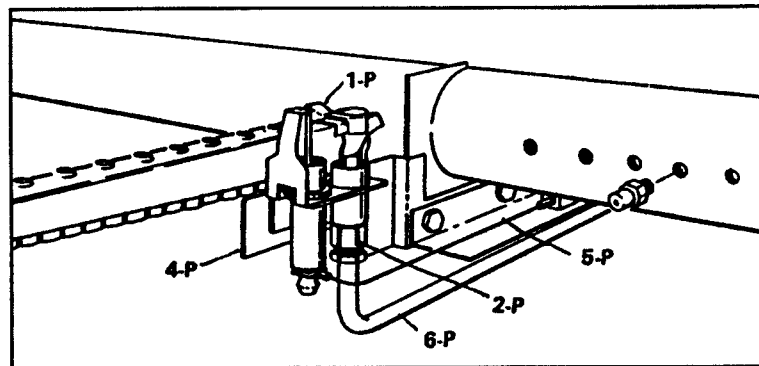
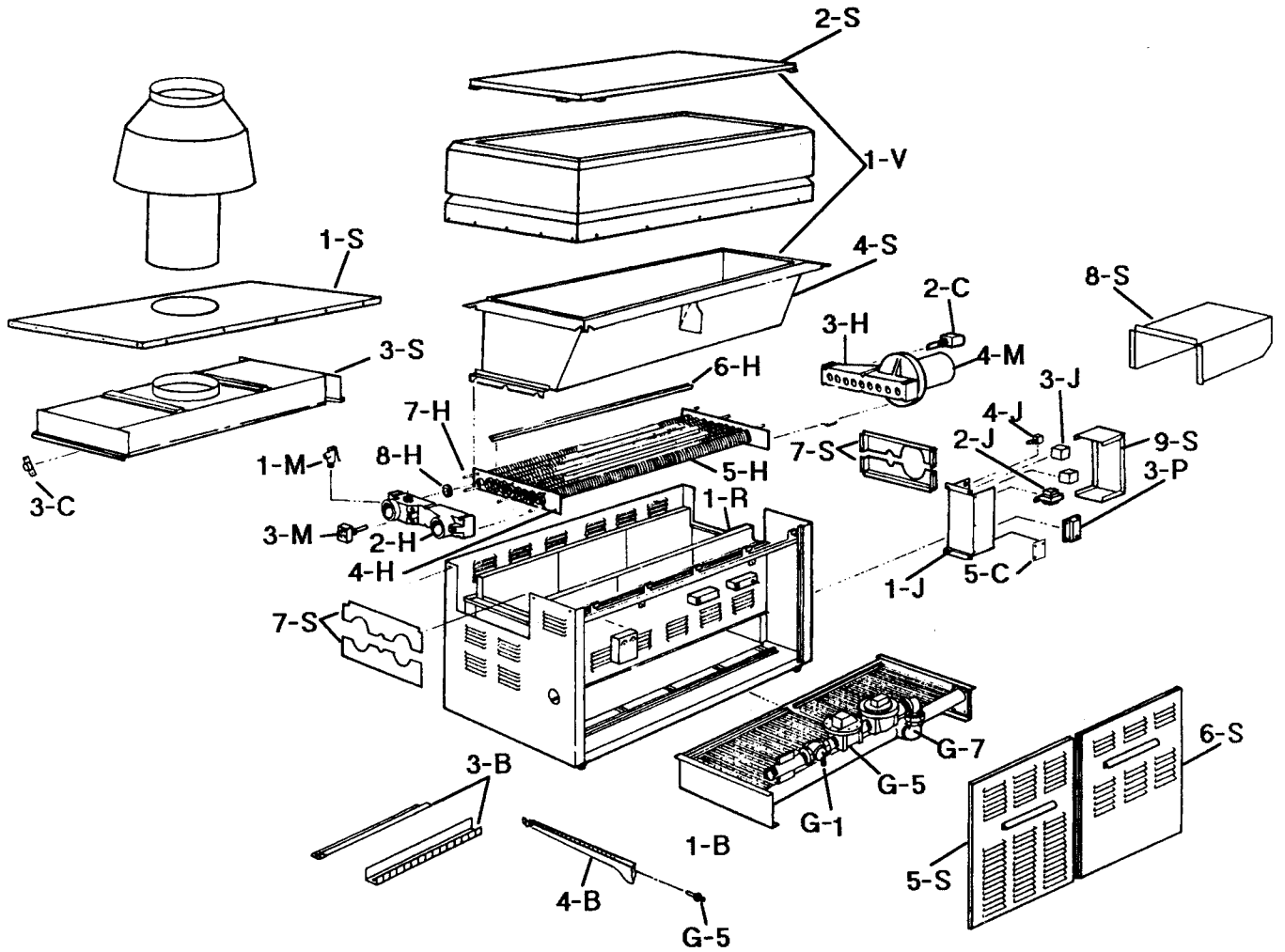

MODELS 926-1826 GB

CALL OUT	DESCRIPTION	962/926	1125/1083	1223/1178	1337/1287	1467/1413	1630/1570	1826/1758
B	BURNER TRAY							
1-B	Burner Tray w/Burners (Sea Level)*	002902F	002093F	002094F	002995F	002096F	002097F	002098F
	Burner Tray w/o Burners (Sea Level)*	002999F	002100F	002101F	002102F	002103F	002104F	002105F
3-B	Burner Spacer/Hold Down	002120F	002121F	002122F	002123F	002124F	002125F	002126F
4-B	Burner	301210/59	301210/69	301210/75	301210/82	301210/90	301210/100	301210/112
5-B	Burner Orifice Nat. (Sea Level)*	350078F/59	350078F/69	350078F/75	350078F/82	350078F/90	350078F/100	350078F/112
	Burner Orifice Pro. (Sea Level)*	350083F/59	350083F/69	350083F/75	350083F/82	350083F/90	350083F/100	350083F/112
C	CONTROLS							
1-C	Manual Hi Limit	008081F	008081F	008081F	008081F	008081F	008081F	008081F
2-C	Flow Switch	007142F	007142F	007142F	007142F	007142F	007142F	007142F
3-C	Thermostat Pump Control	003609F	003609F	003609F	003609F	003609F	003609F	003609F
4-C	Tankstat (Not Shown)	007148F	007148F	007148F	007148F	007148F	007148F	007148F
5-C	Energy Saving Pump Control	004675F	004675F	004675F	004675F	004675F	004675F	004675F
G	GAS VALVES	(SEE GAS VALVE REPLACEMENT CHART) SEE PAGE 55						
H	HEAT EXCHANGER							
1-H	Ht.Ex. Assy. C.I. w/Pump Hdr.	002148F	002149F	002150F	002151F	002152F	002153F	002154F
	Heat Ex. Assy. Brass	002141F	002142F	002143F	002144F	002145F	002146F	002147F
2-H	Inlet/Outlet Hdr. C.I.	002348F	002215F	002215F	002215F	002215F	002215F	002215F
	Inlet/Outlet Header Brass	002216F	002216F	002216F	002216F	002216F	002216F	002216F
3-H	Return Pump Hdr. Cast Iron	002223F	002223F	002223F	002223F	002223F	002223F	002223F
	Return Header Brass	002222F	002222F	002222F	002222F	002222F	002222F	002222F
4-H	Tube Bundle	002187F	002188F	002189F	002190F	002191F	002192F	002193F
5-H	Heat Exchange Tube	002201F	002202F	002203F	002204F	002205F	002206F	002207F
6-H	Baffle Kit	001520F	001521F	001522F	001523F	001524F	001525F	001526F
7-H	Stud Bolt Kit w/Pump Header	001527F	001527F	001527F	001527F	001527F	001527F	001527F
	Stud Bolt Kit w/o Header Pump	001051F	001051F	001051F	001051F	001051F	001051F	001051F
8-H	Header Gasket	800001B	800001B	800001B	800001B	800001B	800001B	800001B
9-H	Sensor Well	007211F	007211F	007211F	007211F	007211F	007211F	007211F
J	J-BOX/ECONOMASTER							
1-J	J-Box Nat. IID	004812F	004812F	004812F	004812F	004812F	004812F	004812F
	J-Box Pro. IID, Lockout	004814F	004814F	004814F	004814F	004814F	004814F	004814F
2-J	Transformer	006533F	006533F	006533F	006533F	006533F	006533F	006533F
3-J	Relay SPST	007377F	007377F	007377F	007377F	007377F	007377F	007377F
4-J	Toggle Switch	008079F	008079F	008079F	008079F	008079F	008079F	008079F
5-J	Relay DPST	650277F	650277F	650277F	650277F	650277F	650277F	650277F
6-J	Relay SPDT	008090F	008090F	008090F	008090F	008090F	008090F	008090F

*For altitudes over 2000 feet above sea level, consult the factory or manufacturer.

MODELS 926-1826 GB

CALL OUT	DESCRIPTION	962/926	1125/1083	1223/1178	1337/1287	1467/1413	1630/1570	1826/1758
M	MISCELLANEOUS							
1-M	PRV 125 PSI	007224F	007224F	007224F	007224F	007224F	007224F	007224F
2-M	Delimiting Kit	052870F	052870F	052870F	052870F	052870F	052870F	052870F
3-M	T & P Gauge	007399F	007399F	007399F	007399F	007399F	007399F	007399F
4-M	Integral Pump	004844F	004844F	004844F	004844F	004844F	004844F	004844F
P	PILOT							
1-P	Pilot Nat. IID	002234F	002234F	002234F	002234F	002234F	002234F	002234F
	Pilot Pro. IID	002235F	002235F	002235F	002235F	002235F	002235F	002235F
2-P	Pilot Orifice Nat. IID	600809	600809	600809	600809	600809	600809	600809
	Pilot Orifice Pro. IID	600894	600894	600894	600894	600894	600894	600894
3-P	Ignition Control Nat. IID	004817B	004817B	004817B	004817B	004817B	004817B	004817B
	Ignition Control Pro. IID/Lockout	004818B	004818B	004818B	004818B	004818B	004818B	004818B
4-P	Pilot Mounting Bracket	304665	304665	304665	304665	304665	304665	304665
5-P	Ignition Wire	650554	650554	650554	650554	650554	650554	650554
6-P	Pilot Tube	400013	400013	400013	400013	400013	400013	400013
7-P	Hi Tension Wire	002663B	002663B	002663B	002663B	002663B	002663B	002663B
R	REFRACTORY							
1-R	Refractory Kit	001002F	001003F	001004F	001005F	001006F	001511F	001512F
2-R	Refractory Retainer Kit	000987F	000988F	000989F	000990F	000991F	001518F	001519F
S	SHEETMETAL							
1-S	Jacket Top (Indoor)	002293F	002294F	002295F	002296F	002297F	002298F	002299F
2-S	Flat Top Assy. (Outdoor)	002312F	002313F	002314F	002315F	002316F	002317F	002318F
3-S	Flue Collector (Indoor)	002248F	002244F	002249F	002250F	002251F	002252F	002253F
4-S	Flue Collector (Outdoor)	002258F	002259F	002260F	002261F	002262F	002263F	002264F
5-S	Door Assy. Left (Indoor)	002265F	002266F	002267F	002268F	002269F	002270F	002271F
	Door Assy. Left (Outdoor)	002279F	002280F	002281F	002282F	002283F	002284F	002285F
6-S	Door Assy. Right (Indoor)	002272F	002273F	002274F	002275F	002276F	002277F	002278F
	Door Assy. Right (Outdoor)	002286F	002287F	002288F	002289F	002290F	002291F	002292F
7-S	Access Panel Group 2-1/2" C.I.	002304F	002304F	002304F	002304F	002304F	002304F	002304F
	Access Panel 2-1/2" Bronze	002303F	002303F	002303F	002303F	002303F	002303F	002303F
8-S	Pump Cover	002671F	002671F	002671F	002671F	002671F	002671F	002671F
9-S	J-Box Sheetmetal	002668F	002668F	002668F	002668F	002668F	002668F	002668F
V	VENTING							
1-V	Stackless Top Kit (Outdoor)	002305F	002306F	002307F	002308F	002309F	002310F	002311F
2-V	Draft Hood (Indoor)	006484	006485	006485	006486	006486	006486	006487

STANDARD PURCHASED REPLACEMENT PARTS			GB						
CALL OUT	DESCRIPTION	PART NO.	962/926	1125/1083	1223/1178	1337/1287	1467/1413	1630/1570	1826/1758
G	GAS VALVES								
1-G	Manual "B" Valve 1/8"	007195F	1	1	1	1	1	1	1
	Manual "A" Valve 1"	007189F	1	1	1				
	Manual "A" Valve 1-1/4"	007190F				1	1	1	
	Manual "A" Valve 1-1/2"	600881							1
2-G	Pressure Regulator Pro. 3/8"	004061F	1	1	1	1	1	1	1
	Pressure Regulator Nat. 3/8"	004062F	1	1	1	1	1	1	1
4-G	Pilot Gas Valve - All Gases	600562	1	1	1	1	1	1	1
5-G	Auto On/Off Valve - All Gases 1"	600011							
	Auto On/Off Valve - All Gases 1-1/4"	600455	1	1	1	1	1	1	1
	Auto On/Off Valve - All Gases 1-1/2"	600498							
7-G	Comb. Gas Valve Nat. 1"	600631	1						
	Comb. Gas Valve Pro. 1"	600692	1	1	1	1	1		
	Comb. Gas Valve Nat. 1-1/4"	600632		1	1	1	1	1	
	Comb. Gas Valve Pro. 1-1/4"	600693			1	1	1	1	1
	Comb. Gas Valve Nat. 1-1/2"	600633							1

NOTE:

To supply the correct part it is important that you state the model number, serial number and type of gas.

Any part returned for replacement under standard company warranties must be properly tagged with the return parts tag, completely filled in with the heater serial number, model number etc., and shipped to the Company freight prepaid.

If determined defective by the Company and within warranty, the part will be returned in kind or equal substitution, freight collect. Credit will not be issued.

Free Manuals Download Website

<http://myh66.com>

<http://usermanuals.us>

<http://www.somanuals.com>

<http://www.4manuals.cc>

<http://www.manual-lib.com>

<http://www.404manual.com>

<http://www.luxmanual.com>

<http://aubethermostatmanual.com>

Golf course search by state

<http://golfingnear.com>

Email search by domain

<http://emailbydomain.com>

Auto manuals search

<http://auto.somanuals.com>

TV manuals search

<http://tv.somanuals.com>