



## COMMERCIAL WATER HEATERS

# ELECTRIC BOOSTER WATER HEATERS 6 KW THRU 18 KW

**RHEEM-RUUD** Electric Booster Water Heaters are specifically designed to fit under counters and deliver 180°F (82°C) sanitizing rinse water for all stationary rack and conveyor type commercial dishwashers. They will raise preheated or cold water to 180°F (82°C) rinse temperature for compliance with Local Health Department Sanitation Codes. In addition, these models can be used as circulating tank commercial electric water heaters for gravity or pump circulation to an auxiliary storage tank.

**SYSTEM SENTINEL** - An exclusive Element Diagnostic Panel. Our new line of electric commercial water heaters now includes a compact instantaneous heater in an expanded range of KW power inputs. The completely redesigned single panel control center with hinged stainless steel door provides ready access to all controls, available for either single or three phase operation, these units provide the most versatile and dependable operation we have ever offered in a compact commercial water heater.

### Engineering Information

Rheemglas® compact commercial electric water heaters are quality engineered models designed to provide the maximum amount of hot water from the energy input of the heating elements. These models include Rheem-Ruud's System Sentinel™, an exclusive Element Diagnostic Panel. A light emitting diode monitors each element's on-off cycle and identifies any nonfunctioning element. The precision thermostat(s) is easily adjustable from 100°F to 180°F (38°C to 82°C), with positive off position at low end temperature range. With the design capability to be connected to 208, 240 and 600 volt, single or three phase power installations, they are ideally suited for a wide variety of water heating systems. Detailed engineering information is available in Tables A & B.

**10 U.S. GALLON  
(37.8 L) CAPACITY**

**208, 240 AND  
600 VOLTAGES**

**COMPACT FOR UNDERCOUNTER  
INSTALLATIONS**



## Construction Features

---

**GLASS LINED STORAGE TANK** - Heavy duty steel tank protects with double coating of exclusive Rheemglas® to resist the corrosive action of hot water. Designed for 150 PSI working pressure. Each tank is supplied with cleanout and two factory installed magnesium anode rods for maximum cathodic protection.

**WATER CONNECTIONS** - Hot outlet and cold inlet are 1-1/4" NPS brass nipples which prevent excessive turbulence of heated water and result in optimum tank draw.

**HEAVY INSULATION** - An effective blanket of insulation completely surrounds tanks to limit heat loss and assure high operating efficiency.

**STAINLESS STEEL DOOR AND CONTROL PANEL** - Ideal for food service applications.

**HEATING ELEMENTS** - Separate elements are of the screw-in type and are made of top quality Nichrome® embedded in magnesium oxide sealed in a tinned copper tube to afford corrosion resistance and long life.

**AUTOMATIC TEMPERATURE CONTROL** - Water temperature is maintained by an external easily adjustable thermostat starting with an OFF position and ranging from 100°F to 180°F (38°C to 82°C) that insure instant power shut off at the selected temperature. Over temperature protection is provided by an immersion high temperature limit control, factory set at 200°F (93°C).

**MAGNETIC CONTRACTORS** - All models equipped with contractors, factory wired for simplicity of installation and economical maintenance throughout life of unit.

**240 VOLT CONTROL CIRCUIT** - all units are furnished with a 240 volt control circuit. All controls (thermostats, high temperature limit, etc.) are operated off of this basic 240 volt control circuit.

**ELECTRICAL CONNECTIONS** - Pre-wired, accessible control box with knock-outs on the side in size selections to match the Canadian Electrical Code. Sizes range from 1/2" to 2". New terminal block will accept both copper and aluminum wire.

**STANDARD EQUIPMENT ASME T&P RELIEF VALVE** - This is a double safety valve that relieves when temperature or pressure becomes excessive.

### STAINLESS STEEL 6" LEGS

**SYSTEM SENTINEL™** - An element diagnostic panel, utilizing light emitting diodes (LED) corresponding to the number and location of each heating element are energized when the electric elements are operating. An unlit LED pinpoints the exact location of a non-functioning element, making element operation diagnosis simple and positive.

### Optional Equipment

---

**ELEMENT FUSING** - In addition to all the above construction features, there is internal fusing available that protects all elements, magnetic contractors, thermostats and internal wiring circuits.

For optional fusing, suffix "F" should be added to the model number. Ex. EG10CF-12KW

**TABLE A – ELECTRICAL CHARACTERISTICS**

INPUT KW	NUMBER OF ELEMENTS	ELEMENT WATTAGE	FULL LOAD CURRENT IN AMPERES					NUMBER OF FUSES 30A CLASS G		NUMBER OF CONTRACTORS	
			208V		240V		600	208/240V	600V	208/240V	600V
			PHASE		PHASE		PHASE				
			1	3	1	3	3				
6	3	2000	29	17	25	14	6	2	2	2	1
9	3	3000	43	25	38	22	9	6	3	2	1
12	3	4000	58	33	50	29	12	6	3	2	1
15	3	5000	72	42	63	36	15	6	3	2	1
18	3	6000	87	50	75	43	18	6	3	2	1

**TABLE B – RECOVERY CAPACITIES**

Recovery in U.S. Gallons/Hr. (GPH) and Liters/Hr. (LPH) at Various Temperature Rises

INPUT KW	EQUIVALENT BTU/HR.	UNITS	40° F	50° F	60° F	70° F	80° F	90° F	100° F	110° F	120° F	130° F	140° F
			(22° C)	(28° C)	(33° C)	(39° C)	(45° C)	(50° C)	(56° C)	(61° C)	(67° C)	(72° C)	(78° C)
6	20,473	GPH	62	50	41	35	31	28	25	23	21	19	18
		LPH	235	188	157	134	117	104	94	85	78	72	67
9	30,710	GPH	93	74	62	53	47	41	37	34	31	29	27
		LPH	352	282	235	201	176	157	141	128	117	108	101
12	40,946	GPH	124	99	83	71	62	55	50	45	41	38	35
		LPH	470	376	313	268	235	209	188	171	157	145	134
15	51,183	GPH	155	124	103	89	78	69	62	56	52	48	44
		LPH	587	470	391	335	294	261	235	213	196	181	168
18	61,420	GPH	186	149	124	106	93	83	74	68	62	57	53
		LPH	705	564	470	403	352	313	282	256	235	217	201

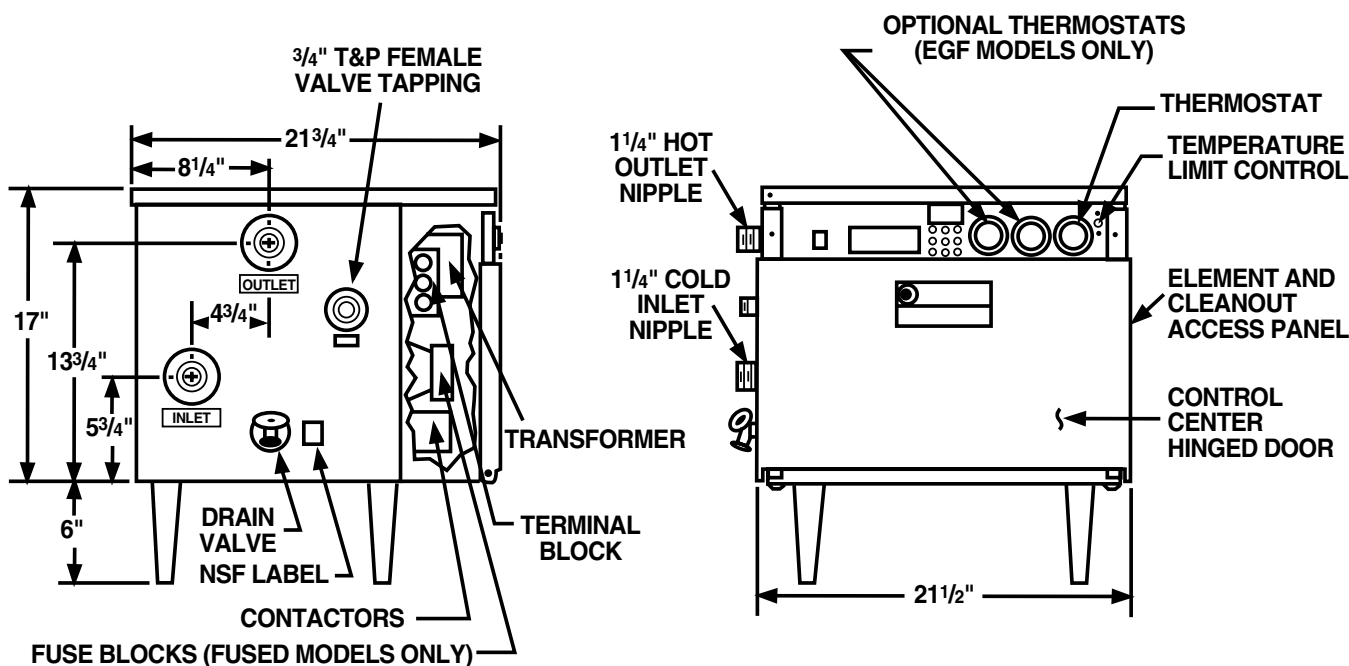

APPROXIMATE WEIGHT 110 LBS.

# RHEEM-RUUD COMMERCIAL ELECTRIC BOOSTER WATER HEATERS

## **SAMPLE SPECIFICATIONS (for trade reference only)**

Water heater shall be Rheemglas Commercial Electric Model \_\_\_\_\_ having an input of \_\_\_\_\_ kW and a recovery rate of \_\_\_\_\_ GPH at a \_\_\_\_\_ ° temperature rise and equipped for \_\_\_\_\_ volt, \_\_\_\_\_ phase operation. Water heater shall be prewired, factory tested and CSA listed. Tank shall be lined with a double coating of exclusive Rheemglas high temperature glass formula and furnished with anode rods rigidly supported. Tank shall be designed for 150 psi working pressure and shall be approve-listed and constructed in accordance with Canadian Electric Code and shall be equipped with cleanout. Tank shall be completely insulated with a heavy blanket of insulation. Water heater tank shall be covered by a limited three year warranty against tank failure.

Water heater shall be equipped with immersion "screw-in" elements, immersion thermostat(s), magnetic contactors, and manual reset high temperature limit control. Large terminal block that accepts either CU or AL filed conect wore, plus grounding screw for attaching equipment grounding connector. Water heater shall include a factory installed System Sentinel™, and Element Diagnostic Panel utilizing light emitting diodes. Each L.E.D. will correspond to the number and location of the heating elements and monitor their on-off function.

## **THREE YEAR LIMITED WARRANTY**

This product features a three year limited warranty against tank leaks. Please refer to Commercial Warranty Information brochure for complete warranty information.



*In keeping with its policy of continuous progress and product improvement, Rheem-Ruud reserves the right to make changes without notice.*

**Rheem Manufacturing Company • Water Heater Division**  
Rheem Canada Ltd./Ltée, 128 Barton Street West, Hamilton, Ontario L8N 3P3  
Customer Service 1-800-268-6966  
Warranty 1-800-263-8342

FORM NO. RR102CE-2CAN Rev.2 03/05 WP



## Free Manuals Download Website

<http://myh66.com>

<http://usermanuals.us>

<http://www.somanuals.com>

<http://www.4manuals.cc>

<http://www.manual-lib.com>

<http://www.404manual.com>

<http://www.luxmanual.com>

<http://aubethermostatmanual.com>

Golf course search by state

<http://golfingnear.com>

Email search by domain

<http://emailbydomain.com>

Auto manuals search

<http://auto.somanuals.com>

TV manuals search

<http://tv.somanuals.com>