

# *Owners Guide and Installation Instructions*

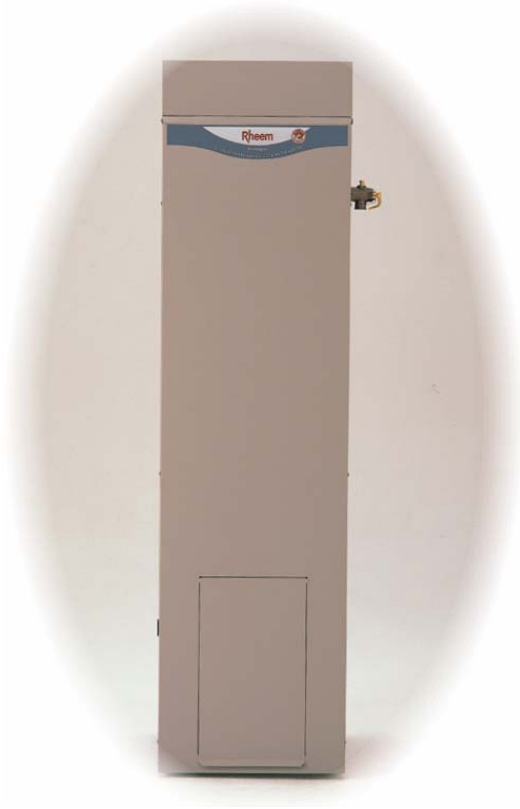

## *Gas Domestic Outdoor Water Heater*



*Install a Rheem*

*This water heater must be installed and serviced by an authorised person.  
Please leave this guide with the householder.*

**Notice to Victorian Customers from the  
Victorian Plumbing Industry Commission.**

**This water heater must be installed by a licensed person as required by  
the Victorian Building Act 1993.**

Only a licensed person will give you a Compliance Certificate, showing that the work complies with all the relevant standards. Only a licensed person will have insurance protecting their workmanship for 6 years. Make sure you use a licensed person to install this water heater and ask for your Compliance Certificate.

**Warning:** Upon completion of the installation and commissioning of the water heater, leave this guide with the householder or responsible officer. **DO NOT** leave this guide inside of the cover of the water heater, as it may interfere with the safe operation of the water heater or ignite when the water heater is turned on.

**PATENTS**

This water heater may be protected by one or more patents or registered designs.

© Registered trademark of Rheem Australia Pty Ltd.

™ Trademark of Rheem Australia Pty Ltd.

Download from [www.Somaterials.com](http://www.Somaterials.com). All Manuals Search And Download.

# CONTENTS

**HOUSEHOLDER – We recommend you read pages 4 to 13.**

The other pages are intended for the installer but may be of interest.

<b>About Your Water Heater .....</b>	<b>4</b>
<b>How Your Water Heater Works.....</b>	<b>8</b>
<b>Regular Care .....</b>	<b>9</b>
<b>Save A Service Call .....</b>	<b>11</b>
<b>Installation.....</b>	<b>14</b>
<b>Connections – Plumbing .....</b>	<b>22</b>
<b>Commissioning.....</b>	<b>25</b>
<b>Lighting The Water Heater .....</b>	<b>26</b>
<b>Draining The Water Heater .....</b>	<b>29</b>
<b>Water Supplies.....</b>	<b>30</b>
<b>Warranty .....</b>	<b>31</b>

# ABOUT YOUR WATER HEATER

## MODEL TYPE

Congratulations for choosing a Rheem® water heater. The model you have chosen is suitable for outdoor installation only. The model is either a 311 series Rheemglas®, 314 series RheemPlus™ or 811 series Optima™ water heater. Optima models have an extended warranty ([refer to the warranty on page 32](#)).

## HOW HOT SHOULD THE WATER BE?

The water heater features a user adjustable thermostat, which allows you to personally choose the most suitable temperature for your hot water needs. Refer to ["Temperature Adjustment"](#) on page 5.

A RheemPlus water heater is temperature limited to deliver water not exceeding 50°C.

To meet the requirements of the National Plumbing Standard the temperature of the stored water must not be below 60°C.

## HOTTER WATER INCREASES THE RISK OF SCALD INJURY

This water heater can deliver water at temperatures which can cause scalding. Check the water temperature before use, such as when entering a shower or filling a bath or basin, to ensure it is suitable for the application and will not cause scald injury.

We recommend and it may also be required by regulations that an approved temperature limiting device be fitted into the hot water pipe work to the bathroom and ensuite when a Rheemglas or Optima water heater is installed. This will keep the water temperature below 50°C at the bathroom and ensuite. The risk of scald injury will be reduced and still allow hotter water to the kitchen and laundry.

A RheemPlus water heater will not deliver temperatures exceeding 50°C, in accordance with AS 3498. There is no statutory requirement to fit a temperature limiting device if this water heater is installed in other than an early childhood centre, school, nursing home or a facility for young, aged, sick or disabled people.

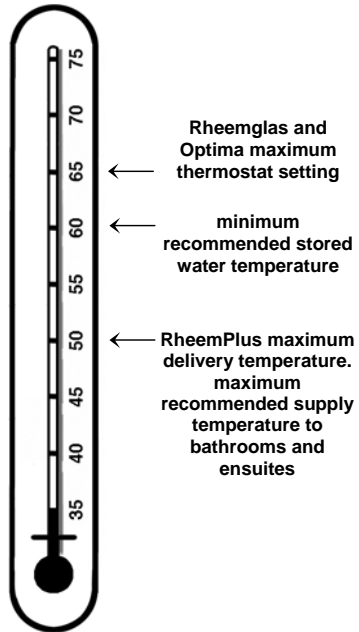

# ABOUT YOUR WATER HEATER

## TEMPERATURE ADJUSTMENT

The temperature adjusting dial is on the gas valve, located behind the access cover on the lower front of the water heater. A setting of '6' will normally maintain the water temperature at about 60°C. Each number represents a temperature difference of approximately 6°C.

To increase the water temperature to 65°C, turn the gas control knob anticlockwise to a setting of '7'. Refer to "[Hotter Water Increases the Risk of Scald Injury](#)" on page 4.

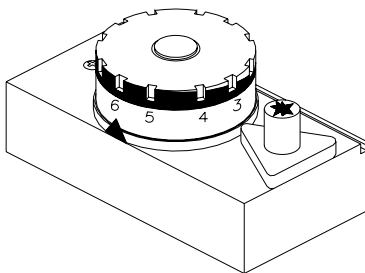

A RheemPlus water heater is temperature limited to 50°C at the hot water outlet. Increasing the thermostat setting will not increase the outlet temperature but will provide more hot water capacity.

## WARNING

This water heater is not intended to be operated, adjusted or tampered with by young children or infirm persons. Young children should be supervised to ensure they do not interfere with the water heater.

## SAFETY

This water heater is supplied with a thermostat, an over-temperature cut-out, and a combination temperature pressure relief valve. In addition, a RheemPlus water heater has a temperature limiting valve. These devices must not be tampered with or removed. The water heater must not be operated unless each of these devices is fitted and is in working order.

**The warranty can become void if relief valves or other safety devices are tampered with or if the installation is not in accordance with these instructions.**

# ABOUT YOUR WATER HEATER

- Do not store **flammable or combustible materials** near the water heater. Flammable liquids (such as petrol), newspapers and similar articles must be kept well away from the water heater and the flue terminal.
- Do not use **aerosols, stain removers and household chemicals** near the water heater whilst it is working. Gases from some aerosol sprays, stain removers and household chemicals become corrosive when drawn into a flame.
- Do not store **swimming pool chemicals, household cleaners**, etc., near the water heater.
- Do not place anything on top of the water heater or in contact with the flue terminal. Ensure the flue terminal is not obstructed in any way at any time.
- Do not use Propane / Butane gas mixtures in a Propane model. A Propane model is designed to operate on Propane only. The use of Propane / Butane mixture, such as automotive LPG fuel, in a Propane model is unsafe and can cause damage to the water heater.



## TO TURN OFF THE WATER HEATER

If it is necessary to turn off the water heater:

- Shut down the gas control (refer to [“Close Down Procedure”](#) on page 29).
- Close the gas isolation valve at the inlet to the gas control.
- Close the cold water isolation valve at the inlet to the water heater.

## TO TURN ON THE WATER HEATER

- Open the cold water isolation valve fully at the inlet to the water heater.
- Open the gas isolation valve fully at the inlet to the gas control.
- Light the water heater (refer to [“Lighting the Water Heater”](#) on page 26).

# ABOUT YOUR WATER HEATER

## HOW DO I KNOW IF THE WATER HEATER IS INSTALLED CORRECTLY?

Installation requirements are [shown on page 20](#). The water heater must be installed by an authorised person and the installation must comply with National Standards AS/NZS 3500.4, AS 5601 and all local codes and regulatory authority requirements. In New Zealand, the installation must conform with the Code of Practice for installation of Gas Appliances NZS 5261 and the New Zealand Building Code.

## DOES THE WATER QUALITY AFFECT THE WATER HEATER?

The water heater is suitable for most public water supplies, however some water qualities may have detrimental effects on the cylinder and fittings. **If you are in a known harsh water area you must read page 30**. If you are not sure, have your water quality checked against the conditions [described on page 30](#).

## HOW LONG WILL THE WATER HEATER LAST?

There are a number of factors that will affect the length of service the water heater will provide. These include the water quality, the water pressure, temperature (inlet and outlet) and the water usage pattern. However, your water heater is supported by a comprehensive warranty ([refer to page 32](#)).

## ANODE PROTECTION

The anode(s) installed in your water heater will slowly dissipate whilst protecting the cylinder. The life of the water heater cylinder may be extended by arranging for an authorised person to inspect the anode(s) and replace if required.

The suggested time after installation when the anode(s) should be inspected is:

Rheemglas	8 years
RheemPlus	8 years
Optima	10 years

For softened water supplies or in areas of poor water quality, it is recommended the anode(s) be inspected 3 years earlier than shown ([refer to "Water Supplies" on page 30](#)).

# HOW YOUR WATER HEATER WORKS

Water is stored in a vitreous enamel lined steel cylinder and heated by a gas burner located under the cylinder. The heat produced by the burner is transferred to the water through the base of the cylinder and through the wall of a flue pipe which passes through the centre of the cylinder. A flue baffle in this flue ensures the efficiency of the water heater is correct. The gas supply to the burner is controlled by the thermostat so the water is heated to a constant temperature. Automatic safety controls are fitted to the water heater to provide safe and efficient operation.

## MAINS PRESSURE

The water heater is designed to operate at mains pressure by connecting directly to the mains water supply. If the mains supply pressure in your area exceeds that [shown on page 15](#), a pressure limiting valve must be fitted. The supply pressure should be greater than 350 kPa for true mains pressure operation to be achieved.

## PIEZO IGNITION

The “Piezo” push button igniter makes lighting the pilot flame of your water heater very easy. Simply follow the instructions on the label attached to the back of the access door. There is no need for matches to light the water heater.

## PILOT IGNITER

A permanent pilot flame burns to ignite the main burner automatically. Heat from the pilot is absorbed by the water.

## GOING ON HOLIDAYS

If you are going on holiday for more than a few days the thermostat can be set to the “★” (pilot) position to conserve energy (refer to point 1 of [“Close Down Procedure”](#) on page 29). If it is necessary to turn off the water heater, refer to [“To Turn Off The Water Heater”](#) on page 6.

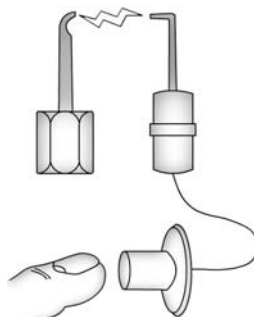



# REGULAR CARE

## TEMPERATURE PRESSURE RELIEF VALVE

This valve is near the top of the water heater and is essential for its safe operation. It is possible for the valve to release a little water through the drain line during each heating period. This occurs as the water is heated and expands by approximately 1/50 of its volume.

Continuous leakage of water from the valve and its drain line may indicate a problem with the water heater (refer to ["Temperature Pressure Relief Valve Running"](#) on page 12).

**WARNING: Never block the outlet of this valve or its drain line for any reason.**

Operate the easing lever on the temperature pressure relief valve once every six months. **It is very important you raise and lower the lever gently.**

**DANGER** – Failure to do this may result in the water heater cylinder failing.

If water does not flow freely from the drain line when the lever is lifted, then the water heater should be checked by the Rheem Service Department or their Accredited Service Agent.

The temperature pressure relief valve should be checked for performance or replaced at intervals not exceeding 5 years, or more frequently in areas where there is a high incidence of water deposits (refer to ["Water Supplies"](#) on page 30).

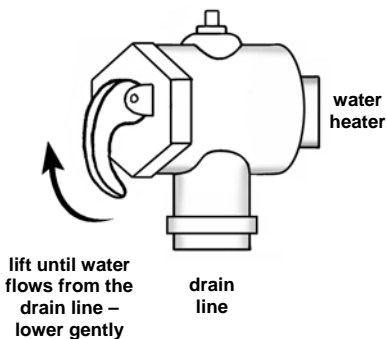
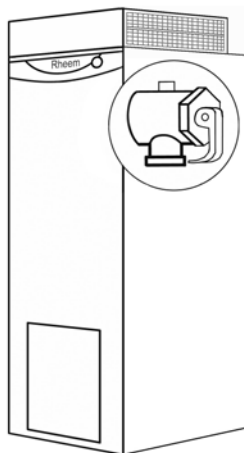

# REGULAR CARE

## TEMPERATURE LIMITING VALVE

A RheemPlus water heater is fitted with a temperature limiting valve at the hot water outlet. The valve is set to deliver water not exceeding 50°C.

The valve should be checked for performance every twelve months. This can be performed by measuring the water temperature from a hot tap with a thermometer. If the water is being delivered at a temperature exceeding 50°C, phone your nearest Rheem Service Department or Accredited Service Agent to arrange for an inspection.

The valve should be replaced at intervals not exceeding 5 years, or more frequently in areas where there is a high incidence of water deposits (refer to “Water Supplies” on page 30). Failure to do this may result in water at a temperature up to 70°C being delivered at the hot tap, increasing the risk of scald injury.

## EXPANSION CONTROL VALVE

In many areas, including South Australia, Western Australia and scaling water areas, an expansion control valve is fitted to the cold water line to the water heater. Water will flow from its drain line during the heating period.

Operate the easing lever on the expansion control valve once every six months. **It is very important you raise and lower the lever gently.** The expansion control valve should be checked for performance or replaced at intervals not exceeding 5 years, or more frequently in areas where there is a high incidence of water deposits.

## SERVICING

For safe and efficient operation, the water heater should be serviced annually by your nearest Rheem Service Department or their Accredited Service Agent. Only genuine replacement parts should be used on this water heater.

**Warning:** Servicing of a gas water heater should only be carried out by authorised personnel.

## SAVE A SERVICE CALL

Check the items below before making a service call. You will be charged for attending to any condition or fault that is not related to manufacture or failure of a part.

### NOT ENOUGH HOT WATER (OR NO HOT WATER)

- **Are you using more hot water than you think?**

Is one outlet (especially the shower) using more hot water than you think? Very often it is not realised the amount of hot water used, particularly when showering. Carefully review the family's hot water usage. Have your plumber fit a flow control valve to each shower outlet to reduce water usage.



- **Pilot flame alight?**

Check the pilot flame is burning by removing the access cover. Relight the pilot flame according to the lighting instructions (refer to "[Lighting the Water Heater](#)" on page 26).

- **Temperature pressure relief valve running**

Is the relief valve discharging too much water? (Refer to "[Temperature Pressure Relief Valve Running](#)" on page 12).

- **Thermostat setting**

Ensure the thermostat setting is appropriate. You may choose to adjust the thermostat upwards to gain additional hot water capacity.

**Note:** Hotter water increases the risk of scald injury.

A RheemPlus water heater is temperature limited to 50°C at the hot water outlet. Increasing the thermostat setting will not increase the outlet temperature but will provide more hot water capacity.

- **Water heater size**

Do you have the correct size water heater for your requirements? The sizing guide in the Rheem sales literature and on the Rheem website ([www.rheem.com.au](http://www.rheem.com.au)) suggests average sizes that may be needed.

# SAVE A SERVICE CALL

## WATER NOT HOT ENOUGH

You may find that due to heavy hot water usage the water temperature may be lower than normally expected.

## WATER TEMPERATURE TOO HIGH

A RheemPlus water heater is fitted with a temperature limiting valve set to deliver water not exceeding 50°C. If the water is being delivered at a temperature exceeding 50°C, phone your nearest Rheem Service Department or Accredited service Agent to arrange for an inspection. Care must be taken by all householders when using hot water until the valve is serviced or replaced.

## TEMPERATURE PRESSURE RELIEF VALVE RUNNING

### • Normal Operation

It is normal and desirable this valve allows a small quantity of water to escape during the heating cycle. However, if it discharges more than a bucket full of water in 24 hours, there may be another problem.

### • Continuous dribble

Try gently raising the easing lever on the relief valve for a few seconds (refer to [“Temperature Pressure Relief Valve”](#) on page 9). This may dislodge a small particle of foreign matter and clear the fault. Release the lever gently.

### • Steady flows for long period (often at night)

This may indicate the mains water pressure sometimes rises above the designed pressure of the water heater. Ask your installing plumber to fit a pressure limiting valve.

**NEVER** replace the relief valve with one of a higher pressure rating.

### • Heavy flows of hot water until the water heater is cold - then stops until water reheats

The gas control **must** be turned off using the knob on top of the gas control thermostat (refer to [“Close Down Procedure”](#) on page 29). Phone your nearest Rheem Service Department or Accredited Service Agent to arrange for inspection.

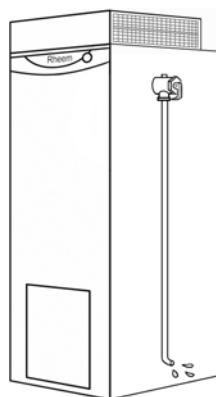

# SAVE A SERVICE CALL

## EXPANSION CONTROL VALVE RUNNING

If an expansion control valve is fitted in the cold water line to the water heater (refer to page 22) it may discharge a small quantity of water instead of the temperature pressure relief valve on the water heater. The benefit is that energy is conserved as the discharged water is cooler.

## CAN'T LIGHT THE PILOT FLAME

- **Is there gas to the water heater?**  
Check the gas isolation valve on the gas supply line is open.
- **Is there a normal gas supply to the rest of the premises?**  
Try lighting another gas appliance to check. If there is no gas, call the gas supplier.

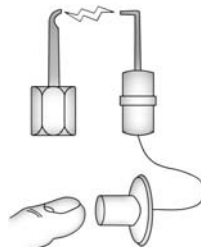

## WATER HEATER APPEARS TO BE LEAKING

When the water heater is first lit, or after a large usage of hot water, condensation may form on the burner of the water heater. This is quite normal, especially in winter months and will dry off as the water is heated.

## HIGH GAS BILLS

Should you at any time, feel your gas account is too high, we suggest you check the following points:

- Is the relief valve running excessively? (Refer to “Temperature Pressure Relief Valve Running” on page 12).
- Is one outlet (especially the shower) using more hot water than you think? (Refer to “Not Enough Hot Water” on page 11).
- Is there a leaking hot water pipe, dripping hot water tap, etc? Even a small leak will waste a surprising quantity of hot water and gas. Replace faulty tap washers, and have your plumber rectify any leaking pipe work.
- Consider recent changes to your hot water usage pattern and check if there has been any increase in tariffs since your previous account.



**IF YOU HAVE CHECKED ALL THE FOREGOING AND STILL BELIEVE YOU NEED ASSISTANCE, CALL YOUR NEAREST RHEEM SERVICE DEPARTMENT OR ACCREDITED SERVICE AGENT.**

# INSTALLATION

**THIS WATER HEATER IS FOR OUTDOOR INSTALLATION ONLY.  
THIS WATER HEATER IS NOT SUITABLE FOR POOL HEATING.  
Check the water heater is suitable for the gas type available  
(refer to the rating label on the water heater).**

## **WATER HEATER LOCATION**

The water heater should be installed close to the most frequently used outlet and its position chosen with safety and service in mind. Make sure people (particularly children) will not touch the flue outlet. The flue terminal must be clear of obstructions and shrubbery.

Clearance must be allowed for servicing of the water heater. The water heater must be accessible without the use of a ladder or scaffold. Make sure the temperature pressure relief valve lever is accessible and the front cover and burner can be removed for service.

If possible leave headroom of one water heater length so the anode can be inspected or replaced. Remember you may have to remove the entire water heater later for servicing.

The installation must comply with the requirements of AS/NZS 3500.4, AS 5601 and all local codes and regulatory authority requirements. In New Zealand, the installation must conform with NZS 5261 Code of Practice for Installation of Gas Burning Appliances and the New Zealand Building Code.



The water heater must not be installed in an area with a corrosive atmosphere where chemicals are stored or where aerosol propellants are released. Remember the air may be safe to breathe, but when it goes through a flame, chemical changes take place which may attack the water heater.

# INSTALLATION

The water heater is to be installed at ground level on a concrete or brick plinth (fire proof base) and must stand vertically upright with the back of the water heater **against an external wall** or alternatively against a fireproof screen extending at least 500 mm above, below and either side the flue terminal. Failure to observe this precaution can cause problems in high wind areas. The water heater must be secured to the wall or screen using the brackets provided. A secondary flue is not required.

Kits are available to enable the water heater to be installed partially recessed into an external wall.

As a guide the following requirements extracted from the Australian Gas Installations Standard AS 5601, must be observed:

- At least 300 mm between the top of the water heater and the eaves.
- At least 500 mm between the water heater and the edge of any opening into the building, measured horizontally and vertically.
- At least 500 mm between the water heater and a return wall or external corner, measured horizontally along the wall.
- At least 500 mm below any openable window.
- At least 500 mm clear of any combustibles.

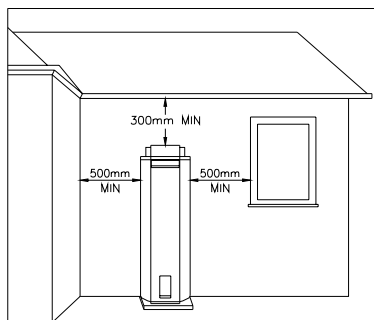

## MAINS WATER SUPPLY

Where the mains water supply pressure exceeds that shown in the table below, an approved pressure limiting valve is required and should be fitted as shown in the installation diagram (refer to diagram on page 22).

Model	090 – 170
Relief valve setting	1400 kPa
Expansion control valve setting *	1200 kPa
<b>Max. mains supply pressure</b>	
With expansion control valve	960 kPa
Without expansion control valve	1120 kPa

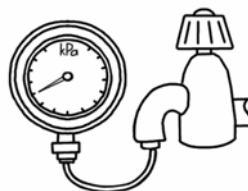

\* Expansion control valve not supplied with the water heater.

# INSTALLATION

## TANK WATER SUPPLY

If the water heater is supplied with water from a tank supply, then the bottom of the supply tank must be at least 1 m above the highest hot water outlet. Take care to avoid air locks. The cold water line to the water heater should be adequately sized and fitted with a full flow gate valve or ball valve.

## HOT WATER DELIVERY

This water heater can deliver water at temperatures which can cause scalding.

It is necessary and we recommend that a temperature limiting device be fitted between a Rheemglas or Optima water heater and hot water outlets in any ablution and public areas such as a bathroom, ensuite or public amenities, to reduce the risk of scalding. The installing plumber may have a legal obligation to ensure the installation of this water heater meets the delivery water temperature requirements of AS/NZS 3500.4 so that scalding water temperatures are not delivered to a bathroom, ensuite or other ablution or public area.

Where a temperature limiting device is installed adjacent to the water heater, the cold water line to the temperature limiting device can be branched off the cold water line either before or after the isolation valve, pressure limiting valve and non return valve to the water heater. If an expansion control valve is required, it must always be installed after the non return valve and be the last valve prior to the water heater.

If a pressure limiting valve is installed on the cold water line to the water heater and the cold water line to a temperature limiting device branches off before this valve or from another cold water line in the premises, then a pressure limiting valve may be required prior to the temperature limiting device.

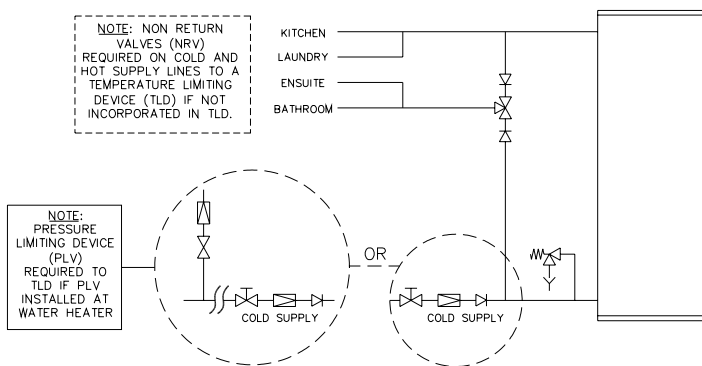

**Two Temperature Zones Using a Temperature Limiting Device**



# INSTALLATION

A RheemPlus water heater will not deliver temperatures exceeding 50°C, in accordance with AS 3498. There is no statutory requirement to fit a temperature limiting device if this water heater is installed in other than an early childhood centre, school, nursing home or a facility for young, aged, sick or disabled people.

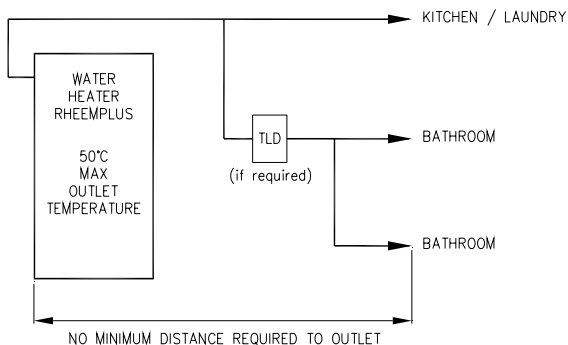

## CIRCULATED HOT WATER FLOW AND RETURN SYSTEM

A RheemPlus water heater cannot be installed as part of a circulated hot water flow and return system in a building.

If a Rheem water heater is to be installed as part of a circulated hot water flow and return system, a storage water heater able to provide a hot water outlet temperature of at least 60°C must be used. **Note:** The thermostat must always be set to at least 60°C. Refer to the [diagram on page 18](#).

## Temperature Limiting Device

A temperature limiting device cannot be installed in circulated hot water flow and return pipe work. The tempered water from a temperature limiting device cannot be circulated. Where a circulated hot water flow and return system is required in a building, a temperature limiting device can only be installed on a dead leg, branching off the circulated hot water flow and return pipe.

If circulated tempered water were to be returned back to the water heater, depending on the location of the return line connection on the water supply line to the water heater, then either:

- water will be supplied to the cold water inlet of the temperature limiting device at a temperature exceeding the maximum recommended water supply temperature, or
- when the hot taps are closed no water will be supplied to the cold water inlet of the temperature limiting device whilst hot water will continue to be supplied to the hot water inlet of the temperature limiting device.

# INSTALLATION

These conditions may result in either water at a temperature exceeding the requirements of AS/NZS 3500.4 being delivered to the hot water outlets in the ablution areas, or the device closing completely and not delivering water at all, or the device failing. Under either condition, the operation and performance of the device cannot be guaranteed.

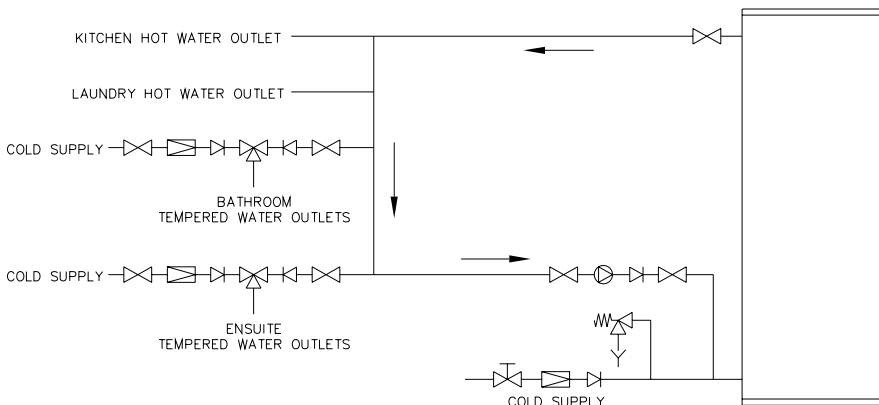

**Circulated Hot Water Flow and Return System – Gas Water Heater**

## REDUCING HEAT LOSSES

The cold water line to and the hot water line from the water heater must be insulated in accordance with the requirements of AS/NZS 3500.4. The insulation must be weatherproof and UV resistant if exposed.

## ANODE TYPES

The correct anode type for the water supply being used must be fitted in the water heater (refer to [“Water Supplies”](#) on page 30). The black anode is fitted as standard.

Total Dissolved Solids in water supply to the water heater	Anode colour code
0 – 40 mg/L	Green
40 – 600 mg/L	Black
600 – 2500 mg/L	Blue

# INSTALLATION

## **SADDLING - PIPE WORK**

To prevent damage to the cylinder when attaching pipe clips or saddles to the water heater jacket, we recommend the use of self-drilling screws with a maximum length of 12 mm. Should pre drilling be required, extreme caution must be observed when penetrating the jacket of the water heater.

**Note: Damage to the cylinder as a result of saddling to the jacket will void the warranty.**

# INSTALLATION

## TYPICAL INSTALLATION – OUTDOOR LOCATION

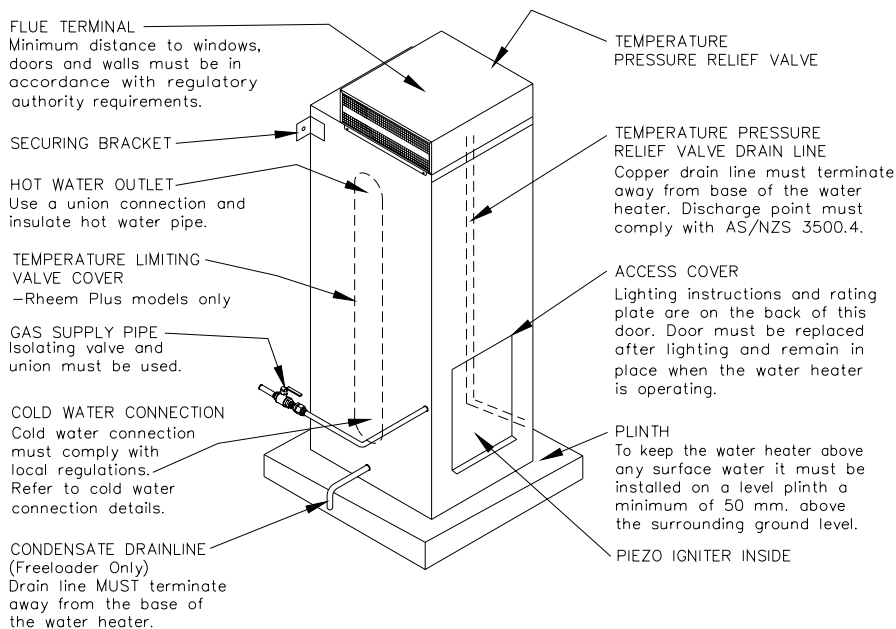

Gas Details	Hourly Gas Consumption (MJ)			Min. Gas Pressure (kPa)	Test Point Gas Pressure (kPa)			Max. Gas Pressure (kPa)
	090	135	170	090 to 170	090	135	170	090 to 170
Natural	30	35	40	1.13	1.00	1.00	1.00	3.50
Propane	30	35	40	2.75	2.70	2.70	2.70	3.50
Butane	30	30	30	2.75	2.70	2.70	2.70	3.50
Town / TLP	27/25	32/30	38/35	0.75	0.45	0.40	0.35	3.50

Model numbers: N = Natural, P = Propane, B = Butane, T = Town / TLP. Letter N, P, B or T is included in the model number, eg 311135NO, to denote gas type.

Specifications are subject to change with ongoing product improvements.

# INSTALLATION

## DIMENSIONS AND TECHNICAL DATA

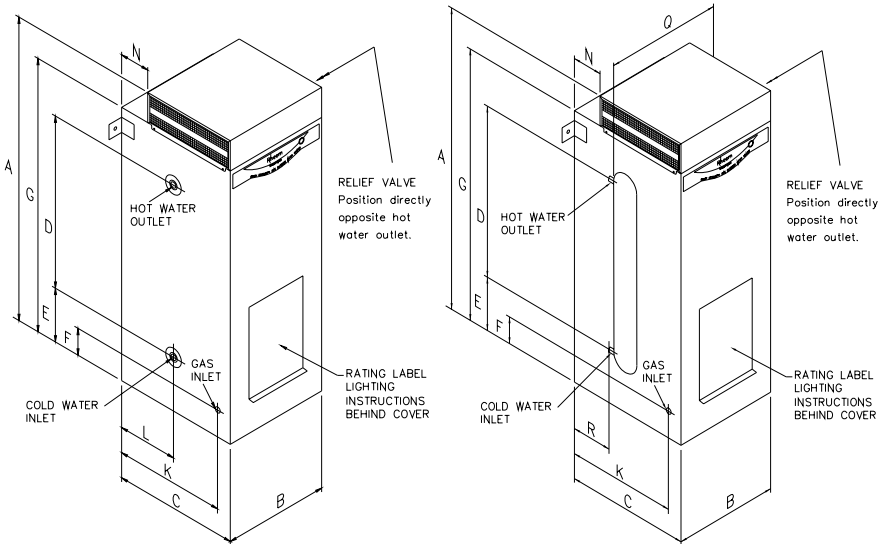

**Rheemglas and Optima**

**RheemPlus**

Rheemglas			311 090	311 135	311 170
Optima			--	811 135	811 170
RheemPlus			--	314 135	314 170
Storage capacity		litres	85	130	160
Dimensions	A	mm	1198	1598	1898
	B	mm	422	422	422
	C	mm	502	502	502
	D	mm	588	988	1213
	E	mm	328	328	403
	F	mm	298	298	298
	G	mm	1078	1478	1778
	K	mm	473	473	473
	L	mm	208	208	208
	N	mm	135	135	135
	Q	mm	-	480	480
	R	mm	-	170	170
Weight	empty	kg	52	68	79
	full	kg	137	198	239

# CONNECTIONS – PLUMBING

## CONNECTION SIZES

	Rheemglas, Optima	RheemPlus
• Hot water connection:	RP ¾/20	G ¾ B
• Cold water connection:	RP ¾/20	G ¾ B
• Relief valve connection:	RP ½/15	RP ½/15
• Gas inlet:	RP ½/15	RP ½/15

All plumbing work must be carried out by a qualified person and in accordance with the National Plumbing Standard AS/NZS 3500.4 and local authority requirements.

All gas work must be carried out by a qualified person and in accordance with the Australian Gas Installations Standard AS 5601 and local authority requirements.

## WATER INLET AND OUTLET

All pipe work must be cleared of foreign matter before connection and purged before attempting to operate the water heater. All olive compression fittings must use brass or copper olives. Use thread sealing tape or approved thread sealant on all fittings.

An isolation valve and non return valve must be installed on the cold water line to the water heater. Use the arrangement shown in the diagram. Refer also to “Hot Water Delivery” on page 16.

A disconnection union must always be provided at the cold water inlet and hot water outlet on the water heater to allow for disconnection of the water heater.

All water heaters have a plastic dip tube or fitting liner in the inlet and outlet fittings (see diagram). These must be in place for the water heater to function properly. Do not remove or damage them by using heat nearby. They will be pushed into the correct position as the fitting is screwed in.

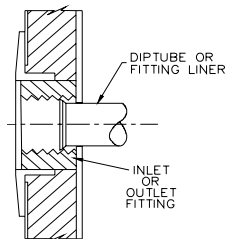
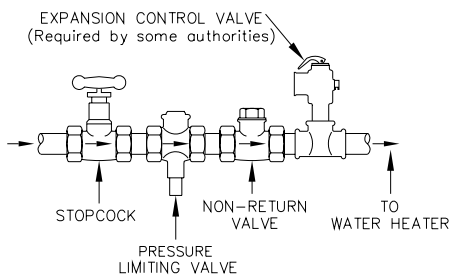

# CONNECTIONS – PLUMBING

## **GAS INLET**

The gas connection is made through the grommet in the left hand side panel to the gas control. The pipe work must be cleared of foreign matter before connection and purged before attempting to light the water heater. An isolation valve and disconnection union must be installed to allow servicing and removal of the water heater. Refer to the Gas Installations Standard AS 5601 for the correct pipe sizing.

**Warning:** Always isolate the water heater before pressure testing the gas supply system. Disconnect the water heater after the isolating cock to prevent the risk of serious damage to the gas control. Warranty does not cover damage of any nature resulting from failure to observe this precaution. Refer to rating label for gas types and pressures.

**Caution:** Care is necessary when tightening fittings into the gas valve. The gas valve casting may crack if the fittings are over tightened. Cracked valve castings are not covered under warranty. Damaged valves must be replaced.

## **PIPE SIZES**

To achieve true mains pressure operation, the cold water line to the water heater should be the same size or bigger than the hot water line from the water heater.

The pipe sizing for hot water supply systems should be carried out by persons competent to do so, choosing the most suitable pipe size for each individual application. Reference to the technical specifications of the water heater and local regulatory authority requirements must be made.

## **RELIEF VALVE**

The temperature pressure relief valve is shipped behind the front cover. This valve must be fitted before the water heater is operated. Before fitting the relief valve, make sure the probe has not been bent. Seal the thread with Teflon tape - never hemp. Make sure the tape does not hang over the end of the thread.

Screw the valve into the correct opening ([refer to the installation diagram on page 20](#)) leaving the valve outlet pointing downwards. Do not use a wrench on the valve body - use the spanner flats provided.

# CONNECTIONS – PLUMBING

## RELIEF VALVE DRAIN

A copper drain line must be fitted to the relief valve to carry the discharge clear of the water heater. Connect the drain line to the relief valve using a disconnection union. The pipe work from the relief valve to the drain should be as short as possible and fall all the way from the water heater with no restrictions. It should have no more than three right angle bends in it. Use DN15 pipe.

The outlet of the drain line must be in such a position that flow out of the pipe can be easily seen (refer to AS/NZS 3500.4) - but arranged so hot water discharge will not cause injury, damage or nuisance. The drain line must discharge at an outlet or air break not more than 9 metres from the relief valve.

In locations where water pipes are prone to freezing, the drain line must be insulated and not exceed 300 mm in length. In this instance, the drain line is to discharge into a tundish through an air gap of between 75 mm and 150 mm.

**Warning:** As the function of the temperature pressure relief valve on this water heater is to discharge high temperature water under certain conditions, it is strongly recommended the pipe work downstream of the relief valve be capable of carrying water exceeding 93°C. Failure to observe this precaution may result in damage to pipe work and property.

## EXPANSION CONTROL VALVE

Local regulations may make it mandatory to install an expansion control valve (ECV) in the cold water line to the water heater. In other areas, an ECV is not required unless the saturation index is greater than +0.4 (refer to “[Water Supplies](#)” on page 30). However, an ECV may be needed in a corrosive water area where there are sufficient quantities of silica dissolved in the water.

The expansion control valve must always be installed after the non return valve and be the last valve installed prior to the water heater (refer to [diagram on page 22](#)). A copper drain line must be run separately from the drain of the relief valve.



# COMMISSIONING

## TO FILL AND TURN ON THE WATER HEATER

The gas pilot or burner must not be lit until the water heater is filled with water.

- Open all of the hot water taps in the house (don't forget the shower).
- Open the cold water isolation valve fully to the water heater.  
Air will be forced out of the taps.
- Close each tap as water flows freely from it.
- Check the pipe work for leaks.
- Open the gas isolation valve fully.
- Check the gas pipe work for leaks.
- Light the water heater (refer to "[Lighting the Water Heater](#)" on page 26).

**Warning:** Upon completion of the installation and commissioning of the water heater, leave this guide with the householder or responsible officer. **DO NOT** leave this guide inside of the cover of the water heater, as it may interfere with the safe operation of the water heater or ignite when the water heater is turned on.

## GAS INLET PRESSURE

**IMPORTANT – CHECK** the gas supply pressure at the inlet to the water heater with the water heater and all other gas burning appliances in the premises operating (burners alight). The minimum gas supply pressure is:

Natural Gas	1.13 kPa	Propane	2.75 kPa
Town / TLP	0.75 kPa	Butane	2.75 kPa

If this minimum cannot be achieved, it may indicate the meter or the gas line to the water heater is undersized. It is important to ensure that an adequate gas supply pressure is available to the water heater when other gas burning appliances, on the same gas supply, are operating.

## TO TURN OFF THE WATER HEATER

If it is necessary to turn off the water heater on completion of the installation, such as on a building site or where the premises is vacant, then:

- Shut down the gas control (refer to "[Close Down Procedure](#)" on page 29).
- Close the gas isolation valve at the inlet to the gas control.
- Close the cold water isolation valve at the inlet to the water heater.

# LIGHTING THE WATER HEATER

## FOR YOUR SAFETY READ BEFORE LIGHTING

**Warning:** This gas water heater is designed to operate reliably and safely as long as the operating instructions are followed **exactly**. You must comply with these lighting instructions at every stage.

**Make sure the water heater is filled with water and the water supply is on, otherwise serious damage to the vitreous enamel cylinder lining and plastic components may occur.**

The installer must check all gas connections for leaks, gas supply pressure and test point pressure (refer rating label). Remove the access cover at the front of the water heater to access the gas thermostat.

## SAFETY INFORMATION

- A. This water heater is equipped with an igniter button which lights the pilot. When lighting the pilot follow these instructions exactly.
- B. **Before lighting** ensure there is no smell of gas around or in the vicinity of the water heater and the burner opening. Be sure to smell next to ground level as some gases can settle there.
- C. What to do if you smell gas.

Do not try to light the water heater.

If the gas smell is throughout the area, turn the gas control knob clockwise to the “●” (off) position and then turn off the isolation valve on the gas line to the water heater. Leave the area and call Rheem Service or a qualified service technician.

- D. Use only your hand to turn the gas control knob, never use tools. If the control knob will not turn by hand, don't try to repair it, call a qualified service technician. Force or attempted repair may cause a fire or explosion.
- E. Do not attempt to operate this water heater if it has been damaged. Call a qualified service technician.

# LIGHTING THE WATER HEATER

## LIGHTING INSTRUCTIONS

Using the gas control light the water heater as follows:

1. **Stop**, read the [safety information](#) on page 26.
2. Turn the gas control knob fully clockwise to the “●” (off) position.
3. Wait five (5) minutes so any build up of unburnt gas can escape. If you then smell gas, stop and follow “C” in the safety information. If you do not smell gas, proceed to step 4.
4. Turn the knob to the “★” (pilot) position.
5. Depress the knob fully (until star disappears below housing) and after 30 seconds, whilst keeping the knob depressed, repeatedly press the igniter button (for up to 40 seconds) until the pilot flame ignites.

**Warning:** Keep your face clear of the combustion chamber opening while pressing the igniter.

**Note:** It is not possible to depress the knob fully if the gas control has activated its safety shut-off feature. In this case, wait 60 seconds for the gas control to reset.

6. Keep the knob depressed for 20 seconds after the pilot flame lights. The pilot can be checked by looking through the large opening below the gas control.
7. Release the knob and check the pilot is still alight.
8. If the pilot has failed to light or has not remained alight, turn the gas control knob to the “●” (off) position. Wait five (5) minutes for any unburnt gas to escape and then begin again at step 3.

**Note: Failure to wait five (5) minutes may result in a fire or explosion.**

9. When the pilot flame remains alight with the gas control knob released, turn the knob anticlockwise to the setting of ‘6’. This will give a water temperature of about 60°C.
10. Refer to [“Temperature Adjustment”](#) on page 5, if further temperature adjustment is required.
11. Replace the access cover.

The main burner will now automatically ignite when heating is required and extinguish when the water has been heated to the set temperature. If the main burner does not light at the selected setting, the water may already be at the selected temperature.

**Note:** Never press the igniter button while the top knob is in a numbered position.

# LIGHTING THE WATER HEATER

## TEST THE WATER HEATER AFTER INSTALLATION

- The operation of the water heater must be thoroughly checked by the installer.
- The burner flame must light smoothly and quickly from the pilot flame, and must go out quietly and completely.
- The main burner flame must be stable, although slight lifting at the front edge of the burner is acceptable when the burner is cold.
- The main burner flame should be blue, with a clearly defined inner cone - luminous yellow or "floating" flames are not acceptable, and must be corrected by opening the air shutter (refer to "Air Shutter" on page 28).
- Check the test point pressure and compare with the rating label. The pressure regulator is not adjustable and if the test point pressure is not within 5% of the specified value, refer to Rheem or their Accredited Service Agent.
- If unable to get the water heater working properly, contact the nearest Rheem Service Department or their Accredited Service Agent.
- When satisfied everything is working properly instruct the user in the correct method of operation.

## AIR SHUTTER

The air shutter is a hinged flap in the burner aeration tube. It may require adjustment on installation.

- For a Propane and Butane model, the air shutter should be fully open.
- For a Town and TLP model, the air shutter should be within 10 mm of the top of the burner aeration tube.
- The shutter is held in place by a screw on the side of the burner aeration tube.

**Note:** A Natural gas model does not have an air shutter.

# LIGHTING THE WATER HEATER

## CLOSE DOWN PROCEDURE

1. Turn the gas control knob to the "★" position (pilot). This setting will leave the pilot flame alight however the main burner will not be able to light.
2. Turn the gas control knob to the "●" (off) position. This setting shuts the gas control down completely.

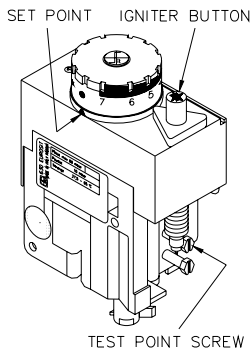

# DRAINING THE WATER HEATER

To drain the water heater:

- Turn off the water heater (refer to ["To Turn Off The Water Heater"](#) on page 25).
- Close all hot water taps.
- Operate the relief valve release lever - do not let the lever snap back or you will damage the valve seat.

Operating the lever will release the pressure in the water heater.

- Undo the union at the cold water inlet to the water heater and attach a hose to the water heater side of the union.

Let the other end of the hose go to a drain.

- Operate the relief valve again.

This will let air into the water heater and allow the water to drain through the hose.

# WATER SUPPLIES

Your water heater is manufactured to suit the water conditions of most Australian metropolitan supplies. However, there are some known water supplies which can have detrimental effects on the water heater and its operation and/or life expectancy. If you are unsure of your water quality, you can obtain information from your local water supply authority.

## ANODE

In areas where the total dissolved solids (TDS) exceeds 600 mg/L it is possible the black anode, which is the standard anode fitted to the water heater, may be excessively active. To alleviate this, the black anode should be replaced with one colour coded blue. Where the TDS of the water is less than 40 mg/L, such as when the water has been deionised or is from an alpine supply, a high potential anode, colour coded green, should be used. The changing of anodes must be carried out by a plumber or authorised service person.

## CAUTION

If your water supply has a TDS greater than 600 mg/L and the anode has not been changed to a blue one, there is the possibility hydrogen gas could accumulate in the top of the water heater during long periods of no use.

If, under these conditions, the water heater has not been used for two or more weeks the following procedure should be carried out before using any electrical appliances (automatic washing machines and dishwashers) which are connected to the hot water supply.

The hydrogen, which is highly flammable, should be vented safely by opening a hot tap and allowing the water to flow. There should be no smoking or naked flame near the tap whilst it is turned on. Any hydrogen gas will be dissipated. This is indicated by an unusual spurting of the water from the tap. Once the water runs freely again, any hydrogen in the system will have been released. In areas where this is likely to occur, the householder should be instructed by the installer on how to dissipate the gas safely.

## SATURATION INDEX

The saturation index is used as a measure of the water's corrosive or scaling properties. In a corrosive water supply, the water can attack copper parts and cause them to fail. In a scaling water supply calcium carbonate is deposited out of the water onto any hot metallic surface. Where the saturation index is greater than +0.40, the water is scaling and an expansion control valve\* must be fitted on the cold water line after the non-return valve.

\* Refer to the [cold water connection detail on page 22](#).

**WATER HEATERS NOT INSTALLED IN ACCORDANCE WITH THE ABOVE ADVICE WILL NOT BE COVERED BY THE WARRANTY.**

# RHEEM MAINS PRESSURE WATER HEATER WARRANTY – AUSTRALIA ONLY –

## WARRANTY CONDITIONS

1. This warranty is applicable only to water heaters manufactured from 1<sup>st</sup> September 2005.
2. The water heater must be installed in accordance with the Rheem water heater installation instructions, supplied with the water heater, and in accordance with all relevant statutory and local requirements of the State in which the water heater is installed.
3. Where a failed component or water heater is replaced under warranty, the balance of the original warranty period will remain effective. The replaced part or water heater does not carry a new warranty.
4. Where the water heater is installed outside the boundaries of a metropolitan area as defined by Rheem or further than 25 km from a regional Rheem branch office, or an Accredited Service Agent, the cost of transport, insurance and travelling costs between the nearest Rheem Accredited Service Agent's premises and the installed site shall be the owner's responsibility.
5. Where the water heater is installed in a position that does not allow safe, ready access, the cost of accessing the site safely, including the cost of additional materials handling and/or safety equipment, shall be the owner's responsibility.
6. The warranty only applies to the water heater and original or genuine (company) component replacement parts and therefore does not cover any plumbing or electrical parts supplied by the installer and not an integral part of the water heater, e.g. pressure limiting valve; isolation valves; non-return valves; electrical switches; pumps or fuse.
7. The water heater must be sized to supply the hot water demand in accordance with the guidelines in the Rheem water heater literature.

## WARRANTY EXCLUSIONS

1. REPAIR AND REPLACEMENT WORK WILL BE CARRIED OUT AS SET OUT IN THE RHEEM WATER HEATER WARRANTY, HOWEVER THE FOLLOWING EXCLUSIONS MAY CAUSE THE WATER HEATER WARRANTY TO BECOME VOID AND MAY INCUR A SERVICE CHARGE AND / OR COST OF PARTS.
  - a) Accidental damage to the water heater or any component, including: Acts of God; failure due to misuse; incorrect installation; attempts to repair the water heater other than by a Rheem Accredited Service Agent or the Rheem Service Department.
  - b) Where it is found there is nothing wrong with the water heater; where the complaint is related to excessive discharge from the temperature and / or pressure relief valve due to high water pressure; where there is no flow of hot water due to faulty plumbing; where water leaks are related to plumbing and not the water heater or water heater components; where there is a failure of gas, electricity or water supplies; where the supply of gas, electricity or water does not comply with relevant codes or acts.
  - c) Where the water heater or water heater component has failed directly or indirectly as a result of: excessive water pressure; excessive temperature and / or thermal input; blocked overflow / vent drain; corrosive atmosphere; ice formation in the pipe work to or from the water heater.
  - d) Where the solar water heater or solar water heater component has failed directly or indirectly as a result of ice formation in the water ways of a solar water heater system; without a freeze protection system; with a freeze protection system where the electricity supply has been switched off or has failed; (Hiline) installed at an altitude more than 600 metres above sea level; (Loline) installed at an altitude more than 800 metres above sea level; where the system has not been installed in accordance with the water heater installation instructions.
  - e) Where the water heater is located in a position that does not comply with the Rheem water heater installation instructions or relevant statutory requirements, causing the need for major dismantling or removal of cupboards, doors or walls, or use of special equipment to bring the water heater to floor or ground level or to a serviceable position.
  - f) Repair and / or replacement of the water heater due to scale formation in the waterways or the effects of corrosive water when the water heater has been connected to a scaling or corrosive water supply as outlined in the Owner's Guide and Installation Instructions booklet.
  - g) Breakage of collector glass for any reason including hail damage. (We suggest that the collector glass be covered by your home insurance policy).
2. SUBJECT TO ANY STATUTORY PROVISIONS TO THE CONTRARY, THIS WARRANTY EXCLUDES ANY AND ALL CLAIMS FOR DAMAGE TO FURNITURE, CARPETS, WALLS, FOUNDATIONS OR ANY OTHER CONSEQUENTIAL LOSS EITHER DIRECTLY OR INDIRECTLY DUE TO LEAKAGE FROM THE WATER HEATER, OR DUE TO LEAKAGE FROM FITTINGS AND / OR PIPE WORK OF METAL, PLASTIC OR OTHER MATERIALS CAUSED BY WATER TEMPERATURE, WORKMANSHIP OR OTHER MODES OF FAILURE.

# RHEEM MAINS PRESSURE WATER HEATER WARRANTY – AUSTRALIA ONLY –

## WARRANTY

Rheem will:

- a) Repair or, if necessary replace any Rheem water heater; or
- b) Replace any component (or, if necessary, arrange the installation of a new water heater), which falls within the Warranty Periods specified below, subject to the warranty conditions and exclusions.

Installation	Model	Period	Warranty
<b>All Components (from date of installation)</b>			
All installations	All models	Year 1	New component or water heater (at Rheem's sole discretion), free of charge, including labour.**
<b>Sealed System * (from date of installation)</b>			
Water heater installed in a "single-family domestic dwelling with a thermostat setting below 76°C"	Heat Pump	Year 2	New sealed system component, free of charge, including labour.**
<b>Cylinder and SuperFlue (from date of installation)</b>			
Water heater installed in a "single-family domestic dwelling with a thermostat setting below 76°C"	Rheemglas	Years 2 & 3	New water heater, free of charge, including labour.**
	RheemPlus		
	Loline	Years 4 & 5	New water heater, free of charge, with installation and labour costs being the responsibility of the owner.
	Hiline		
Heat Pump	Stellar	Years 2 to 5	New water heater, free of charge, including labour.**
	Optima		
Water heater installed in any other than a "single-family domestic dwelling with a thermostat setting below 76°C"	Heavy Duty	Years 6 to 10	New water heater, free of charge, with installation and labour costs being the responsibility of the owner.
	Rheemglas	Years 2 & 3	New water heater, free of charge, with installation and labour costs being the responsibility of the owner.
	RheemPlus		
	Loline	Years 2 to 5	New water heater, free of charge, with installation and labour costs being the responsibility of the owner.
Hiline			
Heat Pump	Stellar	Years 2 to 5	New water heater, free of charge, with installation and labour costs being the responsibility of the owner.
	Optima		
	Heavy Duty		
<b>Solar Collector (from date of installation)</b>			
All installations	SCT200 SBT200 NPT200	Years 2 to 5	New solar collector, free of charge, with installation and labour costs being the responsibility of the owner.

### Notes:

\* The Sealed System includes components that carry refrigerant only, e.g. Compressor, Condenser, TX Valve, Receiver/Drier, Evaporator and associated pipe work.

\*\* Refer to items 4 and 5 of warranty conditions.

Rheem reserves the right to transfer fully functional components from the defective water heater to the replacement water heater if required. The term "water heater" used in the Warranty, Warranty Conditions and Warranty Exclusions means the Rheem supplied water heater(s), solar storage tank(s), solar collector(s), kit(s) and components.

In addition to this warranty, the Trade Practices Act 1974 and similar laws in each state and territory provide the owner under certain circumstances with certain minimum statutory rights in relation to your Rheem water heater. This warranty must be read subject to that legislation and nothing in this warranty has the effect of excluding, restricting or modifying those rights.

**RHEEM AUSTRALIA PTY LTD**  
A.B.N. 21 098 823 511  
www.rheem.com.au

**FOR SERVICE TELEPHONE**  
**131 031 AUSTRALIA**  
**0800 657 335 NEW ZEALAND**  
or refer local Yellow Pages

NOTE: Every care has been taken to ensure accuracy in preparation of this publication. No liability can be accepted for any consequences, which may arise as a result of its application. 122001B



## Free Manuals Download Website

<http://myh66.com>

<http://usermanuals.us>

<http://www.somanuals.com>

<http://www.4manuals.cc>

<http://www.manual-lib.com>

<http://www.404manual.com>

<http://www.luxmanual.com>

<http://aubethermostatmanual.com>

Golf course search by state

<http://golfingnear.com>

Email search by domain

<http://emailbydomain.com>

Auto manuals search

<http://auto.somanuals.com>

TV manuals search

<http://tv.somanuals.com>