



# 1540

## Rear Mounted Blade

Rev 03-07

Part No. 697P

# PART'S MANUAL



An Operator's Manual was shipped with the equipment in the Manual Canister. This Operator's Manual is an integral part of the safe operation of this machine and must be maintained with the unit at all times. **READ, UNDERSTAND, and FOLLOW** the Safety and Operation Instructions contained in this manual before operating the equipment. If the Operator's Manual is not with the equipment, contact your dealer or Servis-Rhino (800-446-5158) to obtain a Free copy before operating the equipment.

## ATENCIÓN!

LEA EL INSTRUCTIVO

Si No Lee Ingles, Pida Ayuda a Alguien Que Si Lo Lea Para Que le Traduzca las Medidas de Seguridad.

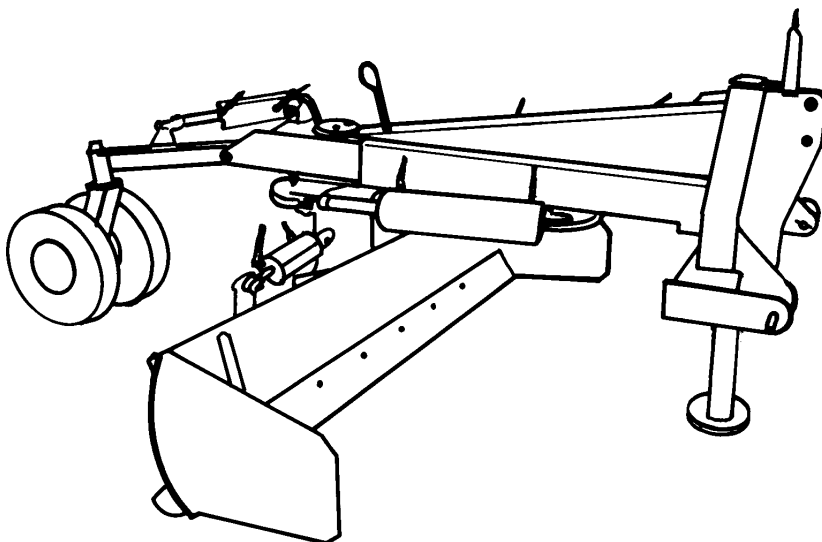

## RHINO®

1020 S. Sangamon Ave.  
Gibson City, IL 60936  
800-446-5158

Email: [parts@servis-rhino.com](mailto:parts@servis-rhino.com)

© 2007 Alamo Group Inc.



# TO THE OWNER/OPERATOR/DEALER

All implements with moving parts are potentially hazardous. There is no substitute for a cautious, safe-minded operator who recognizes the potential hazards and follows reasonable safety practices. The manufacturer has designed this implement to be used with all its safety equipment properly attached to minimize the chance of accidents.

**BEFORE YOU START!!** Read the safety messages on the implement and shown in your manual.  
Observe the rules of safety and common sense!



# DANGER

FAILING TO FOLLOW SAFETY MESSAGES AND OPERATING INSTRUCTIONS CAN CAUSE SERIOUS BODILY INJURY OR EVEN DEATH TO OPERATOR AND OTHERS IN THE AREA.

<p>1.</p>	<p>2. NO RIDERS, NO CHILDREN OPERATORS</p>	<p>3. USE SAFETY SHOES, HARD HAT, SAFETY GLASSES, SEATBELTS, &amp; ROPS</p>	<p>4. BLOCK UP SECURELY BEFORE WORKING UNDER.</p>
-----------	--	---	---

- Study and understand Operator's Manuals, Safety Signs, and Instructional Decals for tractor & flail mower to prevent misuse, abuse, & accidents. Practice before operating mower in a confined area or near passersby.
  - Learn how to stop engine suddenly in an emergency. Be alert for passersby and especially children.
- Allow no children on or near implement or tractor. Allow no riders on tractor or implement. Falling off can cause serious injury or death from being runover by tractor or mower or contact with Flail Mower Blades.
- Operate only with tractor having Roll-Over Protective Structure (ROPS) and with seatbelt fastened securely and snugly to prevent injury and possible death from falling off or tractor overturn. Personal Protective Equipment such as Hard Hat, Safety Glasses, Safety Shoes, and Ear Plugs are recommended.
- Block up or support raised machine and all lifted components securely before putting hands or feet under or working underneath any lifted component to prevent crushing injury or death from sudden dropping or inadvertent operation of controls. Make certain that area is clear before lowering or folding.
- Before transporting, put Lift Lever in detent or full-lift position. Install Transport Safety Devices securely on folding implements. Slow down when turning and on hillsides.
  - Install \*\*Restrictor in folding circuit to slow down lowering and unfolding if action is faster than is desirable.
- Make certain that SMV sign, Warning Lights, and Reflectors are clearly visible. Follow local traffic codes.
- Never operate with Flail Mower or Folding Section raised if passersby, bystanders or traffic are in the area to reduce possibility of injury or death from objects thrown by Blades under Shields or implement structure.
- Before dismounting, secure flail mower in transport position or lower to ground.
  - Put tractor in park or set brake, disengage PTO, stop engine, remove key, and wait until noise of rotation has ceased to prevent entanglement in rotating parts which may cause injury or death.
  - Never mount or dismount a moving vehicle. Crushing from runover may cause injury or death.

<p>5. TRANSPORT SAFELY, LOCK UP.</p> <p>WARRANTY INFORMATION</p>	<p>6. USE SMV, LIGHTS, &amp; REFLECTORS.</p>	<p>7. DO NOT OPERATE WITH MOWER OR WING RAISED.</p>	<p>8. DO NOT MOUNT OR DISMOUNT WHILE MOVING.</p> <p>002369</p>
--	--	---	--

Read and understand the complete Warranty Statement found in this Manual. Fill out the Warranty Registration Form in full and return it within 30 Days. Make certain the Serial Number of the Machine is recorded on the Warranty Card and on the Warranty Form that you retain. The use of "will-fit" parts will void your warranty and can cause catastrophic failure with possible injury or death.

# **PARTS SECTION**

# PARTS ORDERING GUIDE

The following instructions are offered to help eliminate needless delay and error in processing purchase orders for the equipment in this section.

1. The Parts Section is prepared in logical sequence and grouping of parts that belong to the basic machine featured in this manual. Part Numbers and Descriptions are given to help locate the parts and quantities required.
2. The Purchase Order must include the name and address of the person or organization ordering the parts, who should be charged, and if possible, the serial number of the machine for which the parts are ordered.
3. The Purchase Order must clearly list the quantity of each part, the complete and correct part number (be sure to include all periods), and the basic name of the part.
4. The Manufacturer reserves the right to substitute parts where applicable.
5. Some parts are unlisted items which are special production items not normally stocked and are subject to special handling. Request a quotation for such parts before sending a Purchase Order.
6. The Manufacturer reserves the right to change prices without prior notice.

**NOTE:** Please refer to The Safety Section in the front of this Manual for the proper Part Number when ordering Replacement Safety Decals.



For maximum safety and to guarantee optimum product reliability, always use genuine Servis-Rhino Parts. The use of inferior replacement parts may cause premature or catastrophic failure which could result in serious injury or death. Direct any questions regarding parts to:



**RHINO®**  
1020 S. Sangamon Ave.  
Gibson City, IL 60936  
800-446-5158  
Email: [parts@servis-rhino.com](mailto:parts@servis-rhino.com)

# PART NAME INDEX

ADJUST LINK ASSEMBLY .....	27, 28
ADJUSTING LINK - MANUAL .....	29, 30
BRACKET ASSY - CONTROL VALVE.....	23
CONTROL VALVE ASSEMBLY .....	24
CYLINDER - HYDRAULIC.....	14, 15, 17, 18, 19, 20, 21
CYLINDER - HYDRAULIC Rev 03-07.....	13
GAUGE WHEEL .....	7
GENERAL ASSEMBLY Rev 03-07 .....	4
HOSE CONNECTIONS - HYDRAULIC.....	22
HYDRAULIC CYLINDER .....	16
HYDRAULIC CYLINDER Rev 03-05 .....	12
REAR BLADE HYDRAULICS.....	11
SAFETY DECAL SHEETS .....	31
SKID SHOE ASSEMBLY S/N 16152-CURRENT Rev 03-07.....	6
VALVE SELECTOR .....	26
WHEEL HUB.....	9, 10
WHEEL HUB ASSEMBLY .....	8

# GENERAL ASSEMBLY Rev 03-07

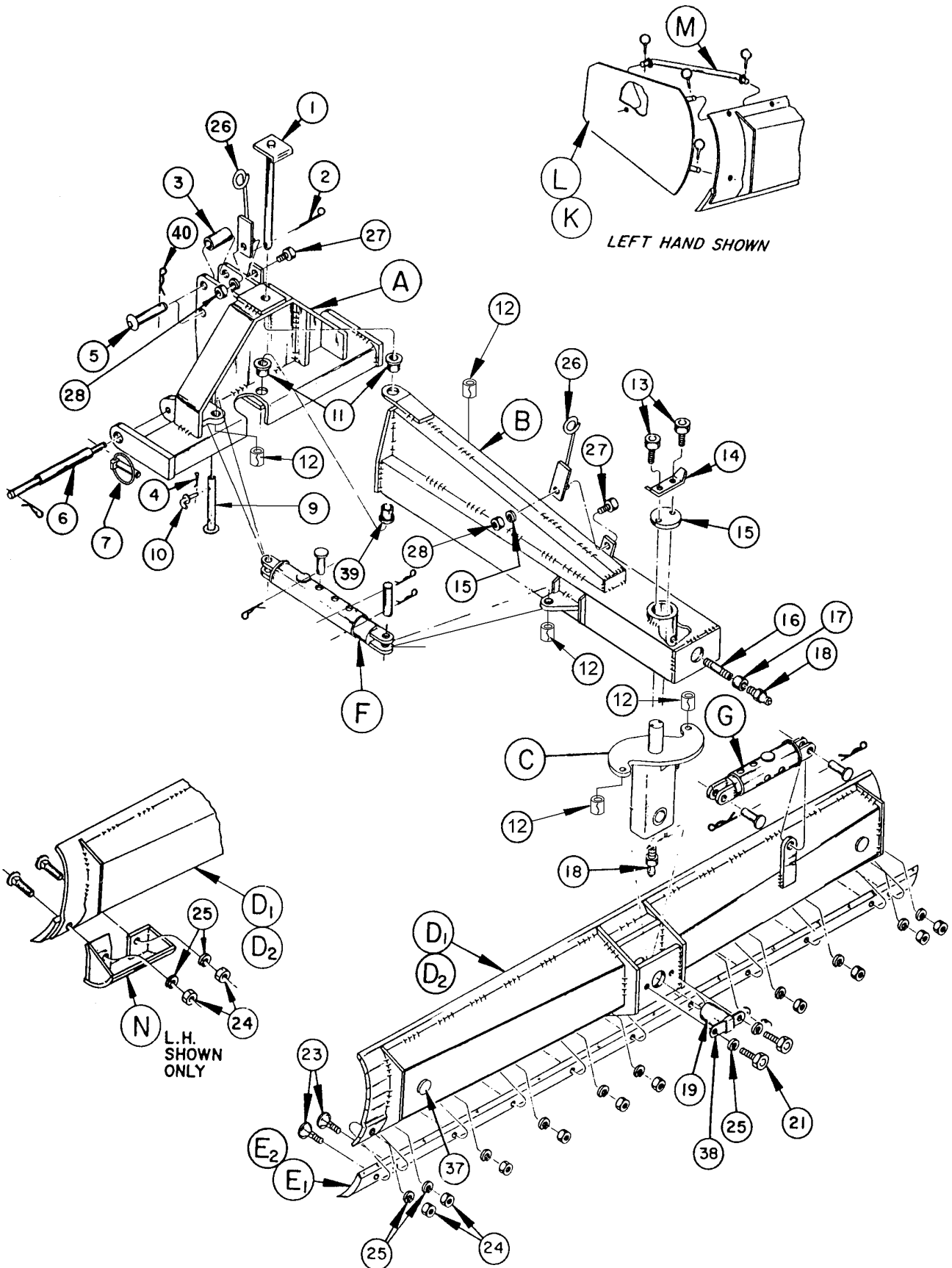

1540 (Oct-01)S/N 14500 -Current Rev 03-07

©2007 Alamo Group Inc.

Parts Section - 4

Download from [www.Somanuals.com](http://www.Somanuals.com). All Manuals Search And Download.

# GENERAL ASSEMBLY Rev 03-07

ITEM	PART NO.	QTY.	DESCRIPTION
A	00775902	1	A-FRAME
B	00775901	1	MAINFRAME
C	00775900	1	MOLDBOARD CARRIER
D1	69104B1	1	MOLDBOARD (8')
D2	69137B1	1	MOLDBOARD (10')
E1	441111	1	GRADER BLADE (8')
E2	691372	1	GRADER BLADE (10')
F	B69115A	2	ADJUSTING LINK
G	B69116B	1	ADJUSTING LINK
K	0691360200	1	END PLATE (RIGHT)
L	0691360300	1	END PLATE (LEFT)
M	0691360100	2	BRACE, END PLATE
	0691360001	8	LOCKING PIN
N	0691380000	2	SKID SHOE W/HARDWARE (16151 -BELOW)
	2A3101120	4	PLOW BOLT (16151-BELOW)
1	69105A	1	PIVOT PIN
2	164024	1	COTTER PIN
3	69113	1	TOP LINK BUSHING
4	2192	1	HAIR PIN COTTER
5	69109	1	TOP LINK PIN
6	69141	2	WRIST PIN
7	2196	4	PIN, LYNCH
9	0831140000	1	SUPPORT STAND
10	69112	1	LOCK PIN
11	6910114	2	BUSHING
12	0692010009	5	BUSHING (FOR USE WITH ALL 1" PIN CYLINDERS AND ADJ. LINKS)
	02969064	5	BUSHING (FOR USE WITH ALL 1 1/4" PIN CYLINDERS)
13	02929200	2	BOLT
14	69117	1	RETAINER CLIP
15	69110	1	KING PIN CAP
16	19C1220	1	NIPPLE
17	8639-2	1	COUPLING
18	4720	2	GREASE FITTING
19	69106	1	MOLDBOARD PIVOT PIN WELDMENT
21	02675800	2	BOLT
23	2A3101116	10*	PLOW BOLT
24	00010400	10*	NUT (16151 -BELOW)
25	00010300	12*	LOCKWASHER (16151 -BELOW)
26	0691320000	2	HYDRAULIC HOSE BRACKET ASSY
27	02675800	2	BOLT
28	00695100	2	NUT, TOPLOCK
38	69111	1	RETAINER
39	0831010008	1	BUSHING LOWER MAINFRAME
40	0691360001	1	PIN, KCLICK 1/4 X 1-3/4

\* Add 2 for 10' Moldboard

# SKID SHOE ASSEMBLY S/N 16152-CURRENT Rev 03-07

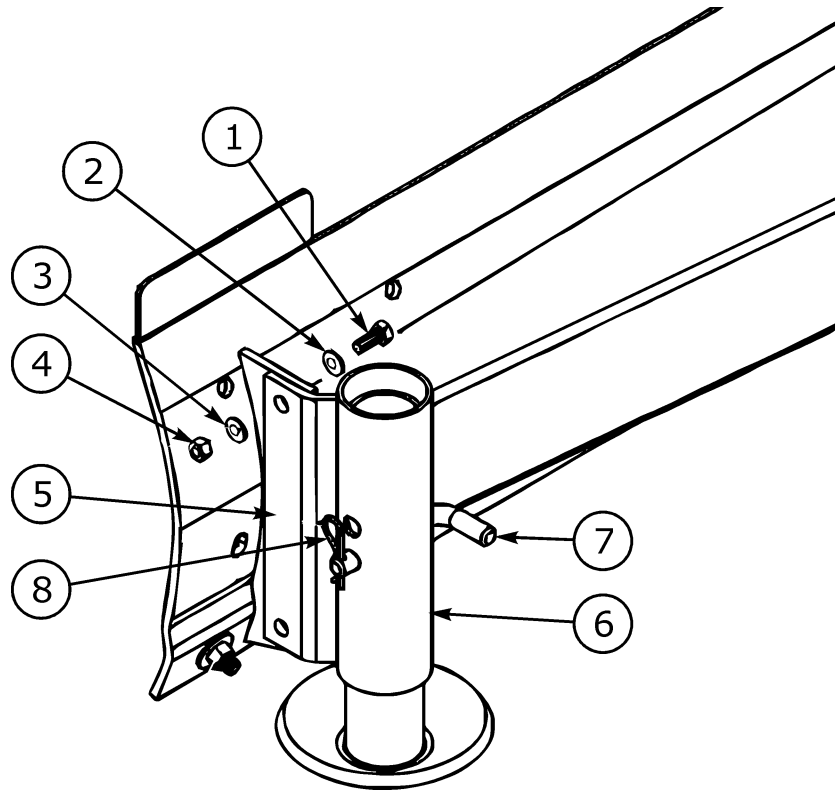

ITEM	PART NO.	QTY.	DESCRIPTION
1	02845500	4	HEXB 5/8 NC 2 PL5
2	00001401	4	WASHER
3	00010300	4	LOCKWASHER 5/8
4	00010400	4	NUT 5/8 NC HEX PL
5	00768246	2	WELDMENT, SKID SHOE MOUNT
6	00768243	2	WELDMENT, SKID SHOE
7	00768249	2	PIN, ADJUSTING
8	37107B13	2	CLIP-X HAIR PIN



# GAUGE WHEEL

## SECTION "A"

00758151  
Use Hub Assy  
P/N 00756489\*

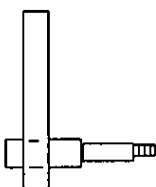

0771040200  
Use "M" Hub Group

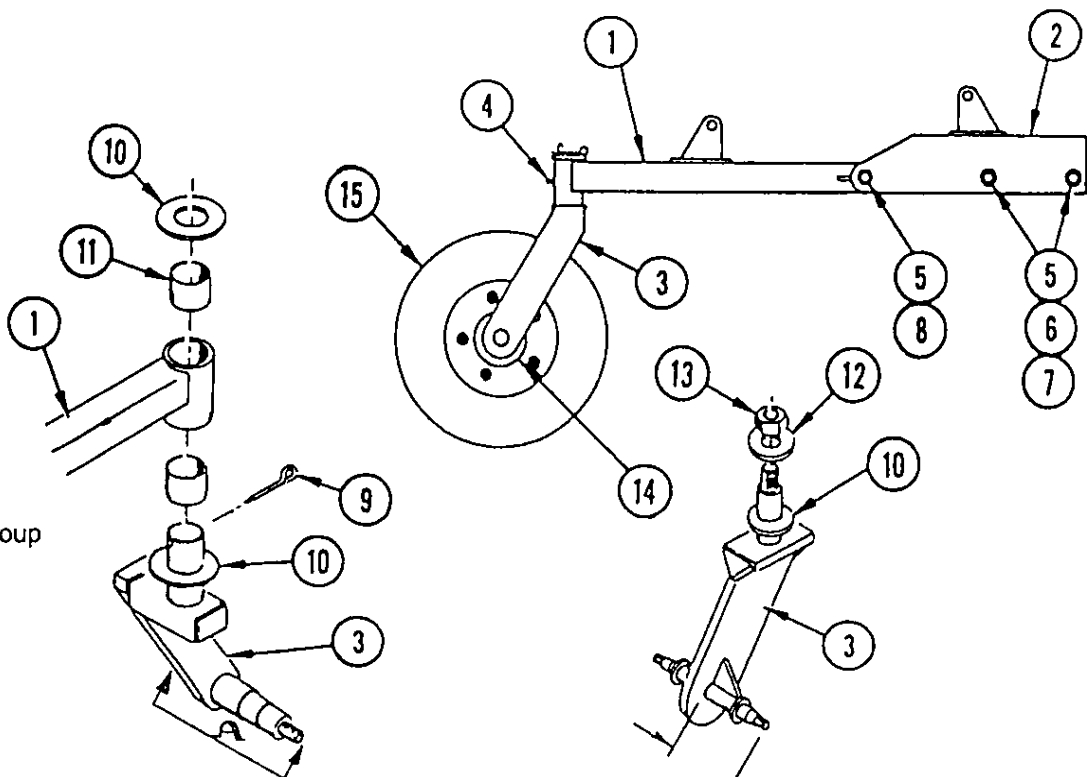
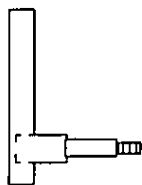

9-7/16" P/N 00758554  
(Use Hub P/N 00756489\*)  
7-13/16" P/N 0831080310  
(Use "H" Hub Group)

ITEM	PART NO.	QTY.	DESCRIPTION
1	0831080200	1	BEAM WELDMENT W/BUSHINGS
2	0691500100	1	TAILWHEEL BRACKET
3	00758151	1	CASTER WLDMT (SINGLE SPINDLE)
	00758554	1	CASTER WLDMT (DOUBLE SPINDLE)
4	4720	1	GREASE FITTING
5	7A121080	3	BOLT
6	00003901	2	LOCKWASHER
7	5B12100	2	NUT
8	5GR12100	1	LOCKNUT
9	165024	1	COTTER PIN (SINGLE SPINDLE)
10	301042	2	THRUST WASHER
11	54103A11	2	PIVOT BUSHING
12	59113	1	WASHER
13	5JRA2460	1	NUT (DOUBLE SPINDLE)
14	00756489	1	HUB ASSEMBLY
15	00025200	1	PUNCTURE PROOF TIRE & WHEEL

# WHEEL HUB ASSEMBLY

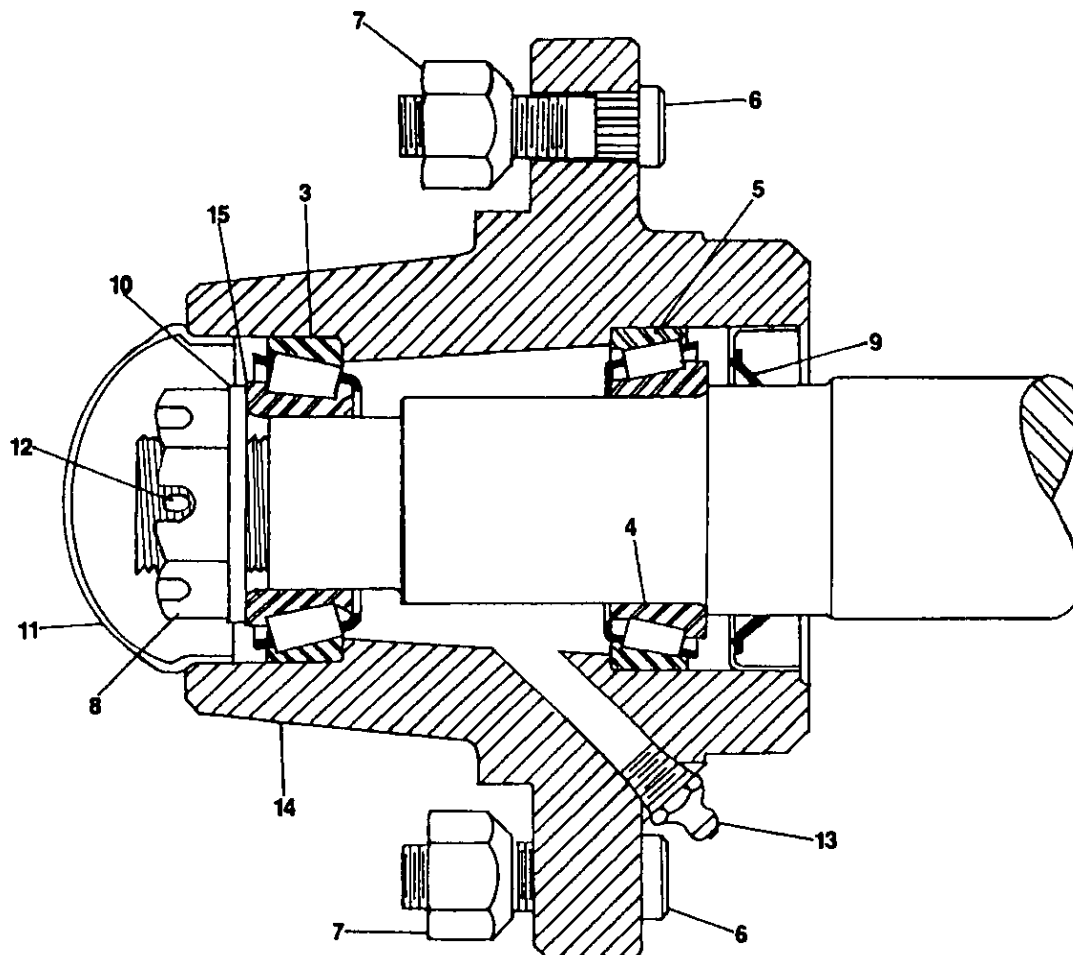

ITEM	PART NO.	QTY.	DESCRIPTION
3	00756576	1	BEARING CUP(OUTSIDE)
4	00750434	1	BEARING CONE(INSIDE)
5	00756577	1	BEARING CUP(INSIDE)
6	00756488	5	STUD BOLT
7	00750614	5	NUT
8	00756490	1	BEARING ADJUSTING NUT
9	00756491	1	SEAL
10	00756493	1	WASHER
11	00756492	1	DUST CAP
12	00000400	1	COTTER PIN
13	00003500	1	GREASE FITTING
14	00756000	1	WHEEL HUB
15	0371242102	1	BEARING CONE(OUTSIDE)
16	00756001	ref	SPINDLE, SINGLE WHEEL
	00756489	ref	HUB(W/CUPS & STUDS)
	00756528	ref	WHEEL HUB ACCESSORY KIT
17	00756002	ref	SPINDLE, DUAL WHEEL

1540 (Oct-01)S/N 14500 -Current Rev 03-07

# WHEEL HUB

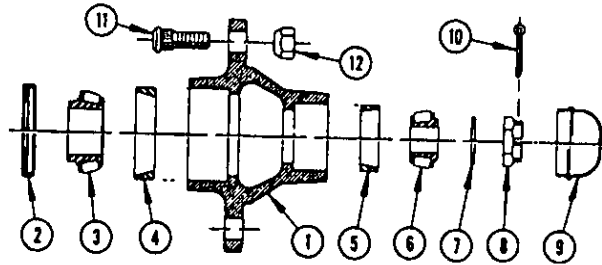

**NOTE** Used with Dual Gauge Wheel Only!

ITEM	PART NO.	QTY.	DESCRIPTION
1	371247SA	1	HUB ASSEMBLY (INCL. 4, 5, 11, 12)
2	371247F	1	GREASE SEAL
3	371247E	1	BEARING CONE (INNER)
4	371247D	1	BEARING CUP (INNER)
5	W-33	1	BEARING CUP (OUTER)
6	371247C	1	BEARING CONE (OUTER)
7	371247H	1	SPINDLE WASHER
8	371247J	1	SPINDLE NUT
9	1621/2010	1	COTTER PIN
10	371247G	1	HUB CAP
11	PT115	5	LUG BOLT
12	PT116	5	LUGNUT

# WHEEL HUB

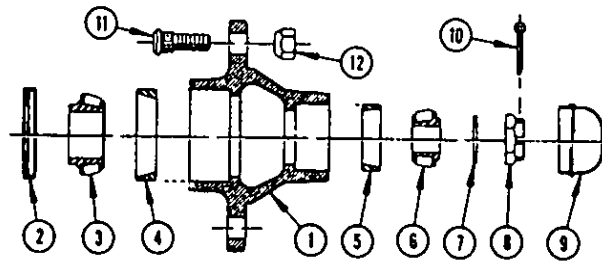

**NOTE** Used with Single Gauge Wheel Only!

ITEM	PART NO.	QTY.	DESCRIPTION
1	PT110SA	1	HUB ASSEMBLY (INCL. 4, 5, 11, 12)
2	PT106	1	GREASE SEAL
3	PT107	1	BEARING CONE (INNER)
4	W-33	1	BEARING CUP (INNER)
5	PT108	1	BEARING CUP (OUTER)
6	PT109	1	BEARING CONE (OUTER)
7	PT113A	1	SPINDLE WASHER
8	PT114	1	SPINDLE NUT
9	1621/2010	1	COTTER PIN
10	PT112	1	HUB CAP
11	PT115	5	LUG BOLT
12	PT116	5	LUGNUT

# REAR BLADE HYDRAULICS

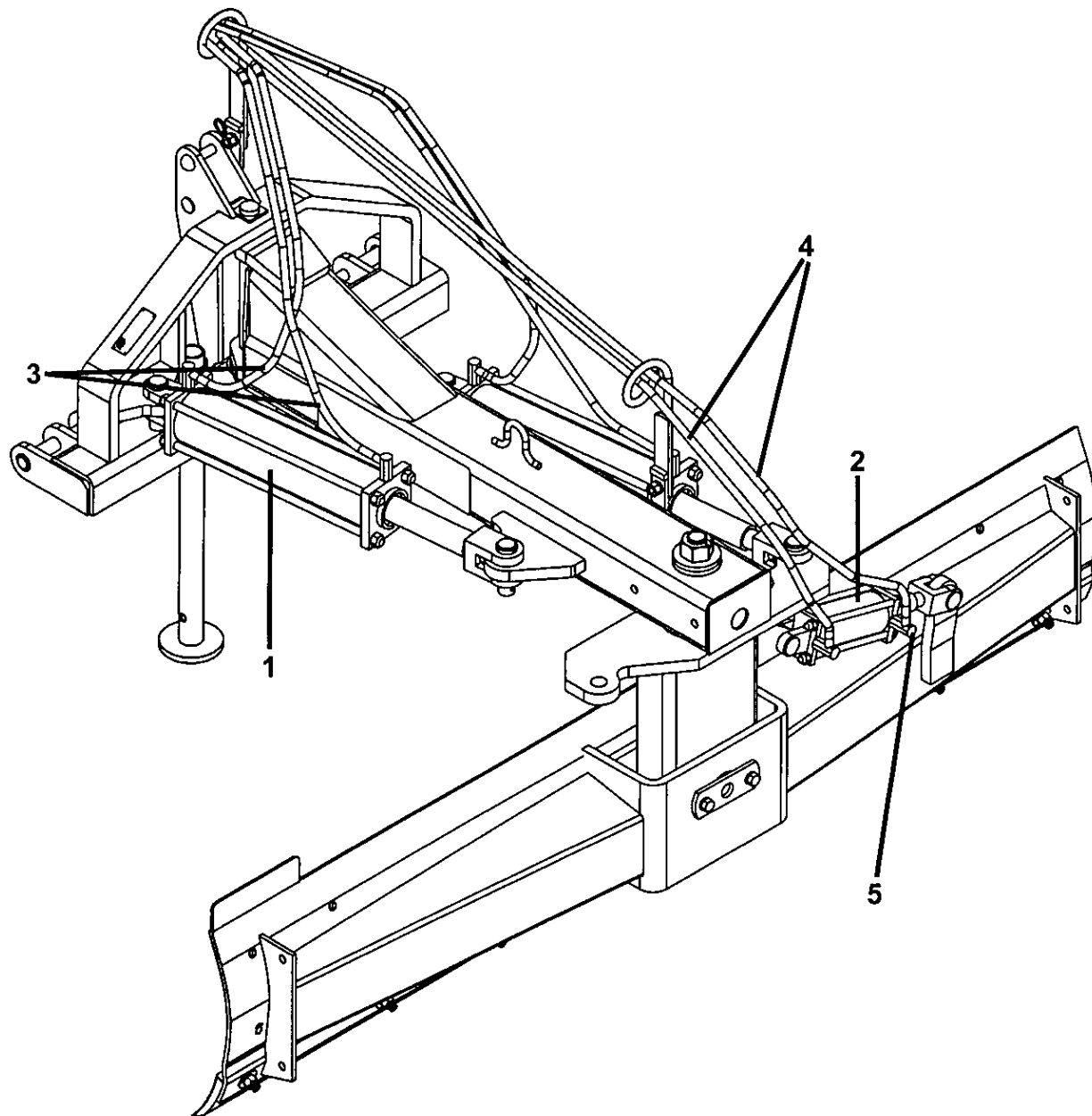

ITEM	PART NO.	QTY 8'	QTY 10'	DESCRIPTION
1	0691600000B	1	2	HYDRAULIC CYLINDER
2	00759715A	1	1	HYDRAULIC CYLINDER
3	691302	2	4	HOSE
4	651132	2	2	HOSE
5	11565	2	4	ELBOW ADAPTER

# HYDRAULIC CYLINDER Rev 03-05

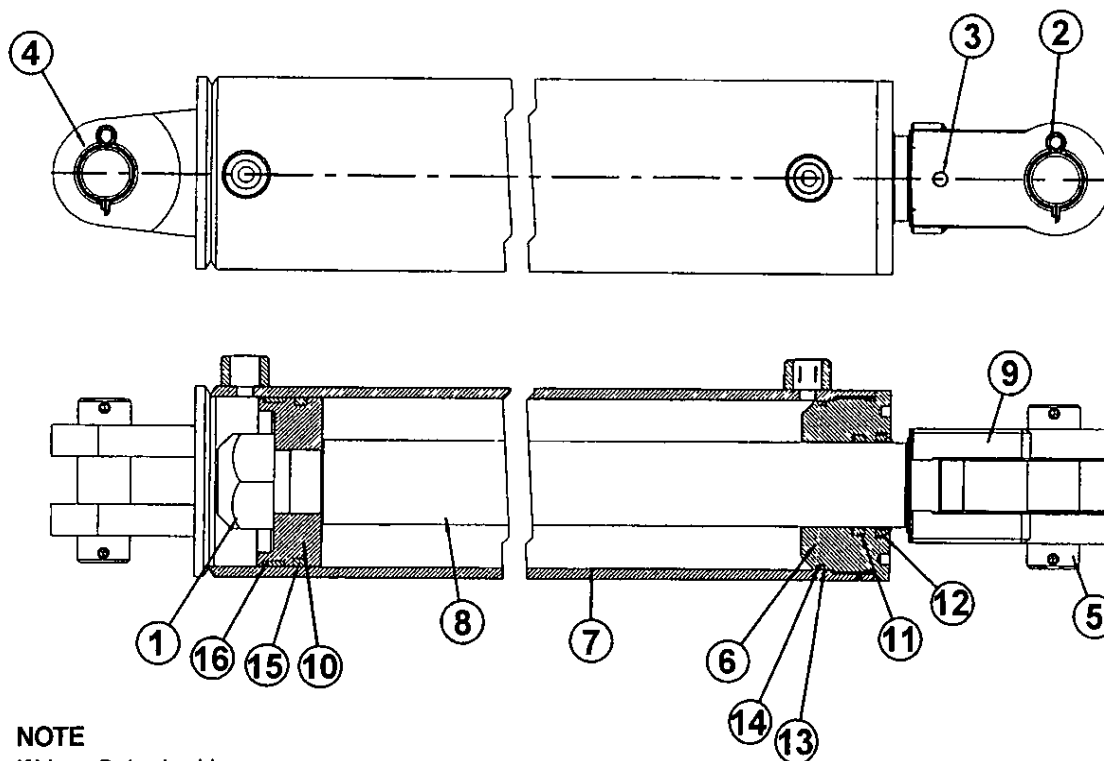

**NOTE**  
 If Your Cylinder Uses  
 1-1/4" pin use Seal Kit  
 P/N 02975527

ITEM	PART NO.	QTY.	DESCRIPTION
	<b>0691600000B</b>	-	<b>HYDRAULIC CYLINDER</b>
1	00775917	1	HEX NUT
2	49045	4	COTTER PIN
3	0116000	1	SETSCREW
4	00775918	4	BUSHING
5	00775916	2	CYLINDER PIN
6	00775915	1	CYLINDER HEAD
7	00778736	1	CYLINDER TUBE
8	00775913	1	CYLINDER ROD
9	00775912	1	ROD CLEVIS
10	00775911	1	PISTON
11	α*	1	SEAL HALLITE
12	α*	1	SEAL WIPER ROD
13	α*	1	SEAL
14	α*	1	O-RING
15	α*	1	SEAL PSP PISTON RING
16	α*	1	WEAR RING
17	00775908	4	HYDRAULIC HOSE
*	02975527	Ref	SEAL KIT

# CYLINDER - HYDRAULIC Rev 03-07

OBSOLETE - FOR REPLACEMENT PARTS ONLY

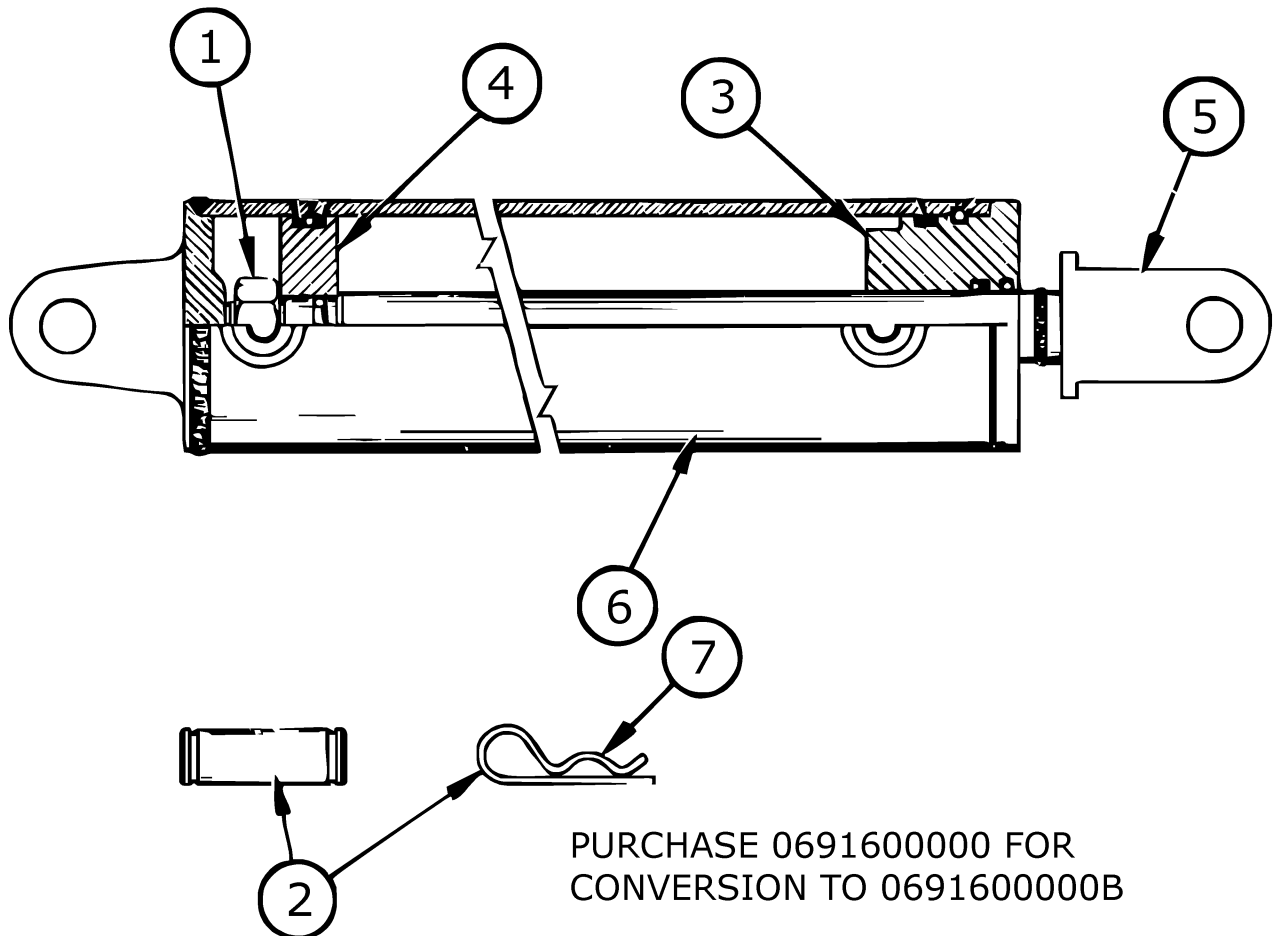

ITEM	PART NO.	QTY.	DESCRIPTION
	<b>0691600000</b>	-	<b>CYLINDER HYD 16 STX4BOREX2ROD</b>
1	0781070002	1	LOCKNUT PISTON
2	0781070013	2	PIN, CLEVIS
3	0781070014	1	HEAD
4	0781070015	1	PISTON
5	0691600016	1	ROD,PISTON W/CLEVIS
6	0691000100	1	BARREL,HYD.CYLINDER
7	37107B13	2	CLIP-X HAIR PIN
	0781070200	-	SEAL KIT

# CYLINDER - HYDRAULIC

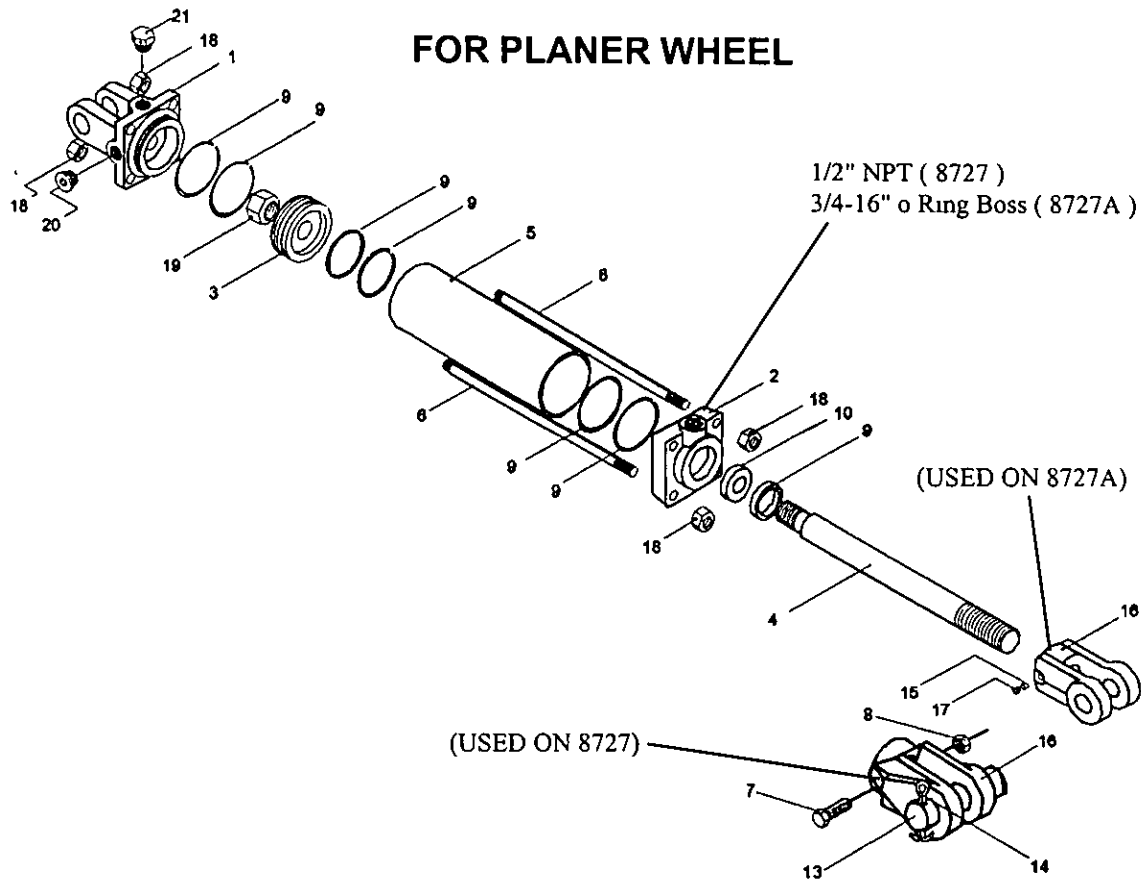

ITEM	PART NO.	QTY.	DESCRIPTION
	<b>8727</b>		<b>COMPLETE ASSEMBLY</b>
1	8755	1	CAP
2	8757	1	HEAD
3	00760671	1	PISTON
4	8753	1	PISTON ROD
5	8752	1	TUBE
6	8756	4	TIE ROD
7	00023100	1	BOLT
8	00013901	1	HEX NUT
9	8763	1	SEAL KIT
13	8354	2 ref	PIVOT PIN
14	00606000	2 ref	COTTER PIN
16	8754	1	OUTER CLEVIS
18	02031800	8	TIE ROD NUT
19	4675	1	PISTON NUT
21	7339	1	BREATHER PLUG
	651132	2 ref	HYDRAULIC HOSE (NOT SHOWN)
	94514	2 ref	SWIVEL FITTING 90 DEGREES (NOT SHOWN)



# CYLINDER - HYDRAULIC

## FOR PLANER WHEEL

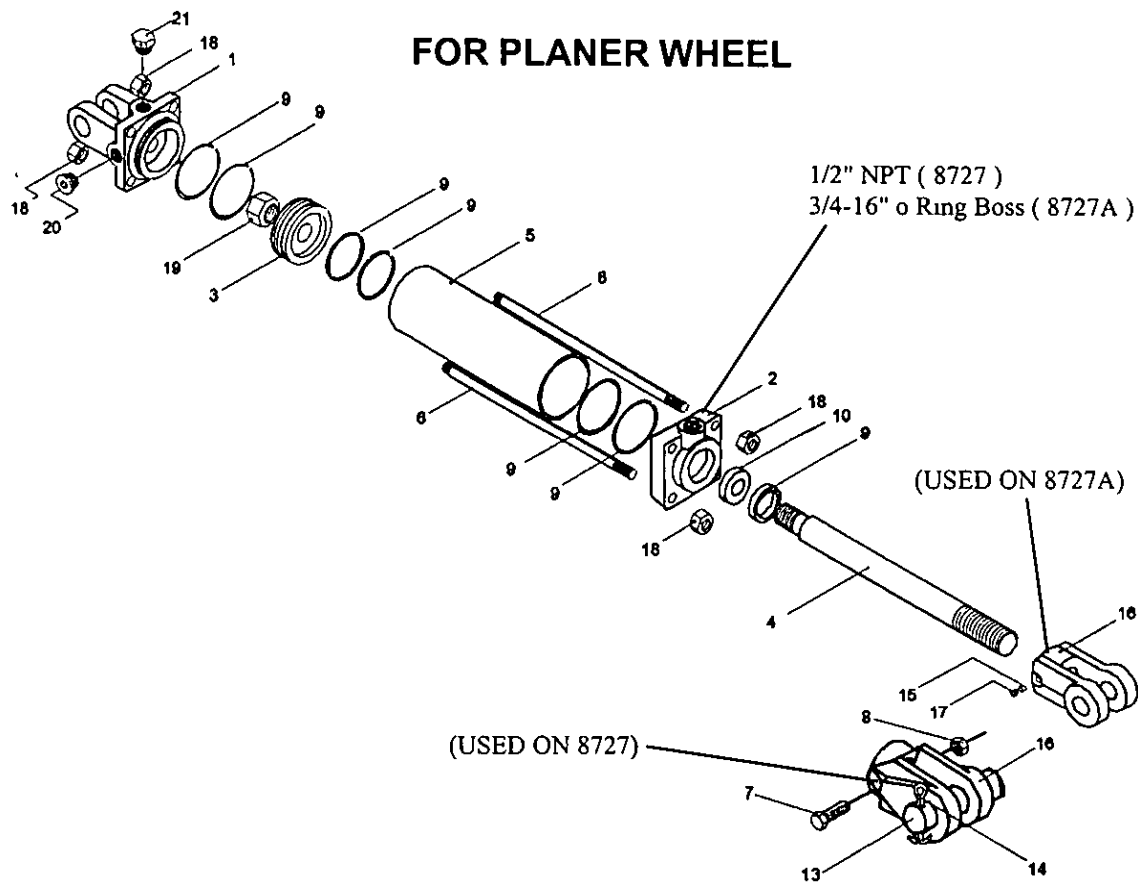

ITEM	PART NO.	QTY.	DESCRIPTION
	<b>8727A</b>		<b>COMPLETE ASSEMBLY</b>
1	00774729	1	CLEVIS CAP
2	00774734	1	ROD CAP
3	00774730	1	PISTON
4	00774753	1	ROD
5	3047111	1	TUBE
6	3047112	4	TIE ROD
15	3047117	1	NYLON THREAD PROTECTOR
16	1917140	1	ROD CLEVIS
17	00774740	1	SET SCREW
18	33003H5C	8	TIE ROD NUT
19	5JRC12160	1	PISTON NUT
20	1917132	1	PORT PLUG
21	2417154	1	BREATHER
	00774700	1*	SEALANT (NOT SHOWN)
	651132	2*	HOSE (NOT SHOWN)
	94514	2*	ELBOW (NOT SHOWN)
	0652141311	2*	ADAPTER (NOT SHOWN)
	8354	2*	PIN (NOT SHOWN)
	00606000	2*	COTTER PIN (NOT SHOWN)
*	00774760	-	SEAL KIT FOR 8727A CYL

# HYDRAULIC CYLINDER

DISCONTINUED  
FOR REPLACEMENT  
PARTS ONLY

## MOLDBOARD TILT

SERIAL NUMBER  
10928 THRU 14499

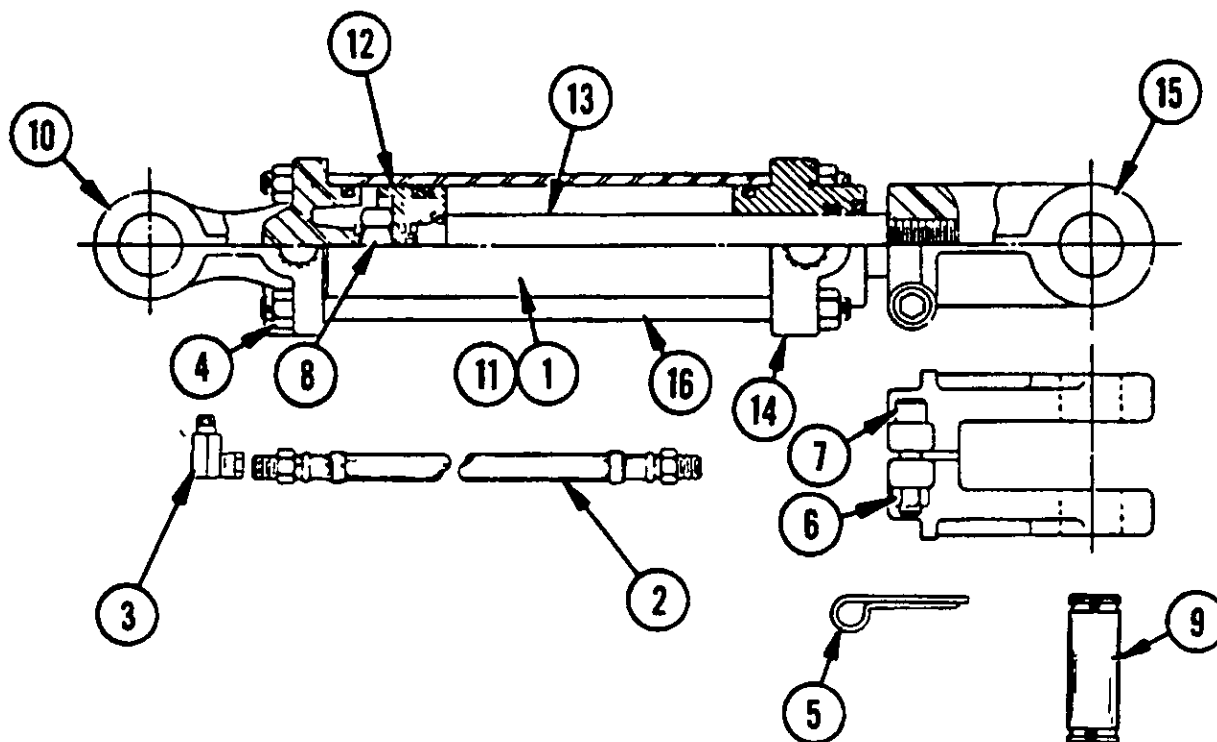

ITEM	PART NO.	QTY.	DESCRIPTION
	<b>00759715A</b>	-	<b>HYDRAULIC CYLINDER</b>
1	2417158	1	CLEVIS CAP
2	2417157	1	ROD CAP
3	00774733	1	PISTON
4	00774736	1	ROD
5	00774747	1	TUBE
6	00774741	4	TIE ROD
7	α*	2	END CAP O-RING
8	α*	1	ROD, WIPER SEAL
9	α*	1	ROD, DUST SEAL
10	α*	1	PISTON SEAL
11	α*	2	PISTON WEAR RING
12	α*	2	END CAP BACKUP WASHERS
13	3047117	1	NYLON THREAD PROTECTOR
14	1917140	1	ROD CLEVIS
15	00774740	1	SET SCREW
16	33005H5C	8	TIE ROD NUT
17	5JRC16140	1	PISTON NUT
18	1917132	1	PORT PLUG
19	11565	2	ELBOW, FITTING 90DEGREES
20	651132	2	HYDRAULIC HOSE
*	02975527	-	SEAL KIT

# CYLINDER - HYDRAULIC

FOR GAUGE WHEEL

**DISCONTINUED**  
FOR REPLACEMENT  
PARTS ONLY

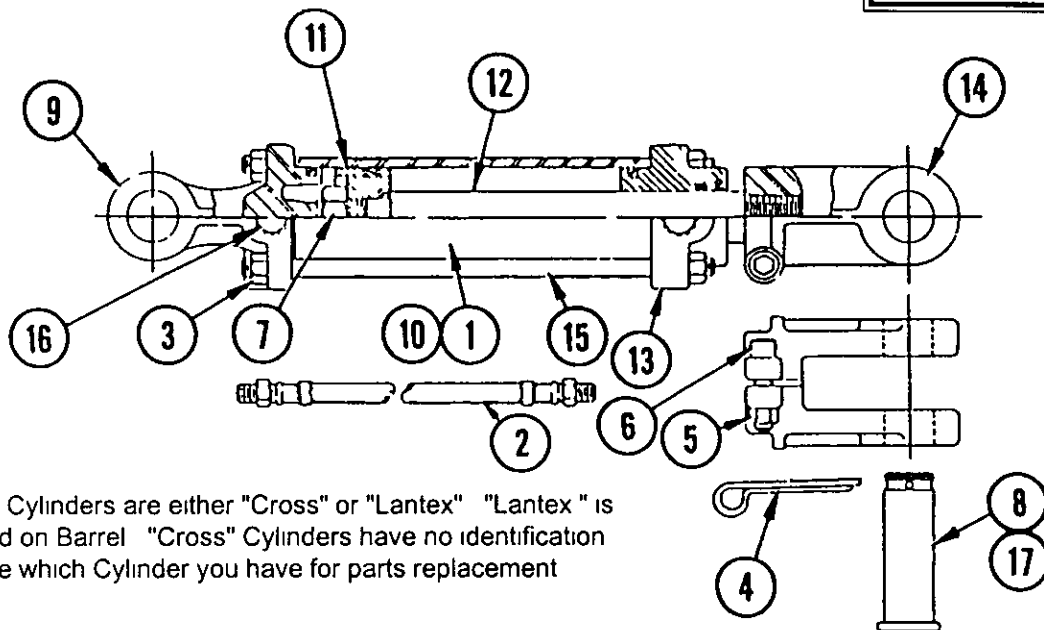

**NOTE** Cylinders are either "Cross" or "Lantex" "Lantex" is stamped on Barrel "Cross" Cylinders have no identification Observe which Cylinder you have for parts replacement

OLD STYLE - 3" BORE

ITEM	PART NO.	QTY.	DESCRIPTION
1	00759715	1	HYDRAULIC CYLINDER W/CLEVIS PIN
2	691302	1	HYDRAULIC HOSE
3	94514	1	STREET ELBOW
4	4376	8	NUT
5	7343	2	COTTER PIN
6	4378	1	NUT
7	4427	1	BOLT
8	4675	1	PISTON NUT
9	8354	2	CLEVIS PIN
10	8784	1	CAP
11	00759734	1	TUBE
12	00759733	1	PISTON
13	00759735	1	PISTON ROD
14	8786	1	HEAD
15	8754	1	FEMALE CLEVIS
16	00759736	4	TIE ROD
	00759737	1	SEAL KIT

# CYLINDER - HYDRAULIC

## MOLDBOARD TILT

**DISCONTINUED**  
FOR REPLACEMENT PARTS  
ONLY  
S/N - 00000 THRU S/N 10927

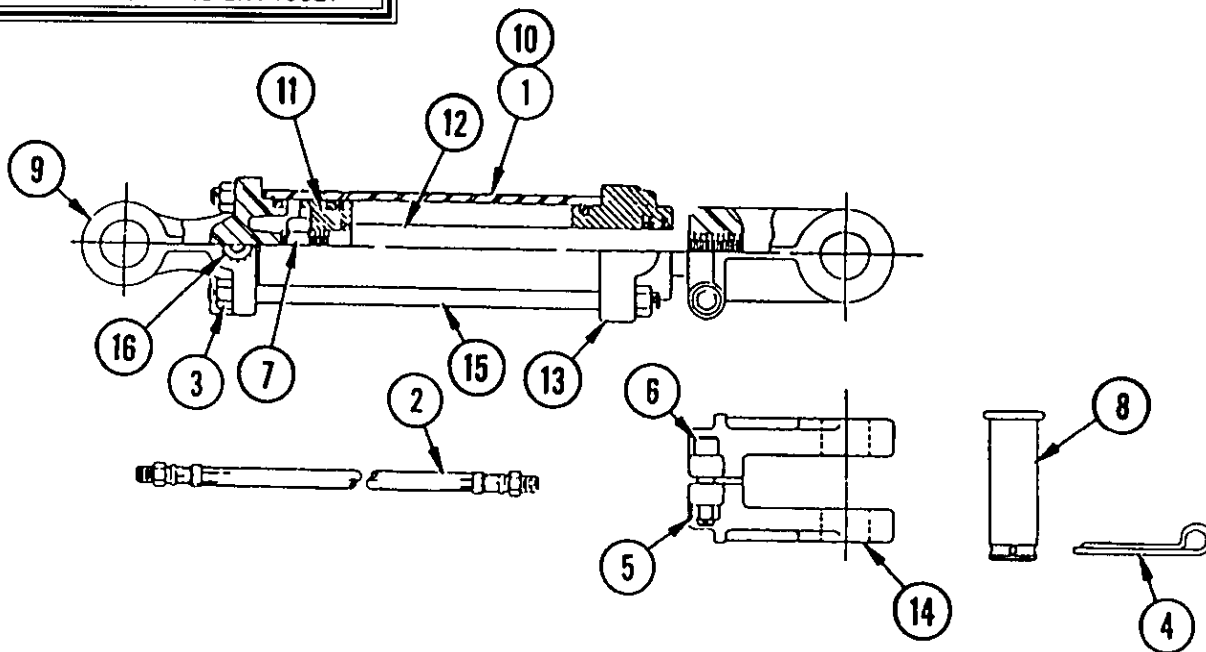

ITEM	PART NO.	QTY.	DESCRIPTION
1	B69135A	1	COMPLETE CYLINDER W/CLEVIS PIN
2	651132	2	HYDRAULIC HOSE
3	00001200	8	HEX NUT
4	00000400	2	COTTER PIN
5	5B6160	1	HEX NUT
6	7E62414	1	BOLT
7	691351	1	PISTON NUT
8	8354	1	CLEVIS PIN
9	69135A2	1	CLEVIS BASE
10	6913010	1	TUBE
11	6913011	1	PISTON
12	6913012	1	ROD
	691353	1	ROD
13	6913013	1	HEAD
	69130A13	1	HEAD
14	691354	1	CLEVIS, PISTON ROD
15	6913014	4	TIE ROD
	69130A14	4	TIE ROD
16	00749508	1	PIPE PLUG
17	691356	1	CLEVIS BASE PIN

# CYLINDER - HYDRAULIC

FOR GAUGE WHEEL

**DISCONTINUED**  
FOR REPLACEMENT  
PARTS ONLY

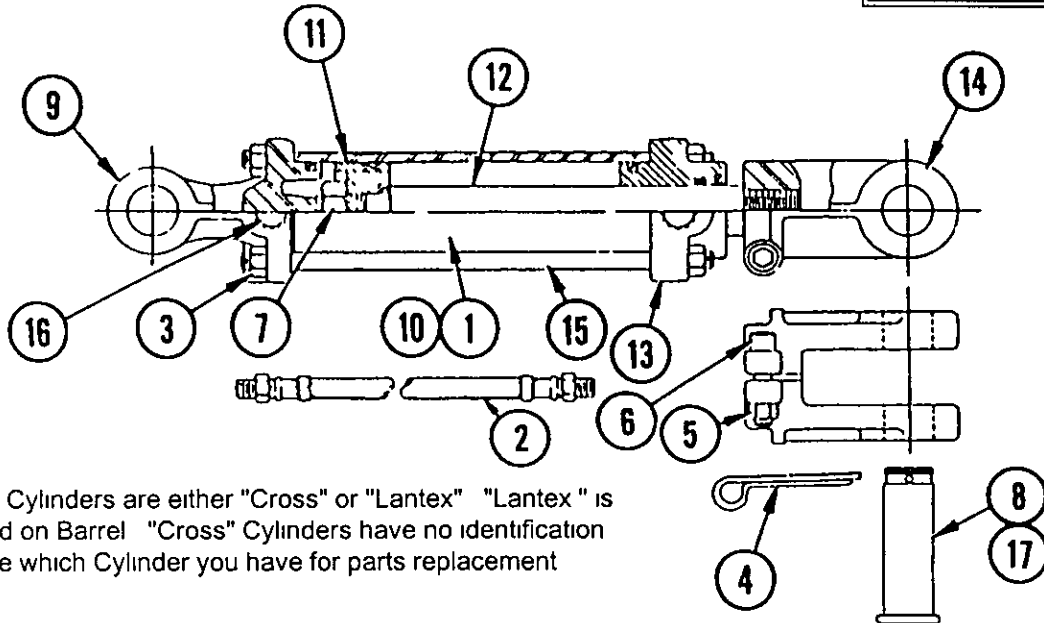

**NOTE** Cylinders are either "Cross" or "Lantex" "Lantex" is stamped on Barrel "Cross" Cylinders have no identification Observe which Cylinder you have for parts replacement

OLD STYLE - 3" BORE

ITEM	PART NO.	QTY.	DESCRIPTION
1	B69135A	1	COMPLETE CYLINDER W/CLEVIS PIN
2	651132	2	HYDRAULIC HOSE
3	00001200	8	HEX NUT
4	00000400	2	COTTER PIN
5	5B6240	1	HEX NUT
6	7E62414	1	BOLT
7	691351	1	PISTON NUT
8	8354	1	CLEVIS PIN
9	0691350014	1	CLEVIS BASE
10	0691350006	1	TUBE
11	0691350004	1	PISTON
12	0691350005	1	ROD
13	0691350010	1	HEAD
14	0651130022	1	CLEVIS, PISTON ROD
15	0691350011	4	TIE ROD

# CYLINDER - HYDRAULIC

## MOLDBOARD TILT

**DISCONTINUED**

FOR REPLACEMENT PARTS  
ONLY  
S/N - 00000 THRU S/N 10927

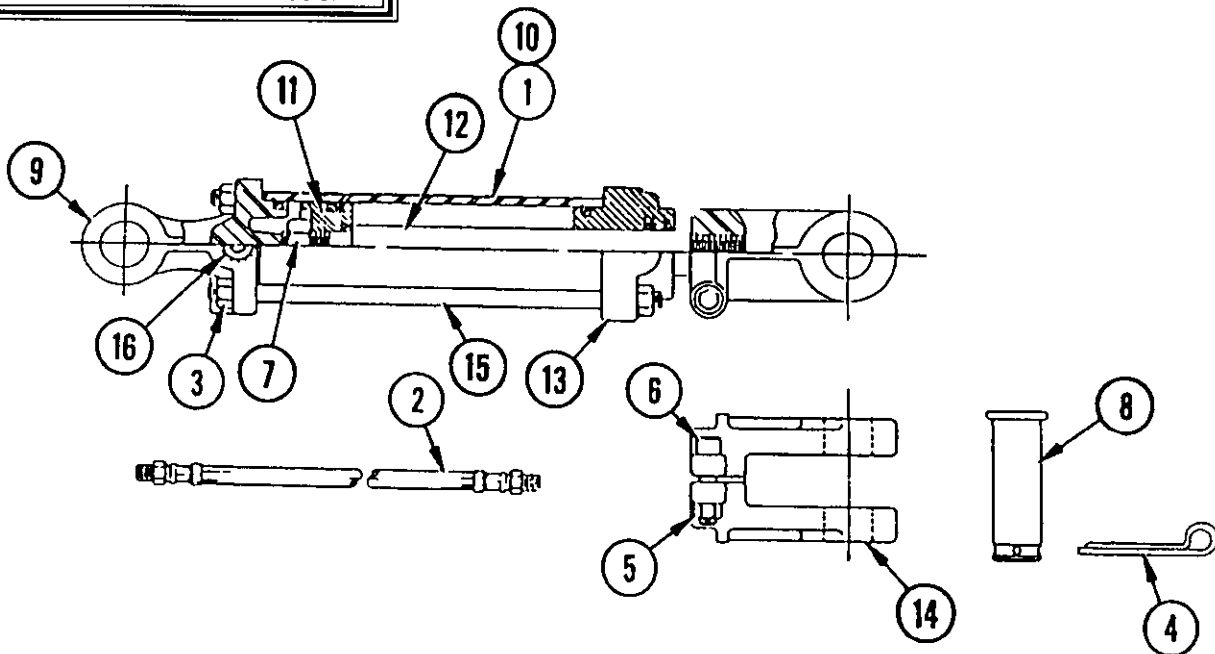

ITEM	PART NO.	QTY.	DESCRIPTION
1	B69131B1	1	HYDRAULIC CYLINDER COMPLETE
2	651132	1	HYDRAULIC HOSE
3	00001200	8	NUT
4	00000400	2	COTTER PIN
5	5B6160	1	HEX NUT
6	6511322	1	BOLT
7	6511320	1	PISTON NUT
8	8354	2	CLEVIS PIN
9	65113A12	1	BASE CLEVIS
10	691314	1	TUBE
11	691315	1	PISTON
12	69131B10	1	PISTON ROD
	691316	1	PISTON ROD
13	65113B8	1	HEAD
	65130A4	1	HEAD
14	691354	1	PISTON ROD CLEVIS
	65130A12	1	PISTON ROD CLEVIS
15	691317	4	TIE ROD
16	00749508	1	PIPE PLUG
	65113A30	ref	SEAL KIT (NOT SHOWN)
	691318	ref	SEAL KIT (NOT SHOWN)

# CYLINDER - HYDRAULIC

## MOLDBOARD TILT

**DISCONTINUED**  
FOR REPLACEMENT PARTS  
ONLY  
S/N - 00000 THRU S/N 10927

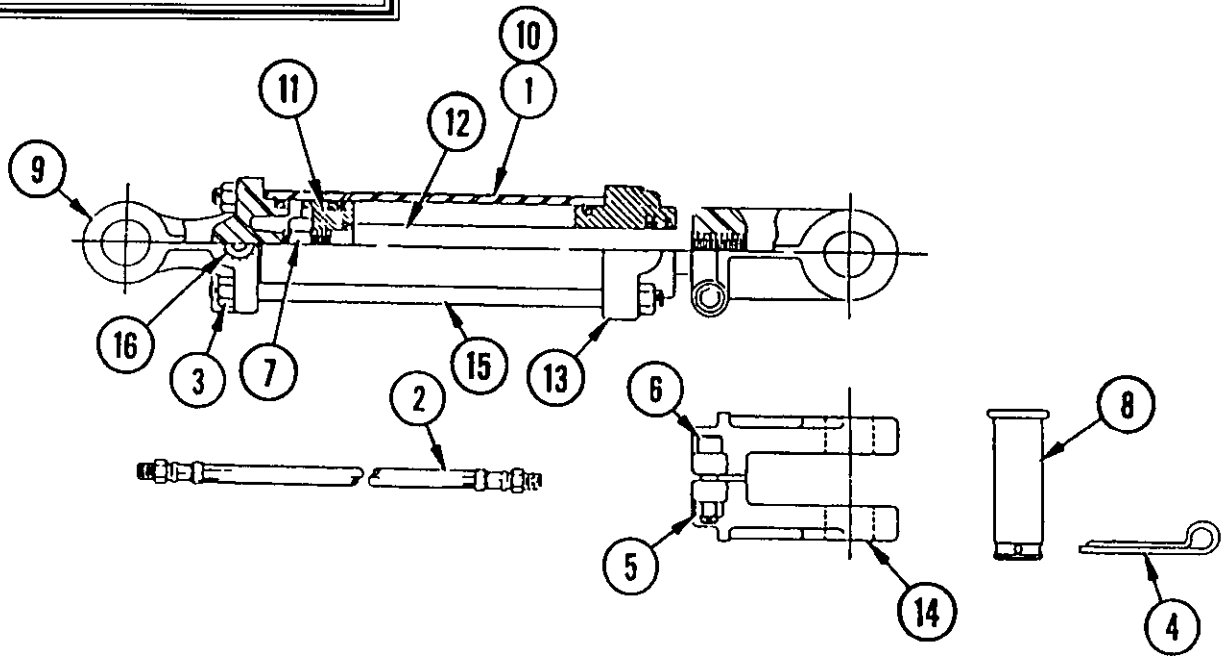

ITEM	PART NO.	QTY.	DESCRIPTION
1	B69131B1	1	HYDRAULIC CYLINDER COMPLETE
2	651132	1	HYDRAULIC HOSE
3	00001200	8	NUT
4	00000400	2	COTTER PIN
5	5B6240	1	HEX NUT
6	7E62414	1	BOLT
7	691351	1	PISTON NUT
8	8354	2	CLEVIS PIN
9	0651130001	1	BASE CLEVIS
10	0691310002	1	TUBE
11	0651130005	1	PISTON
12	0691310001	1	PISTON ROD
13	0651130016	1	HEAD
14	0651130022	1	PISTON ROD CLEVIS
15	691317	4	TIE ROD
	0651130014	ref	SEAL KIT (NOT SHOWN)

# HOSE CONNECTIONS - HYDRAULIC

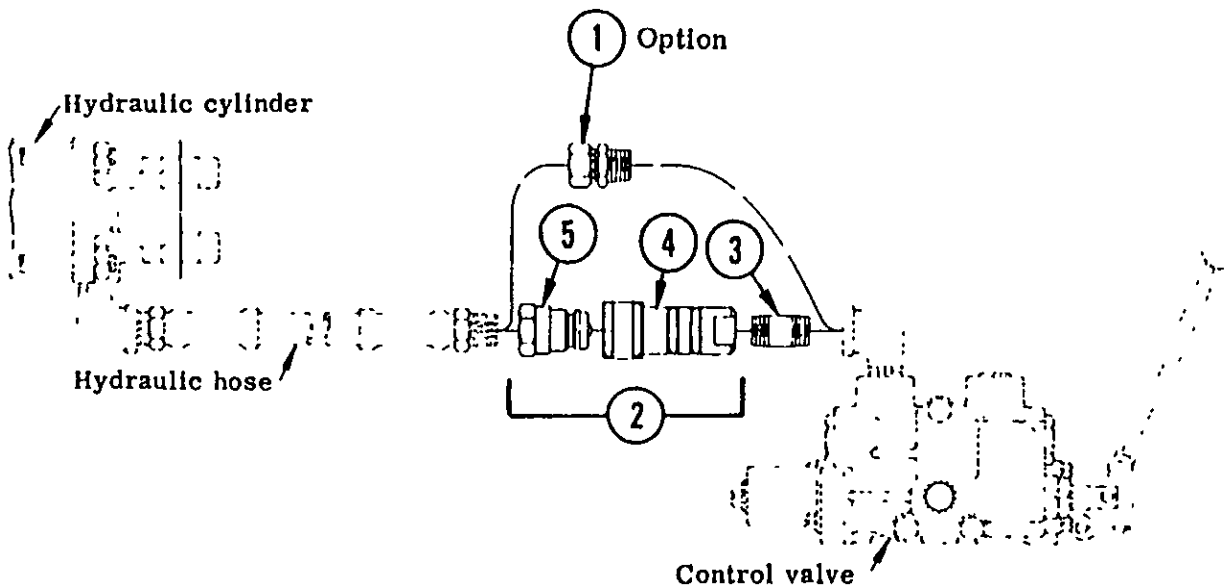

ITEM	PART NO.	QTY.	DESCRIPTION
1	94514	1	SWIVEL FITTING
2	B65131	1	QUICK COUPLER ASSEMBLY
3	02963649	1	NIPPLE
4	651311	1	COUPLER
5	651312	1	COUPLER TIP - MALE



# BRACKET ASSY - CONTROL VALVE

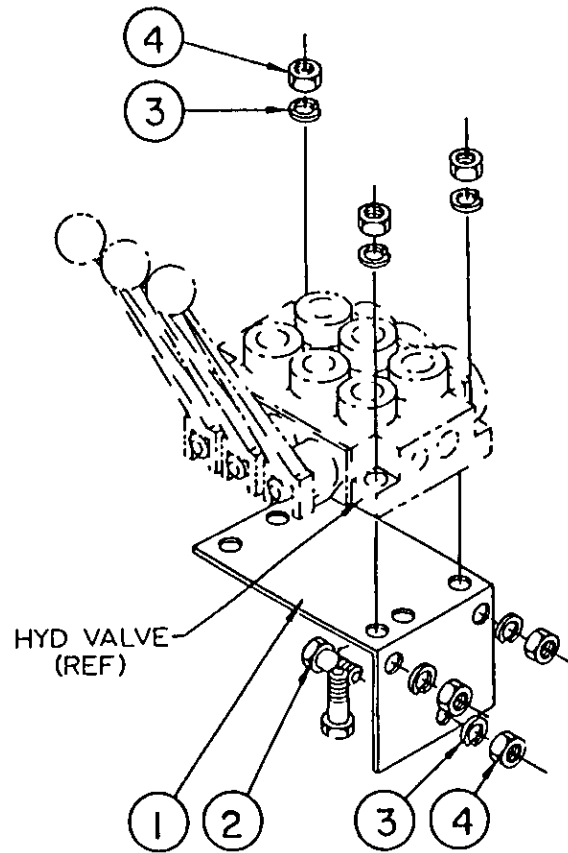

ITEM	PART NO.	QTY.	DESCRIPTION
1	B651401	1	BRACKET W/FASTENERS
2	00016200	6	BOLT
3	13500	6	LOCKWASHER
4	5B5180	6	HEX NUT

# CONTROL VALVE ASSEMBLY

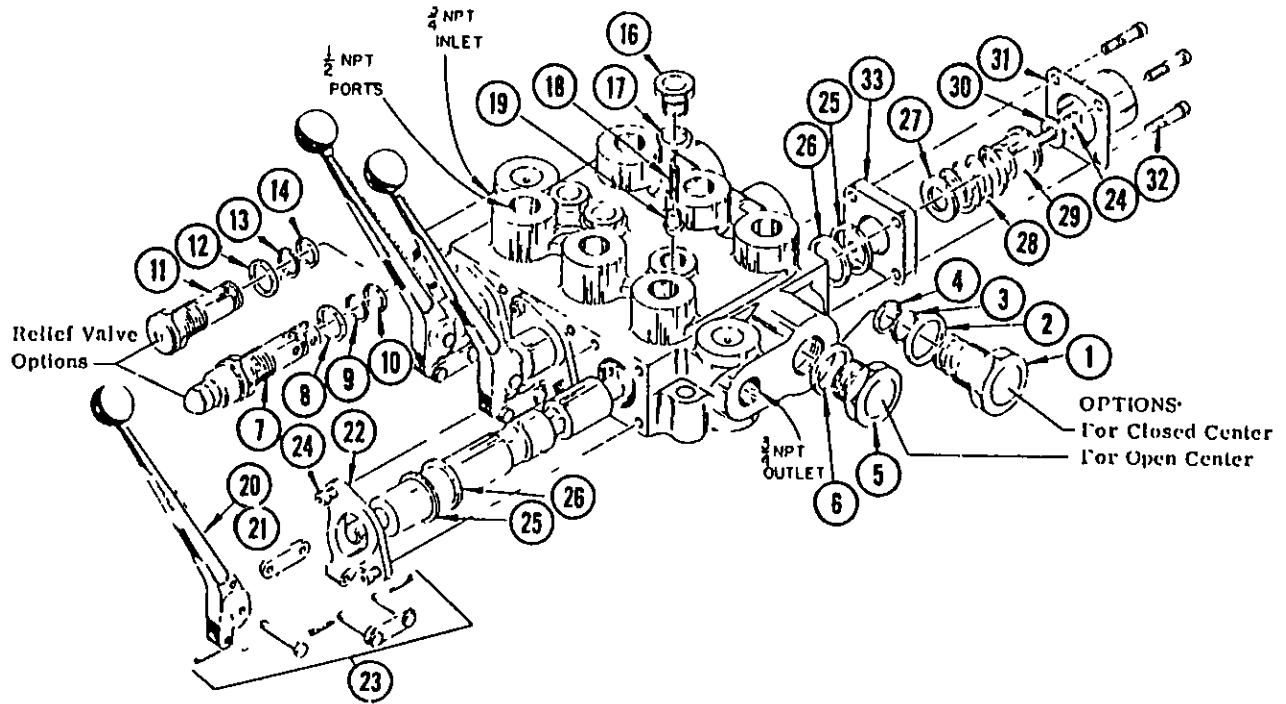

# CONTROL VALVE ASSEMBLY

ITEM	PART NO.	QTY.	DESCRIPTION
	<b>0691700000</b>	<b>1</b>	<b>CONTROL VALVE (OPEN CTR)</b>
	<b>0691710000</b>	<b>1</b>	<b>CONTROL VALVE (CLOSED CTR)</b>
1	6514042	1	CLOSED CTR PLUG ASSY(INCL. 2,3, &4)
2	6514041	1	O-RING SEAL
3	6514044	1	BACK-UP WASHER
4	6514045	1	O-RING SEAL
5	6514039	1	CONV. PLUG ASSY.(FOR OPEN CTR)
6	6514041	1	O-RING SEAL
7	0691700001	1	ADJ. RELIEF ASSEMBLY(INCL. 10-13)
8	6514034	1	O-RING SEAL
9	6514035	1	BACK-UP WASHER
10	6514036	1	O-RING SEAL
11	6514037	1	NO-RELIEF ASSEMBLY(INCL. 12-14)
12	6514034	1	O-RING SEAL
13	6514035	1	BACK-UP WASHER
14	6514036	1	O-RING SEAL
16	6514029	3	PLUG ONLY
17	6514028	3	O-RING SEAL
18	6514027	3	SPRING
19	6514026	3	LOAD CHECK POPPET
20	65140A49	3	HANDLE & BRACKET ASSY(INCL 21-23)
21	65140A47	3	HANDLE
22	65140A46	3	HANDLE BRACKET
23	65140A48	3	PIN KIT
24	7E4204	3	BOLT
25	6514012	6	RETAINER PLATE
26	6514013	6	SPOOL SEAL
27	6514018	3	STOP WASHER
28	6514019	3	SPRING
29	6514020	3	STOP COLLAR
30	6514021	3	WASHER
31	6514022	3	END CAP
32	00021400	12	BOLT
33	6514014	3	SPACER

# VALVE SELECTOR

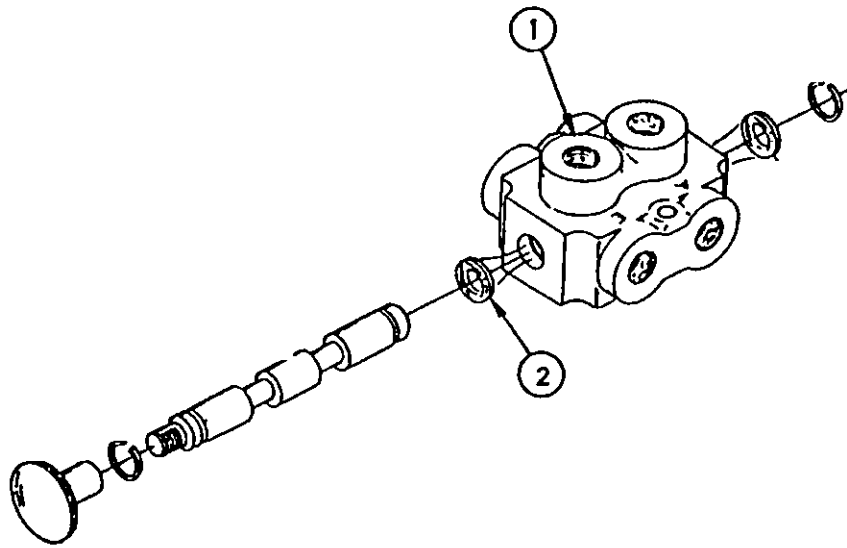

ITEM	PART NO.	QTY.	DESCRIPTION
1	0781300000	1	VALVE ASSEMBLY (COMPLETE)
2	0781300005	2	SEAL

# ADJUST LINK ASSEMBLY

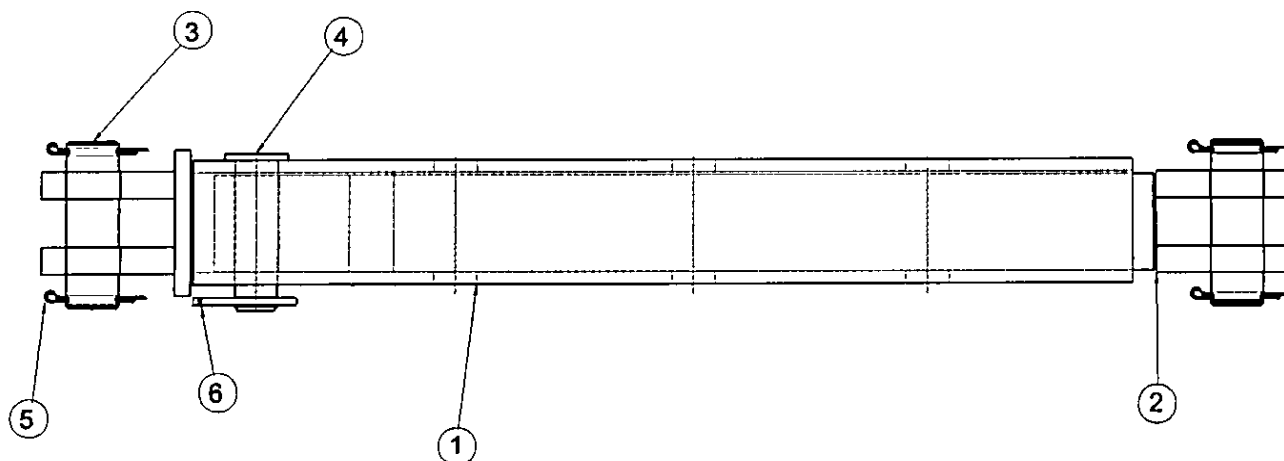

ITEM	PART NO.	QTY.	DESCRIPTION
	<b>B69116B</b>	-	<b>ADJUST LINK ASSEMBLY</b>
1	00776119	1	WDMT. ADJUSTING LINK HOUSING
2	00776121	1	WDMT. ADJUSTING LINK ROD
3	00775916	2	PIN, CYLINDER
4	691154	1	PIN, CLEVIS
5	00606000	4	PIN, COTTER
6	37107B13	1	CLIP, HAIR PIN
7	02969064	2	BUSHING SPRING (NOT SHOWN)

# ADJUST LINK ASSEMBLY

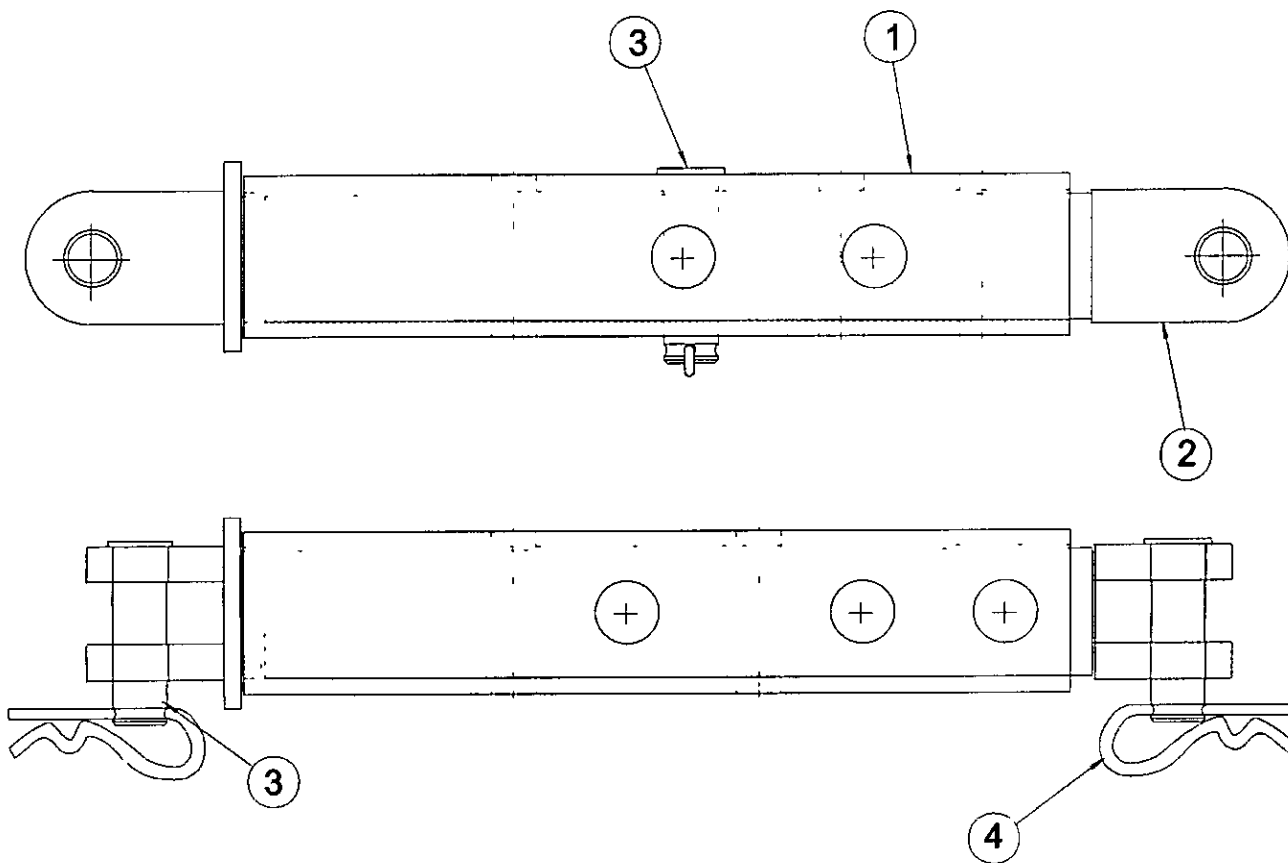

ITEM	PART NO.	QTY.	DESCRIPTION
	<b>B69116B</b>	-	<b>ADJUST LINK ASSEMBLY</b>
1	69116B1	1	ADJUSTING LINK HOUSING
2	69116A2	1	ADJUSTING LINK ROD
3	691154	3	PIN
4	37107B13	3	CLIP PIN

# ADJUSTING LINK - MANUAL

**DISCONTINUED**  
FOR REPLACEMENT  
PARTS ONLY

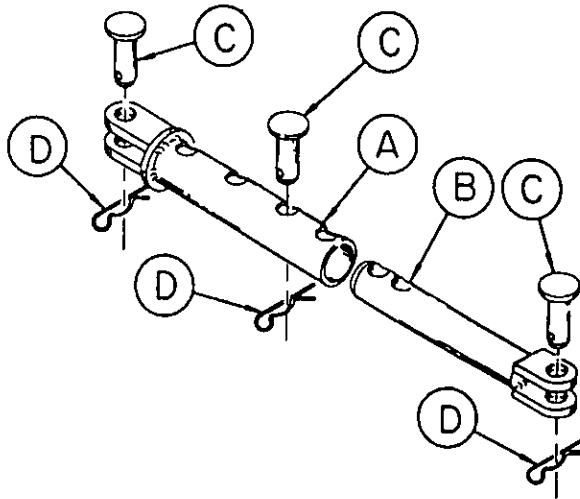

ITEM	PART NO.	QTY.	DESCRIPTION
-	<b>B69115A</b>	-	<b>MAINFRAME SWING &amp; MOLDBOARD PIVOT</b>
A	69115A1	1	ADJUSTING LINK HOUSING WELDMENT
B	69115A2	1	ADJUSTING LINK ROD WELDMENT
C	691154	3	CLEVIS PIN
D	00000400	3	COTTER PIN

# ADJUSTING LINK - MANUAL

**DISCONTINUED**  
FOR REPLACEMENT  
PARTS ONLY

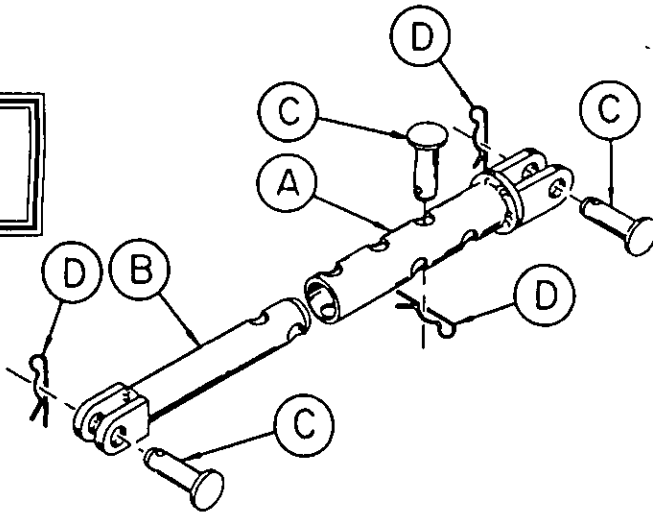

ITEM	PART NO.	QTY.	DESCRIPTION
	<b>B69116B</b>	-	<b>MOLDBOARD TILT</b>
A	69116B1	1	ADJUSTING LINK HOUSING WELDMENT
B	69116A2	1	ADJUSTING LINK ROD WELDMENT
C	691154	3	CLEVIS PIN
D	00000400	3	COTTER PIN



# SAFETY DECAL SHEETS



1

ITEM	PART NO.	QTY.	DESCRIPTION
1	00776261	1	SHEET,1540 BLADE DECAL
2	00776481	1	SHEET,MANUALCANISTER DECAL
3	1458392	1	DECAL,RED REFLECTOR (NOT SHOWN)
4	1458393	1	DECAL,YELLOW REFLECTOR (NOT SHOWN)



# SERVIS-RHINO

## LIMITED WARRANTY

### 1. LIMITED WARRANTIES

- 1.01. Servis-Rhino warrants for one year from the purchase date to the original non-commercial, governmental, or municipal purchaser ("Purchaser") and warrants for six months to the original commercial or industrial purchaser ("Purchaser") that the goods purchased are free from defects in material or workmanship.
- 1.02. Manufacturer will replace for the Purchaser any part or parts found, upon examination at one of its factories, to be defective under normal use and service due to defects in material or workmanship.
- 1.03. This limited warranty does not apply to any part of the goods which has been subjected to improper or abnormal use, negligence, alteration, modification, or accident, damaged due to lack of maintenance or use of wrong fuel, oil, or lubricants, or which has served its normal life. This limited warranty does not apply to any part of any internal combustion engine, or expendable items such as blades, shields, guards, or pneumatic tires except as specifically found in your Operator's Manual.
- 1.04. Except as provided herein, no employee, agent, Dealer, or other person is authorized to give any warranties of any nature on behalf of Manufacturer.

### 2. REMEDIES AND PROCEDURES.

- 2.01. This limited warranty is not effective unless the Purchaser returns the Registration and Warranty Form to Manufacturer within 30 days of purchase.
- 2.02. Purchaser claims must be made in writing to the Authorized Dealer ("Dealer") from whom Purchaser purchased the goods or an approved Authorized Dealer ("Dealer") within 30 days after Purchaser learns of the facts on which the claim is based.
- 2.03. Purchaser is responsible for returning the goods in question to the Dealer.
- 2.04. If after examining the goods and/or parts in question, Manufacturer finds them to be defective under normal use and service due to defects in material or workmanship, Manufacturer will:
  - (a) Repair or replace the defective goods or part(s) or
  - (b) Reimburse Purchaser for the cost of the part(s) and reasonable labor charges (as determined by Manufacturer) if Purchaser paid for the repair and/or replacement prior to the final determination of applicability of the warranty by Manufacturer.The choice of remedy shall belong to Manufacturer.
- 2.05. Purchaser is responsible for any labor charges exceeding a reasonable amount as determined by Manufacturer and for returning the goods to the Dealer, whether or not the claim is approved. Purchaser is responsible for the transportation cost for the goods or part(s) from the Dealer to the designated factory.

### 3. LIMITATION OF LIABILITY.

- 3.01. MANUFACTURER DISCLAIMS ANY EXPRESS (EXCEPT AS SET FORTH HEREIN) AND IMPLIED WARRANTIES WITH RESPECT TO THE GOODS INCLUDING, BUT NOT LIMITED TO, MERCHANTABILITY AND FITNESS FOR A PARTICULAR PURPOSE.
- 3.02. MANUFACTURER MAKES NO WARRANTY AS TO THE DESIGN, CAPABILITY, CAPACITY, OR SUITABILITY FOR USE OF THE GOODS.
- 3.03. EXCEPT AS PROVIDED HEREIN, MANUFACTURER SHALL HAVE NO LIABILITY OR RESPONSIBILITY TO PURCHASER OR ANY OTHER PERSON OR ENTITY WITH RESPECT TO ANY LIABILITY, LOSS, OR DAMAGE CAUSED OR ALLEGED TO BE CAUSED DIRECTLY OR INDIRECTLY BY THE GOODS INCLUDING, BUT NOT LIMITED TO, ANY INDIRECT, SPECIAL, CONSEQUENTIAL, OR INCIDENTAL DAMAGES RESULTING FROM THE USE OR OPERATION OF THE GOODS OR ANY BREACH OF THIS WARRANTY. NOT WITHSTANDING THE ABOVE LIMITATIONS AND WARRANTIES, MANUFACTURER'S LIABILITY HEREUNDER FOR DAMAGES INCURRED BY PURCHASER OR OTHERS SHALL NOT EXCEED THE PRICE OF THE GOODS.
- 3.04. NO ACTION ARISING OUT OF ANY CLAIMED BREACH OF THIS WARRANTY OR TRANSACTIONS UNDER THIS WARRANTY MAY BE BROUGHT MORE THAN TWO (2) YEARS AFTER THE CAUSE OF ACTION HAS OCCURRED.

### 4. MISCELLANEOUS.

- 4.01. Proper Venue for any lawsuits arising from or related to this limited warranty shall be only in Guadalupe County, Texas.
- 4.02. Manufacturer may waive compliance with any of the terms of this limited warranty, but no waiver of any terms shall be deemed to be a waiver of any other term.
- 4.03. If any provision of this limited warranty shall violate any applicable law and is held to be unenforceable, then the invalidity of such provision shall not invalidate any other provisions herein.
- 4.04. Applicable law may provide rights and benefits to purchaser in addition to those provided herein.

### KEEP FOR YOUR RECORDS

ATTENTION: Purchaser should fill in the blanks below for his reference when buying repair parts and/or for proper machine identification when applying for warranty.

Servis-Rhino Implement Model \_\_\_\_\_ Serial Number \_\_\_\_\_

Date Purchased \_\_\_\_\_ Dealer \_\_\_\_\_

ATTENTION:  
READ YOUR OPERATOR'S MANUAL

**RHINO**<sup>®</sup>  
1020 S. Sangamon Ave.  
Gibson City, IL 60936  
800-446-5158  
Email: parts@servis-rhino.com





## TO THE OWNER/OPERATOR/DEALER

To keep your implement running efficiently and safely, read your manual thoroughly and follow these directions and the Safety Messages in this Manual. The Table of Contents clearly identifies each section where you can easily find the information you need.

The OCCUPATIONAL SAFETY AND HEALTH ACT (1928.51 Subpart C) makes these minimum safety requirements of tractor operators:

### REQUIRED OF THE OWNER:

1. Provide a Roll-Over-Protective Structure that meets the requirements of this Standard; and
2. Provide Seatbelts that meet the requirements of this paragraph of this Standard and SAE J4C; and
3. Ensure that each employee uses such Seatbelt while the tractor is moving; and
4. Ensure that each employee tightens the Seatbelt sufficiently to confine the employee to the protected area provided by the ROPS.

### REQUIRED OF THE OPERATOR

1. Securely fasten seatbelt if the tractor has a ROPS.
2. Where possible, avoid operating the tractor near ditches, embankments, and holes.
3. Reduce speed when turning, crossing slopes, and on rough, slick, or muddy surfaces.
4. Stay off slopes too steep for safe operation.
5. Watch where you are going - especially at row ends, on roads, and around trees.
6. Do not permit others to ride.
7. Operate the tractor smoothly - no jerky turns, starts, or stops.
8. Hitch only to the drawbar and hitch points recommended by the tractor manufacturer.
9. When the tractor is stopped, set brakes securely and use park lock, if available.



**Keep children away from danger all day, every day...**



**Equip tractors with rollover protection (ROPS) and keep all machinery guards in place...**



**Please work, drive, play and live each day with care and concern for your safety and that of your family and fellow citizens.**



## Free Manuals Download Website

<http://myh66.com>

<http://usermanuals.us>

<http://www.somanuals.com>

<http://www.4manuals.cc>

<http://www.manual-lib.com>

<http://www.404manual.com>

<http://www.luxmanual.com>

<http://aubethermostatmanual.com>

Golf course search by state

<http://golfingnear.com>

Email search by domain

<http://emailbydomain.com>

Auto manuals search

<http://auto.somanuals.com>

TV manuals search

<http://tv.somanuals.com>