

INSTRUCTION MANUAL FOR YOUR RICCAR SEWING MACHINE

R700 / R1100

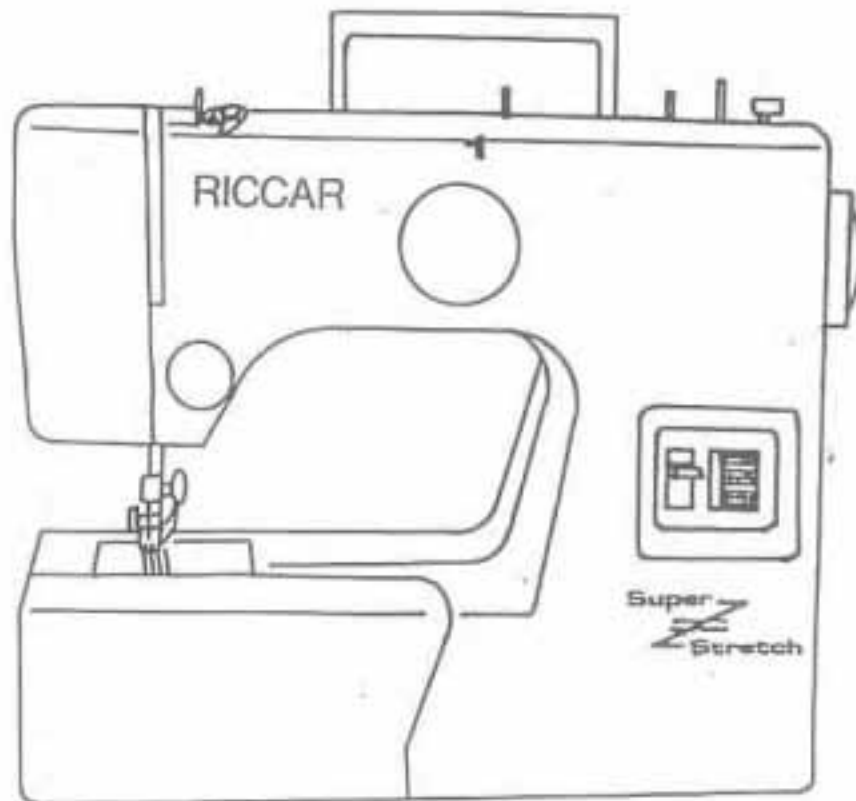

IBR1100

Name of Parts	1 & 2
Accessories.3
Before sewing (Power supply and Sewing lamp).4
Take out extension table, free arm sewing5
Winding the bobbin6
Removing bobbin case and bobbin7
Inserting bobbin into bobbin case.7
Inserting bobbin case into shuttle race.8
Threading upper thread & Twin needle threading.	9
Drawing up bobbin thread.	10
Changing sewing directions	10
Leveling machine & Adjusting thread tension.	11&12
Regulating the presser foot pressure	13
Drop feed	13
Changing needle	14
Fabric, Thread, Needle table	15
Sewing (pattern selector) and operation table	16
To start sewing	17
To finish seam	18
Straight stitch.	19
Zigzag sewing	19
Overcasting	20
Stretch stitch	20
Blind stitch	21 & 22
Button sewing.23
Binding23
Zipper sewing.24
Button hole sewing25
Hemming.26
Twin Needle.27
Embroidery27
Quilter28
Seam guide.28
Maintenance (Cleaning and oiling)29
Checking Performance Problems WHAT TO DO30

NAME OF PARTS (FRONT VIEW)

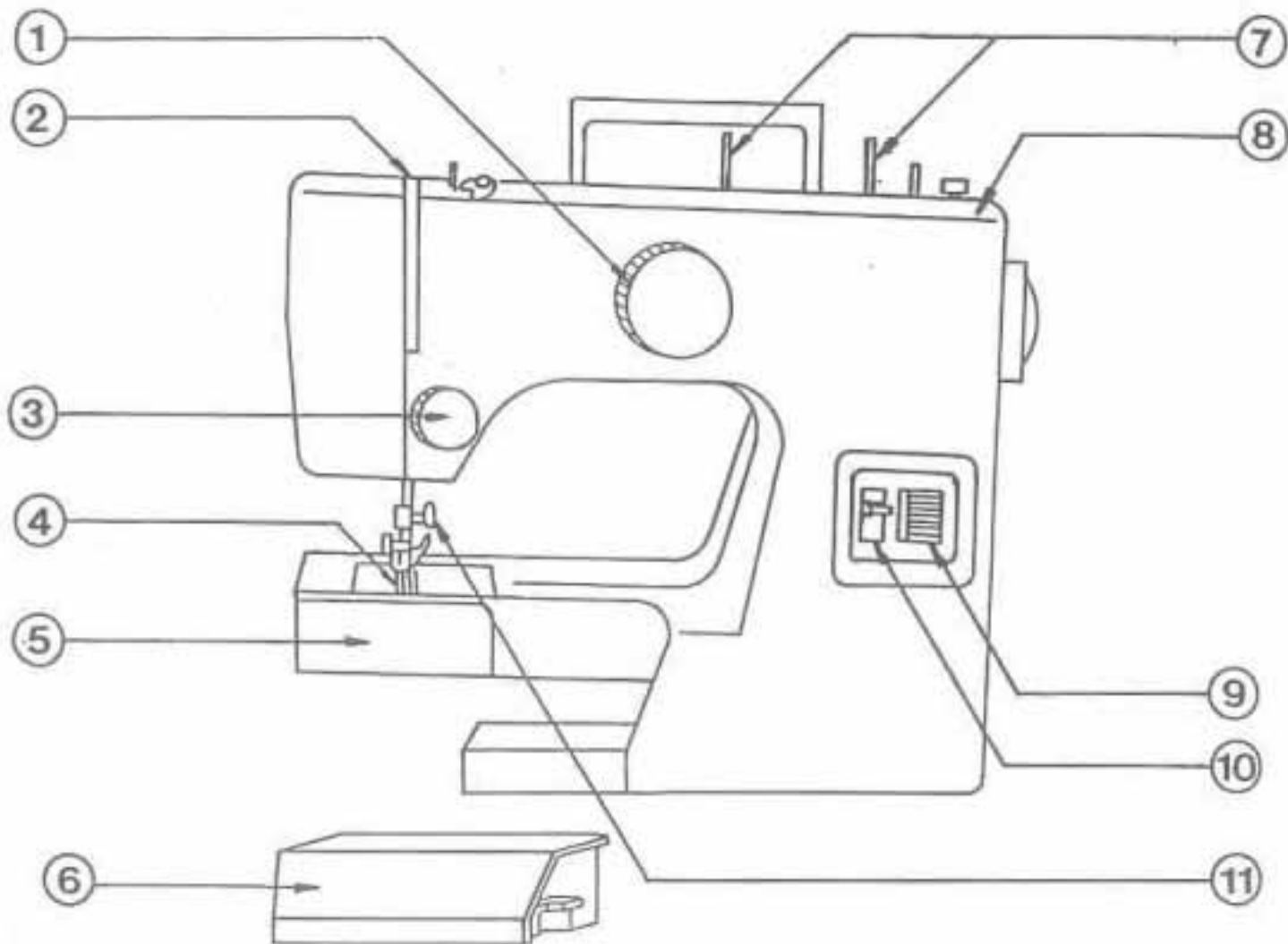

- 1 Pattern selector dial
- 2 Take up lever
- 3 Thread tension dial
- 4 Presser foot
- 5 Shuttle cover
- 6 Extension table

- 7 Spool pins
- 8 Top cover
- 9 Stitch length dial
- 10 Reverse button
- 11 Thread guide for upper threading

(REAR VIEW)

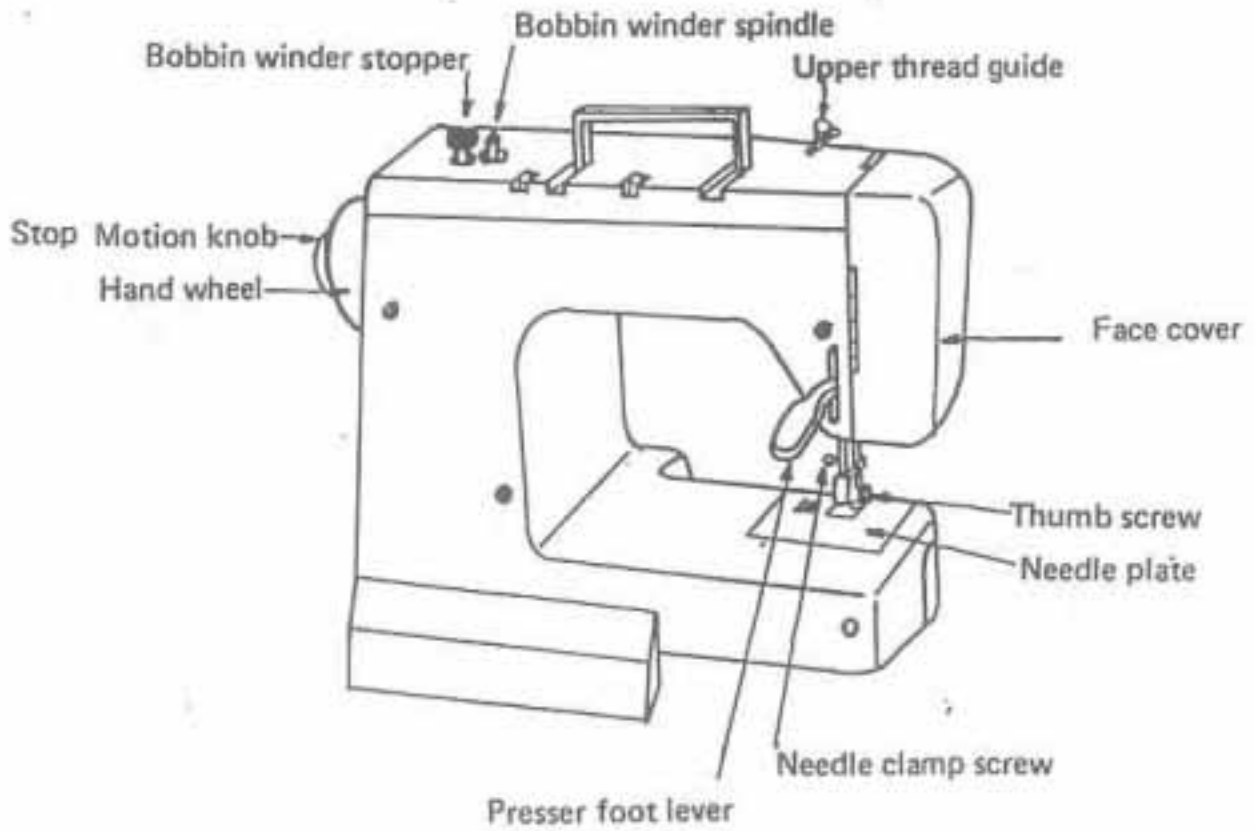

ACCESSORIES



Bobbin



Felt



Zigzag foot
(On machine)

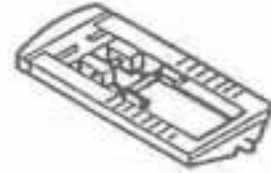

Button hole foot



Seam guide

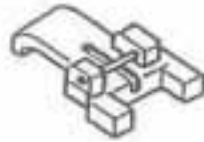

Button foot



Hem guide



Zipper foot



Machine Oil

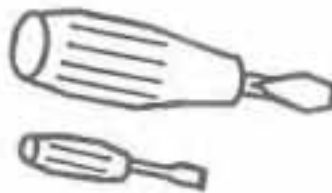

Screw driver
(Large & small)



Button hole cutter



Darning Plate



Quilter



Needle

11 # 14

BEFORE SEWING

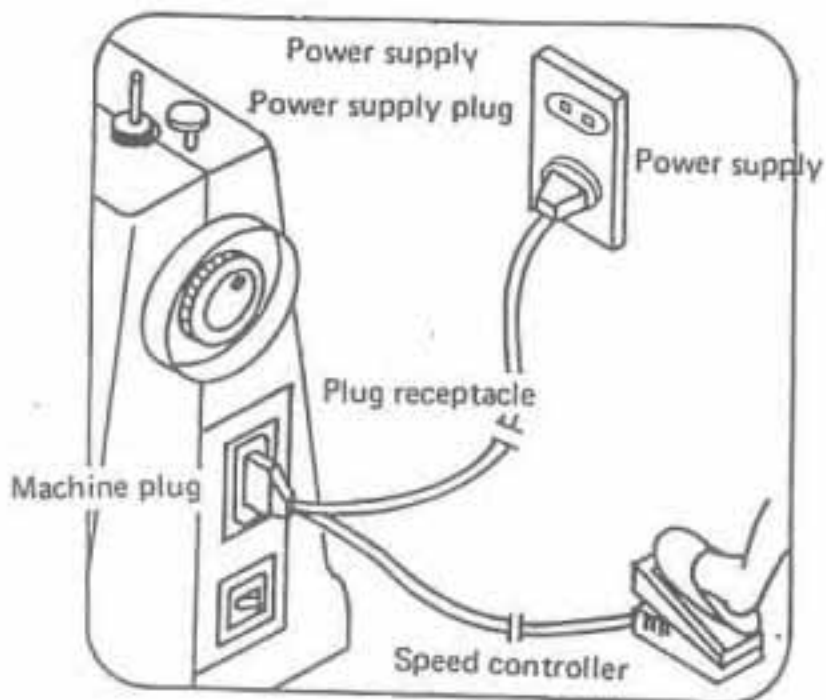

1. Fit the machine plug into the machine.
2. Plug the machine to the power supply.
3. Sewing speed can be varied by the speed controller.

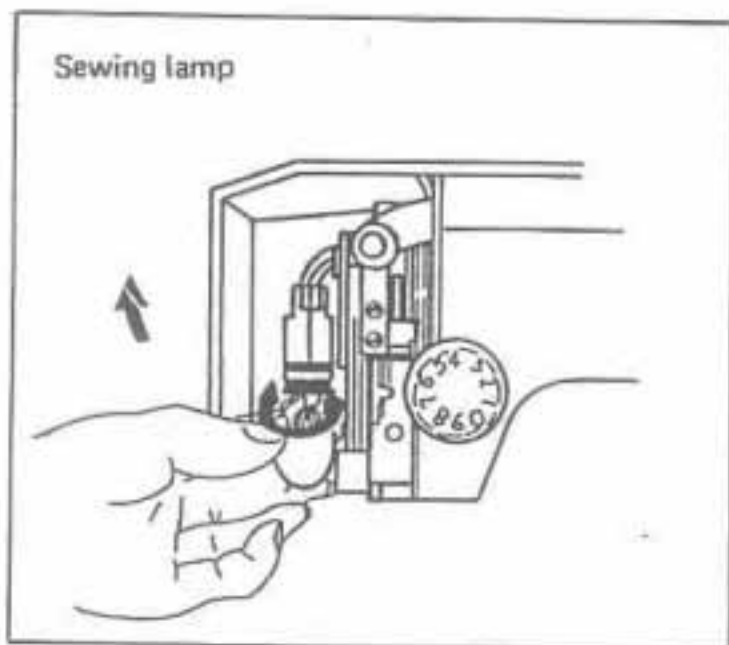

1. Remove or install bulb from inside of face cover.
2. Open face cover in direction of arrow.
3. Remove bulb by unscrewing it counter clockwise.
4. Install a new bulb by screwing it in clockwise.
5. Use a screw type bulb with 120V/15W. (Max)

• REMOVING EXTENSION TABLE

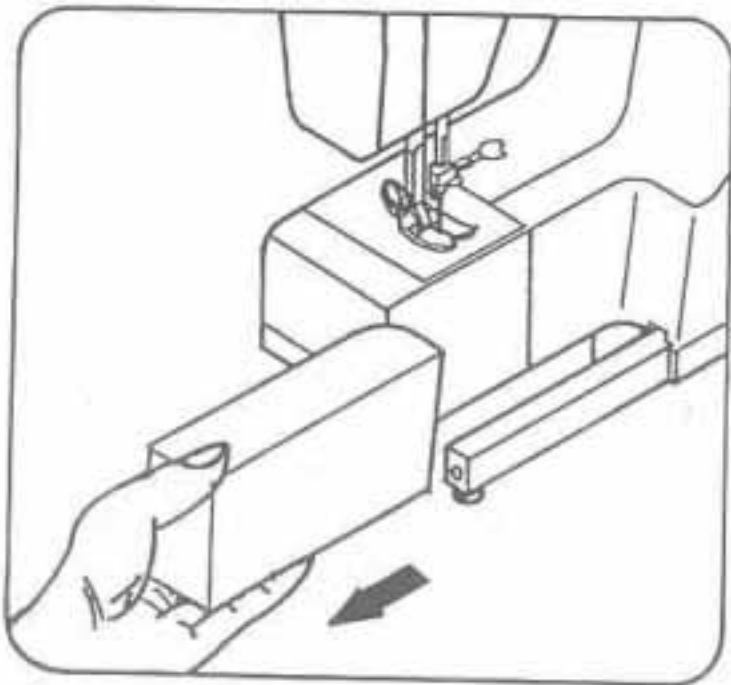

1. Hold the left end of table and pull out in direction of arrow.

FREE-ARM SEWING

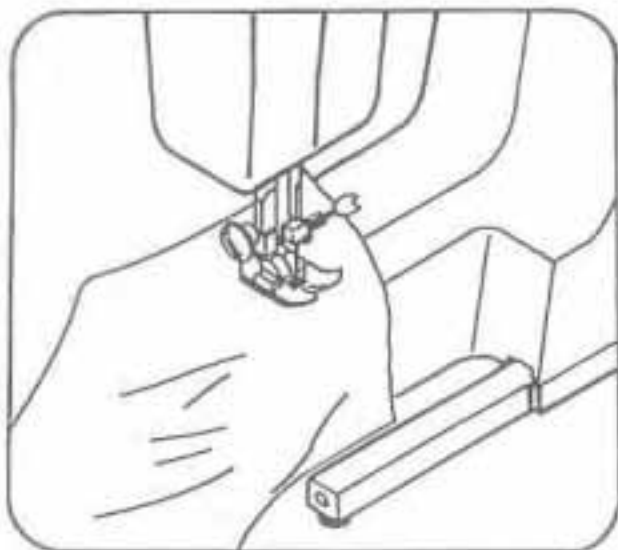

1. Especially useful when sewing sleeves, pants leg, tubular fabrics etc more easily.
2. To sew tubular just slip the sleeve or pants leg on the free arm as shown above.
3. This sewing machine can be used as a flat bed machine, but easily converts to free arm machine by removing the extension table.

WINDING THE BOBBIN

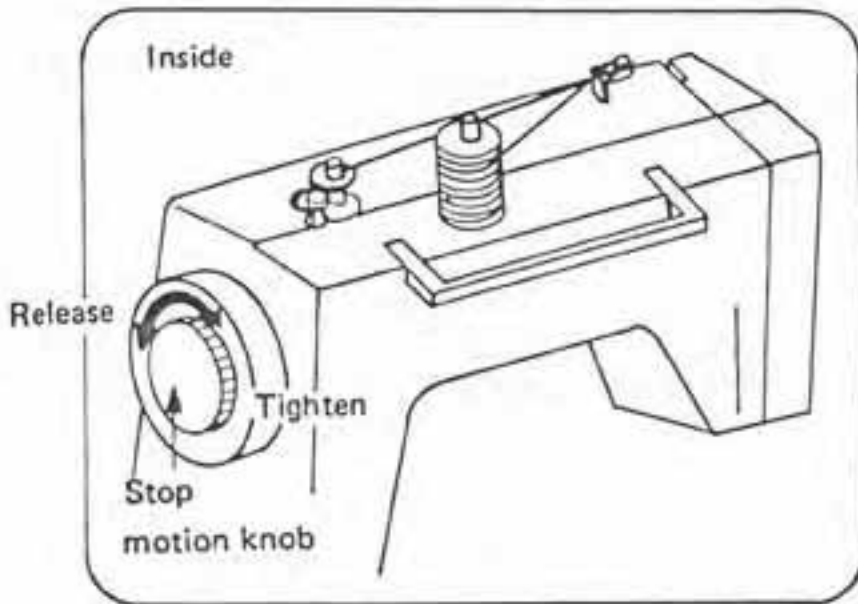

1. Release stop motion knob.
2. Thread as shown.
3. When bobbin is filled, tighten stop motion knob.



Push bobbin winder spindle in direction of arrow.

When bobbin winding is completed return spindle to original position.

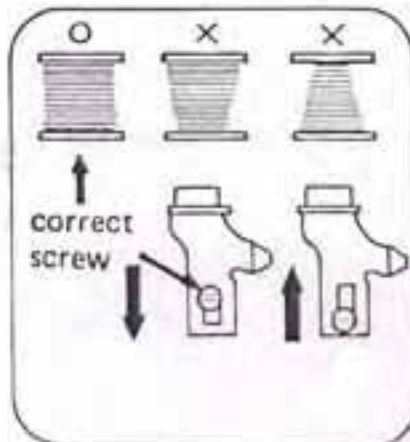

When bobbin winding is incorrect, release the screw of upper thread guide and adjust up or down until bobbin winding is balanced.

REMOVING BOBBIN CASE AND BOBBIN

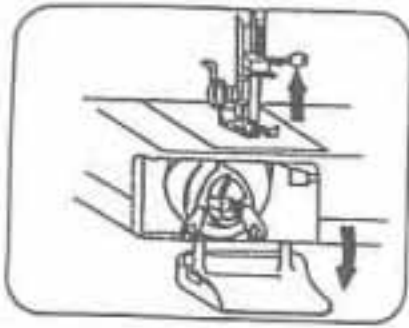

1. Raise needle to its highest position and open the shuttle race cover.



Hinged latch

2. Open hinged latch of bobbin case and pull bobbin case out of machine.

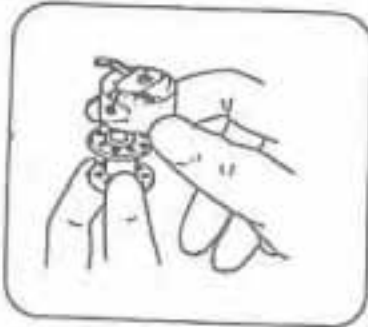

3. Release the latch and bobbin will fall out easily.

INSERTING BOBBIN INTO BOBBIN CASE

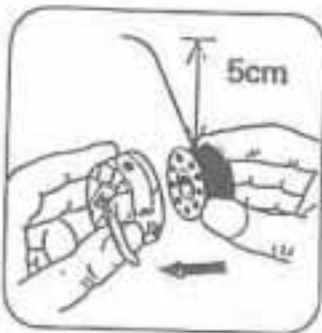

1. Pull off 5cm of thread from bobbin and insert it into bobbin case as shown.

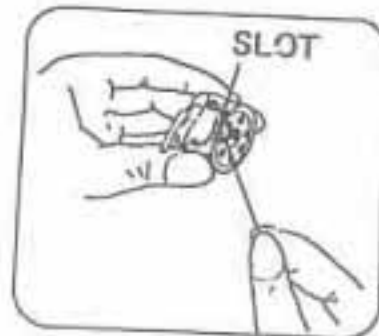

SLOT

2. Guide the end of thread into slot.

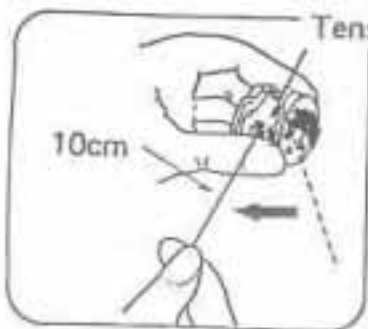

Tension spring

10cm

3. Pull into slot and under tension spring and draw out about 10 cm of thread.

INSERTING BOBBIN CASE INTO SHUTTLE RACE

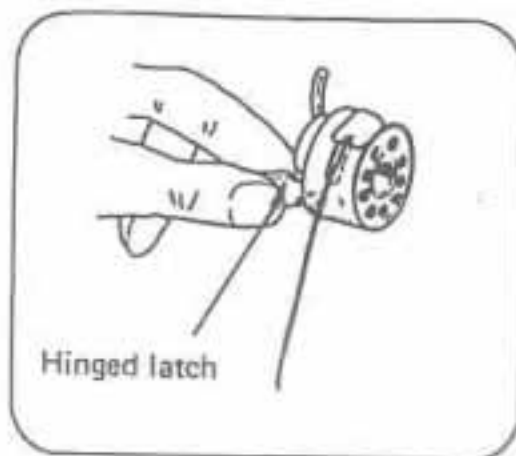

1. Raise needle to its highest position, pulling thread to the front, open the latch of bobbin case and hold it.

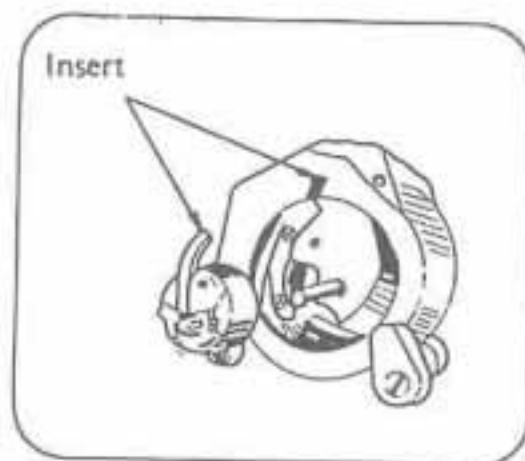

2. Holding latch open, place bobbin case onto centre pin in shuttle and release latch

THREADING UPPER THREAD

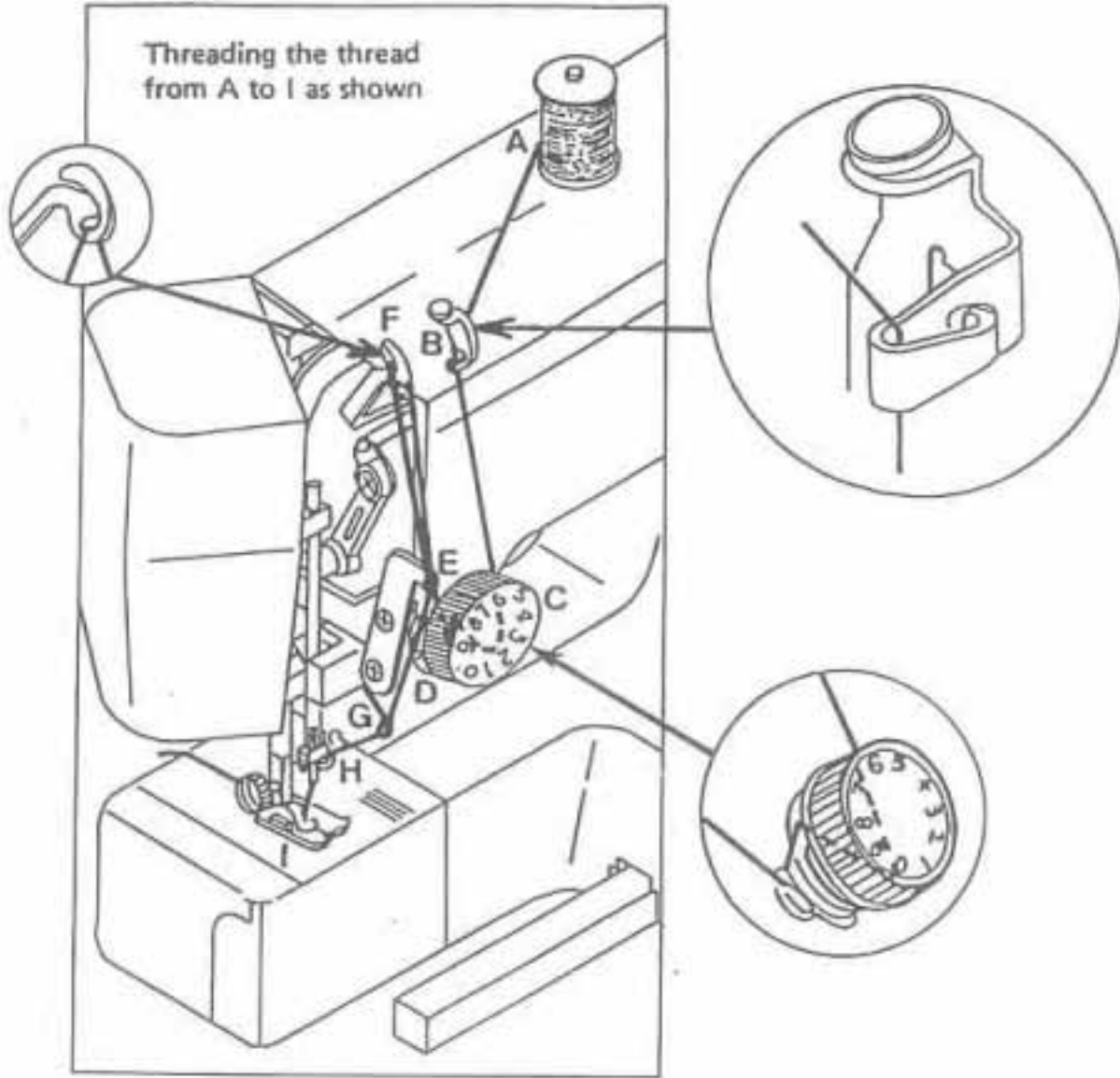

Twin needle threading

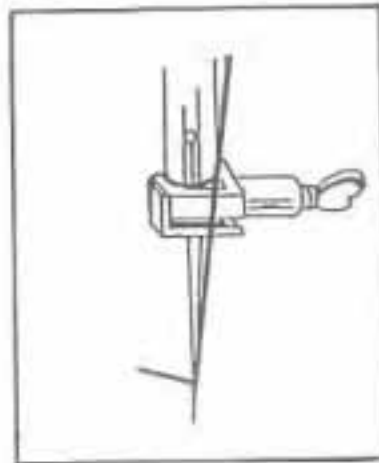
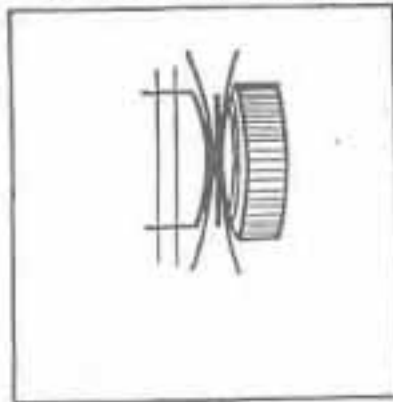

DRAWING UP BOBBIN THREAD

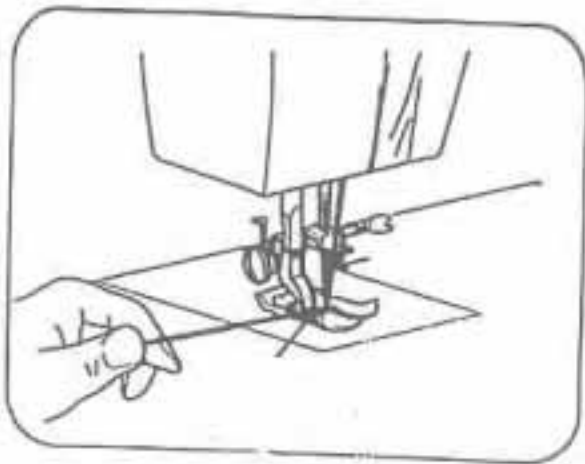

1. Hold upper thread with left hand, turn the hand wheel slowly towards you until the needle goes down and comes up. Then stop the hand wheel when the takeup lever is at its highest position. Lightly draw up the upper thread will be brought up in a loop.

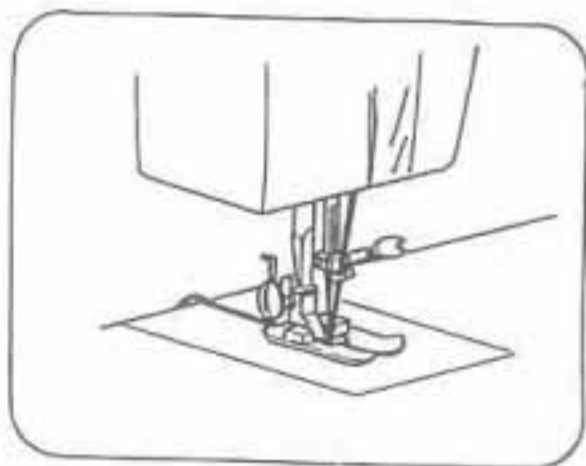

2. Pull out both threads and place them together under presser foot to the rear of machine.

CHANGING SEWING DIRECTIONS

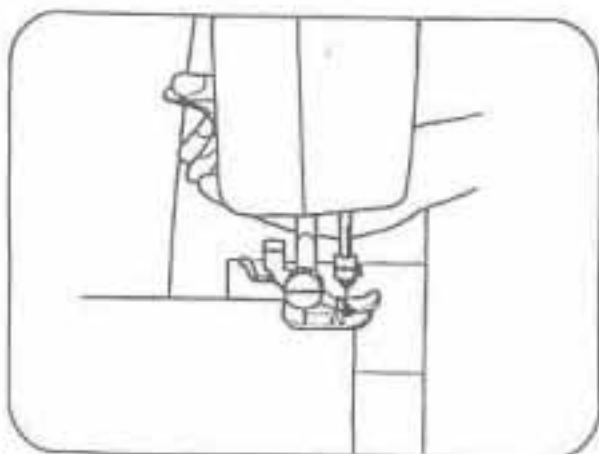

1. Lower needle down into fabric and raise presser foot, pivot the fabric around the needle to change direction as desired.

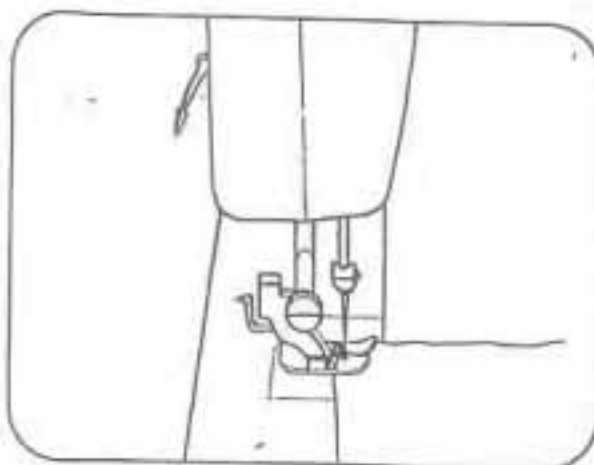

2. Put down presser foot and start to sew.

LEVELING MACHINE

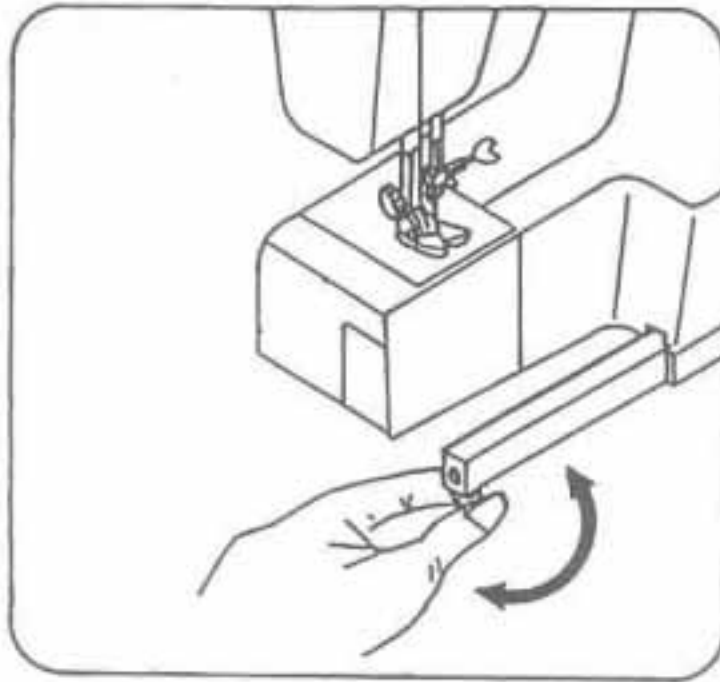

ADJUSTING THREAD TENSION

Correct



Upper thread tension may be adjusted by turning the thread tension dial.

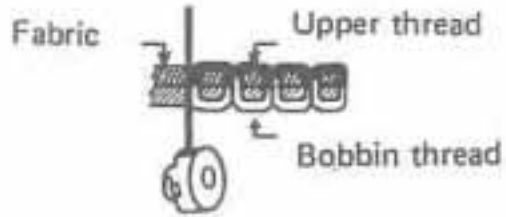

Incorrect

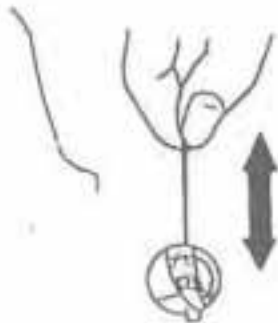

Lower thread tension can be adjusted by turning screw on bobbin case slightly to the right (clock-wise) to increase tension. (Anti-clockwise) to the left to decrease tension.

REGULATING THE PRESSER FOOT PRESSURE

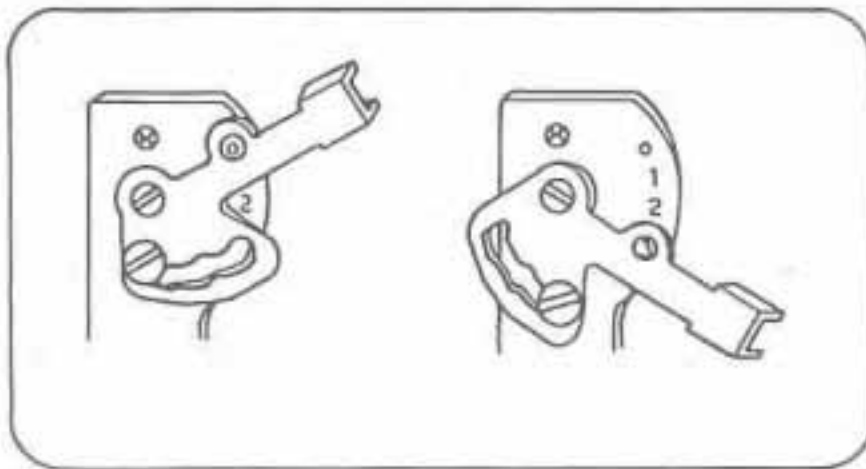

1. Push down lever for desired pressure, for light fabrics set lever at 1, set at 2 for medium fabrics and 3 for heavy fabrics.
2. Insufficient pressure may cause poor feeding, skipped stitches, or difficulty in guiding the fabric.
3. When darning or sewing freehand embroidery release the pressure by setting the lever on 0.

DROP FEED

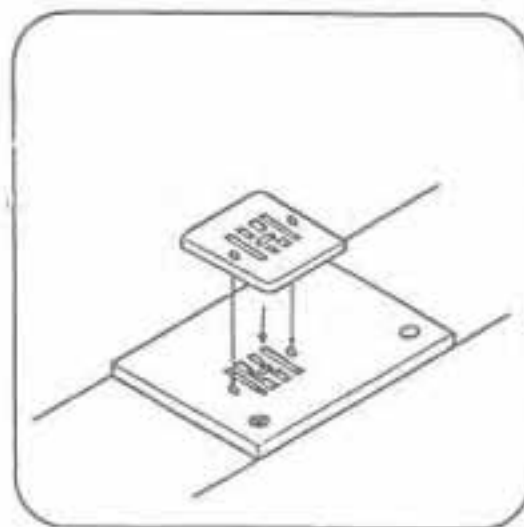
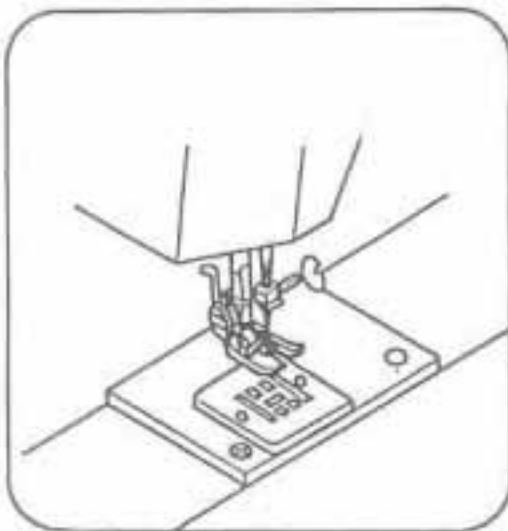

There are a few times when you want to control the feeding of fabric by yourself.

Raise needle bar to its highest position and raise presser foot, place darning plate over needle plate aligning two pins of darning plate with holes of needle plate. You may then determine the movement of the fabric by yourself. See page 20 for button sewing application



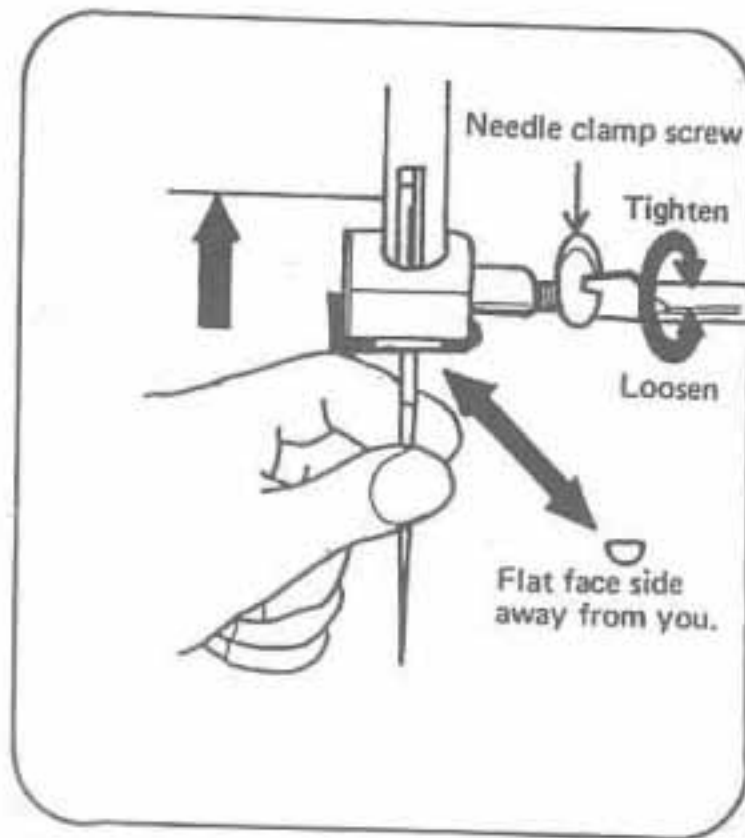











CHANGING NEEDLE



1. Raise needle to its highest position.
2. Loosen needle clamp screw and remove old needle.
3. With the flat side of the needle facing away from you, insert needle as far up as it will go.
4. Tighten the needle clamp screw securely.

FABRIC · THREAD · NEEDLE TABLE

Please note that the following list is a guide when sewing different fabrics.

	Fabric	Thread	Needle	Pressure of presser foot	Length of stitches		Indication of tension
					ST.	ZZ.	
					Stitch length dial		
							
Light 	Nylon	80 Cotton	9		1-3	1-4	
	Tricot	60 S. Fiber					
	Silk	50 silk					
	Wool silk	50 S. Fiber Silk	11				
Medium 	Ging ham	60-80 Cotton	11-14		0.5 - 3	0.5 - 4	
	Thin Jersey	60 S. Fiber	11				
	Gabardine	50 Silk					
Heavy 	Denim	50 cotton	14-16		0.5 - 3	0.5 - 4	
	Jersey	50 S. Fiber	11-14				
	Tweed	50 Silk	11-14				

SEWING (PATTERN SELECTOR) AND OPERATION TABLE

Operation Sewing way	Pattern	Stitch length	Presser foot	Drop feed
1 Straight stitch		0 — 4		
2 Zig-zag		0 — 4		
3 Full auto zig-zag		1 — 3		
4 Super Zig-zag		1 — 2		
		4 — 4		
5 Button hole		0 — 0.25 — 1		
6 Twin needle	except button hole 	0 — 2		
7 Embroidery		0 — 0	No need	

TO START SEWING

Important Hints.

1. Raise the take-up lever to its highest position when starting and stopping sewing.
2. Hold both threads about 10 cms to the rear of machine for the first two to three stitches.
3. Sufficient fabric should be placed under needle before lowering presser foot.
4. Depress foot/Speed control and start to sew.
5. Test the machine stitches on a scrap of fabric you plan to use, adjusting the machine for the length of stitch and tension suitable to your fabric.

:Attention.

1. When turning the hand wheel manually, always turn it toward you.
2. Guide the cloth gently with your hand.
3. To prevent breaking needle always stop with the needle out of the fabric.

TO FINISH SEAM

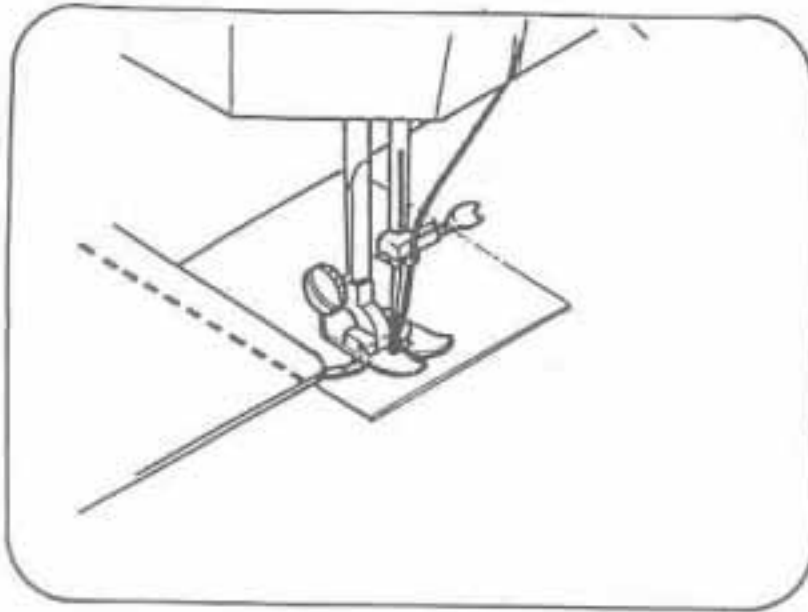

1. Sew to the edge of seam.
2. Push the reverse button and sew in reverse for about 3—4 cms.
3. Raise needle to its highest position.
4. Lift presser foot and pull out the fabric to rear of machine.

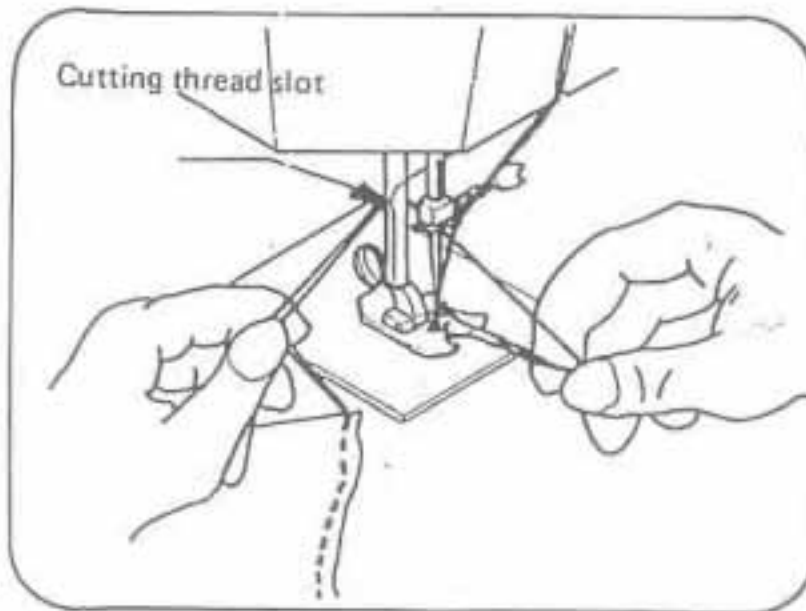

5. Cut threads as shown on the thread cutter.

STRAIGHT STITCH

1. This type of stitching is the one used most frequently.
2. The zig-zag presser foot can be used for both straight and zig-zag sewing.
3. For sewing light fabric, use smaller stitch size and left needle position. (Refer to page 15 for dial setting).

ZIGZAG SEWING

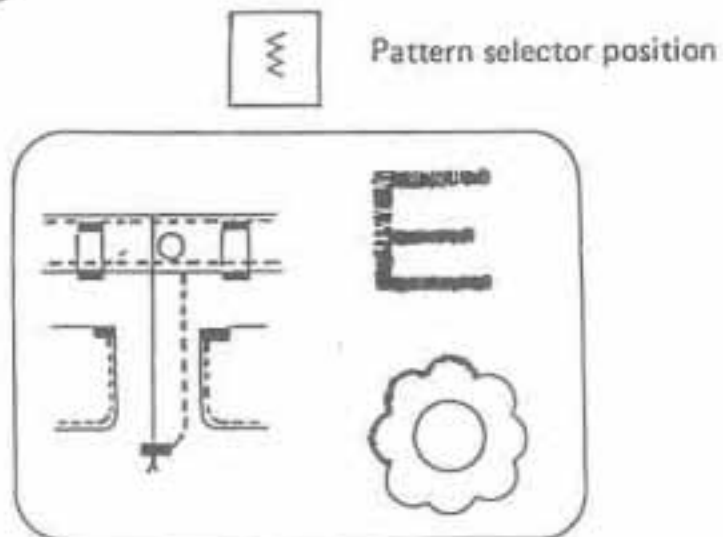

Satin stitching can be used for sewing initials, patterns, applique, etc.

OVERCASTING

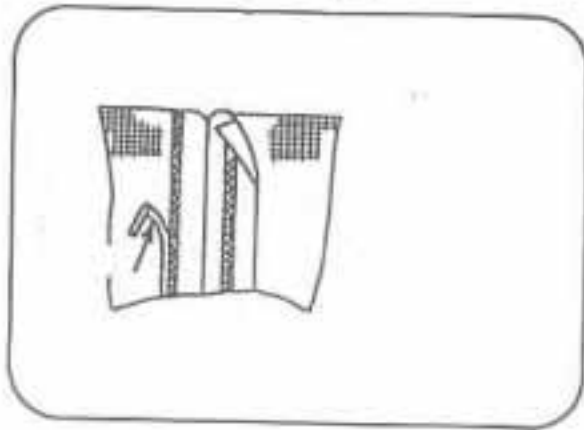

Use these stitches for oversewing rough edges.

STRAIGHT STRETCH STITCH

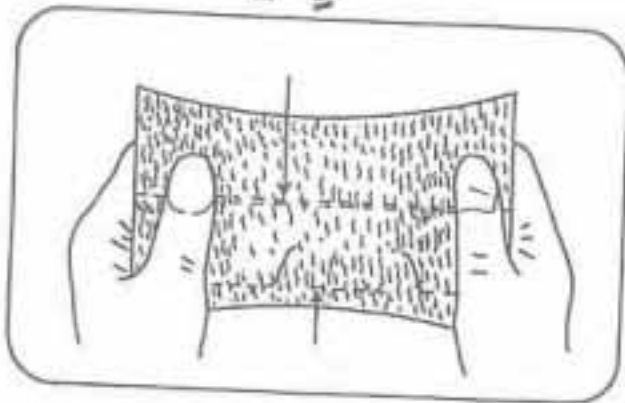

Use this stitch with knitted, tricot or other stretchy fabrics.

The stitch enables your seam to stretch without breaking the thread.

It is also a very strong straight stitch for areas under stress.

BLIND STITCH

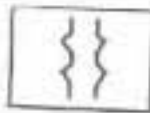

1. Fold fabric as shown.

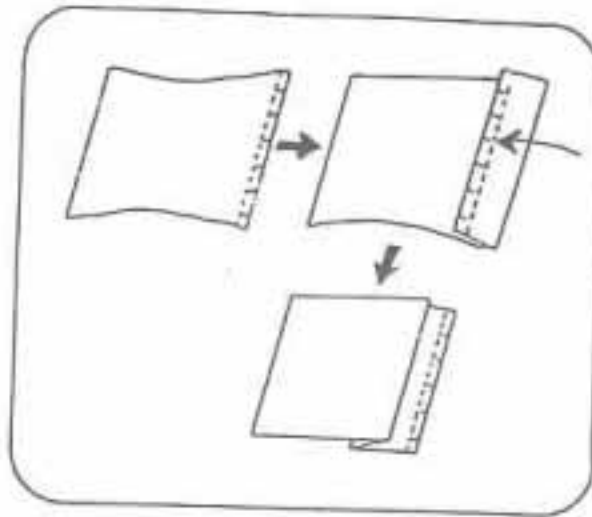

2. To finish seam as shown.

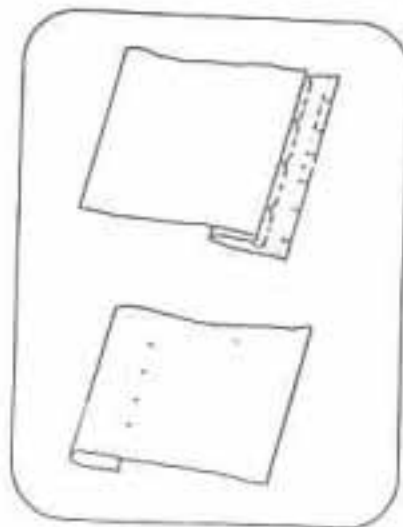

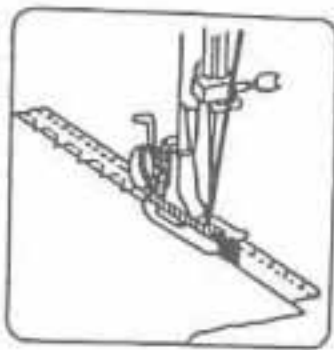

Adjust width and needle position to obtain correct seam.

Needle is not piercing edge of fold at all.

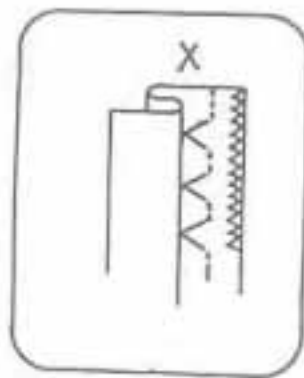

(A)

Needle pierces edge of fold too much.

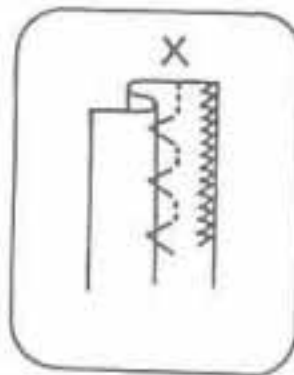

(B)

Correct seam

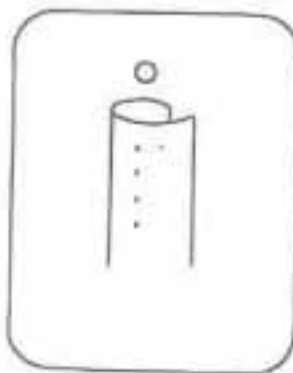

BUTTON SEWING

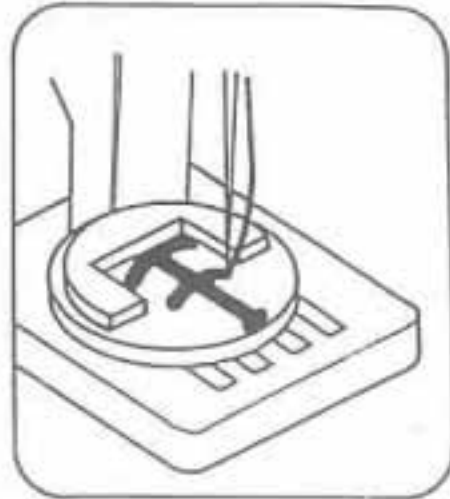
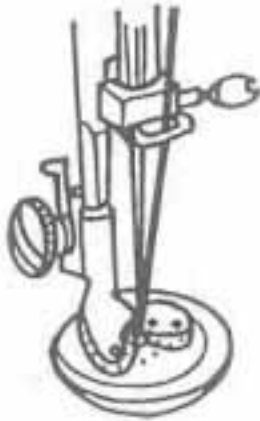

(Use darning plate see page 11)

1. Lower drop feed.
2. Use button presser foot and attach firmly.
3. Place button between presser foot and fabric and lower presser foot.
4. Manually turn hand wheel towards you ensuring that the needle enters into both holes of button without obstruction.
(Increase or decrease width setting).
5. Sew about 7 stitches.
6. Pull both threads to the underside and tie together.

BINDING

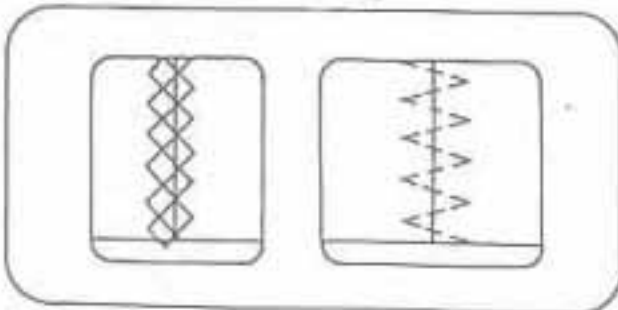

To sew fabrics edge to edge select the multi zig-zag stitch.

ZIPPER SEWING

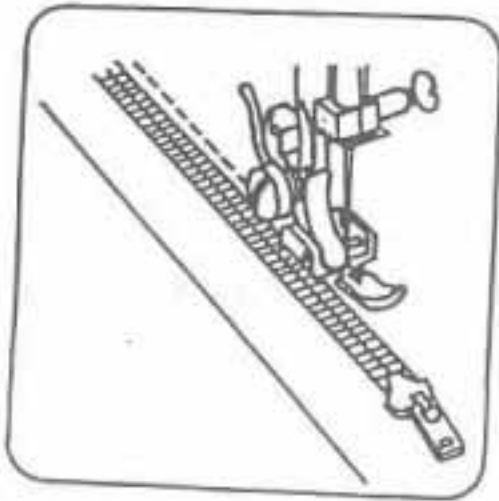

Select straight stitch.

1. Fold the fabric about 2cm and place fabric under foot.
2. Zipper foot is designed to sew close to a raised edge preventing sewing on zipper.

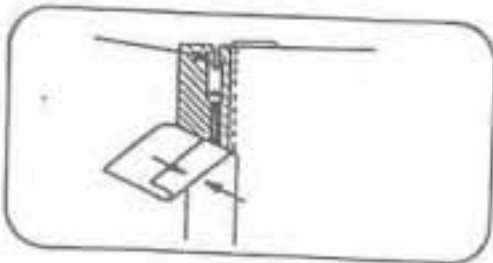



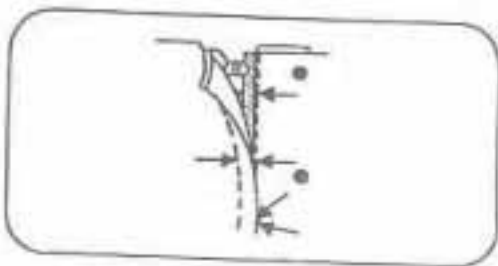





1. To sew the left side of the zipper, set the zipper foot on the left side of the needle.
2. To sew the right side of the zipper bring the foot to the right side of the needle.



sew as illustrated.

BUTTON HOLE SEWING

Select stitch length dial in area indicated.

Pattern selector dial	Steps	Settings
		<ol style="list-style-type: none"> 1. Set dial to "1" position. 2. Sew left side. 3. Raise the needle
		<ol style="list-style-type: none"> 4. Set dial to "2" position. 5. Sew 5-6 stitches. 6. Raise the needle
		<ol style="list-style-type: none"> 7. Set dial to "3" position. 8. Sew right side. 9. Raise the needle
		<ol style="list-style-type: none"> 10. Set dial to "4" position. 11. Sew 5-6 stitches. 12. Raise the needle

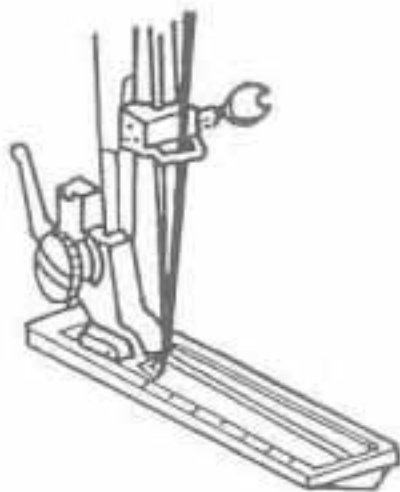

Before sewing fit button-hole foot as shown.

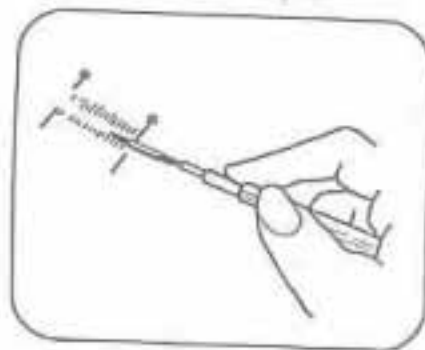

Cut buttonhole along centre with cutter as shown.

HEMMING

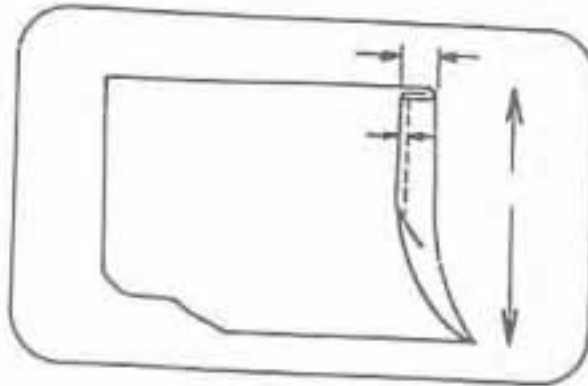

1. Raise the foot and the needle to its highest position. Replace the foot with the hemmer foot.
2. Fold over the fabric edge by about 3mm and place it under the foot. Secure the folded edge with a few stitches. Take out the workpiece and draw the hem into the hemmer foot by pulling the threads.

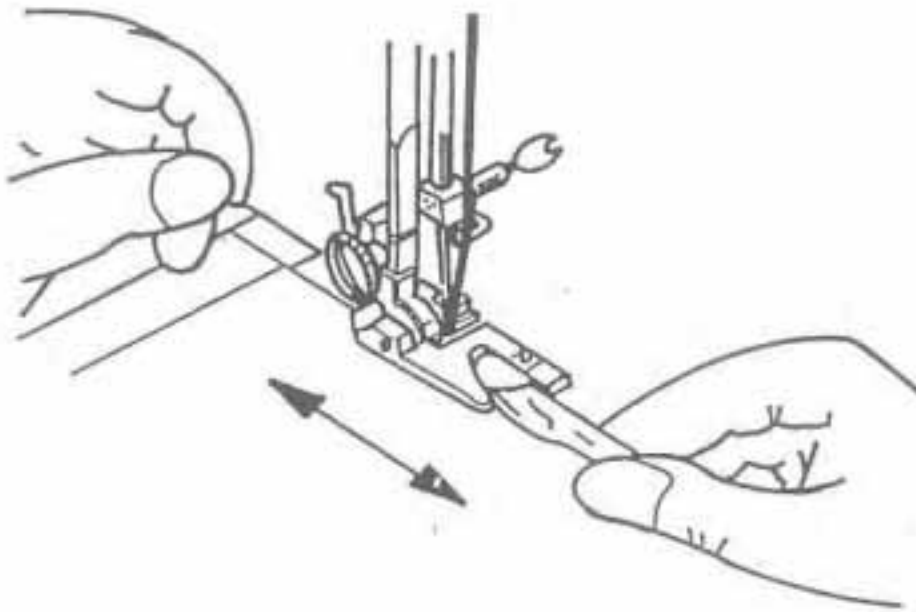

3. Lower the foot and sew the hem.
4. During sewing, fold the fabric to the left a little and allow it to run into the hemmer foot.
5. Make sure that the fabric does not move under the right half of the foot. The fabric must be fed into the scroll of the hemmer sufficiently so that the work-piece edge runs freely through the groove under the foot.

Only suitable materials can be used and some practice may be necessary to achieve best results.

TWIN NEEDLE

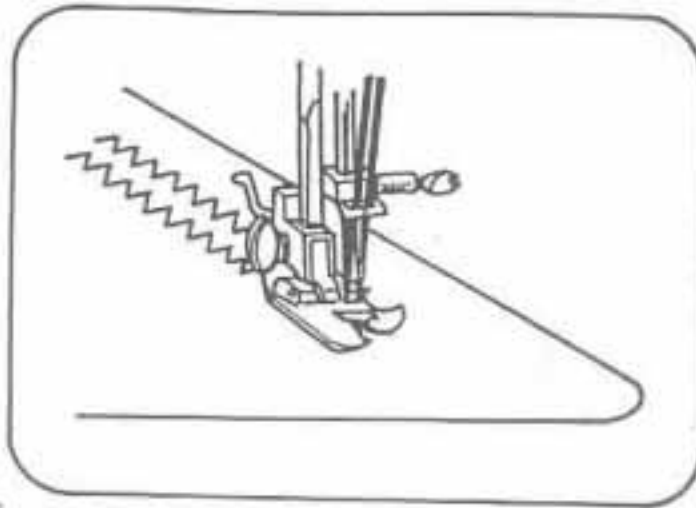

Thread machine as for normal sewing passing both threads through the same procedure;

NB. Sewing width should not exceed the third widest stitch width, exceeding this will result in breaking of needles.

EMBROIDERY

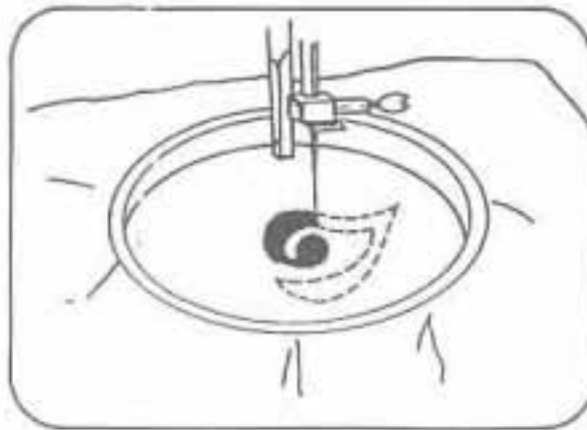

(Use darning plate see page 11)

Lower feed dog and move hooped fabric slowly to form the desired effect.

QUILTER

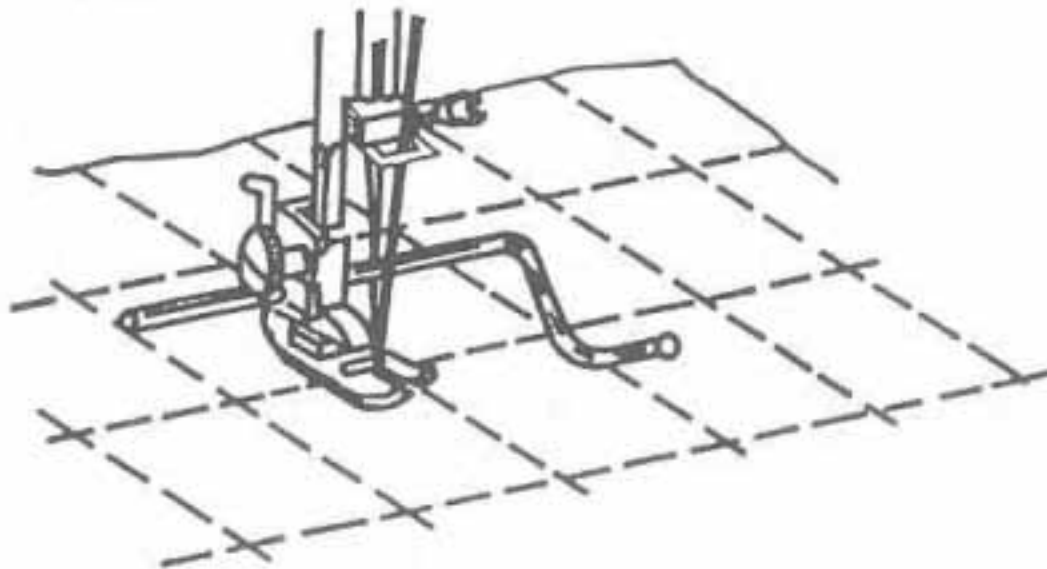

1. Insert supporter of quilter.
2. Move quilter and adjust stitch distance.

SEAM GUIDE

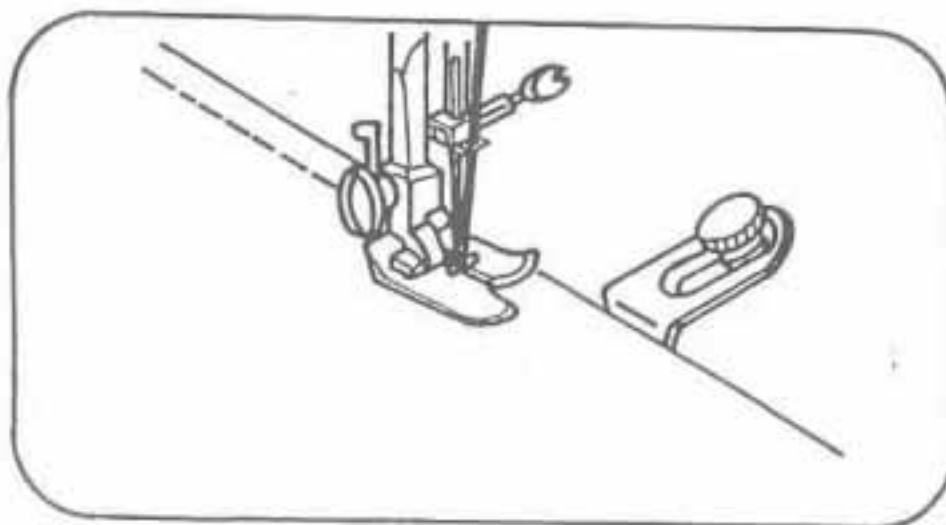

1. Use seam guide when sewing a long seam of regular distance from edge of material.
2. Set guide in hole on bed, at right of needle plate, and adjust distance.
3. Run machine with edge of material touching guide. Position cloth guide at an angle to sew a curved seam.

MAINTENANCE (CLEANING AND OILING)

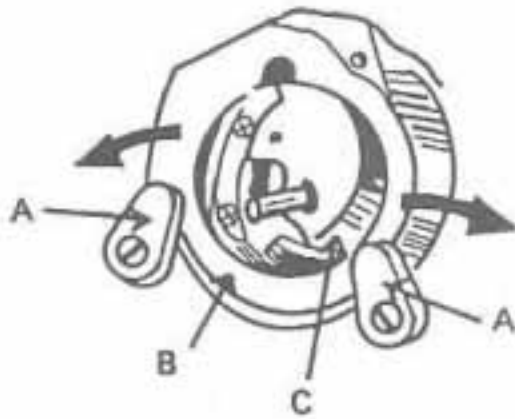

1. Raise needle to its highest position.
2. Take out bobbin case.
3. Turn latch knob A as illustrated.
4. Take off shuttle race cover,
5. Take out shuttle hook.
6. Clean and oil shuttle race and hook, then replace in the reverse order.

Cleaning shuttle race

- (A) Latch knob
- (B) Shuttle race cover
- (C) Shuttle hook

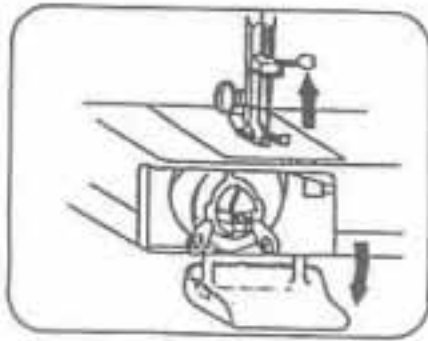

Open face cover and oil points indicated.

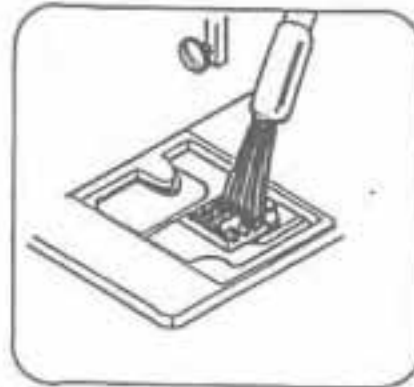

Cleaning feed dog

CHECKING PERFORMANCE PROBLEMS WHAT TO DO

PROBLEM	PROBABLE CAUSE	CORRECTION
Fabric not moving	<ul style="list-style-type: none"> - Feed dog down. - Machine not moving. - Stitch length dial in 0 position. - Light pressure on presser foot. 	<ul style="list-style-type: none"> - Raise feed dog. - Moving stop motion. - Moving dial to 1-4. - Increase pressure on presser foot.
Breaking Needle	<ul style="list-style-type: none"> - Incorrect setting of needle. - Needle bent. - Pulling fabric. - Incorrect using needle, thread and fabric. 	<ul style="list-style-type: none"> - Reset needle. - Replace new needle. - Do not pull fabric. - Correct using needle, thread, and fabric.
Breaking Upper Thread	<ul style="list-style-type: none"> - Incorrect position of zigzag width dial. - Improper threading. - Tight upper thread tension. - Needle bent. - Nicks or burrs on shuttle. 	<ul style="list-style-type: none"> - Moving to correct position. - Rethread machine. - Loosen upper thread tension. - Replace new needle. - Replace shuttle, or polish off burrs completely.
Breaking Bobbin Thread	<ul style="list-style-type: none"> - Tight bobbin thread tension. - Incorrect setting of needle. - Improper threading. - Dust and thread in shuttle. 	<ul style="list-style-type: none"> - Loosen bobbin thread tension. - Reset needle. - Rethread machine. - Clean shuttle.
Machine Jamming Knocking Noise	<ul style="list-style-type: none"> - No oil. - Dust and thread in shuttle. 	<ul style="list-style-type: none"> - Need oil. - Clean shuttle.
Puckering	<ul style="list-style-type: none"> - Tension too tight. - Sewing foot pressure too strong. - Incorrect using fabric, needle, and thread. 	<ul style="list-style-type: none"> - Reset. - Regulating sewing foot pressure. - Correct using fabric, needle and thread.

Free Manuals Download Website

<http://myh66.com>

<http://usermanuals.us>

<http://www.somanuals.com>

<http://www.4manuals.cc>

<http://www.manual-lib.com>

<http://www.404manual.com>

<http://www.luxmanual.com>

<http://aubethermostatmanual.com>

Golf course search by state

<http://golfingnear.com>

Email search by domain

<http://emailbydomain.com>

Auto manuals search

<http://auto.somanuals.com>

TV manuals search

<http://tv.somanuals.com>