

# RICCAR®

## VIBRANCE

R20S, R20D, R20P & R20UP

Owner's Manual





**Getting Started**

Important Safety Instructions .....	2
Polarization Instructions.....	3
State of California Proposition 65 Warnings .....	3
Description of the Vacuum .....	4
Assembling the Vacuum.....	6

**Operation**

Unwinding the Power Cord .....	7
Reclining the Handle .....	7
Turning the Vacuum On/Off .....	7
Using the Carpet/Floor Selector .....	8
Edge Cleaning .....	8
Automatic Carpet Height Adjustment .....	8
Vacuuming Under Furniture .....	9
Carrying the Vacuum .....	9

**Attachment Cleaning**

Wand Cleaning .....	10
Adjusting the Suction Power for Tool Cleaning .....	10
Cleaning Tools .....	11

**Maintenance and Care**

Annual Checkup .....	12
Power Cord Care .....	12
When to Change the Vacuum Bag .....	13
Replacing the Vacuum Bag .....	14
When to Change the Filters .....	15
Replacing the HEPA Media or Foam Filter .....	15
Replacing the Electrostatic Secondary Filter .....	16
Jammed Brushroll .....	17
Lifetime Belt .....	17
Removing and Reinstalling the Bottom Plate .....	18
Unclogging the Nozzle and Hose .....	19
Thermal Motor Protection .....	20

**Problem Solving Guide**

Troubleshooting .....	21
Visit Riccar Vacuums Online .....	21
How to Contact Your Authorized Retailer .....	21
Key Replacement Parts .....	21
For Best Performance .....	21

<b>Warranty</b> .....	<b>22</b>
-----------------------	-----------

# IMPORTANT SAFETY INSTRUCTIONS

---

When using an electrical appliance, basic precautions should always be followed, including the following:

## READ ALL INSTRUCTIONS BEFORE USING THIS APPLIANCE

**IMPORTANT:** The manufacturer cannot accept responsibility for damage caused when the appliance is not used according to the instructions or for uses other than those for which it was intended.

### To reduce the risk of fire, electric shock or injury:

- Do not leave appliance when plugged in. Unplug from outlet when not in use and before servicing.
- Do not use outdoors or on wet surfaces.
- Do not allow to be used as a toy. Close attention is necessary when used by or near children.
- Use only as described in this manual. Use only manufacturer's recommended attachments.
- Do not use with damaged cord or plug. If appliance is not working as it should, has been dropped, damaged, left outdoors, or dropped into water, return it to your Authorized Riccar Retailer for service.
- Do not pull or carry by cord, use cord as a handle, close a door on the cord, or pull cord around sharp edges or corners. Do not run appliance over cord. Keep cord away from heated surfaces.
- Do not unplug by pulling on cord. To unplug, grasp the plug, not the cord.
- Do not handle plug or appliance with wet hands.
- Do not put any object into openings. Do not use with any opening blocked; keep free of dust, lint, hair and anything that may reduce air flow.
- Keep hair, loose clothing, fingers and all parts of body away from openings and moving parts.
- Do not pick up anything that is burning or smoking, such as cigarettes, matches or hot ashes.
- Do not use without vacuum bag and/or filters in place.
- Turn off all controls before unplugging.
- Use extra care when cleaning on stairs.
- Do not use to pick up flammable or combustible liquids such as gasoline or use in areas where they may be present.
- Do not attempt to service the unit while appliance is plugged in.

## SAVE THESE INSTRUCTIONS.

# POLARIZATION INSTRUCTIONS

---

## Power Cord, 2-Wire Polarized Cord

To reduce the risk of electric shock, this product is equipped with a polarized alternating current line plug (a plug having one blade wider than the other). This plug will fit into the power outlet only one way. This is a safety feature. If you are unable to insert the plug fully into the outlet, try reversing the plug. If the plug should still fail to fit, contact a qualified electrician to replace the obsolete outlet. Do not defeat the safety purpose of the polarized plug.

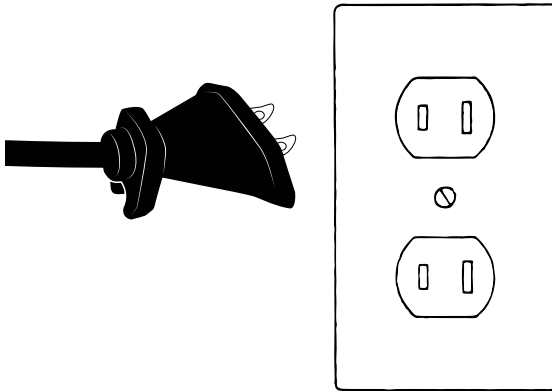

## State of California Proposition 65 Warnings:

**WARNING:** This product contains one or more chemicals known to the State of California to cause cancer.

**WARNING:** This product contains one or more chemicals known to the State of California to cause birth defects or other reproductive harm.

# DESCRIPTION OF THE VACUUM

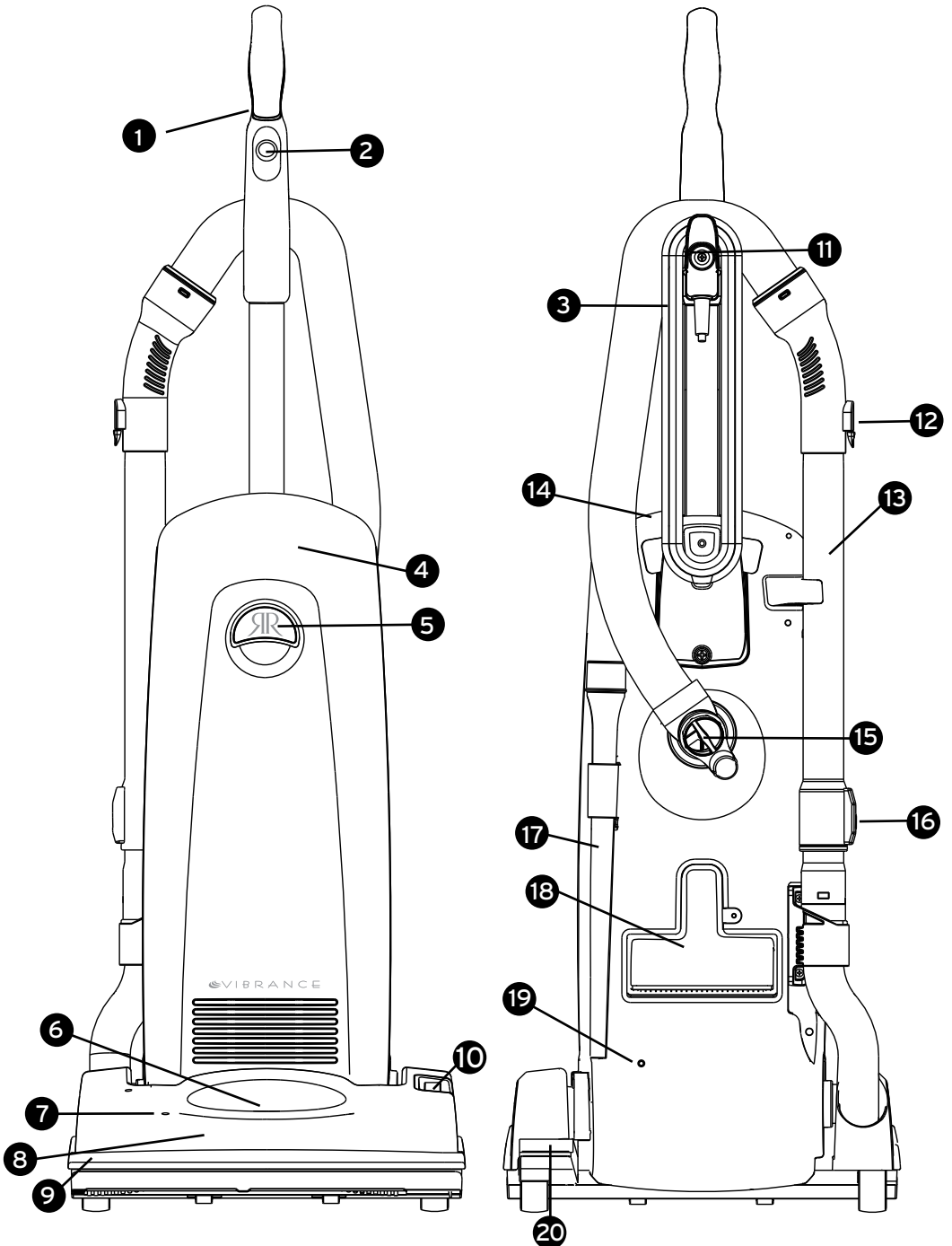

# DESCRIPTION OF THE VACUUM

---

- 1 Ergonomic Handle
- 2 Main On/Off Power Switch
- 3 Power Cord
- 4 Carrying Handle (Located Behind Bag Compartment Cover)
- 5 Bag Compartment Latch (to Replace Vacuum Bag and Filters)
- 6 Xenon Headlight
- 7 Brushroll Jam Indicator (models R20P and R20UP)
- 8 Vacuum Nozzle
- 9 Furniture Guard
- 10 Carpet/Floor Selector (models R20D, R20P and R20UP)
- 11 Quick Release Upper Cord Hook
- 12 Wand Release Button
- 13 Telescopic Wand
- 14 Full Bag Indicator (models R20D, R20P and R20UP)
- 15 Suction Control Dial
- 16 Wand Extension Button
- 17 Crevice Tool
- 18 Combination Dusting/Upholstery Brush
- 19 Thermal Motor Protection Reset Button
- 20 Handle Release Pedal

# ASSEMBLING THE VACUUM

## Attaching the Handle to the Vacuum

NOTE: Do not plug in the vacuum until it is completely assembled.

The vacuum cleaner and the handle are packed separately.

- Remove the handle screw (Fig.1). Then position the handle behind the vacuum cleaner and level with the top of the unit. Hold the power cord down and away from the vacuum while the handle is being attached. Make sure that the switch on the handle is positioned toward the front of the vacuum cleaner.
- On the bottom of the handle are two “T-shaped” rails that slide forward onto two guides located on the top of the vacuum cleaner. Line up the handle so that the “T-shaped” rails will slide into the guides and push the handle downward into the vacuum (Fig. 2).
- Insert the handle screw and tighten securely (Fig. 3).
- Remove the bag compartment cover to ensure a vacuum bag is in place.
- Your vacuum is now ready for use.
- If storing the vacuum, wrap the cord clockwise around the top and bottom cord hooks. Fasten the plug to the wrapped cord using the channel on the plug.

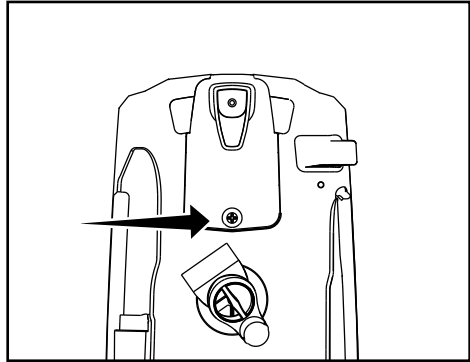

Fig. 1

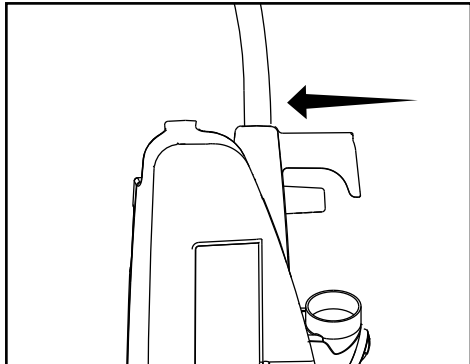

Fig. 2

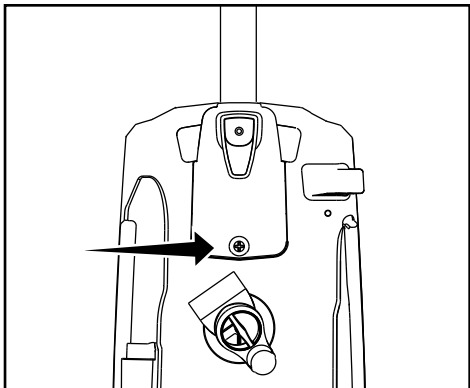

Fig. 3



This vacuum is intended for household use only.

## Unwinding the Power Cord

- The Quick Release Upper Cord Hook rotates to allow for quick access to the power cord. Turn the Upper Cord Hook downward and you can quickly drop the power cord to the floor without unwinding it from the cord hooks (Fig. 1).
- When storing the vacuum cleaner turn the Quick Release Upper Cord Hook to the upright position and wrap the power cord around the cord storage hooks.

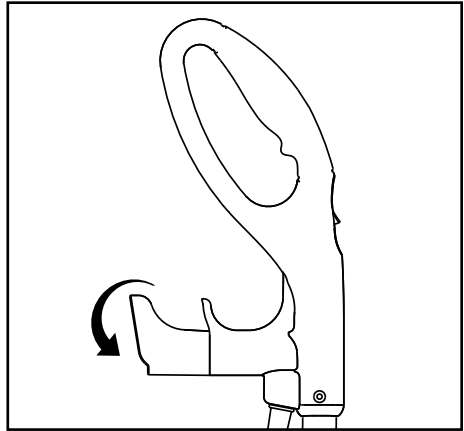

Fig. 1

## Reclining the Handle

- Press the Handle Release Pedal with your foot to recline the handle (Fig. 2).

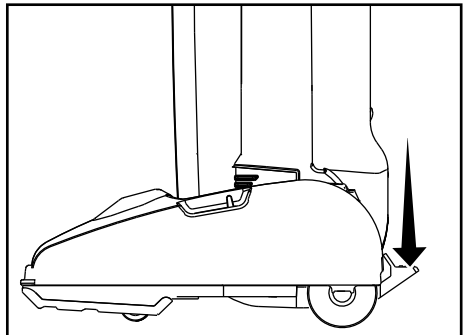

Fig. 2

## Turning the Vacuum On/Off

- To turn the vacuum cleaner on, press the On/Off Switch located on the handle to the "On" position (Fig. 3).
- To stop the vacuum cleaner, press the On/Off switch to the "Off" position.
- Always turn the vacuum cleaner off before unplugging it from the electrical outlet.

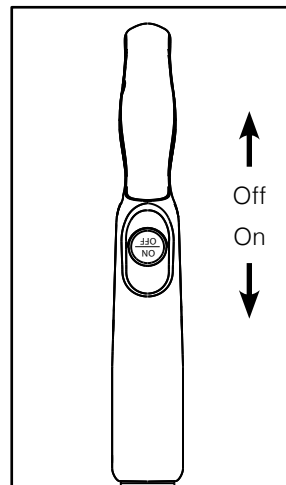

Fig. 3

# OPERATION

---

## Using the Carpet/Floor Selector (models R20D, R20P and R20UP)

### To Vacuum Carpet:

For carpet cleaning, slide the Carpet/Floor Selector toward the back of the nozzle so that it reads "Carpet" (Fig. 1).

### To Vacuum Hard Surfaces and Use Tools:

For cleaning bare floors or using tools, slide the Carpet/Floor Selector toward the front of the nozzle so that it reads "Floor & Tools". This prevents the brushroll from spinning and potentially damaging your floor (Fig. 2).

### Edge Cleaning

The edge cleaning feature provides improved cleaning of carpets near walls and stationary furniture. For maximum edge cleaning, place the right side of the nozzle against the wall or furniture.

### Automatic Carpet Height Adjustment

Your vacuum cleaner is designed with an automatic self-adjusting nozzle. No manual adjustments are required. The height of the nozzle automatically adjusts to the carpet pile height. This self-adjusting feature allows the nozzle to float evenly over all carpet pile surfaces.

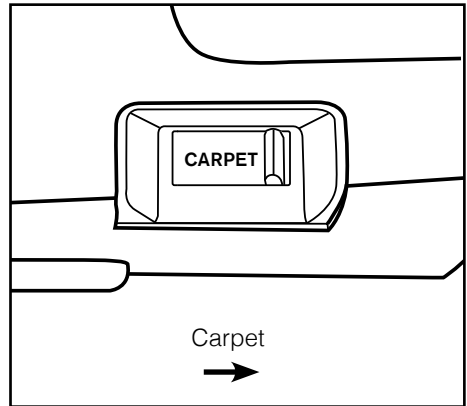

Fig. 1

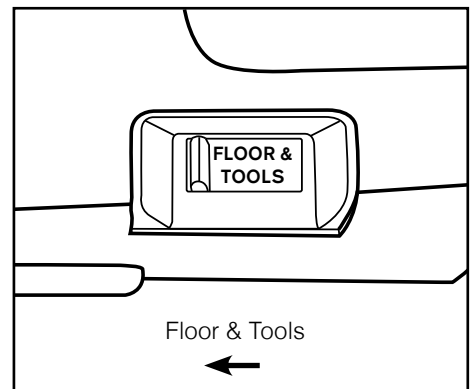

Fig. 2

## Vacuuming Under Furniture

Your vacuum will lie flat on the floor for effective cleaning under beds and tables.

- Press the Handle Release Pedal once for normal vacuuming (Fig. 1).
- Press the Handle Release Pedal a second time to enable the vacuum to lie flat on the floor (Fig. 2).

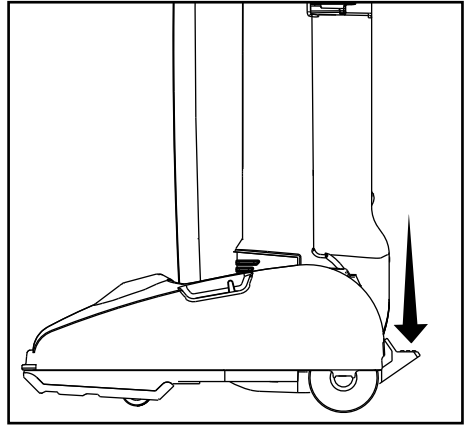

Fig. 1

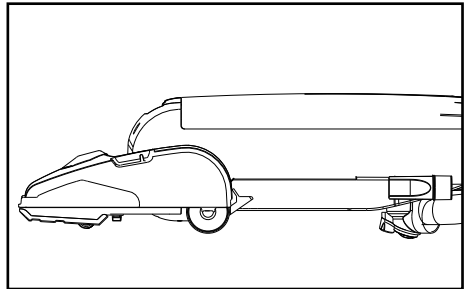

Fig. 2

## Carrying the Vacuum

To safely transport your vacuum, especially when carrying the vacuum up and down stairs, use the Carrying Handle located at the top of the bag compartment behind the bag compartment cover (Fig. 3).

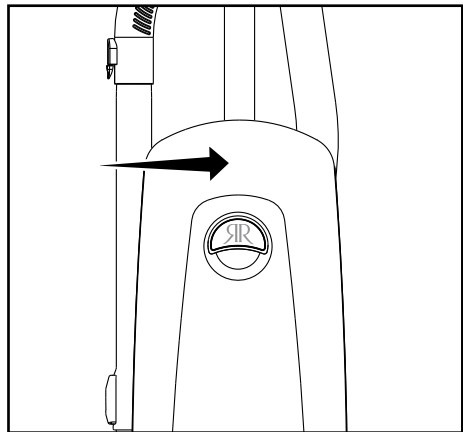

Fig. 3

## ATTACHMENT CLEANING

Your vacuum is a comprehensive cleaning system equipped with an upholstery tool, dusting brush, crevice tool, telescopic wand and a stretch hose.

### Wand Cleaning

- Remove the Telescopic Wand from the body of the vacuum by pulling it up and out of the holder.
- Extend the wand by sliding the Wand Extension Button forward while extending the wand to desired length.
- Attach any of the tools to the end of the Telescopic Wand.
- When finished with wand cleaning, insert the wand back into the vacuum and secure it by pushing the curved handle into the holder.

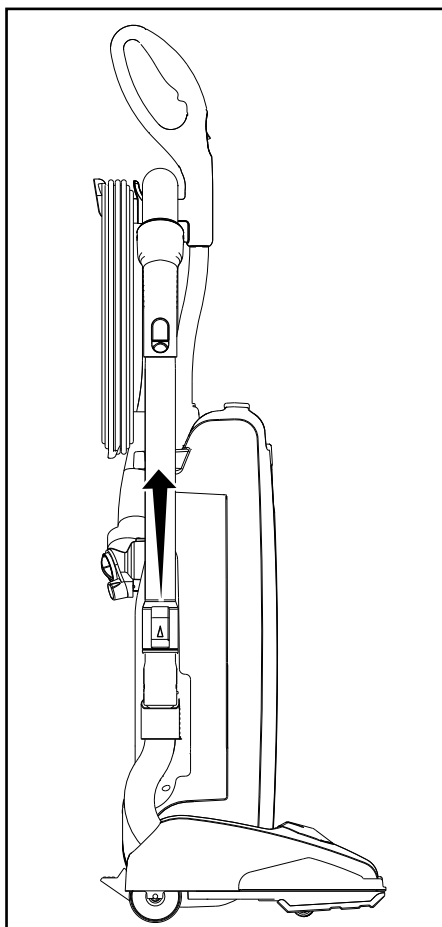

### Adjusting the Suction Power for Tool Cleaning

Full suction power may be too strong for some cleaning situations. For example, reduced suction power would be appropriate for cleaning sheer curtains.

- On the back of the vacuum, locate the Suction Control Dial and turn it to the desired position. This reduces the suction power coming through the hose. Close the Suction Control Dial when finished to restore full suction power.

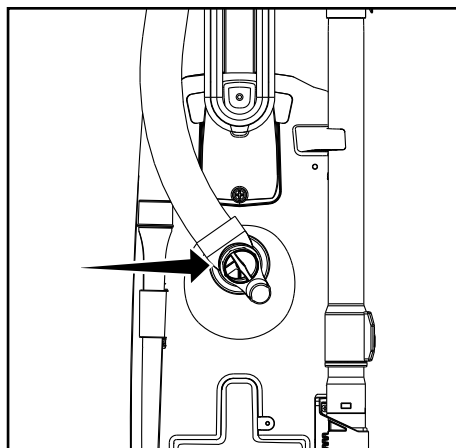

# ATTACHMENT CLEANING

## Cleaning Tools

Your vacuum is equipped with a dusting brush, upholstery brush and crevice tool.

- Turn the Carpet/Floor Selector on the nozzle to the “Floor & Tools” position (models R20D, R20P and R20UP only) and remove the cleaning wand from the vacuum.
- Insert any of the tools onto the end of the wand.

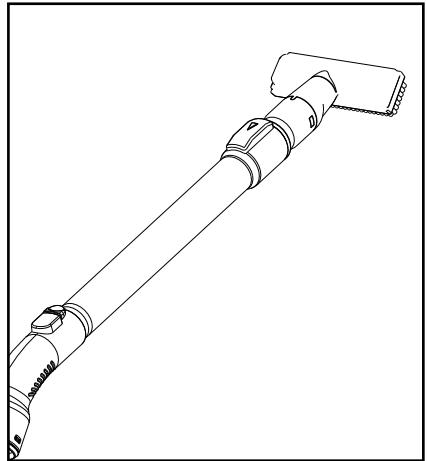

Wand with Dusting Brush

## Dusting Brush

Ideal for table tops, shelves, blinds or hard surface floors.

## Upholstery Tool

Remove the dusting brush clip for upholstery cleaning. Ideal for soft surfaces like chairs and couches.

## Crevice Tool

Ideal for tight places like between seat cushions or corners.

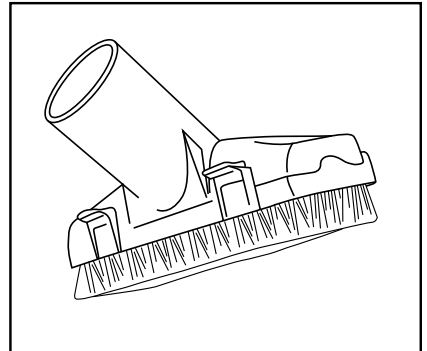

Dusting Brush

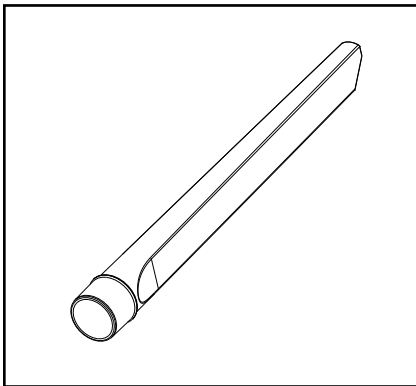

Crevice Tool

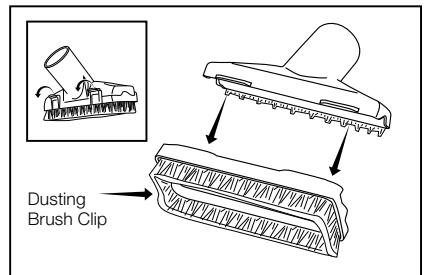

Upholstery Tool/Dusting Brush

# MAINTENANCE AND CARE

---

## Annual Checkup

To keep your vacuum in peak operating condition, it is recommended you bring your vacuum to an Authorized Riccar Retailer for an annual checkup. Your retailer will conduct a comprehensive examination to ensure your vacuum is in top operating condition.

## Power Cord Care

- If cord or plug has any apparent damage, refrain from using the vacuum. Please visit an Authorized Riccar Retailer for a new cord or plug.
- When vacuum is in use, hold the cord to keep from running over it.
- Avoid obstructions and do not pull cord around sharp edges or corners.
- Always keep cord away from heated surfaces and never close doors on it as this may cause damage to the wiring.
- To unplug, always grasp the plug, not the cord.

## When to Change the Vacuum Bag (models R20D, R20P and R20UP)

The Full Bag Indicator Light is designed to show when the bag is full or when there is a clog in the vacuum.

The system measures airflow and alerts the user when airflow is significantly reduced – most commonly from a full bag or a clog.

The light could also come on when vacuuming fine powders such as flour or drywall dust. These materials can quickly block the bag pores, significantly reducing airflow before the bag is actually full. The vacuum bag should still be changed.

The light may also come on during attachment cleaning. If the light goes off when attachments are no longer in use, the vacuum bag does not need to be changed.

### For model R20S:

To maintain optimal performance change your vacuum bag once a month or when the bag is two-thirds full.

**NOTE:** The vacuum bags are disposable and intended to only be used once. Do not attempt to reuse the bag as suction and filtration performance will be greatly reduced.

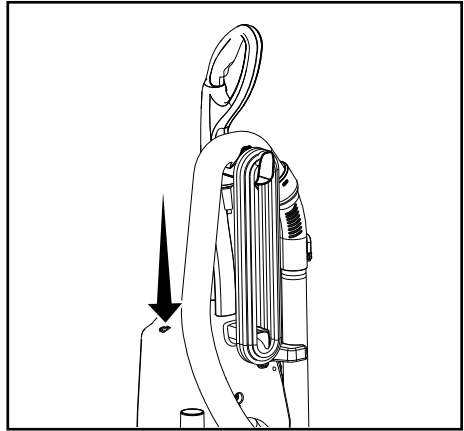

# MAINTENANCE AND CARE

## Replacing the Vacuum Bag

NOTE: Unplug the vacuum cleaner from the electrical outlet before changing the bag.

- Open the bag compartment by lifting up the latch on the bag compartment cover.
- Remove the used vacuum bag by pulling the red bag collar tab away from the vacuum (Fig. 1). Slide the used bag out of the holder which automatically seals the bag (Fig 2). Discard the used bag.
- To install a new bag, slide the bottom of the red bag collar into the bag holder until it “snaps” into place (Fig. 3).
- Push the top of the bag collar upward until the bag holder “snaps” into place on the vacuum (Fig. 4).
- Tuck the bag corners into the bag compartment before replacing the bag compartment cover.
- Replace the bag compartment cover.

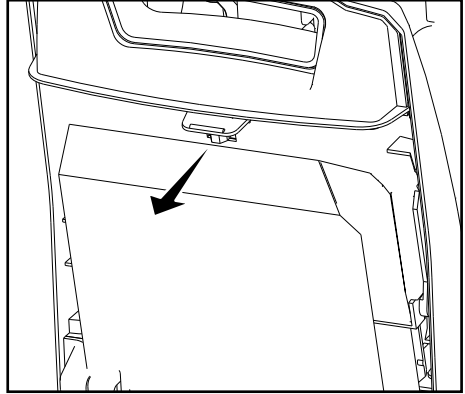

Fig. 1

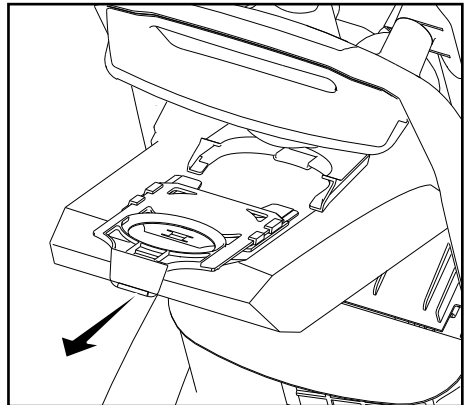

Fig. 2

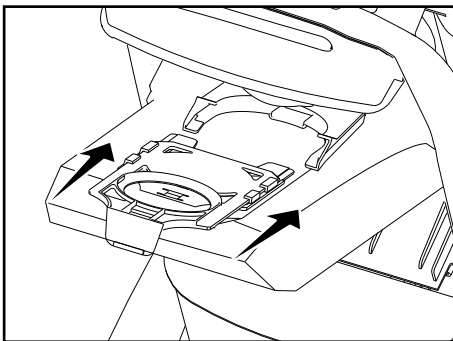

Fig. 3

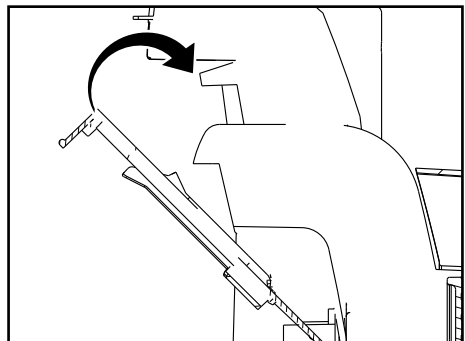

Fig. 4



## When to Change the Filters

At minimum, it's recommended to replace the filters once a year or after using 12 vacuum bags, whichever comes first.

If someone in your household is sensitive to airborne allergens, it is recommended to change the filters after every six vacuum bags.

## Replacing the HEPA Media or Foam Filter

Depending on the model, your vacuum is equipped with either a HEPA media filter or a foam filter.

**NOTE:** Unplug the vacuum cleaner from the electrical outlet before changing the filters.

- Remove the bag compartment cover.
- Locate the filter on the front of the vacuum.
- Remove the used filter and throw away. Filters cannot be washed and reused.
- Press a new filter into place on the front of the vacuum.
- Replace the bag compartment cover.

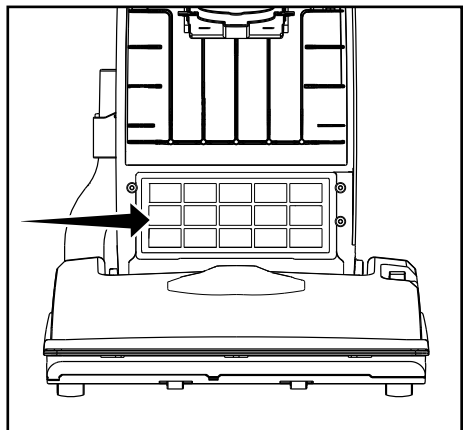
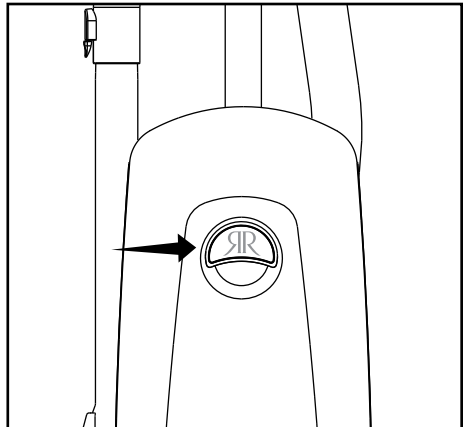

# MAINTENANCE AND CARE

---

## Replacing the Electrostatic Secondary Filter

**NOTE:** Unplug the vacuum cleaner from the electrical outlet before changing the filters.

The electrostatic secondary filter protects the motor from dust and dirt. Before installing a new vacuum bag, check the filter. Accumulated dirt in the bag compartment will be collected on this filter and may restrict motor performance when the filter becomes dirty.

- Remove the bag compartment cover.
- Locate the secondary filter on the bottom of the bag compartment.
- Slide the used secondary filter out from under the bag support.
- Insert a new filter by sliding it under the bag support.
- Replace the bag compartment cover.

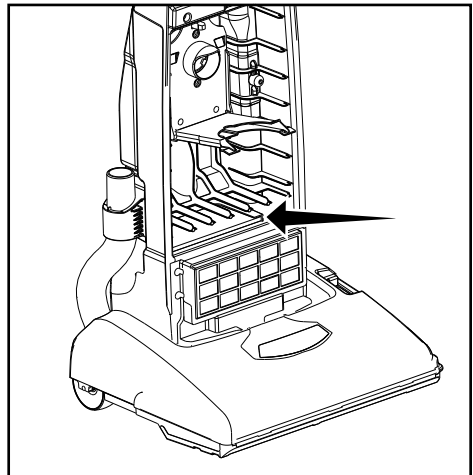
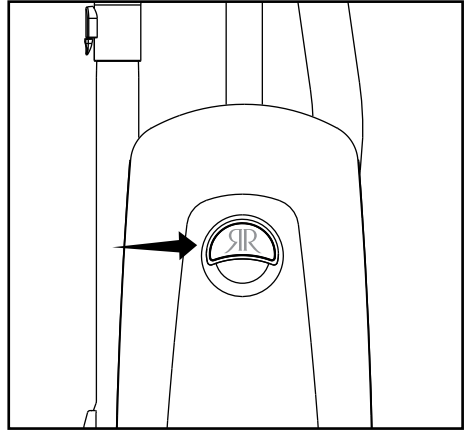

## Jammed Brushroll (Models R20P and R20UP)

**CAUTION!** To Reduce the Risk of Injury From Moving Parts, Unplug Before Servicing.

If an object, such as a throw rug or article of clothing is ever picked up into your vacuum, the vacuum will sense this Jammed Brushroll condition and turn off the brushroll. When this happens, the Brushroll Warning light on the top of the nozzle will light up in red.

- Turn off the vacuum.
- Remove the cause of the jam.
- Turn the vacuum back on.
- If the brushroll is free of any object and the Brushroll Warning light is still lit, please take it to an Authorized Riccar Retailer for service.

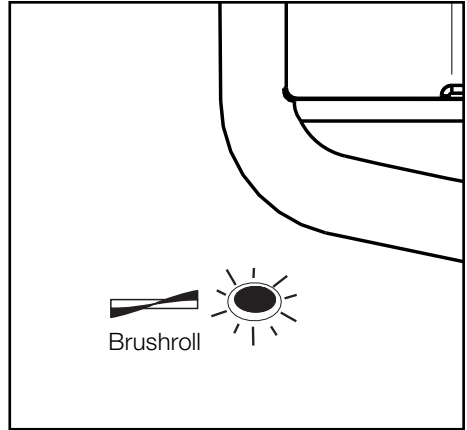

Red Warning Light Indicates a Jammed Brushroll Condition

## Lifetime Belt (models R20P and R20UP)

Your vacuum belt is covered with a lifetime warranty. Should the vacuum belt break, simply bring your vacuum to your Authorized Riccar Retailer for a free replacement.

# MAINTENANCE AND CARE

---

## Removing and Reinstalling the Bottom Plate

**WARNING!** To Reduce the Risk of Electrical Shock or Injury From Moving Parts, Unplug Before Servicing or Cleaning.

- Press the handle release pedal twice and place the vacuum cleaner in the flat position.
- Turn the vacuum cleaner over, exposing the bottom plate.
- Slide the two locking latches toward the center.
- Press the tabs inward on each side and remove the bottom plate.
- Reinstall by placing the lower edge of the bottom plate along the lower edge of the nozzle. Snap the bottom plate into place. Slide the locking latches to the outside edges.

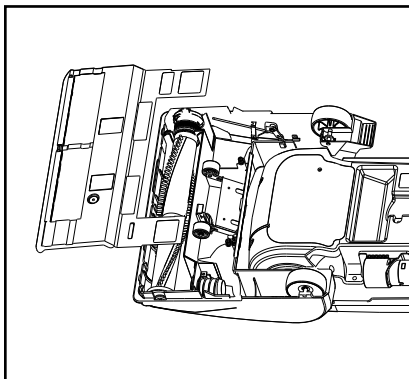
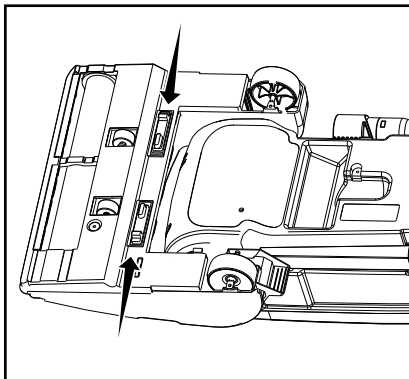

## Unclogging the Nozzle and Hose

**WARNING!** To Reduce the Risk of Electrical Shock or Injury From Moving Parts, Unplug Before Servicing or Cleaning.

The hose located on the back of the vacuum carries the dirt from the nozzle to the vacuum bag. The hose also functions as the attachment cleaning hose. First check to see that a bag is properly installed.

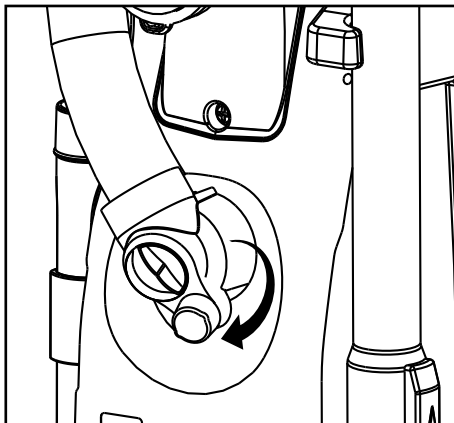

Fig. 1

## If the Hose Becomes Clogged

There are three areas to check if you suspect a clog in the hose:

### Suction Dial

- Turn the Suction Dial to the open position. Remove the clog or blockage (Fig. 1).

### Nozzle Inlet Tube

- Turn the vacuum over and remove the bottom plate (See page 18). Check the nozzle inlet tube for obstructions (Fig. 2). Clear the tube and reinstall the bottom plate.

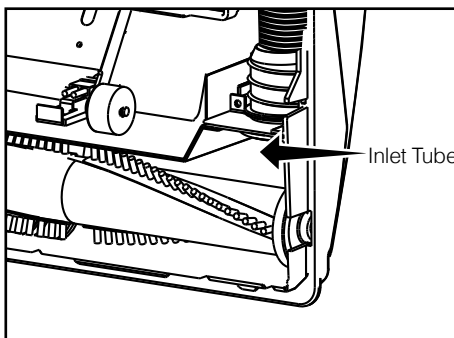

Fig. 2

### Nozzle Hose

- Turn the vacuum over and remove the bottom plate (See page 18). Remove one screw at the base of the nozzle hose (Fig. 3). Clear the hose of blockage and replace the screw. Reinstall the bottom plate.

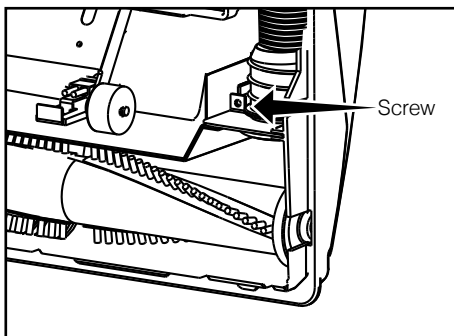

Fig. 3

# MAINTENANCE AND CARE

## Thermal Motor Protection

**WARNING!** To Reduce the Risk of Electrical Shock or Injury From Moving Parts, Unplug Before Servicing or Cleaning.

Your vacuum is equipped with a safeguard to recognize when the vacuum might overheat and shuts off. Common reasons why a vacuum may overheat include operating the vacuum with a full bag or when there is a clog in the vacuum.

Check the headlight to verify that your vacuum shut off due to the thermal motor protection. If when the vacuum is turned on, the motor is off, but the headlight is on then the thermal motor protection system did shut off the vacuum.

If both the motor and the headlight are off, then your vacuum is not working for some other reason, like a pulled plug for example.

If the Thermal Motor Protection System shuts off your vacuum, follow these steps:

- Unplug the vacuum.
- Inspect the vacuum for a full bag condition or a hose clog and correct the problem.
- Locate the Thermal Motor Protection Reset Button on the back of the vacuum. Press the button and resume vacuuming.

If problem continues, contact your Authorized Riccar Retailer.

### Thermal Reset

1. Unplug machine
  2. Locate problem source (clogged hose or full bag)
  3. Correct problem
  4. Press reset button
- If problem persists, consult owner's manual or contact retailer.

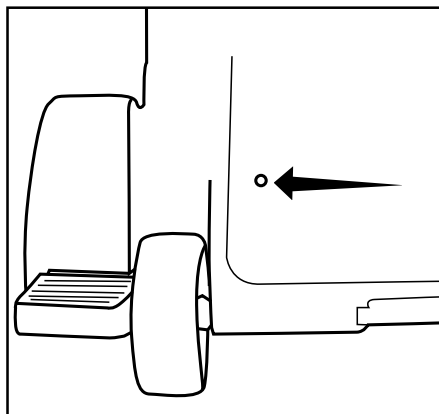

# PROBLEM SOLVING GUIDE

## Troubleshooting

**WARNING!** To Reduce the Risk of Electrical Shock or Injury From Moving Parts, Unplug Before Servicing or Cleaning.

**CAUTION!** To reduce the risk of electric shock, do not handle plug or appliance with wet hands.

PROBLEM	POSSIBLE REASON	POSSIBLE SOLUTION
Vacuum won't turn on	<ul style="list-style-type: none"><li>• Power cord not firmly plugged in</li><li>• Blown fuse or tripped breaker</li><li>• Needs service</li></ul>	<ul style="list-style-type: none"><li>• Plug unit in firmly.</li><li>• Check house fuse or breaker. Replace fuse / reset breaker.</li><li>• Take to an Authorized Riccar Retailer</li></ul>
Vacuum won't pick up or low suction	<ul style="list-style-type: none"><li>• Vacuum bag full</li><li>• Clogged filter</li><li>• Hose clogged</li><li>• Worn brushes</li></ul>	<ul style="list-style-type: none"><li>• Replace bag.</li><li>• Replace filters.</li><li>• Remove obstacle.</li><li>• Replace brush strips.</li></ul>
Dust escaping from vacuum	<ul style="list-style-type: none"><li>• Bag compartment cover is not installed properly.</li><li>• Filters not installed correctly</li></ul>	<ul style="list-style-type: none"><li>• Attach the bag compartment cover.</li><li>• Review filter installation (pages 15-16).</li></ul>

Any other service should be performed by an Authorized Riccar Retailer.  
To locate your nearest Authorized Riccar Retailer, visit our website at [www.Riccar.com](http://www.Riccar.com) or call **888-6-RICCAR**.

## Key Replacement Parts

- Genuine HEPA Media Vacuum Bags: **RMH-6**
- Genuine Vacuum Belts: **R20B-2 (models R20S and R20D)**
- Genuine Filters: **RF20UP (model R20UP)**  
**RF20DP (models R20D and R20P)**  
**RF20S (model R20S)**

## For Best Performance

- Keep your vacuum clean and in good operating condition.
- Change vacuum bags once a month or when the full bag light is illuminated to maximize cleaning performance.
- Always use genuine Riccar vacuum bags and replacement parts. Use of other products may result in poor cleaning performance, potential vacuum cleaner damage and may void vacuum warranty. Genuine products are designed for maximum cleaning performance.
- Have your vacuum checked annually by your Authorized Riccar Retailer.
- Store your vacuum carefully in a dry area.
- For optimum cleaning performance and safety, follow your owner's manual instructions.

# WARRANTY

---

## What is Covered:

This warranty covers any defects in material and workmanship in your new Riccar vacuum and applies exclusively to the original purchaser.

## How Long Coverage Lasts:

Warranty coverage lasts five years for the R20P and R20UP models. Warranty coverage lasts four years for the R20S and R20D models. Household models used commercially are only warranted for 90 days.

## What is Not Covered:

- Damage to the vacuum which occurs from neglect, abuse, alterations, accident, misuse or improper maintenance.
- Normal replacement items: disposable bags, disposable filters, light bulbs, belts (models R20S and R20D) and agitator brushes.

## What We Will Do:

This warranty provides, at no cost to you, all labor and parts to keep this vacuum in correct operating condition during the warranted period.

## How to Get Service:

Warranty service can only be obtained by presenting the vacuum to an Authorized Riccar Retailer. A proof-of-purchase and product serial number will be required before service is rendered. To locate your nearest service center, please call 888-6-RICCAR or visit [www.Riccar.com](http://www.Riccar.com).

THIS WARRANTY IS EXCLUSIVE AND IN LIEU OF ANY AND ALL OTHER WARRANTIES WHETHER WRITTEN, ORAL, EXPRESSED OR IMPLIED, (INCLUDING ANY WARRANTY OF MERCHANTABILITY OR FITNESS FOR A PARTICULAR PURPOSE). THIS WARRANTY DISCLAIMS LIABILITY FOR INCIDENTAL OR CONSEQUENTIAL DAMAGES.

## How State Law Applies:

This warranty gives you specific legal rights, and you may also have other rights which vary from state to state.

Register your warranty online at **[www.Riccar.com](http://www.Riccar.com)**



# OWNER'S WARRANTY INFORMATION

---

*keep this for your records...*

Date of purchase \_\_\_\_\_

Serial number \_\_\_\_\_

Model number \_\_\_\_\_

## **Purchased from:**

Store name \_\_\_\_\_

Address \_\_\_\_\_

City, State, Zip \_\_\_\_\_

Telephone \_\_\_\_\_





RICCAR®  
[www.Riccar.com](http://www.Riccar.com)

## Free Manuals Download Website

<http://myh66.com>

<http://usermanuals.us>

<http://www.somanuals.com>

<http://www.4manuals.cc>

<http://www.manual-lib.com>

<http://www.404manual.com>

<http://www.luxmanual.com>

<http://aubethermostatmanual.com>

Golf course search by state

<http://golfingnear.com>

Email search by domain

<http://emailbydomain.com>

Auto manuals search

<http://auto.somanuals.com>

TV manuals search

<http://tv.somanuals.com>