

RICOH

FT6645/6655

Operating Instructions

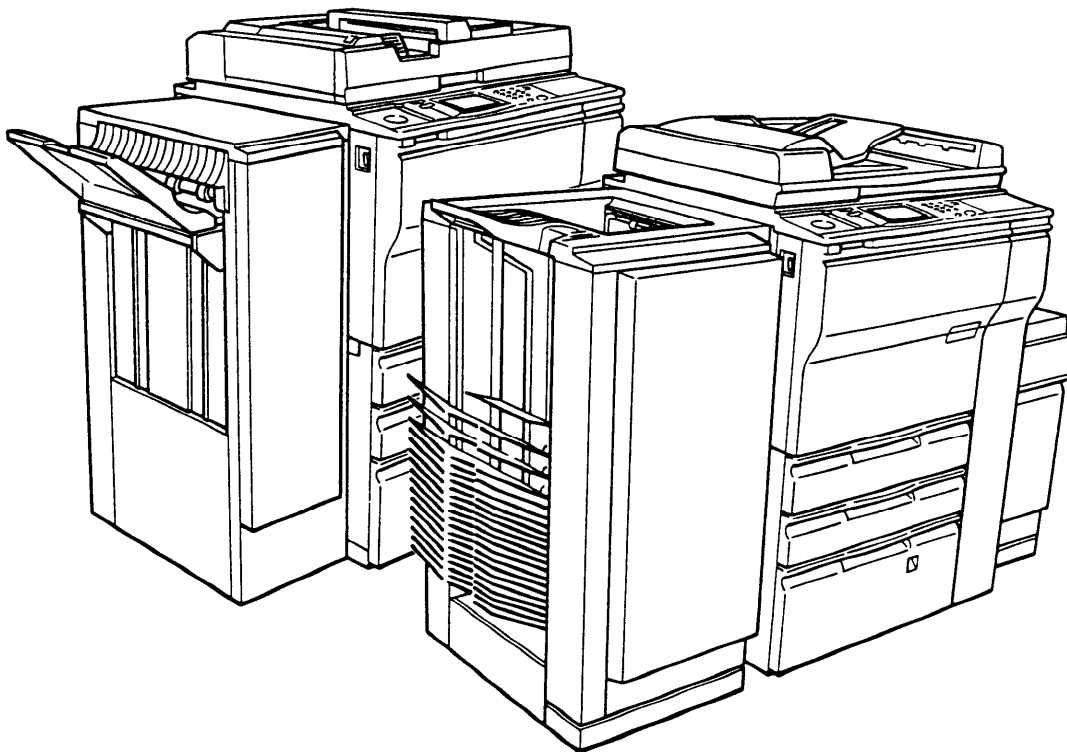

Notes: The model names of the machines do not appear in the following pages.
Check the type of your machine before reading this manual.
(For details, see page 2.)

Type 1 = FT6645

Type 2 = FT6655

Certain types may not be available in some countries. For details, please contact your local dealer.

Note: Certain options may not be available in some countries. For details, please contact your local dealer.

Ricoh shall not be responsible for any damage or expense that may result from the use of parts other than genuine Ricoh parts in your Ricoh office product.

For good copy quality, Ricoh recommends that you use genuine Ricoh toner.

Power Source: 120V, 60 Hz, more than 20A
Please make sure to connect the power cord to a power source as above. For details about power cord, see page iv.

SAFETY INFORMATION

When using your copier, the following safety precautions should always be followed.

Safety During Operation

In this manual, all safety messages are identified by the words "WARNING" and "Caution". These words mean the following:

WARNING:

Important information to alert you to a situation that might cause serious injury and damage to your property if instructions are not followed.

Caution:

Important information that tells how to prevent damage to equipment, or how to avoid a situation that might cause minor injury.

WARNING:

- Since some parts of the copier are supplied with high electrical voltage, touch only the parts specified in this manual and the machine's display.***
- Do not modify or replace any parts other than the ones specified in this manual and the machine's display.***
- Do not incinerate toner or toner containers. Toner dust may ignite when exposed to open flame.***
- Do not store toner where it will be exposed to heat.***
- Do not eat or swallow toner, and keep it out of reach of children.***
- The fusing unit may be very hot. Be careful when handling it.***

Caution:

- While copying, do not turn off the main switch.***
- While copying, do not open the front doors.***
- While copying, do not unplug the power cord.***
- Do not lay anything weighing more than 10 kg (22 lb) on the exposure glass.***
- Keep corrosive liquids, such as acid, off the machine.***
- Do not allow paper clips, staples, or other small metallic objects to fall inside the machine.***

General Safety Information

- Always turn the copier off when you have finished copying for the day, but leave it plugged in.
- When the copier will not be used for a long period, disconnect the power cord.
- If the copier must be transported by vehicle, please contact your service representative.
- When the main switch is in the Stand-by position, the anticondensation heaters are on. In case of emergency, unplug the machine's power cord.
- The main plug on this equipment must be used to disconnect main power.

INSTALLATION REQUIREMENTS

Copier Environment

The installation location should be carefully chosen because environmental conditions greatly affect the performance of a copier.

– Optimum environment conditions –

- Temperature: 10 - 30°C (50 - 86°F)
- Humidity: 15 - 90%
- A strong and level base.
- The copier must be level within 5 mm (0.2") both front to rear and left to right.
- To avoid possible build-up of ozone, make sure to locate this copier in a large well ventilated room which has air turnover of more than 30m³/hr/person.

Environments To Avoid

- Locations exposed to direct sunlight or strong light (more than 1,500 lux).
- Locations directly exposed to cool air from an air conditioner or heated air from a heater. (Sudden temperature changes may cause condensation within the copier.)
- Places where the copier may be subjected to frequent strong vibration.
- Dusty areas.
- Areas with corrosive gases.
- Places higher than 2,000 m (6,500 ft) above sea level.

Power Connection

- Avoid multiwiring.
- Make sure that the wall outlet is near the copier and easily accessible.
- Make sure the plug is firmly inserted in the outlet.
- Voltage must not fluctuate more than 10%.
- Do not set anything on the power cord.

Access To Copier

- Place the copier near the power source, providing clearance as shown:

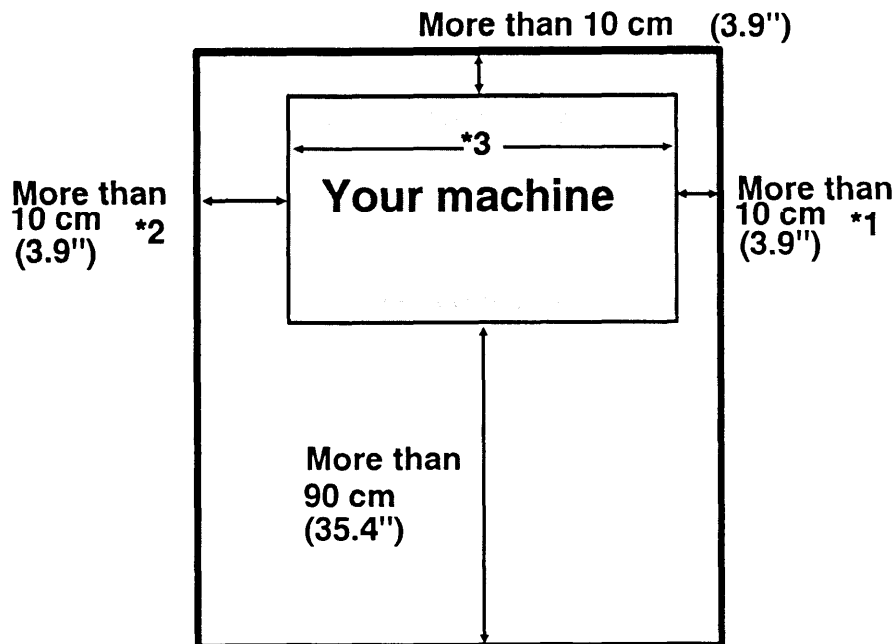

- *1 If the optional 3,500-sheet large capacity tray is not installed, the distance between the wall and the edge of the bypass feed tray must be more than 30 cm.
- *2 If the compact sorter stapler is installed, the distance must be more than 20 cm.
- *3 See page 83.

STORAGE OF SUPPLIES

Storage Of Supplies

Paper Storage

Paper should always be stored properly. Improperly stored paper may result in poor image reproduction, creased copies, and paper misfeeds.

- Avoid storing paper in humid areas. (Under high temperature and high humidity conditions, store copy paper in a vinyl bag.)
- Do not store paper where it will be exposed to heat.
- Store on a flat surface.
- Use older stock first.
- Do not lay heavy objects on paper.
- Keep open reams of paper in the package, and store as you would unopened paper.

Toner Storage

- Store in a cool, dark place.
- Do not store toner where it will be exposed to heat.
- Do not lay anything heavy on toner.

TABLE OF CONTENTS

GUIDE TO COMPONENTS

Copier Type	2
Copier Exterior	3
System Overview	4
Operation Panel	
Key Tops	6
Touch Panel Display	7

WHAT YOU CAN DO WITH THIS COPIER 8

HOW TO SEE THE GUIDANCE DISPLAY

Seeking Guidance In Stand-by	12
Seeking Guidance While Entering Job Settings	13

CHANGING DEFAULT SETTINGS

User Tools	14
How To Access The User Tools	14
1. Auto reset/Auto off	15
2. Select special tray	15
3. Set date/time	16
4. Weekly Timer	16
5. Set operation modes	16
6. Change fixed R/E	17
7. Set standard tray display	17
12. Select ARDF/RDH modes	17
8. Set User Code(s)	18
9. Check/Reset copy count	18
10. Reset data for User Codes	18
11. Reset User Codes/Counters	18

SETTING ORIGINALS IN THE DUAL JOB FEEDER

Recommended Originals	19
Non-recommended Originals	20
Setting A Stack Of Originals	21
Automatic Document Feed (ADF) mode (1 Sided Originals mode)	
Automatic Reverse Document Feed (ARDF) mode (2 Sided Originals mode)	
Setting One Original At A Time	23
Semi-Automatic Document Feed (SADF) mode	
Setting Different Sized Originals	25
Mixed Sized mode	
Setting A Pasted Original	27
Pasted Original mode	
Presetting Originals During A Copy Run	29

SETTING ORIGINALS IN THE RECIRCULATING DOCUMENT HANDLER

- Recommended Originals 31
- Non-recommended Originals 32
- Setting Originals 32

SETTING ORIGINALS ON THE EXPOSURE GLASS 34

BASIC FUNCTIONS AND KEY TOPS

- Sort 37
- Stack 38
- Stapling Copies 39
- Manual Staple 41
- Special Orig. 41
- Preset 41
- Program Key 42
- Interrupt Key 42
- Auto Start Mode 42

FUNCTIONS ON OPERATION SCREENS

- Reduce/Enlarge 43
- Duplex/Series Copies (Duplex) 44
- Duplex/Series Copies (Series Duplex) 48
- Duplex/Series Copies (Series Copies) 50
- Duplex/Series Copies (Combine) 52
- Edit Image(Editing/Centering) 56
- Edit Image (Margin Adj.) 59
- Cover/Slip Sheet (Front Cover) 60
- Cover/Slip Sheet (Front/Back) 61
- Cover/Slip Sheet (Paper Designate) 62
- Cover/Slip Sheet (OHP Slip Sheet) 63

LOADING PAPER 64

- 550-sheet Paper Tray 66
- Tandem Paper Tray 67
- 1,500-sheet Large Capacity Tray 69
- Optional 3,500-sheet Large Capacity Tray 70
- Bypass Feed Tray 71

CHANGING PAPER SIZE 73

WHAT TO DO WHEN THINGS GO WRONG 75

USER REMARKS 76

DO'S AND DON'TS 77

DAILY MAINTENANCE

- Copier 78
- Dual Job Feeder 79
- Recirculating Document Handler 80

TABLE OF CONTENTS

SPECIFICATIONS

Copier 81
Dual Job Feeder 85
Compact Sorter Stapler 86
Floor Type Sorter Stapler 87
Recirculating Document Handler 88
Finisher 89
3,500-sheet Large Capacity Tray 90

COMBINATION CHART 92

INDEX 94

**Before reading this Operating Instructions,
please refer to pages 2 ~ 5 to know which type
of copier and system you have.**

GUIDE TO COMPONENTS

Copier Type

There are two types of copier.

Type 1

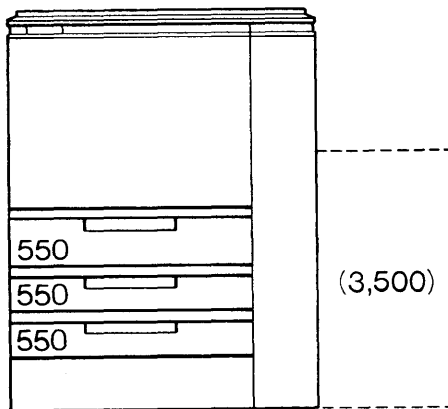

Three 550-sheet paper trays
Optional 3,500-sheet large capacity tray

Type 2

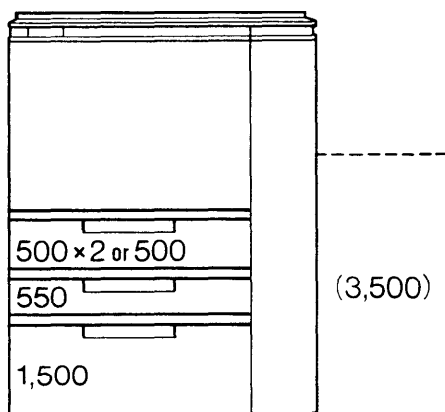

Tandem paper tray (two 500-sheet paper trays)
One 550-sheet paper tray
1,500-sheet large capacity tray
Optional 3,500-sheet large capacity tray

Copier Exterior

GUIDE TO COMPONENTS

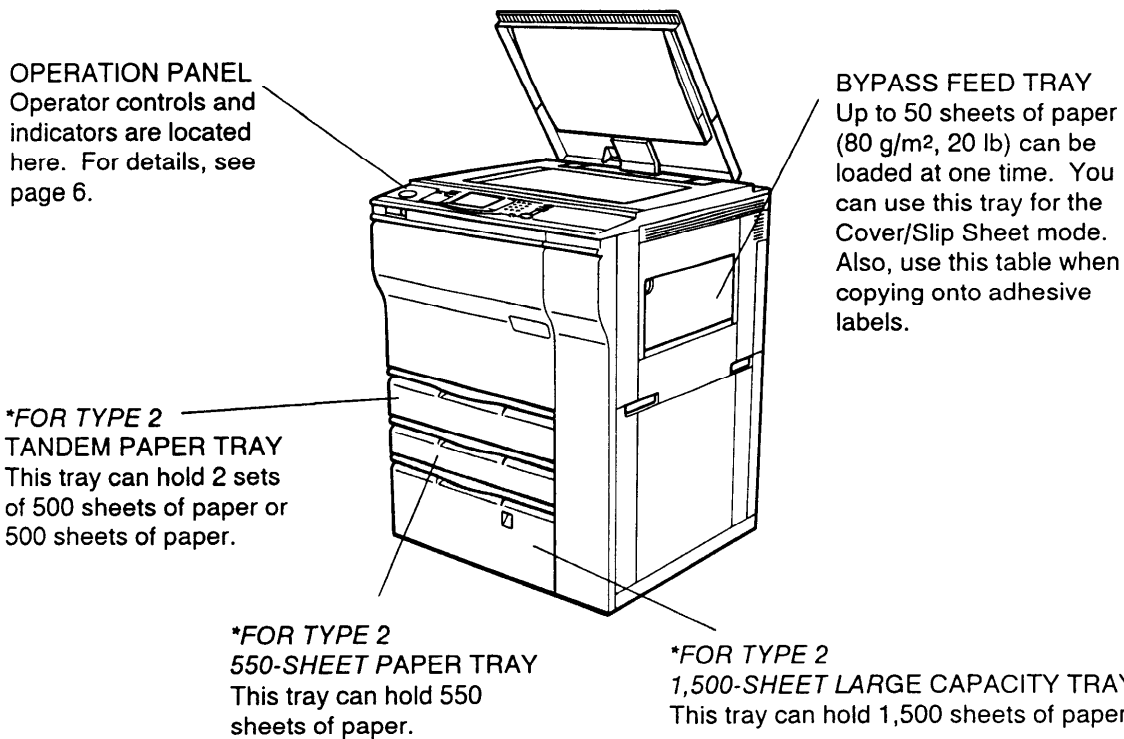
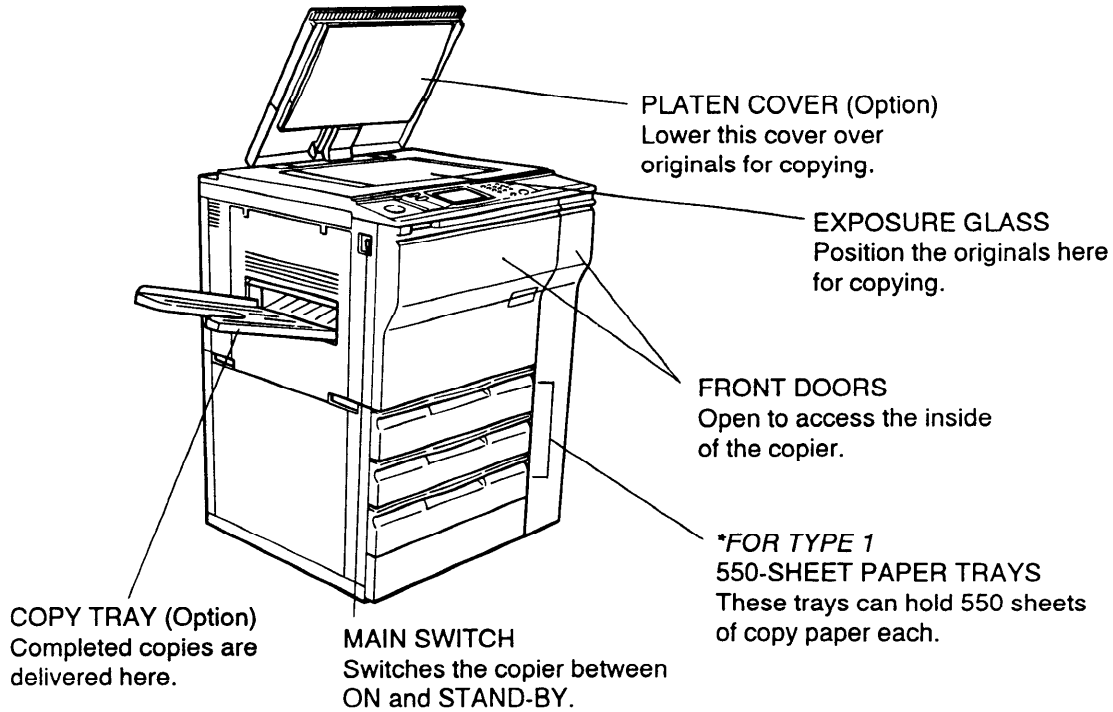

System Overview

System A

(Copier type 1 with dual job feeder and compact sorter stapler)

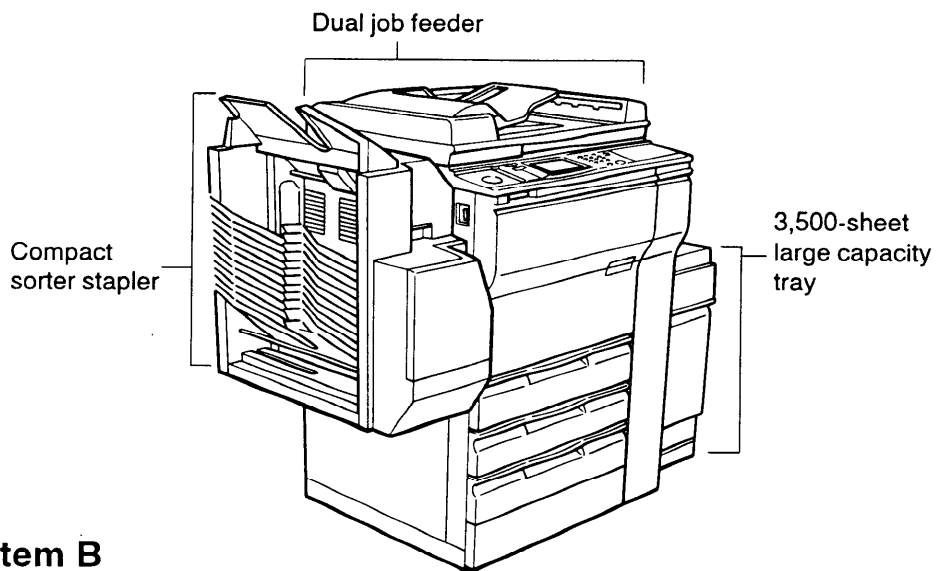

System B

(Copier type 1, or 2 with dual job feeder and floor type sorter stapler)

*Illustration shows type 2.

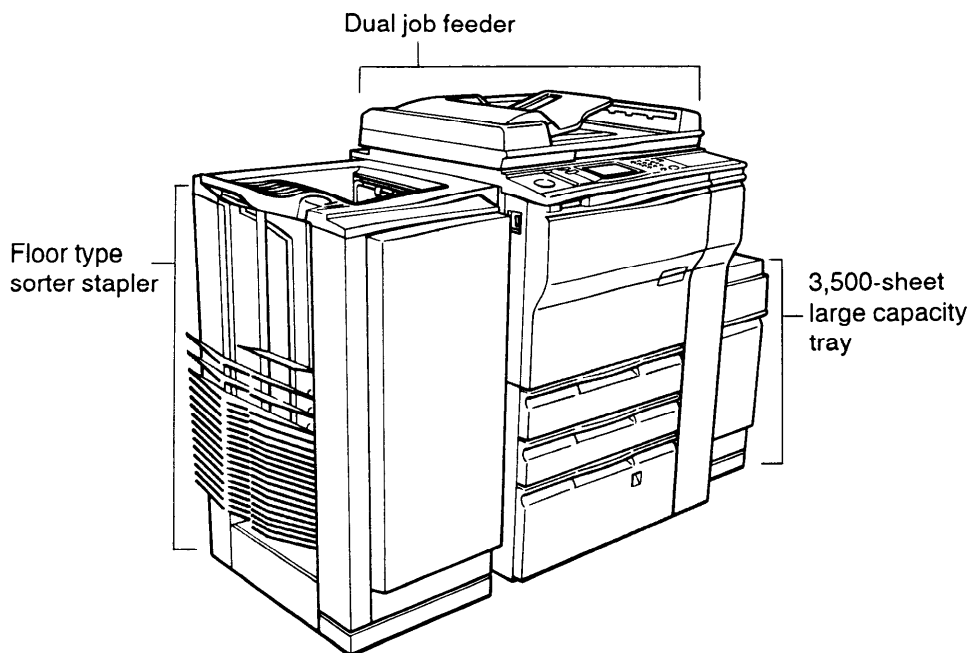

System C

(Copier type 2 with recirculating document handler and finisher)

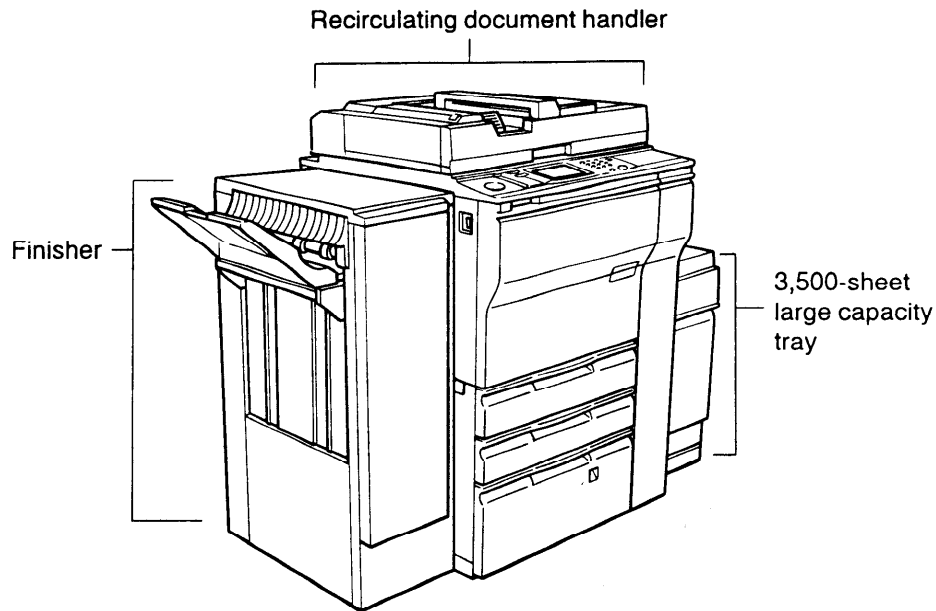

Operation Panel

Key Tops

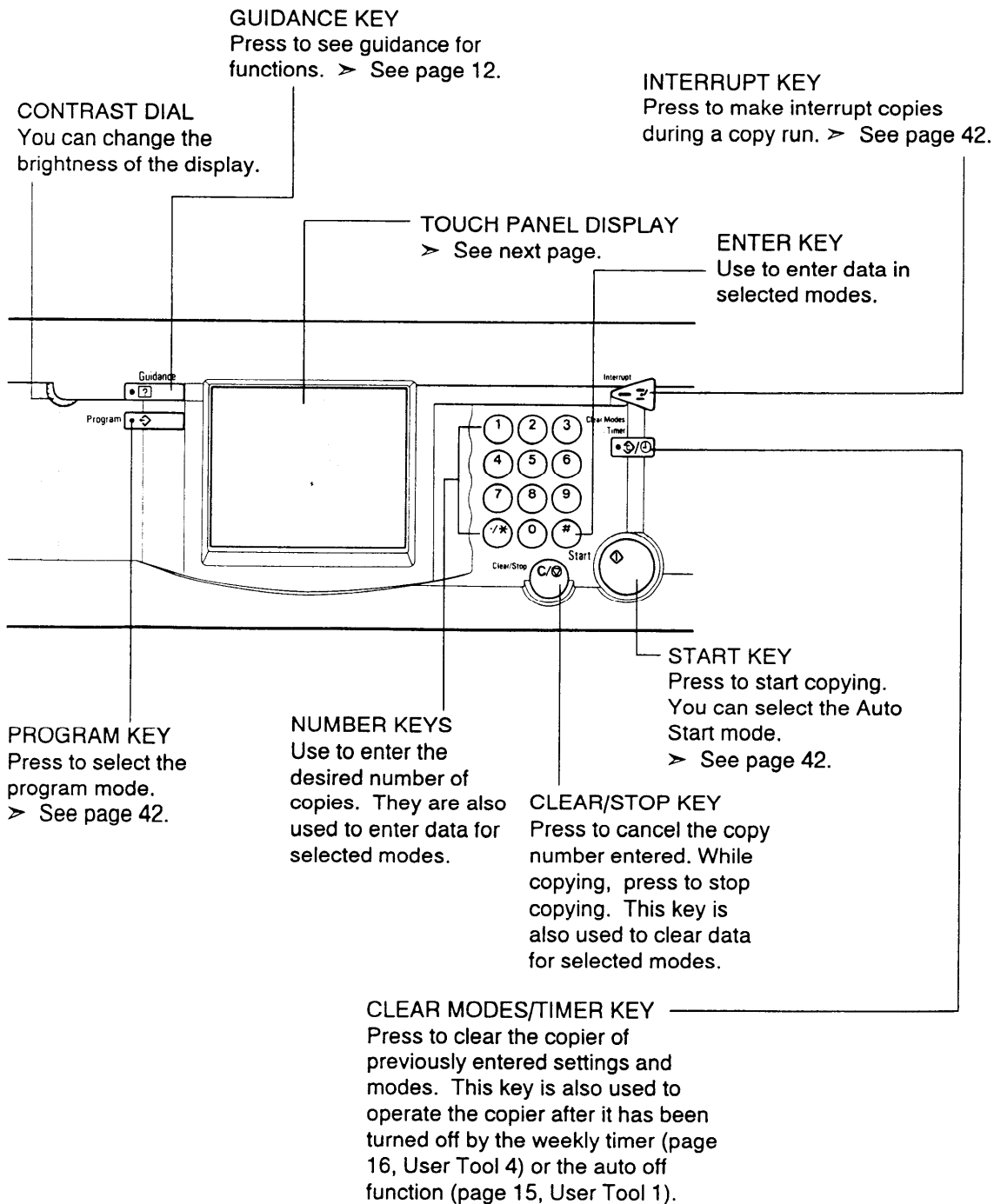

Touch Panel Display

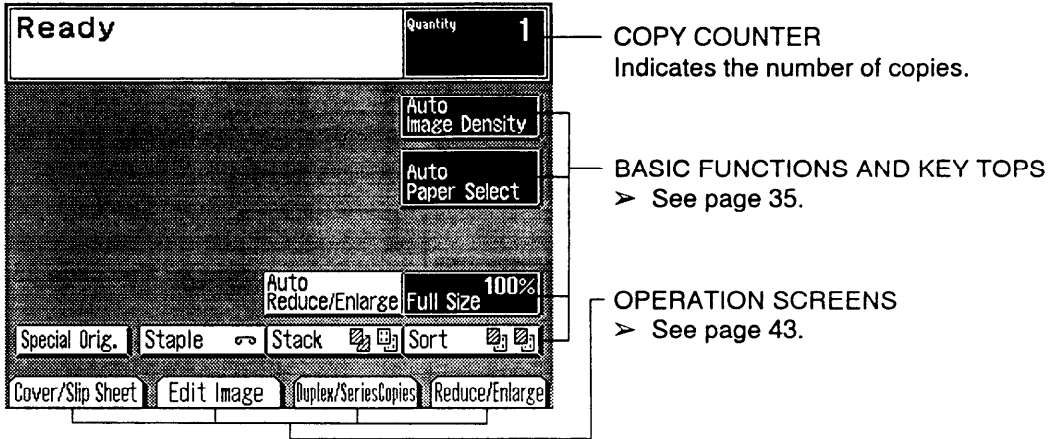

Initial Display

System A and B

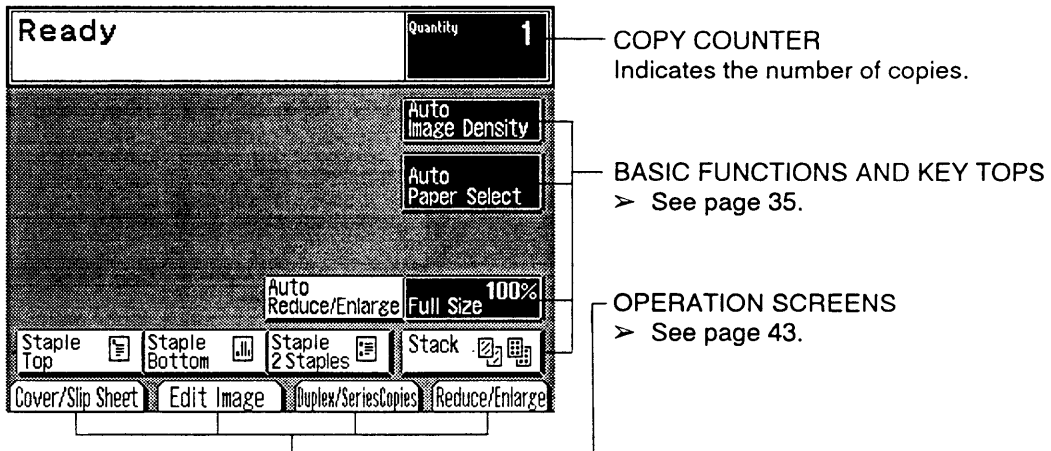

System C

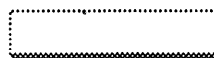

-  Keys that have the option of being selected.
-  Keys that have been selected.
-  Keys that have no option to select.

WHAT YOU CAN DO WITH THIS COPIER

System A and B

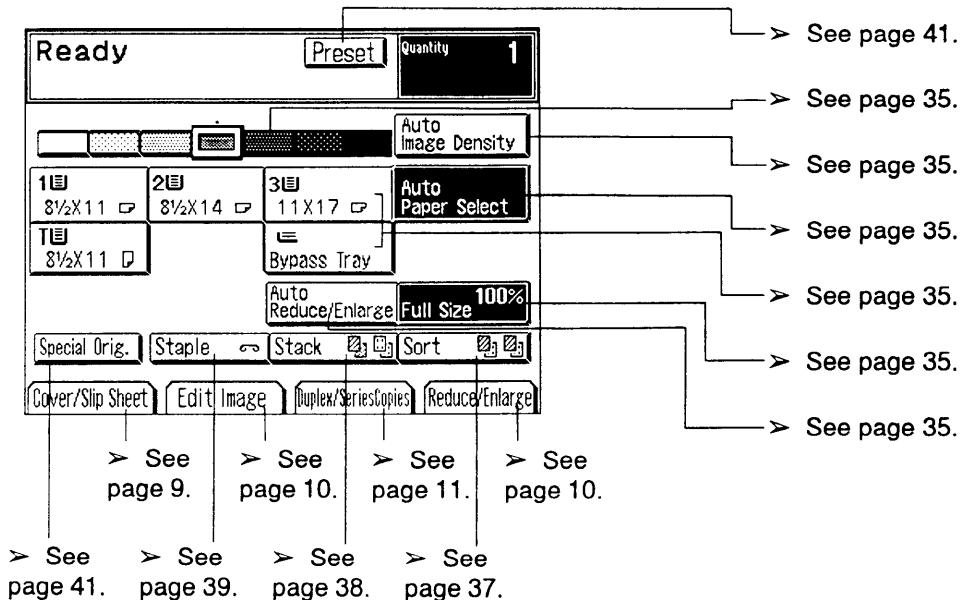

System C

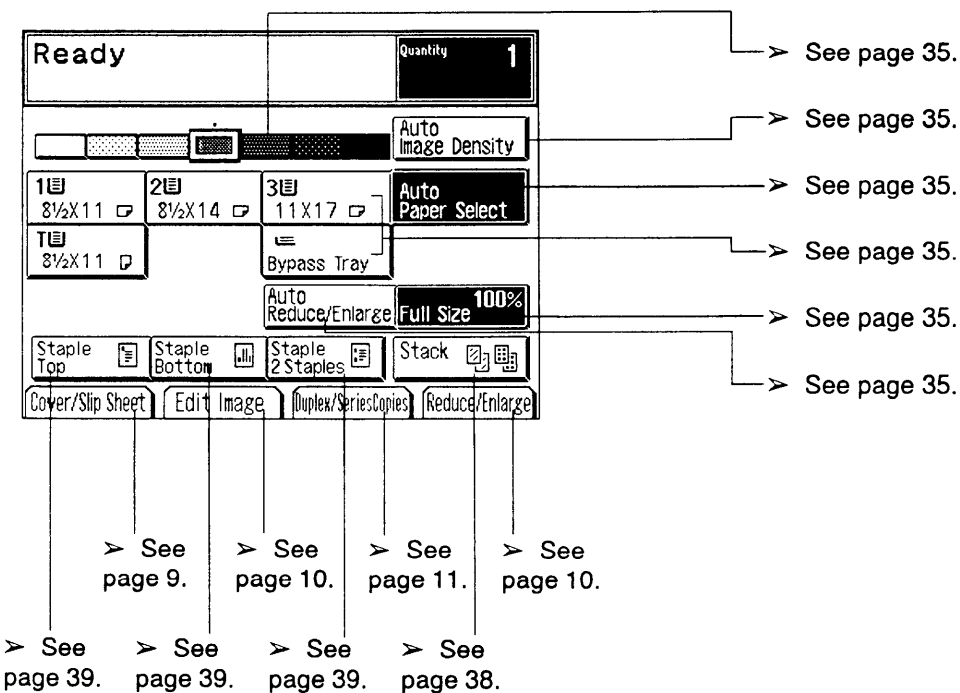

Cover/Slip Sheet

➤ See pages 60 ~ 63.

Front Cover

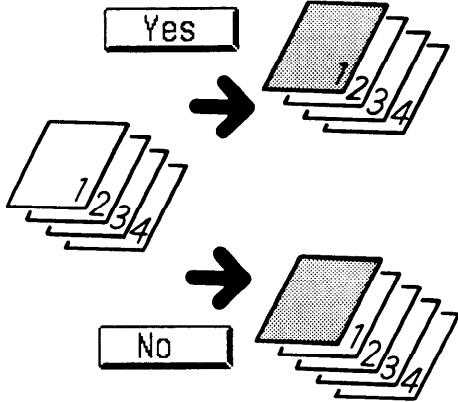

Paper Designate

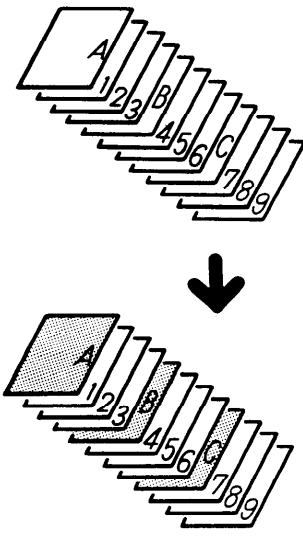

Front/Back

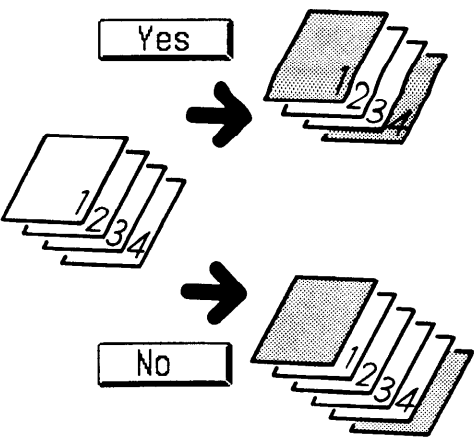

OHP Slip Sheet

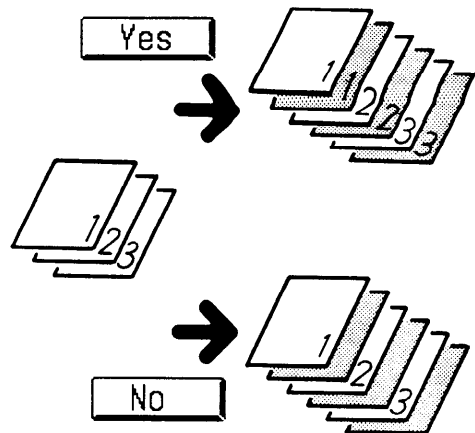

WHAT YOU CAN DO WITH THIS COPIER

Edit Image

> See pages 56 ~ 59.

Editing/Centering

Save Area **Erase Border**

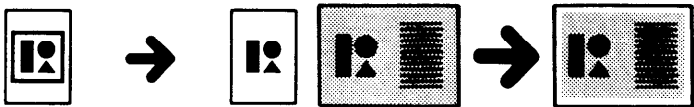

Delete Area **Cent. / Bord.**



Centering

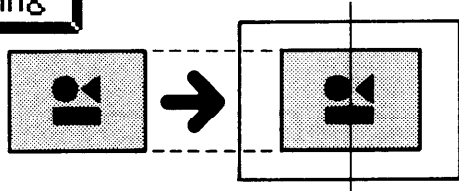

Margin Adj.

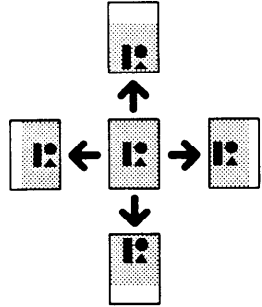

Reduce/Enlarge

> See page 43.

Preset R/E

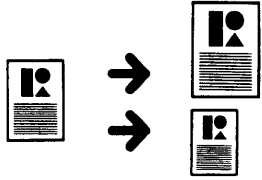

Zoom

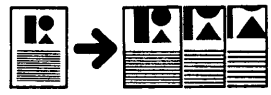

Size Mag.

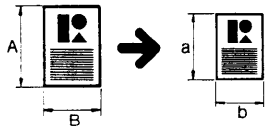

Duplex/SeriesCopies

> See pages 44 ~ 55.

Duplex

1Sided → 2Sided

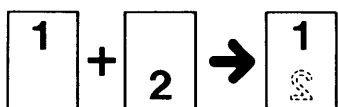

2Sided → 2Sided

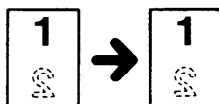

Series Duplex

Single

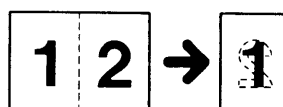

Multi

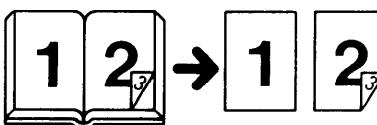

Series Copies

Book → 1Sided

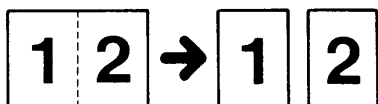

2Sided → 1Sided

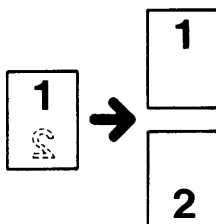

Combine

Combine 2 Origs.

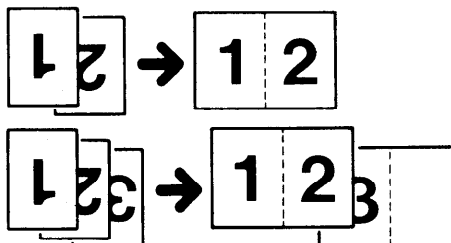

Combine 4 Origs.

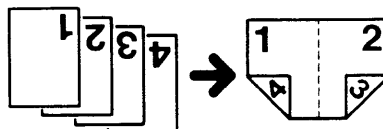

WHAT YOU CAN DO WITH THIS COPIER

HOW TO SEE THE GUIDANCE DISPLAY

Press the **Guidance** key when you want to know detailed information about functions you use. You can use this key in stand-by or when entering the settings for a copy job.

Seeking Guidance In Stand-by

1. Press the **Clear Modes** key and the **Guidance** key.

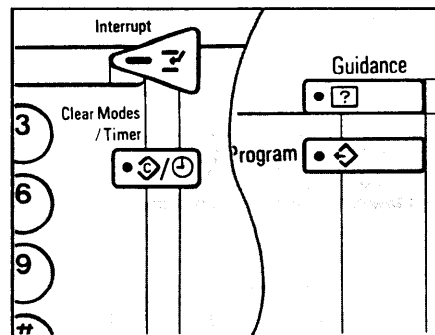

2. Touch the key you want to know about on the touch panel display.

- The touch panel display shown at right is for systems A and B.

3. For example, if you want to know about "Key Layout", touch the **Key Layout** key.

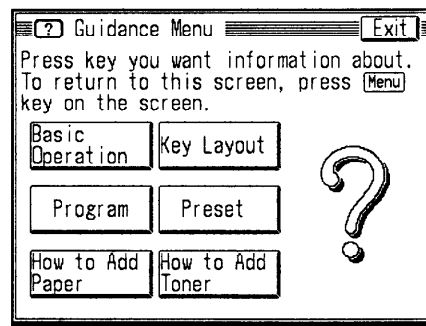

4. Touch the key you want to know about.

- If you want to return to the previous display, touch the **Menu** key.

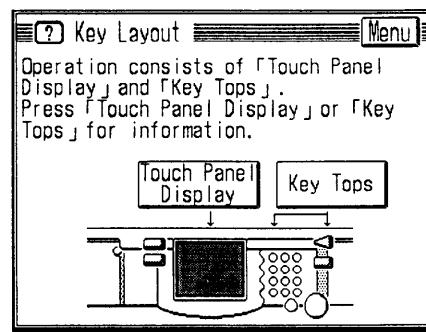

Seeking Guidance While Entering Job Settings

1. Press the **Guidance** key.

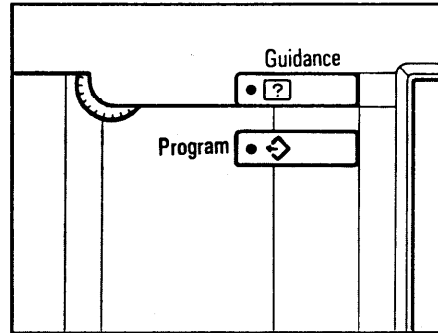

The information about functions you have selected just before will be displayed on the touch panel display. For example, if you have selected the Staple mode, the guidance appears as shown at right.

- The touch panel display shown at right is for system B.

2. To exit from the Guidance display, touch the **Exit** key.

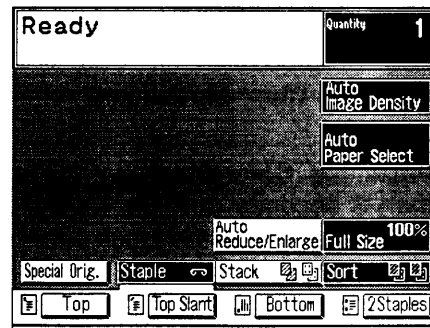
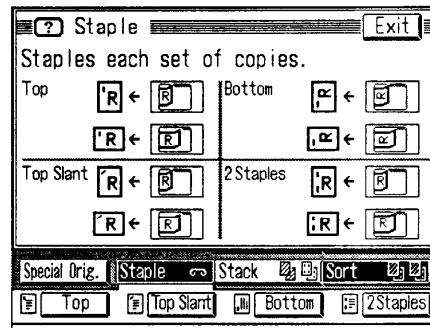

HOW TO SEE THE GUIDANCE DISPLAY

CHANGING DEFAULT SETTINGS

User Tools

This section is for the key operators in charge of this copier. You can change or set the copier's default settings using the following user tools.

User Tools Menu

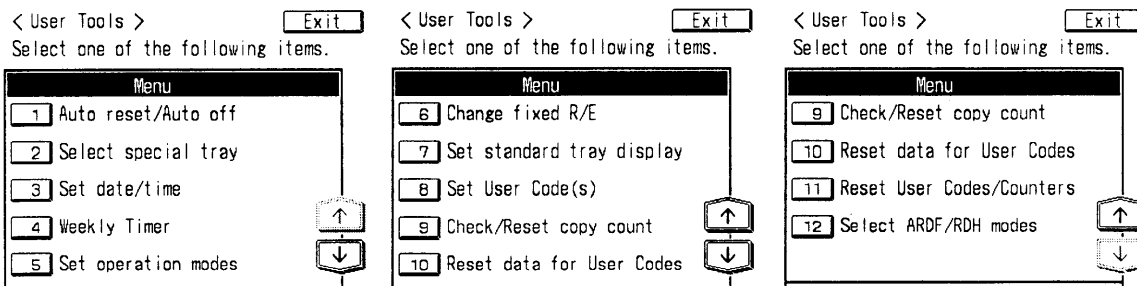

How To Access The User Tools

1. Press the **Clear Modes** key.
2. Press the **Clear/Stop** key for more than 3 seconds until the User Tools Menu appears on the touch panel display.
3. Select the menu number you want to use by touching the touch panel display.

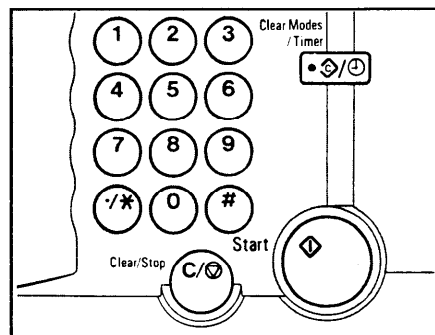

This copier has 12 user tools. You can see 5 user tools on the touch panel display at the same time. Use these keys to see other user tools menu.

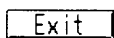

Use to exit from the user tool condition.



Use to return to the user tools menu display.

1 Auto reset/Auto off

Auto reset	The copier returns to its initial condition automatically after your job is finished. The automatic reset time can be set from 1 second to 999 seconds, or the function can be turned off. <input type="checkbox"/> default: 60 sec.
Screen Saver	When the machine does not detect anyone operating it for the selected time, the touch panel display turns off automatically. This time can be set from 1 second to 999 seconds, or the function can be turned off. <input type="checkbox"/> default: 60 sec.
Auto off	When the copier is used after the weekly timer has turned it off, the copier will turn itself back off after the selected time. The auto off time can be set from 1 minute to 999 minutes, or the function can be turned off. <input type="checkbox"/> default: OFF
SADF Auto reset (for machine with dual job feeder only) (system A or B)	In the SADF mode (Semi-Automatic Document Feed, see page 23), if the next original is not set within the selected time, the machine will cancel the SADF mode automatically. The SADF Auto reset time can be set from 1 second to 60 seconds, or the function can be turned off. <input type="checkbox"/> default: 5 sec.

2 Select special tray

Tray for Cover Sheet	Select the tray for the Cover function. Paper for cover sheets will be fed from the selected tray. <input type="checkbox"/> default: No select
Tray Display for Cover Sheet	You can see which tray is set for cover sheets. If you want to see the tray display only in the Cover mode, select "Mode selected". If you want to always see the tray display, select "Full time". <input type="checkbox"/> default: Full time
Tray for Slip Sheet	Select the tray for the Slip Sheet functions (Paper Designate and OHP Slip Sheet). Paper for slip sheets will be fed from the selected tray. <input type="checkbox"/> default: No select
Tray Display for Slip Sheet	You can see which tray is set for the slip sheets. If you want to see the tray display only in the Slip Sheet mode, select "Mode selected". If you want to always see the tray display, select "Full time". <input type="checkbox"/> default: Full time

- The trays set for cover sheets or slip sheets cannot be used for the Auto Paper Select, Auto Tray Switching, and Duplex copying modes.

3 Set date/time

Use to set the copier's internal clock before setting the weekly timer. Set the clock following the touch panel display instructions.

- If necessary, remember to adjust the clock for daylight saving time (summer time), or return it to standard time.

4 Weekly Timer

Use to set the weekly timer. If you set the timer, the copier turns on and off automatically at the selected time each day.

- default: No weekly timer setting
- If you want to turn on the machine for an entire day, input "000" for the ON time and do not input the OFF time.
- If you want to turn off the machine for an entire day (ex.: Saturday, Sunday), do not input the ON time and input "000" for the OFF time.

5 Set operation modes

Maximum copy input number	The maximum copy quantity can be set from 1 to 999. <input type="checkbox"/> default: 999
Panel beeper	The beeper (key tone) can be set to on or off. <input type="checkbox"/> default: ON
Job End Call	The beeper (job end call) sounds when your copying job is finished, supplies (toner, paper) run out, or if a problem occurs in the machine. The Job End Call can be set to on or off. <input type="checkbox"/> default: ON
<div style="display: flex; justify-content: space-between; align-items: center;"> Next ↓ ↑ Prev. </div>	
Image Density Level	Auto and Manual Image Density levels can be adjusted to lighter or darker. <input type="checkbox"/> default:  (center)
Default Setting	You can select Program No. 5 (see page 42) as a default mode. Use it to store job settings you frequently use. <input type="checkbox"/> default: Normal
Touch Panel in Waiting Mode	You can select the animation display during the warm-up period and copying run. During the warm-up period, the remaining warm-up time is displayed. During copying, you can see how long it takes to finish copying by entering the number of originals with the Number keys and Enter key. To exit from the animation display, touch the Exit key of the touch panel display. <input type="checkbox"/> default: Reset (no animation display)

6 Change fixed R/E

This copier has 10 fixed ratios (4 enlargements and 6 reductions). You can change these fixed reproduction ratios to different ratios.

7 Set standard tray display

Paper Tray Priority	When Auto Paper Select is canceled, the 1st tray is selected as a default setting. You can cancel this setting and select the other tray as a default setting. <input type="checkbox"/> default: OFF
Auto Paper Select Priority	As a default setting, the Auto Paper Select is selected. You can cancel this setting. <input type="checkbox"/> default: Yes
Paper Tray Display in APS mode	In the default setting, the tray display is shown only when the Auto Paper Select mode is canceled. You can cancel this setting and have the tray display shown always. <input type="checkbox"/> default: No
Auto Tray Switching	If you load paper of the same size and in the same direction in two or more paper trays, the machine automatically shifts to another tray when the tray in use runs out of paper. <input type="checkbox"/> default: Yes <input type="checkbox"/> Bypass feed tray, and trays for cover sheet and slip sheet cannot be used for Auto Tray Switching.

☞ Regarding User Tools No. 8, 9, 10, and 11, see the next page.

12 Select ARDF/RDH modes

This user tool can be used only when your machine is equipped with the dual job feeder (system A and B) or the recirculating document handler (system C).

Original Count Display	In the default setting, you can see the entered copy quantity on the upper part of the copy counter and the number of copies made on the lower part. You can cancel this setting and see the number of originals to be fed on the lower part of the copy counter. On the upper part, you can see the number of copies made. To cancel the default setting, select "Yes". <input type="checkbox"/> default: No
Auto Paper Select	In the default setting, the Auto Paper Select is not selected when you set originals in the dual job feeder or recirculating document handler. You can cancel this setting. <input type="checkbox"/> default: No
Thin Paper mode (for machine with dual job feeder only) (system A or B)	Use when changing the type of originals to be fed. Select this function when you use thin originals (lighter than 53 g/m ² , 14 lb). <input type="checkbox"/> default: No

User Tools for User Code Mode

If the copier is set to use the User Code function, operators must input their user codes before the machine can operate. The copier keeps count of the number of copies made under each user code. To have the machine set to the User Code mode, please contact your sales or service representative .

User tools 8, 9, 10 and 11 are for the User Code mode. When you want to use these user tools, you should enter the key operator access code first. Please ask your sales or service representative for the key operator access code when the machine is set to the User Code mode.

*If your machine is set to the User Code mode, to prevent others from making copies using your user code, while holding down the **Clear Modes** key, press the **Clear/Stop** key after copying.*

8 Set User Code(s)

Register	Use to register your user code (maximum: 6 digits) <input type="checkbox"/> Up to 500 user codes can be registered. <input type="checkbox"/> Registered user codes will be sorted in numerical order.
Change	Use to change your present code to a new one. <input type="checkbox"/> The number of copies made under the old code is added to that made under the new user code.
Delete	Use to delete your user code. <input type="checkbox"/> The number of copies made under the code is deleted.

9 Check/Reset copy count

You can check the number of copies made using each user code. Also, you can clear each code's counter.

10 Reset data for User Codes

Use to reset counter data for all user codes.

11 Reset User Codes/Counters

Use to reset all user codes and counters.

SETTING ORIGINALS IN THE DUAL JOB FEEDER

Recommended Originals

For this dual job feeder, the following types of originals can be used.

	Paper Weight	41 ~ 52 g/m ²	53 ~ 80	81 ~ 104	105 ~ 128
		11 ~ 13 lb	14 ~ 20	21 ~ 28	29 ~ 34
	Maximum number of originals to be set	50	50	30	25
A4/A3 version	A3 lengthwise	*	●	○	*
	A4 lengthwise	*	●	○	*
	A4 sideways	*	●	○	*
	A5 sideways	*	○	○	*
	B4 lengthwise	*	●	○	*
	B5 lengthwise	*	●	○	*
	B5 sideways	*	●	○	*
	F (8" x 13") lengthwise	*	●	○	*
LT/DLT version	11" x 17" lengthwise	*	●	○	*
	8 1/2" x 14" lengthwise	*	●	○	*
	8 1/2" x 11" lengthwise	*	●	○	*
	8 1/2" x 11" sideways	*	●	○	*
	5 1/2" x 8 1/2" lengthwise	*	○	○	*
	5 1/2" x 8 1/2" sideways	*	*	*	*
	8" x 13" (F) lengthwise	*	●	○	*
	8 1/2" x 13" (F4) lengthwise	*	●	○	*
	8" x 10 1/2" lengthwise	*	●	○	*
	8" x 10" lengthwise	*	●	○	*
	8" x 10" sideways	*	●	○	*
	10" x 14" lengthwise	*	●	○	*
	11" x 15" lengthwise	*	●	○	*

- : Mixed Original mode
Preset mode
ADF mode (1 sided originals mode)
ARDF mode (2 sided originals mode)
SADF mode
- : ADF mode, ARDF mode, SADF mode
- *: ADF mode, SADF mode

Non-recommended Originals

Caution: The following types of originals are not recommended for use with the dual job feeder. Please place them directly on the exposure glass.

- Originals thicker than 128 g/m², 34 lb
- Originals thinner than 41 g/m², 11 lb
- Paper with any kind of coating (such as carbon) on the back, or originals that are taped together
- Originals smaller than A5 sideways, 5 1/2" x 8 1/2"
- Originals larger than A3, 11" x 17"
- Folded, curled, creased, or damaged originals
- Mailing labels, or perforated originals
- Bound, stapled, or clipped originals
- OHP transparencies
- Thermal fax paper

Setting A Stack Of Originals

Automatic Document Feed (ADF) mode (1 Sided Originals mode)

Automatic Reverse Document Feed (ARDF) mode

(2 Sided Originals mode)

In this mode, the operator inserts a stack of originals of the same size into the original table. These originals are individually fed onto and removed from the exposure glass.

1. Correct any curl, fold, or crease in the originals before setting. Square the stack of originals.

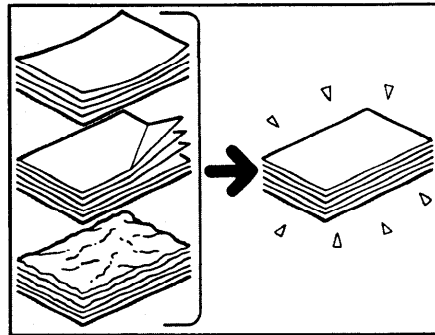

2. Confirm that the Insert Original indicator is lit before setting.
3. Confirm that no previous originals remain on the exposure glass.

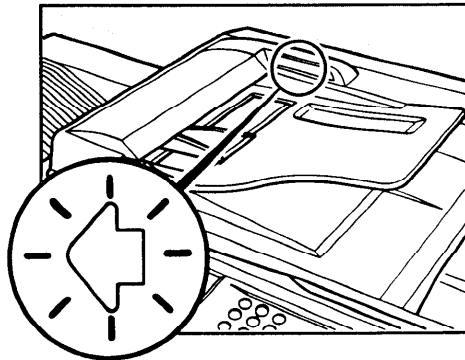

4. Adjust the original guide to the original size.

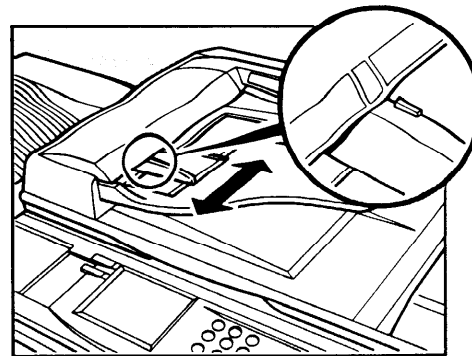

SETTING ORIGINALS IN
THE DUAL JOB FEEDER

5. Set originals *face up* into the dual job feeder until the **Insert Original** indicator goes off.

- The original guide must touch the front side of the originals.

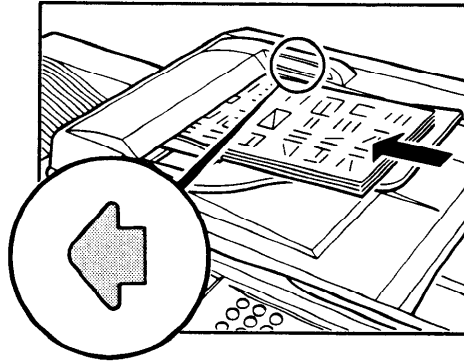

- Do not stack originals above the limit mark.

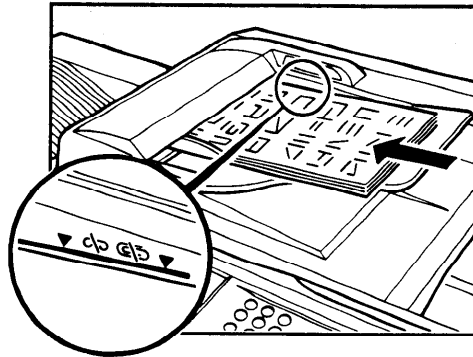

6. Press the **Start** key.

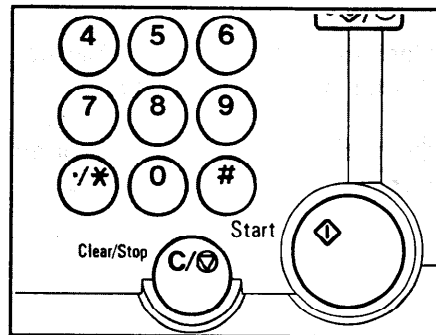

The bottom sheet of the original stack (last page) is fed into the dual job feeder first.

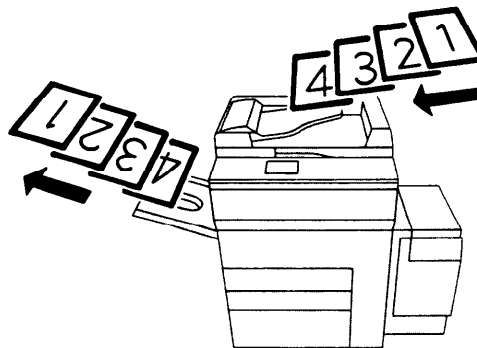

Setting One Original At A Time

Semi-Automatic Document Feed (SADF) mode

In this mode, the operator inserts one original at a time into the dual job feeder. The original is automatically fed onto and removed from the exposure glass.

1. Correct any curl, fold, or crease in the originals before setting.

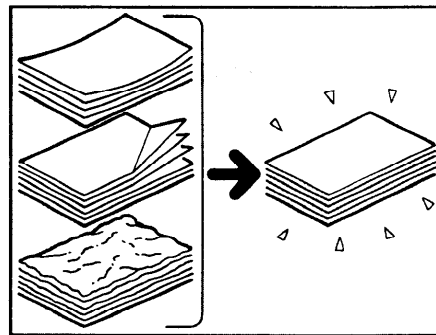

2. Confirm that the **Insert Original** indicator is lit before setting.
3. Confirm that no previous originals remain on the exposure glass.

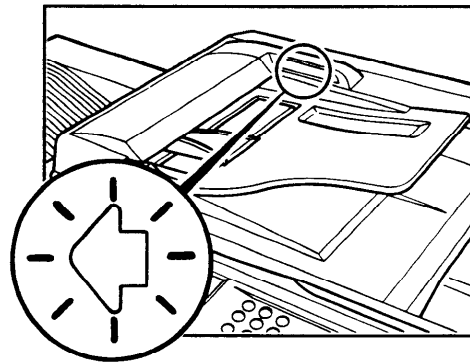

4. Adjust the original guide to the original size.

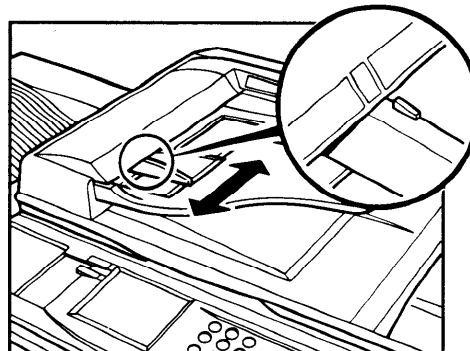

5. Set the original *face up* into the dual job feeder until the **Insert Original** indicator goes off.

- Start with the last page of the originals.
- The original guide must touch the front side of the original.

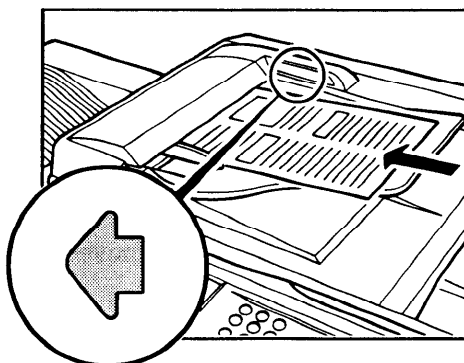

6. Press the **Start** key.

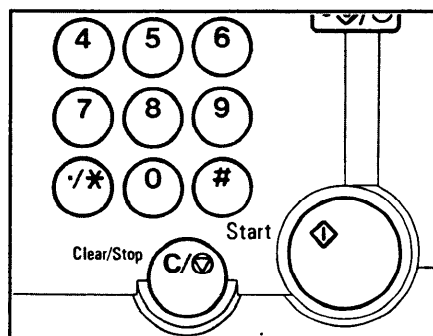

7. While the **Auto Feed** indicator is lit after an original is fed, set the next original. The original is automatically fed and copied.

- While the **Auto Feed** indicator is lit, the dual job feeder is ready for another original. (You can change this time by User Tool 1. See page 15.)

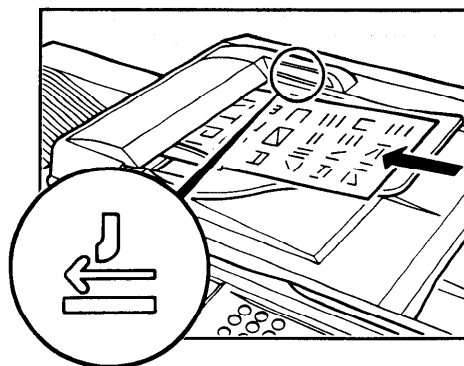

8. Repeat steps 5 and 7 until copying is completed.

Setting Different Sized Originals

Mixed Sized mode

In this mode, you can set originals with different widths and lengths together into the dual job feeder. You can use the following sizes:

A4/A3 version: A3, B4, A4 and B5
LT/DLT version: 11" x 17", 8 1/2" x 14", and 8 1/2" x 11"

1. Touch the **Special Orig.** key of the touch panel display. (See page 41.)
2. Touch the **Mixed Sizes** key of the touch panel display. (See page 41.)
3. Correct any curl, fold or crease in the originals before setting.

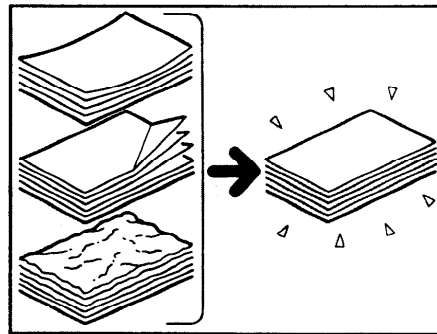

4. Confirm that the **Insert Original** indicator is lit before setting.
5. Confirm that no previous originals remain on the exposure glass.

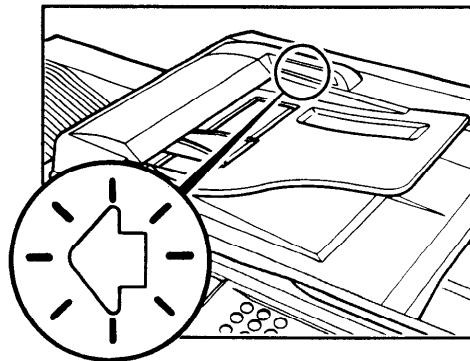

SETTING ORIGINALS IN
THE DUAL JOB FEEDER

6. Adjust the original guide to match the widest original.

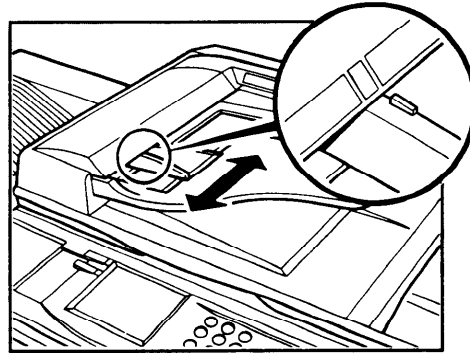

7. Set the originals *face up* into the dual job feeder until the Insert Original indicator goes off.

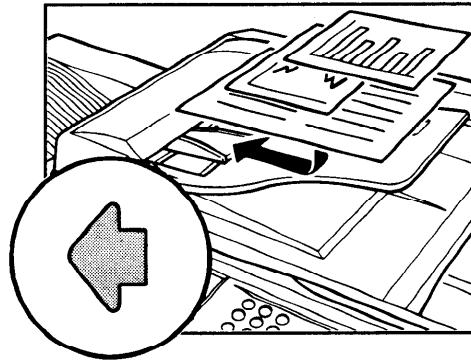

- Originals must be aligned to the rear-left corner of the dual job feeder, as shown.

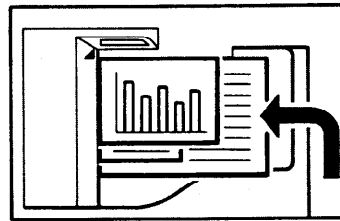

8. Press the **Start** key.

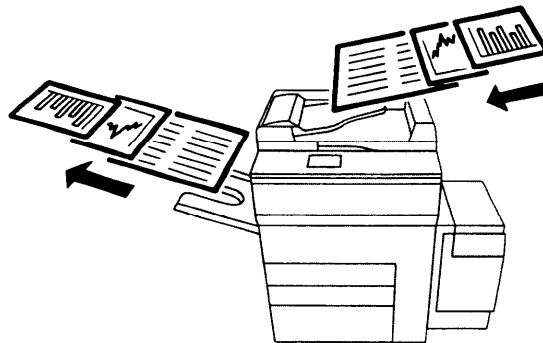

Setting A Pasted Original

Pasted Original mode

In this mode, you can set a pasted original into the dual job feeder.

□ In this mode, you can set one original at a time.

1. Touch the **Special Orig.** key of the touch panel display. (See page 41.)
2. Touch the **Pasted Original** key of the touch panel display. (See page 41.)
3. Correct any curl, fold or crease in the originals before setting.

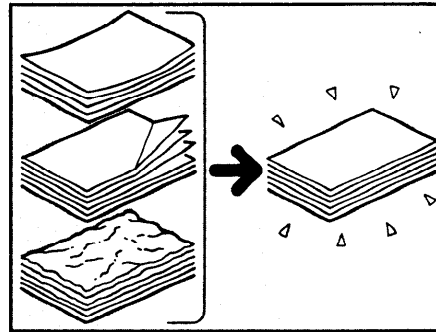

4. Confirm that the **Insert Original** indicator is lit before setting.
5. Confirm that no previous originals remain on the exposure glass.

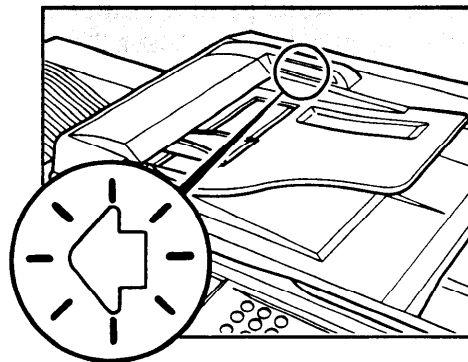

6. Adjust the original guide to the original size.

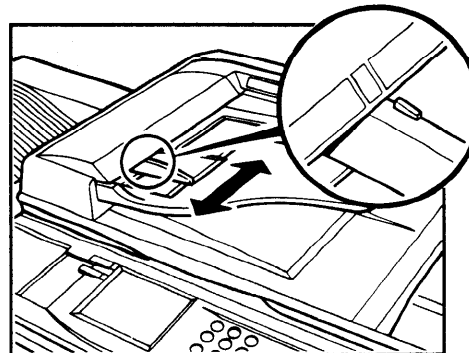

SETTING ORIGINALS IN
THE DUAL JOB FEEDER

7. Set one pasted original *face up* into the dual job feeder until the **Insert Original** indicator goes off.

- Start with the last page of originals.
- The original guide must touch the front side of the original.

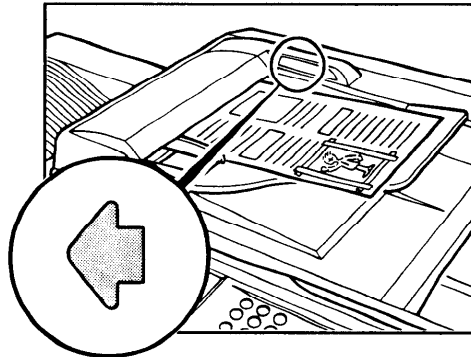

8. Press the **Start** key.

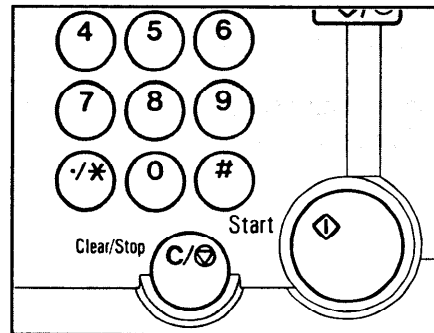

9. While the **Auto Feed** indicator is lit after an original is fed, set the next original. The original is automatically fed and copied.

- While the **Auto Feed** indicator is lit, the dual job feeder is ready for another original. (You can change this time by User Tool 1. See page 15.)

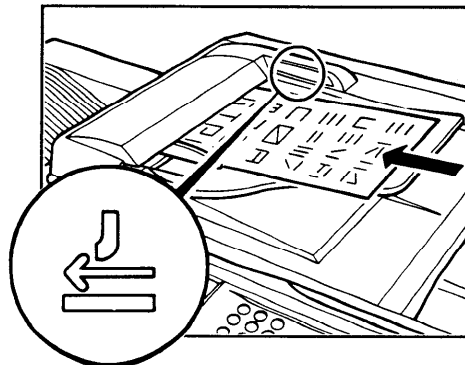

10. Repeat steps 7 and 9 until copying is completed.

Presetting Originals During A Copy Run

1. Touch the **Preset** key of the touch panel display. (See page 41.)

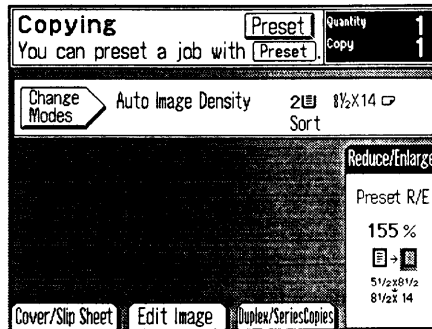

2. Following the instructions on the display, set the copy job settings for your next job.
3. Touch the **Exit** key of the touch panel display.

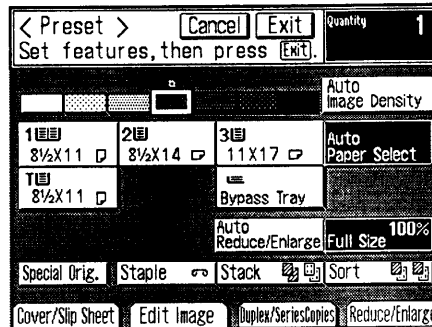

The touch panel display changes as shown.

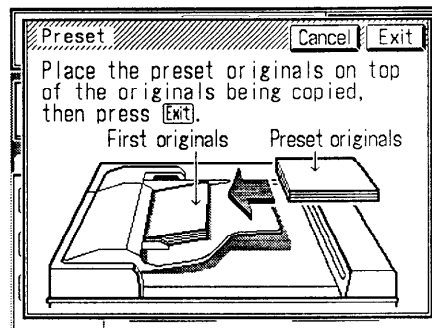

4. Set the originals for your next job on top of the originals being copied. Without forcing them, push them in completely.
 - Do not insert the originals too strongly.

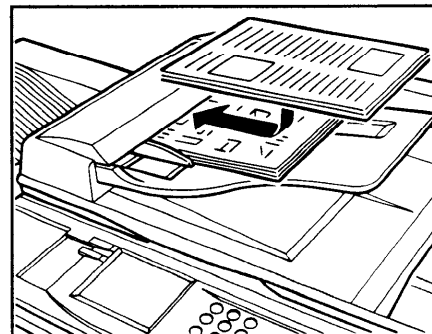

SETTING ORIGINALS IN THE DUAL JOB FEEDER

5. Touch the **Exit** key of the touch panel display.

After your first job is finished, the next job will start automatically.

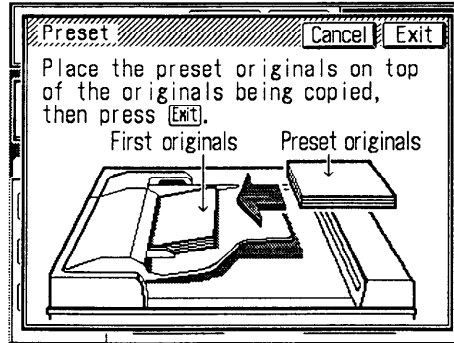

- When presetting a job using the compact sorter stapler, you have to remove the current job's copies from the sorter stapler before the preset job can start.
- When presetting a job using the floor type sorter stapler, you might have to remove the current job's copies before the preset job can start. You have to do this
 - when you make 11 or more copies in the current job.
 - when you make 10 copies in the current and 10 or more for the next.
 - when you make 9 or less copies for the current and 11 or more for the next.

SETTING ORIGINALS IN THE RECIRCULATING DOCUMENT HANDLER

SETTING ORIGINALS IN THE
RECIRCULATING
DOCUMENT HANDLER

Recommended Originals

For this recirculating document handler, the following types of originals can be used.

SIZE \ WEIGHT		52 ~ 103 (g/m ²)	104	105 ~ 128
		14 ~ 27 (lb)	28	29 ~ 34
A4/A3 version	A3 lengthwise	25 sheets	20 sheets	*20 sheets
	F (8" x 13") lengthwise			
	A4 sideways	50 sheets	40 sheets	*30 sheets
	A4 lengthwise			
A5 lengthwise	25 sheets	20 sheets	*20 sheets	
LT/DLT version				11" x 17" lengthwise
				8 1/2" x 14" lengthwise
				11" x 15" lengthwise
				10" x 14" lengthwise
				8 1/2" x 13" (F4) lengthwise
				8" x 13" (F) lengthwise
				8 1/2" x 11" sideways
	8 1/2" x 11" lengthwise			
5 1/2" x 8 1/2" lengthwise	50 sheets	40 sheets	*30 sheets	
8" x 10" lengthwise				

□ Translucent paper cannot be recirculated.

*These originals cannot be recirculated.

Non-recommended Originals

Caution: The following types of originals are not recommended for use with the recirculating document handler. Please place them directly on the exposure glass.

- Originals thicker than 128 g/m², 34 lb
- Originals thinner than 52 g/m², 14 lb
- Paper with any kind of coating (such as carbon) on the back, or originals that are taped together
- Originals smaller than A5 lengthwise, 5 1/2" x 8 1/2" lengthwise
- Originals larger than A3, 11" x 17"
- Folded, curled, creased, or damaged originals
- Mailing labels, perforated originals, or pasted originals
- Bound, stapled, or clipped originals
- OHP transparencies
- Thermal fax paper

Setting Originals

1. Correct any curl, fold, or crease in the originals before setting.
 - If you want to use originals of which you cannot correct the curl, fold, or crease, do the following:
 - First make one set of copies of originals, and use these copies as the recirculating originals. Limit the number of copies for one set of originals to 30.
2. Confirm that the **Set Original** indicator is lit. If it is not lit, confirm that the feed-out unit and feed-in unit covers are closed properly.
 - Make sure that no previous originals remain on the exposure glass or in the recirculating document handler.

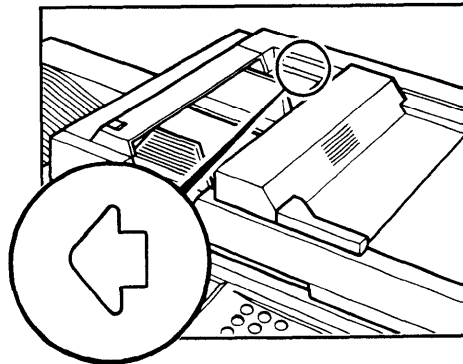
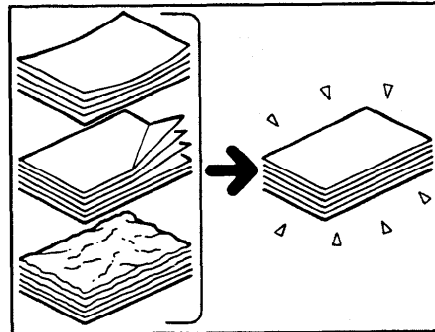

- Adjust the original guides to the original width.

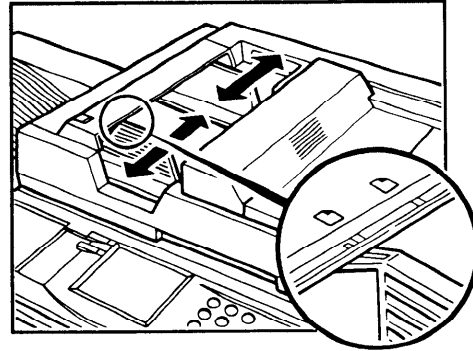

SETTING ORIGINALS IN THE
RECIRCULATING
DOCUMENT HANDLER

- If you have more than two originals, square the stack of originals. Set the originals *face up* in the original stacker. The **Set Original** indicator should turn off.

Originals should be the same size.

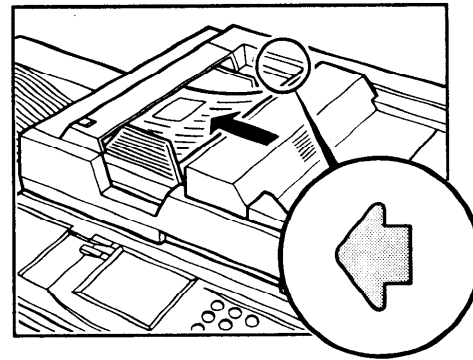

- Slide the feed-out unit to match the size marks on the front side of the recirculating document handler.

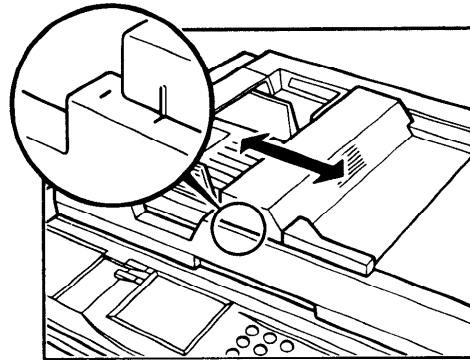

SETTING ORIGINALS ON THE EXPOSURE GLASS

THE EXPOSURE GLASS

If your machine is equipped with the platen cover

1. Lift the platen cover.
2. Set the original face down on the exposure glass. The original must be aligned to the rear left corner.
 - Before pressing the **Start** key, lower the platen cover.

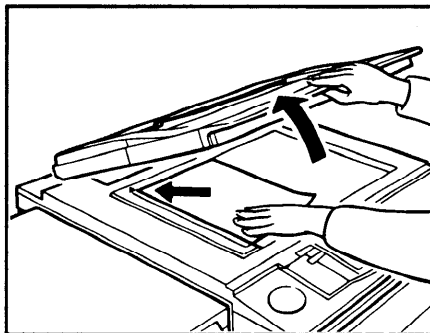

If your machine is equipped with the dual job feeder

1. Lift the dual job feeder.
2. Set the original face down on the exposure glass. The original must be aligned to the rear left corner.
 - Before pressing the **Start** key, lower the dual job feeder.

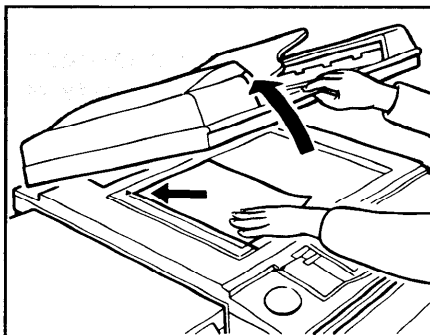

If your machine is equipped with the recirculating document handler

1. Lift the recirculating document handler.
2. Set the original face down on the exposure glass. The original must be aligned to the rear left corner.
 - Before pressing the **Start** key, lower the recirculating document handler.

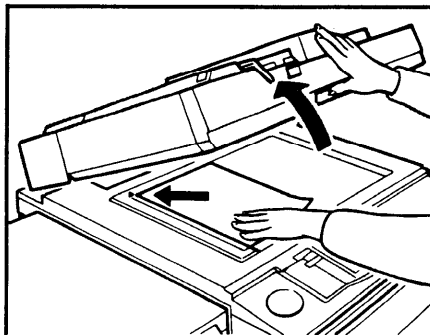

BASIC FUNCTIONS AND KEY TOPS



The copier automatically controls the image density according to the original background density.



After canceling the Auto Image Density, use these keys to adjust the image density manually. To get a darker image, touch the right keys. To get a lighter image, touch the left keys.



The copier selects a suitable size of copy paper based on the original size and the reproduction ratio.

- If you use translucent or transparent paper as an original, the original size might not be detected correctly.
- When you use Auto Paper Select when placing the original directly on the exposure glass, make sure that the platen cover, dual job feeder, or recirculating document handler is lowered before pressing the Start key. If not, the original size might not be detected correctly.

1 8½X11	2 8½X14	3 11X17
T 8½X11		Bypass Tray

After canceling Auto Paper Select, select the paper tray you want to use.



Use to make the copy image the same size as the original image.



The copier automatically selects the proper reproduction ratio suitable for the selected paper. All originals are copied onto the same selected paper size.

- If you use translucent or transparent paper as an original, the original size might not be detected correctly.
- When you use the Auto Reduce/Enlarge when placing the original directly on the exposure glass, make sure that the platen cover, dual job feeder, or recirculating document handler is lowered before pressing the Start key. If not, the original size might not be detected correctly.

BASIC FUNCTIONS AND KEY TOPS



When you have selected functions on operation screens, this key appears on the touch panel display. Touch this key to see at a glance all the modes you selected.

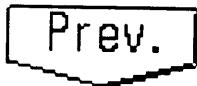

After the Check Modes key is touched, this key appears on the touch panel display. Touch this key to return to the display when the Check Modes key was touched.



When you select functions on the operation screens, this key appears on the touch panel display. Touch this key to change settings of the following modes.

- Copy paper size
- Image density control
- Finishing (Sort, Stack, and Staple)
- Special original setting (system A and B only)



Before using the Sort function, please refer to page 4 and 5 to know which system you have because this function is different depending on the system you have.

System A and B

One copy of each original is delivered to each bin and copies are collated into sets.

System C

System C does not have the Sort key. As a default setting, copies are assembled as sets in sequential order by sliding the shift tray from side to side.

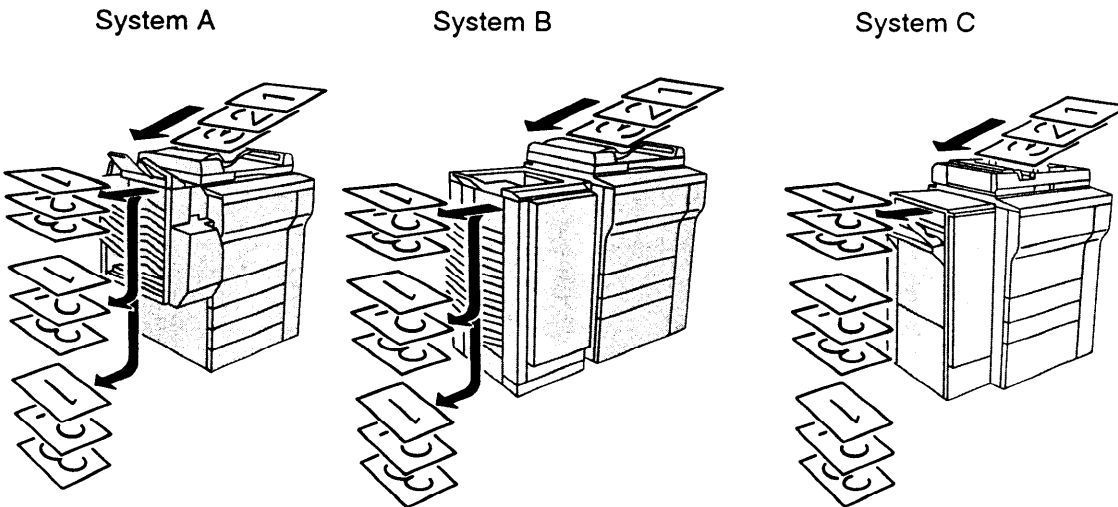

BASIC FUNCTIONS AND
KEY TOPS

□ For the Sort function, the following limitations apply:

	System A	System B	System C
Maximum paper size	A3, 11" x 17"	A3, 11" x 17"	A3, 11" x 17"
Minimum paper size	A5 lengthwise 5 1/2" x 8 1/2" lengthwise	Sideways: A4, 8 1/2" x 11" Lengthwise: A5, 5 1/2" x 8 1/2"	A5, 5 1/2" x 8 1/2"
Maximum paper weight	93 g/m ² , 25 lb	157 g/m ² , 42 lb	157 g/m ² , 42 lb
Minimum paper weight	52 g/m ² , 14 lb	52 g/m ² , 14 lb	52 g/m ² , 14 lb
Maximum capacity	A4, 8 1/2" x 11" or smaller: 30 sheets/bin B4, 8 1/2" x 14" or larger: 15 sheets/bin	all sizes: 50 sheets/bin 2 sided copies: 40 sheets/bin	A4, 8 1/2" x 11" or smaller: 1,500 sheets B4, 8 1/2" x 14" or larger: 1,000 sheets
Paper that cannot be used	Post cards, tracing paper, OHP sheets, and adhesive labels		



Before using the Stack function, please refer to page 4 and 5 to know which system you have because this function is different depending on the system you have.

System A and B

All copies of each original are delivered to the same bin.

System C

Copies from different copy runs are grouped into individual stacks by sliding the shift tray from side to side.

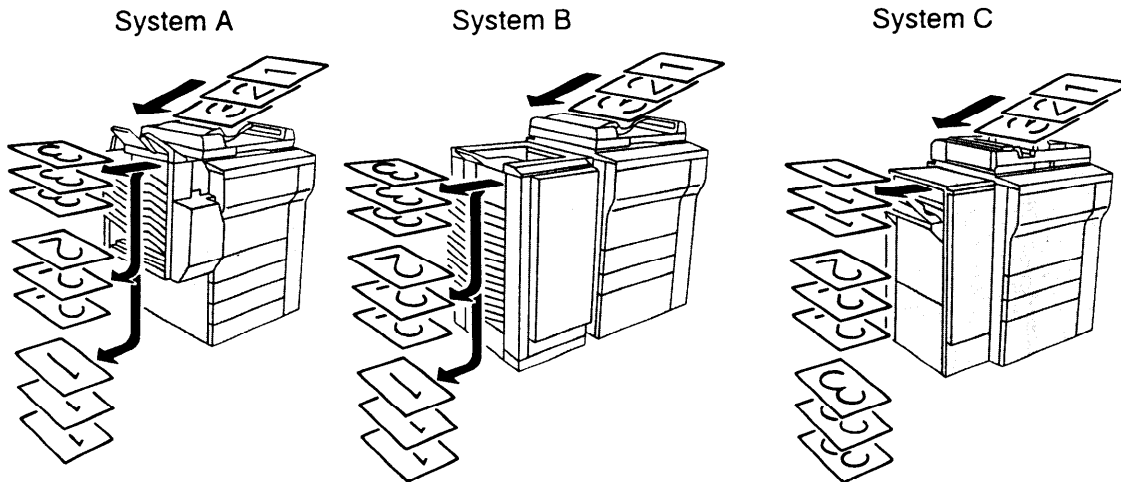

□ For the Stack function, the following limitations apply:

	System A	System B	System C
Maximum paper size	A3, 11" x 17"	A3, 11" x 17"	A3, 11" x 17"
Minimum paper size	A5 lengthwise 5 1/2" x 8 1/2" lengthwise	Sideways: A4, 8 1/2" x 11" Lengthwise: A5, 5 1/2" x 8 1/2"	A5, 5 1/2" x 8 1/2"
Maximum paper weight	93 g/m ² , 25 lb	157 g/m ² , 42 lb	157 g/m ² , 42 lb
Minimum paper weight	52 g/m ² , 14 lb	52 g/m ² , 14 lb	52 g/m ² , 14 lb
Maximum capacity	all sizes: 15 sheets/bin	all sizes: 40 sheets/bin 2 sided copies: 35 sheets/bin	A4, 8 1/2" x 11" or smaller: 1,500 sheets B4, 8 1/2" x 14" or larger: 1,000 sheets
Paper that cannot be used	Post cards, tracing paper, OHP sheets, and adhesive labels		

□ When using A3, 11" x 17" paper with system A, it might happen that the compact sorter stapler does not stack 15 sheets depending on the paper brand and condition.







Stapling Copies

Before using the Staple function, please refer to page 4 and 5 to know which system you have because this function is different depending on the system you have.

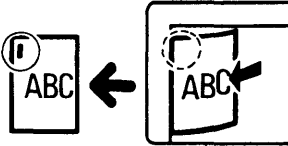
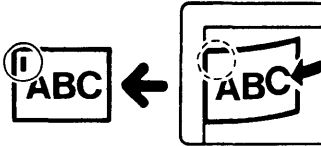
In the Staple function, groups of copies are automatically stapled.

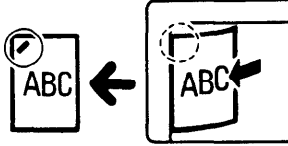
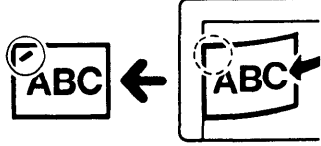
If you select this function, the Sort function is automatically selected.

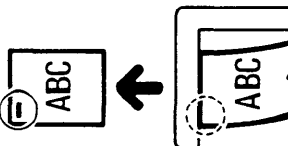
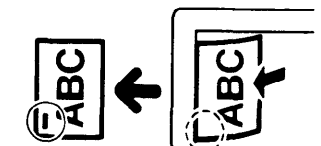
Stapling Position and Original Setting

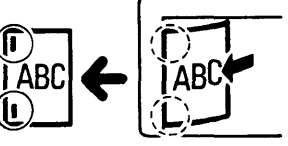
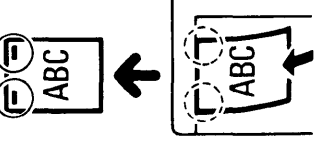
	System A	System B Staple ↺	System C
	Staple ↺	Top	Staple Top
			
	Not available	Top Slant	Not available
			
	Not available	Bottom	Staple Bottom
			
	Not available	2Staples	Staple 2Staples
			

BASIC FUNCTIONS AND KEY TOPS

For the Staple function, the following limitations apply:

	System A	System B	System C
Maximum paper size	A3, 11" x 17"	A3, 11" x 17"	A3, 11" x 17"
Minimum paper size	B5, 8 1/2" x 11"	B5, 8 1/2" x 11"	B5, 8 1/2" x 11"
Maximum paper weight	80 g/m ² , 20 lb	80 g/m ² , 20 lb	80 g/m ² , 20 lb
Minimum paper weight	52 g/m ² , 14 lb	64 g/m ² , 17 lb	64 g/m ² , 17 lb
Stapler capacity	A4, 8 1/2" x 11" or smaller: from 2 to 20 sheets B4, 8 1/2" x 14" or larger: from 2 to 10 sheets	all sizes: from 2 to 50 sheets	A4, 8 1/2" x 11" or smaller: from 2 to 50 sheets B4, 8 1/2" x 14" or larger: from 2 to 30 sheets
Paper that cannot be used	Post cards, tracing paper, OHP sheets, and adhesive labels		

In the Staple mode, do not use paper that is curled or has low stiffness.



This key can be used only when you have system A or B.

You can staple copies sorted in bins after copying is finished.



(This key has two functions. See below.)

This key can be used only when your machine is equipped with the dual job feeder (system A or B).

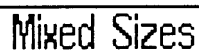

Use this key when you want to set the different sized originals together in the dual job feeder. The machine automatically detects the size of each original to be fed. You can set the following original sizes together. > See page 25.

A4/A3 version: A3, B4, A4 and B5

LT/DLT version: 11" x 17", 8 1/2" x 14", and 8 1/2" x 11"

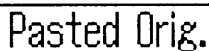

Use this key when you want to copy pasted originals using the dual job feeder. > See page 27.

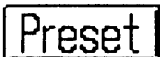

This key can be used only when your machine is equipped with the dual job feeder (system A or B).

You can set the copy settings for your next job. The next job will start automatically after the current job is completed. > See page 29.

- When presetting a job using the compact sorter stapler, you have to remove the current job's copies from the sorter stapler before the preset job can start.
- When presetting a job using the floor type sorter stapler, you might have to remove the current job's copies before the preset job can start. You have to do this
 - when you make 11 or more copies in the current job.
 - when you make 10 copies in the current and 10 or more for the next.
 - when you make 9 or less copies for the current and 11 or more for the next.

Program

You can store up to 5 frequently used copy job settings in machine memory, and recall them for future use.

□ You can select the Program No.5 as a default setting using the User Tool 5. See page 16.

Entering a program

1. Set the copy settings you want to put into memory.
2. Press the **Program** key.
3. Follow the instructions on the touch panel display.

Recalling a program

1. Press the **Program** key.
2. Follow the instructions on the touch panel display.

Interrupt

Press to interrupt a multicopy run to make urgently needed copies. The interrupted copy job settings are stored in the machine's memory. After interrupt copying is completed, press this key again to recall the previous copy job settings.

Auto Start Mode

When you press the **Start** key during warm-up, copying will start automatically after warm-up is completed. The **Start** key blinks in red and green alternately in this mode.

FUNCTIONS ON OPERATION SCREENS

Reduce/Enlarge

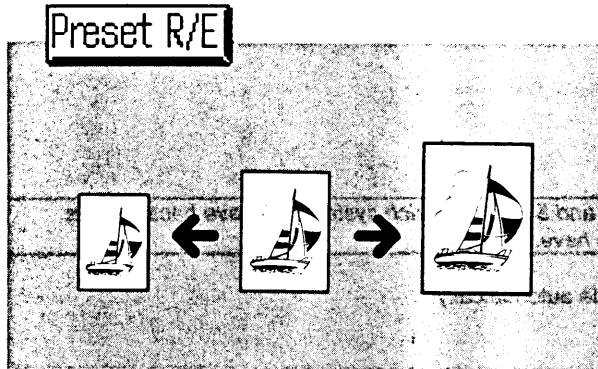

You can select one of 10 preset ratios. 6 reduction ratios and 4 enlargement ratios are preset.

- You can change the fixed ratios using User Tool 6. See page 17.

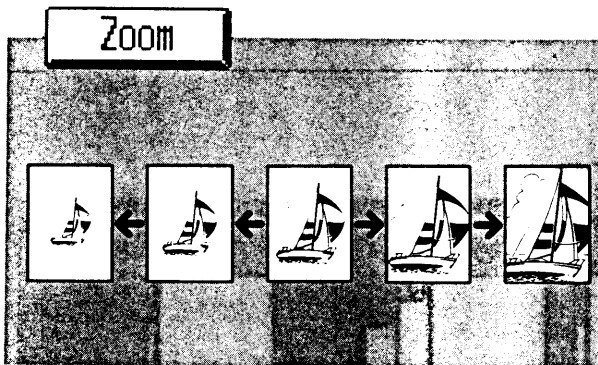

The reproduction ratio can be changed from 50% to 200% in 1% steps. There are two ways to change ratios.

default

Number Keys

Input the desired ratio using the Number keys.

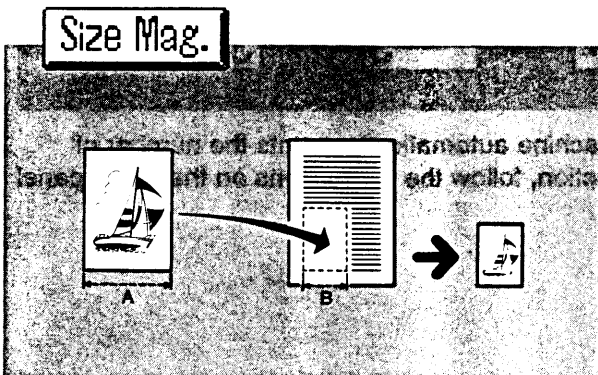

The suitable reproduction ratio will be automatically selected when you enter the lengths of the original (A) and the copy image you want (B).

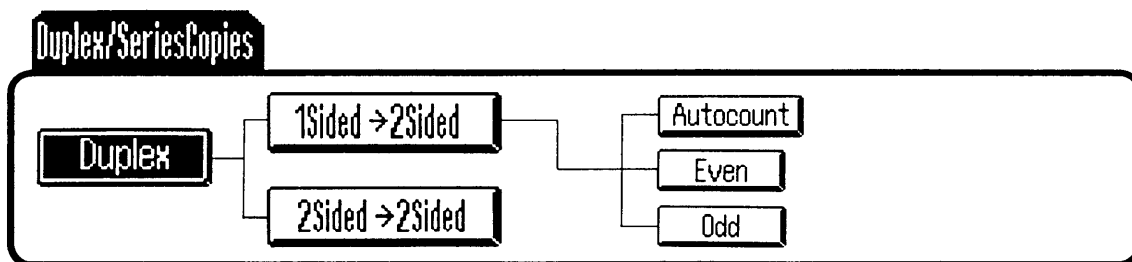

Duplex

1Sided → 2Sided

Before using this function, please refer to page 4 and 5 to know which system you have because this function is different depending on the system you have.

- A right margin (5 mm, 0.2") is set on the back side automatically.

System A and B

If your machine is equipped with the dual job feeder (system A or B), you should select one of three keys (Autocount, Even, or Odd)

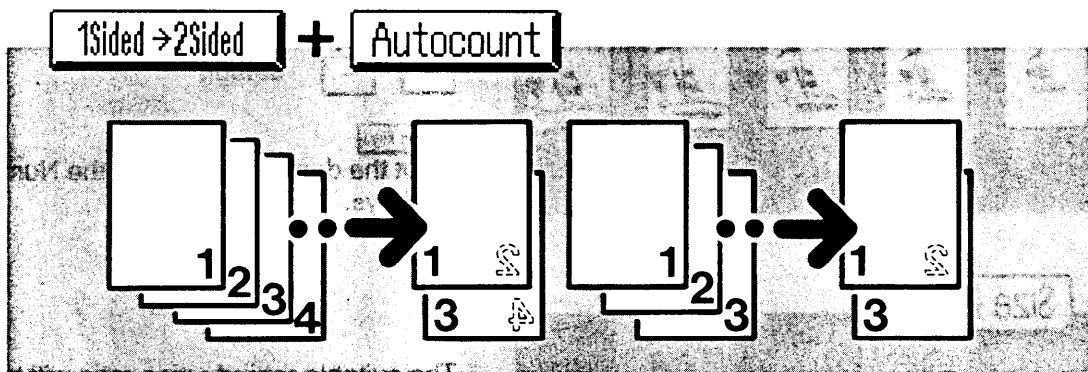

If you select the Autocount function, the machine automatically counts the number of originals. After selecting the Autocount function, follow the instructions on the touch panel display.

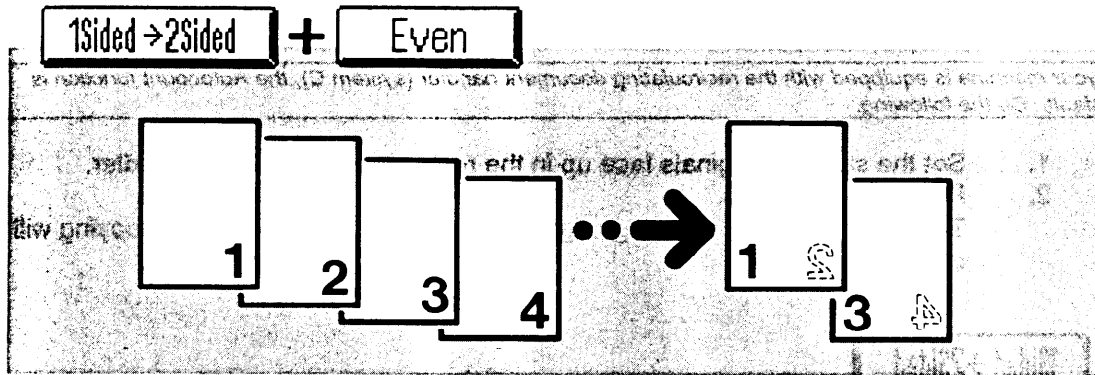

Select this key if the number of originals is even.

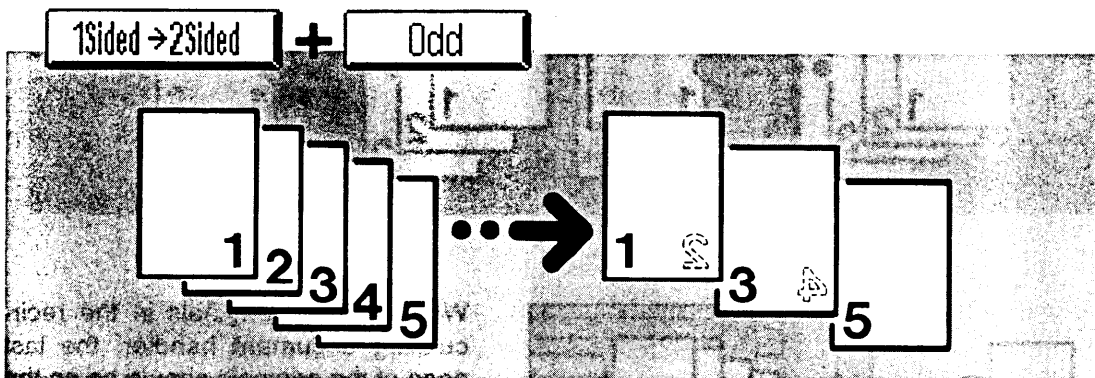

Select this key if the number of originals is odd.

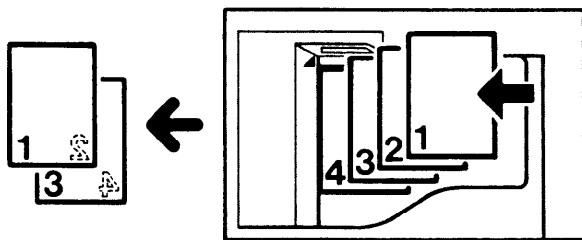

When you set originals in the dual job feeder, the last page of originals should be on the bottom as shown.

FUNCTIONS ON OPERATION SCREENS

System C

If your machine is equipped with the recirculating document handler (system C), the Autocount function is default. Do the following.

1. Set the stack of originals face up in the recirculating document handler.
2. Press the **Start** key.
The machine starts counting originals. After counting is finished, copying will start automatically.

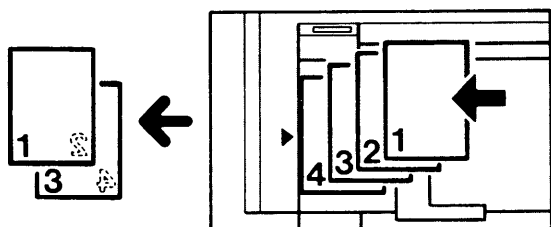
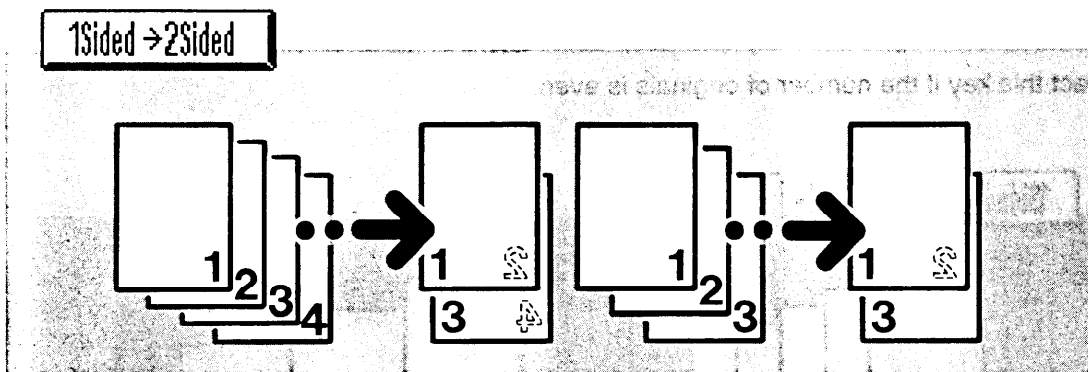

When you set originals in the recirculating document handler, the last page of the originals should be on the bottom as shown.

Duplex

2Sided → 2Sided

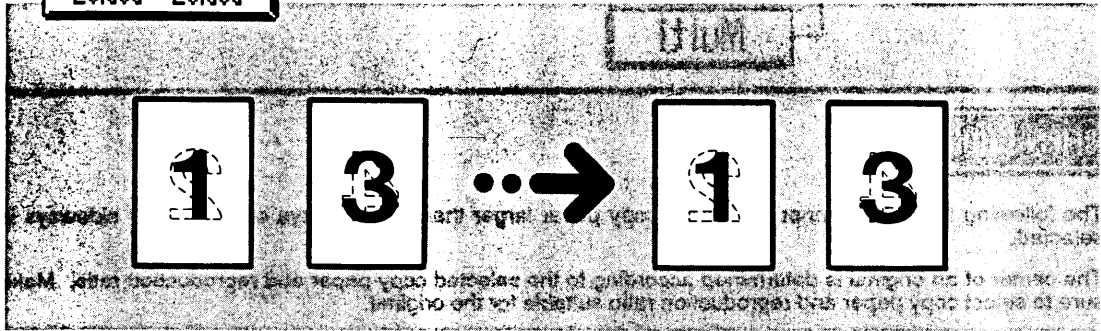

This function makes 2 sided copies from 2 sided originals.

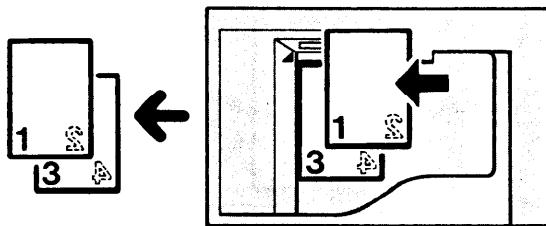

When you set originals in the dual job feeder, the last page of the originals should be on the bottom as shown.

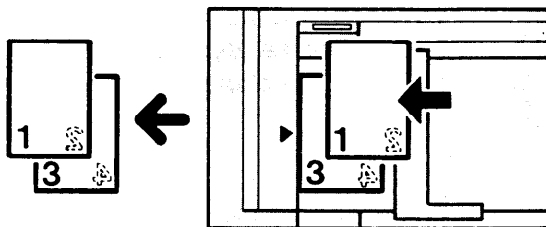

When you set originals in the recirculating document handler, the last page of the originals should be on the bottom .

**FUNCTIONS ON
OPERATION SCREENS**

Duplex/Series Copies

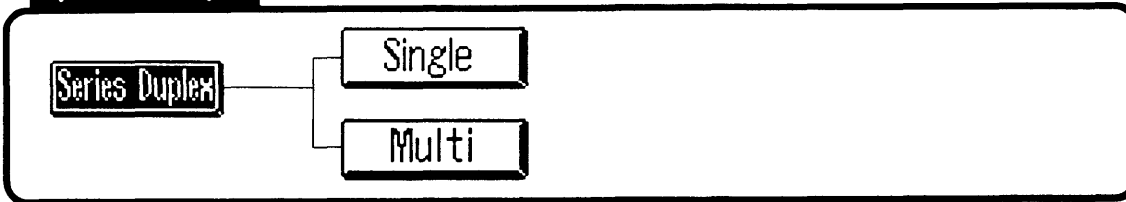

Series Duplex

- The following functions cannot be used if copy paper larger than A4 sideways or 8 1/2" x 11" sideways is selected.
- The center of an original is determined according to the selected copy paper and reproduction ratio. Make sure to select copy paper and reproduction ratio suitable for the original.

Single

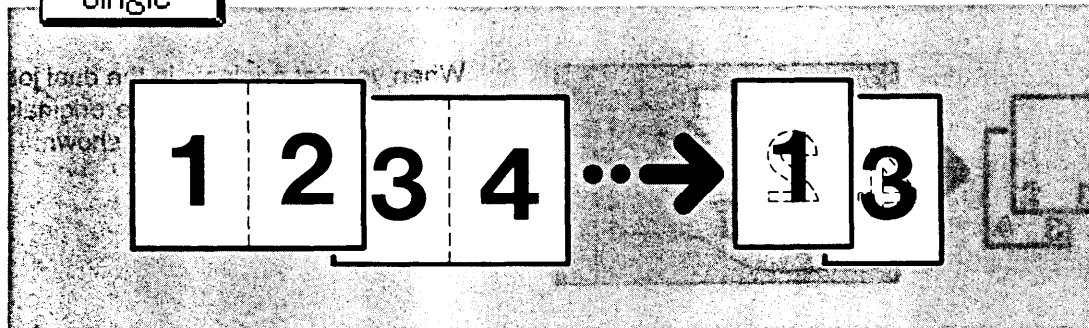

This function makes 2 sided copies from 2 facing pages of a bound (book) original.

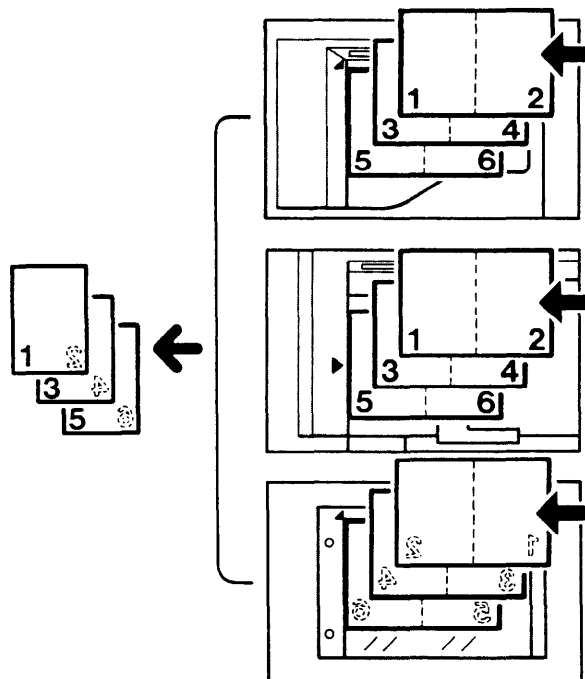

When you use the dual job feeder, the last page of the originals should be on the bottom as shown.

When you use the recirculating document handler, the last page of the originals should be on the bottom as shown.

When you place the original on the exposure glass, start with the last page of originals as shown.

- Make sure that the original binding is centered with the book mark on the rear scale.

Series Duplex

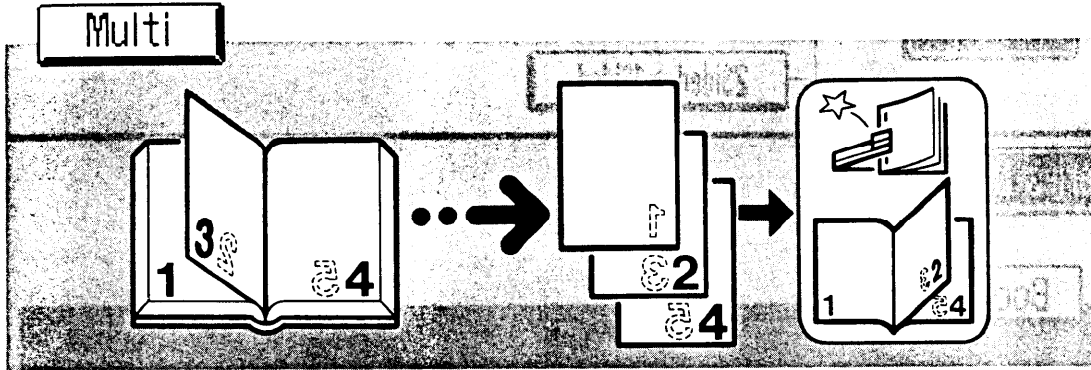

Use this function to have the copies face each other exactly as the bound (book) originals do. When you use this function, place the original on the exposure glass face down.

For bound originals read from left to right, place the original on the exposure glass with the cover right side up. You should start with the last page of the originals and the last page should be aligned to the left scale as shown.

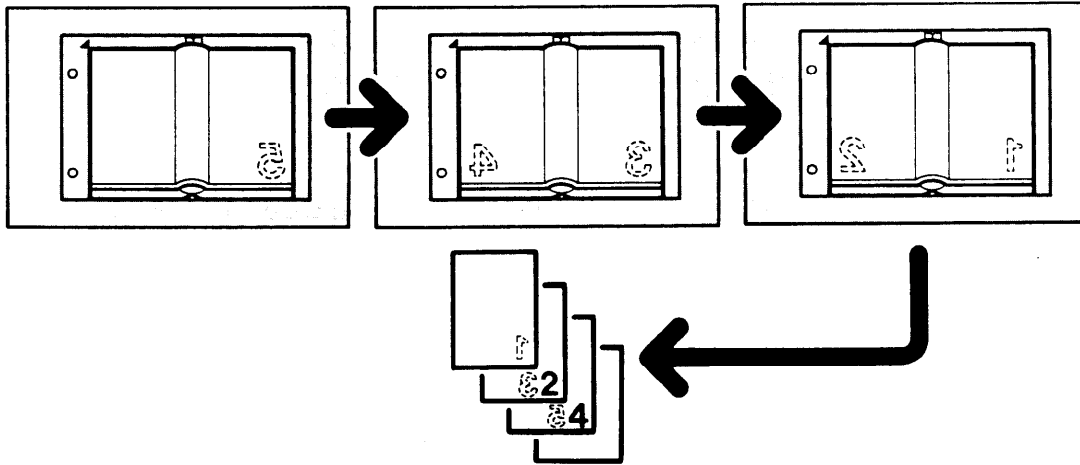

FUNCTIONS ON OPERATION SCREENS

- The center of an original is determined according to the selected copy paper and reproduction ratio. Make sure to select copy paper and reproduction ratio suitable for the original.
- Make sure that the original binding is centered with the book mark on the rear scale.
- For bound originals read from right to left, place the book with the cover upside down.
- You can use this function with the dual job feeder (system A or B) or the recirculating document handler (system C), too.

Duplex/SeriesCopies

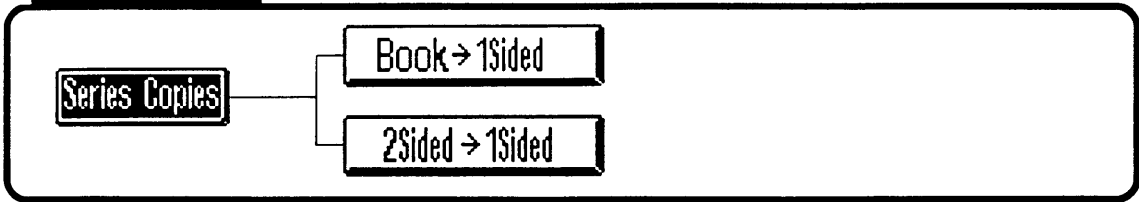

Series Copies

Book → 1Sided

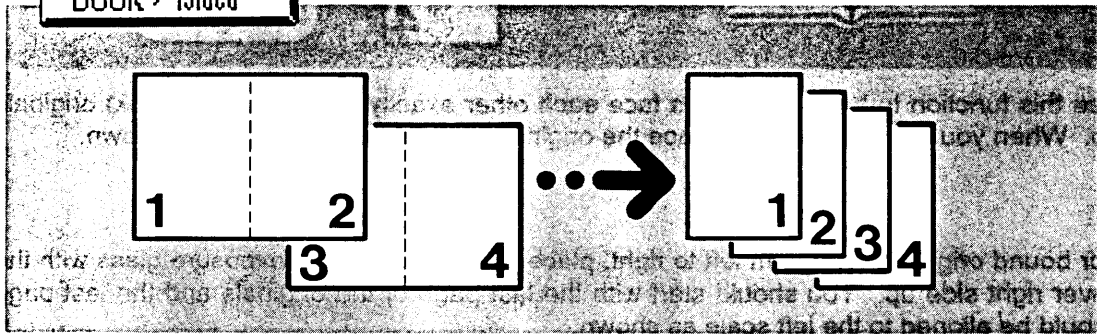

This function makes 1 sided copies from two facing pages of bound (book) originals.

- This function cannot be used if copy paper larger than A4 sideways or 8 1/2" x 11" sideways is selected.
- The center of an original is determined according to the selected copy paper and reproduction ratio. Make sure to select copy paper and reproduction ratio suitable for the original.

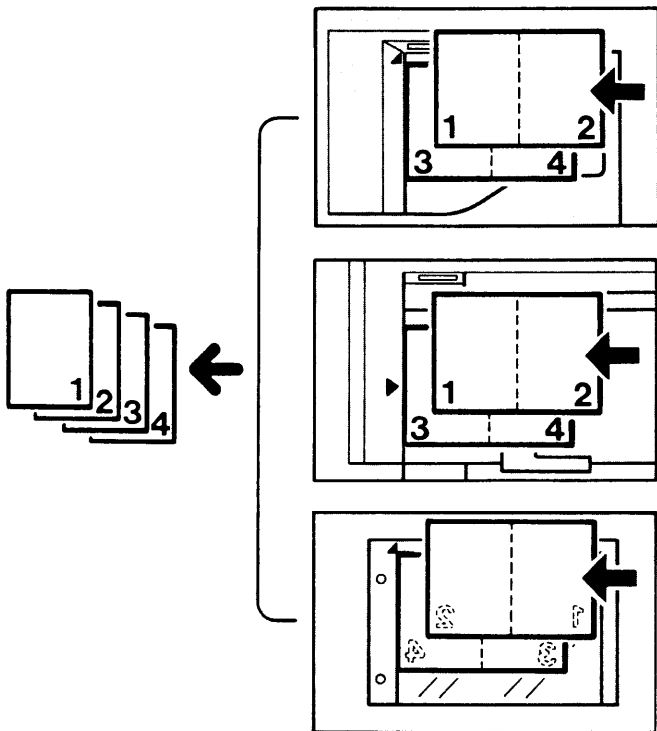

When you set originals in the dual job feeder, the last page of the originals should be on the bottom as shown.

When you set originals in the recirculating document handler, the last page of the originals should be on the bottom as shown.

When you place the original on the exposure glass, start with the last page of originals as shown.

- Make sure that the original binding is centered with the book mark on the rear scale.

Series Copies

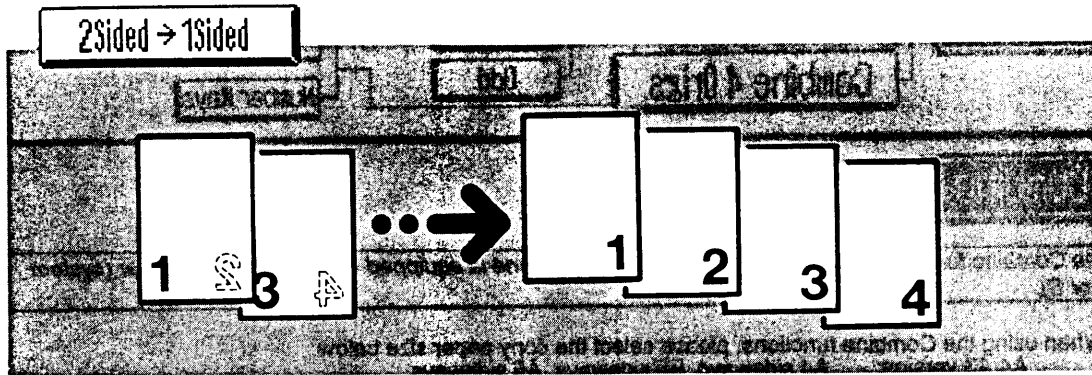

This function makes 1 sided copies from 2 sided originals.

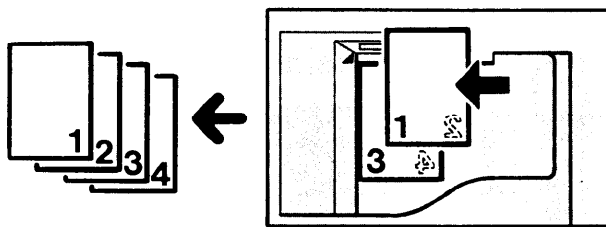

When you set originals in the dual job feeder, the last page of the originals should be on the bottom as shown.

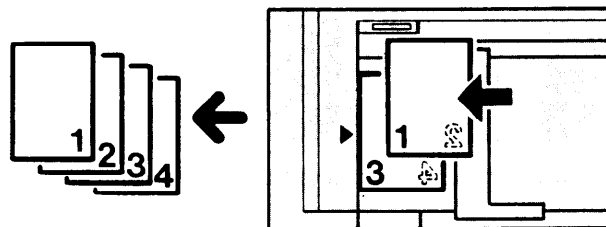

When you set originals in the recirculating document handler, the last page of the originals should be on the bottom as shown.

FUNCTIONS ON
OPERATION SCREENS

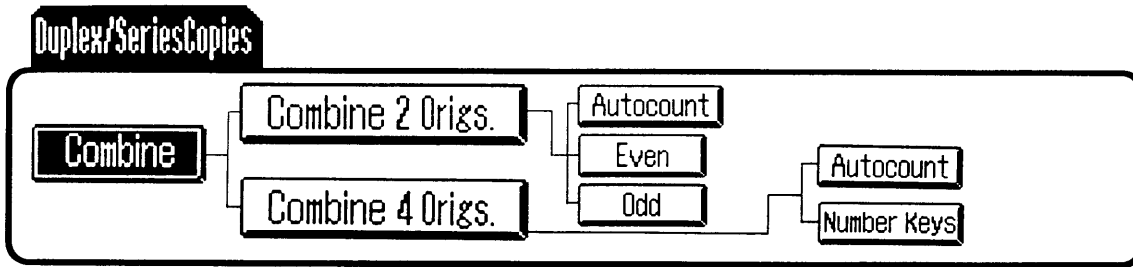

Combine

The Combine function can be used only when your machine is equipped with the dual job feeder (system A or B).

- When using the Combine functions, please select the copy paper size below.
 A4/A3 version: A4 sideways, B5 sideways, A5 sideways
 LT/DLT version: 8 1/2" x 11" sideways, 8 1/2" x 5 1/2" sideways

Combine 2 Origs.

This function automatically combines two 1 sided originals on one copy.

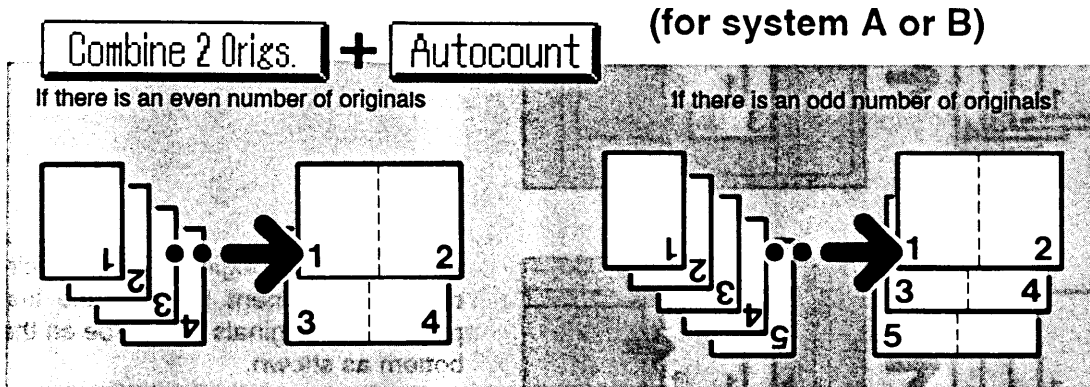

If you select the Autocount function, the machine automatically counts the number of originals.

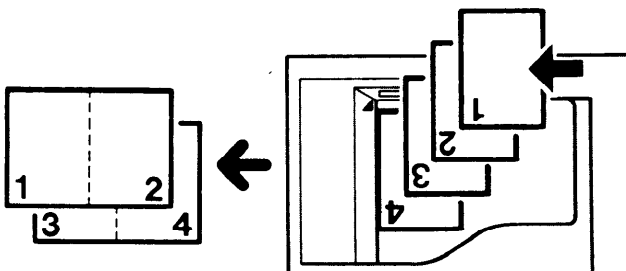

When you use the dual job feeder, the last page of the originals should be on the bottom as shown.

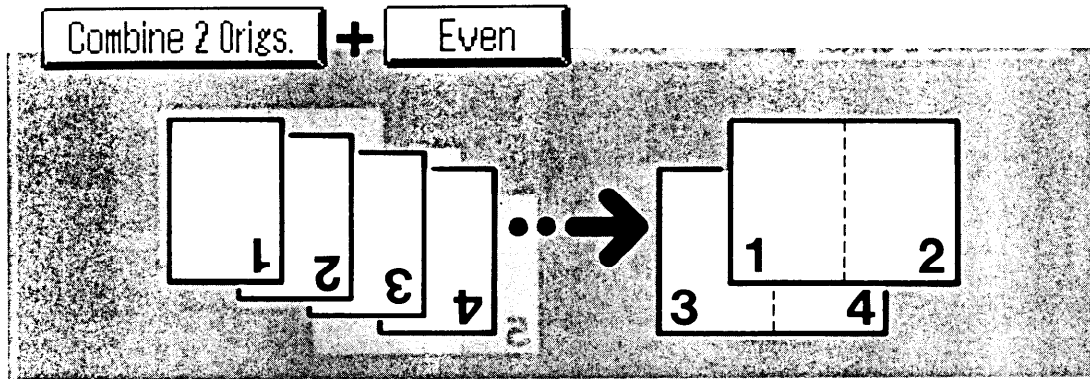

Select this key if the number of originals is even.

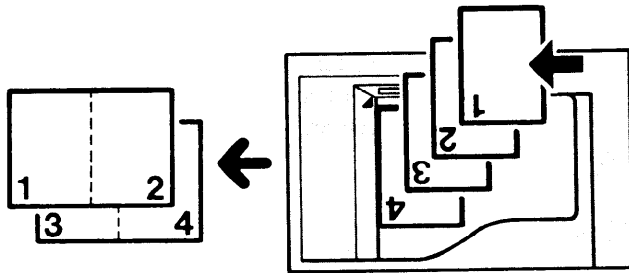

When you set originals in the dual job feeder, the last page of the originals should be on the bottom as shown.

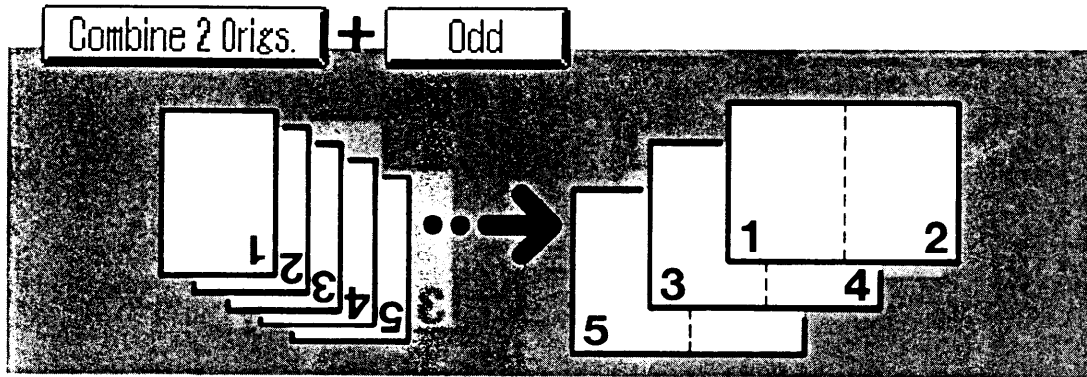

Select this key if the number of originals is odd.

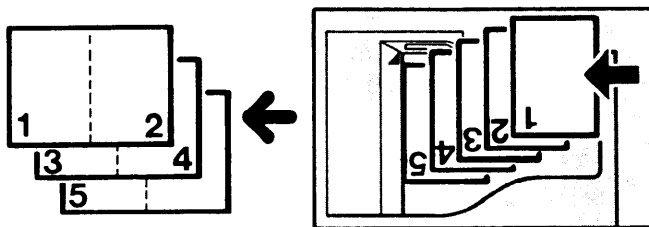

When you set originals in the dual job feeder, the last page of the originals should be on the bottom as shown.

Combine

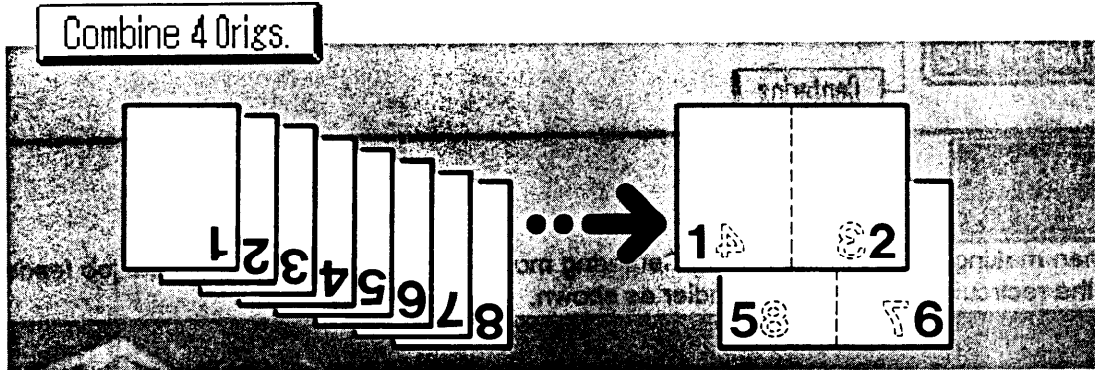

This function makes one 2 sided copy from four 1 sided originals.

- After selecting the Combine 4 Origs. function, you have to select the Autocount key or Number keys key to input the number of originals.

Example: Number of originals: 7

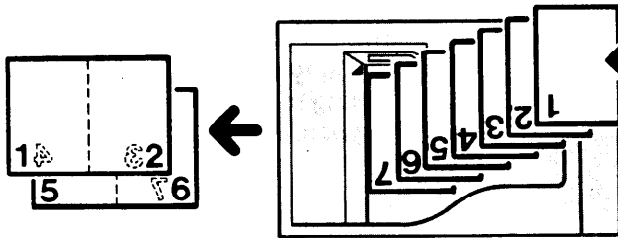

When using the dual job feeder, the last page of the originals should be on the bottom as shown.

FUNCTIONS ON
OPERATION SCREENS

Edit Image

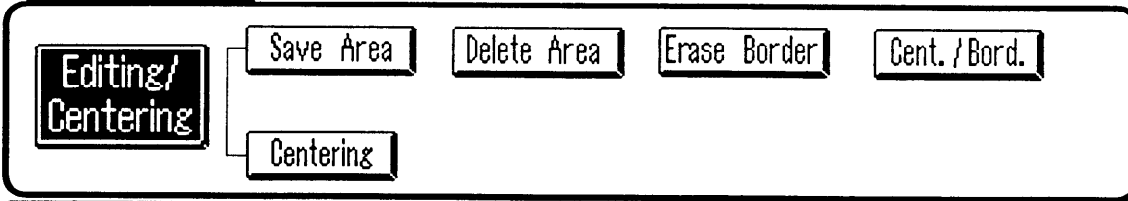

Editing/Centering

When making copies in the Editing/Centering mode, set the originals in the dual job feeder or the recirculating document handler as shown.

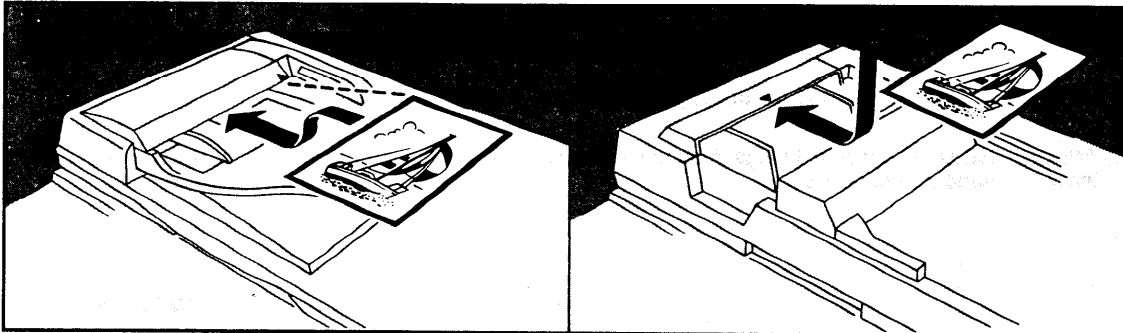

When making copies in the Editing/Centering mode, place the original on the exposure glass as shown.

- In the Save Area and the Delete Area modes, the designated line will vary by ± 5 mm (± 0.2 "). Therefore, leave at least 5 mm (0.2") between the designated line and the image. If this clearance is narrower than this, undesired image portions might be deleted or saved.

Save Area

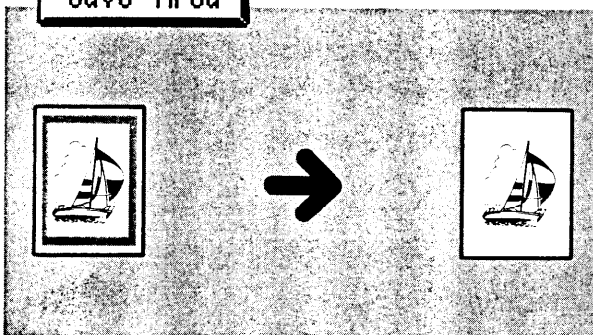

This function erases everything except the designated area.

- If you want to use an editing sheet to designate the area, please contact your sales or service representative.

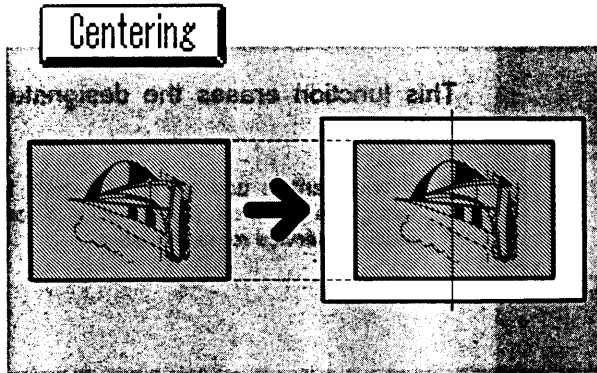

This function centers the original image on the copy.

□ When you select Centering and Save Area functions together, the copy image becomes as shown below.

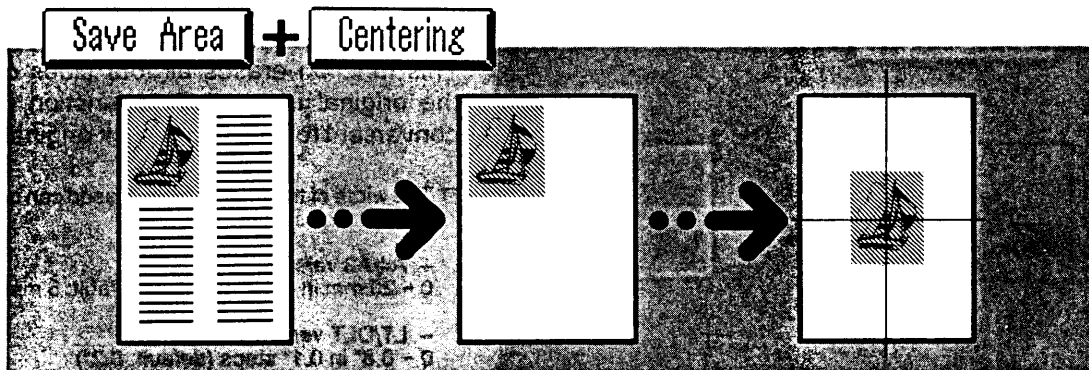

Margin Adj.

You can make margins by shifting the image to the left or right, and towards the top or bottom. This function is convenient when binding copies.

- A4/A3 version
 Maximum margin width: Left and right: 16 mm in 1 mm steps
 Top and bottom: 15 mm in 2.5 mm steps
- LT/DLT version
 Maximum margin width: Left and right : 0.6" in 0.1" steps
 Top and bottom: 0.6" in 0.1" steps
- When you make 2 sided copies from 1 sided originals, a right margin (5 mm, 0.2") is selected for the back side automatically.

Margin on 1 sided copies

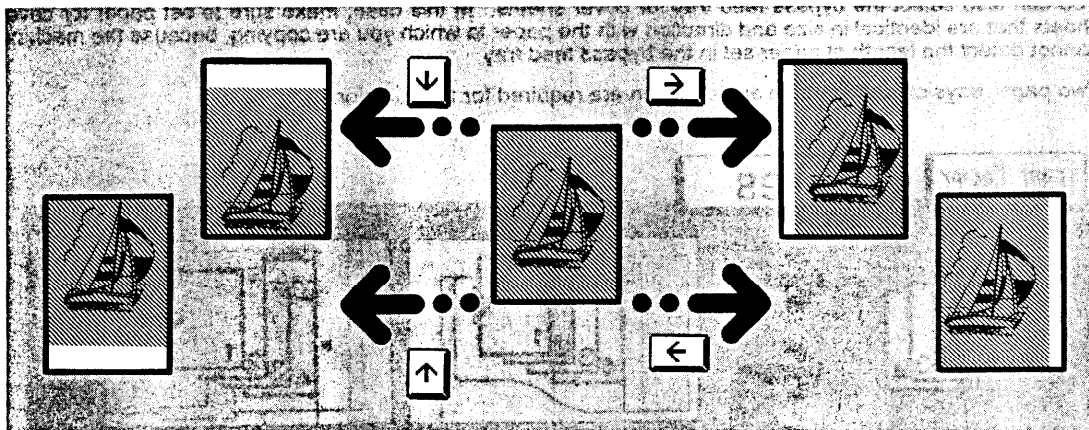

Margin on 2 sided copies

- For binding, set the left margin for the front side, and the right margin for the back side.

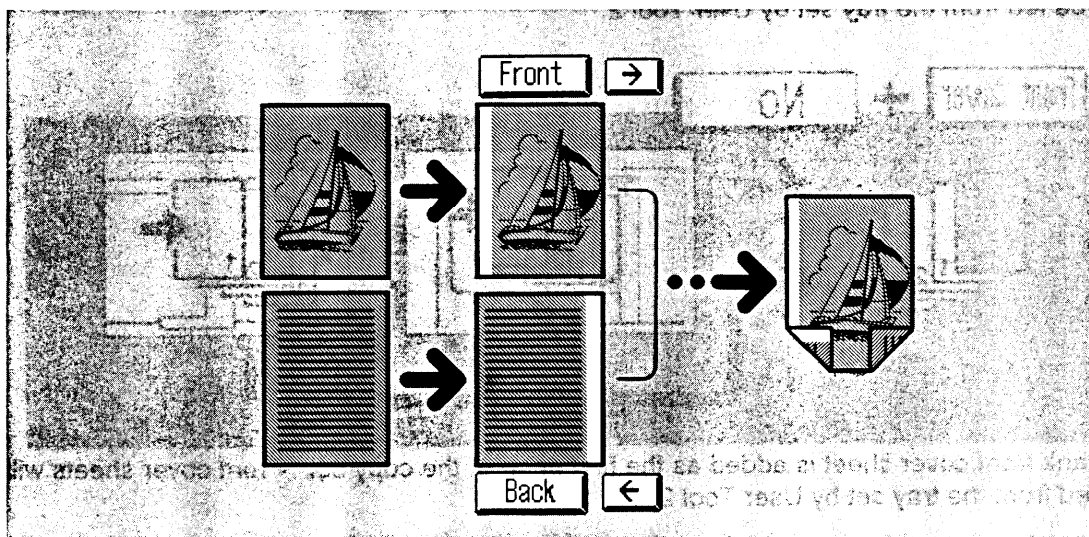

FUNCTIONS ON OPERATION SCREENS

Cover/Slip Sheet

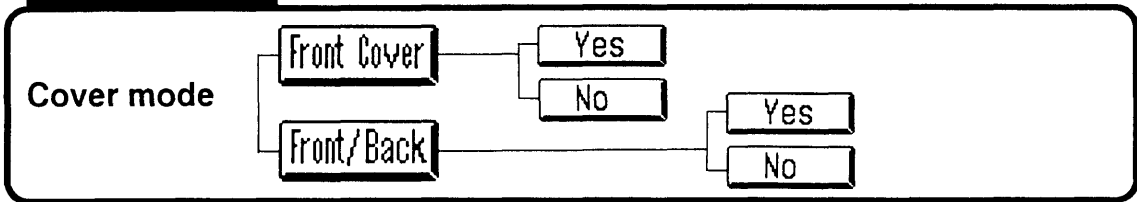

Front Cover

The Front Cover function can be used only when your machine is equipped with the dual job feeder (system A or B) or the recirculating document handler (system C).

- When using the Front Cover function, you should set the tray for cover sheets using User Tool 2. See page 15.
- You can also select the bypass feed tray for cover sheets. In this case, make sure to set paper for cover sheets that are identical in size and direction with the paper to which you are copying, because the machine cannot detect the length of paper set in the bypass feed tray.
- Two paper trays of identical size and direction are required for this function.

Front Cover + Yes

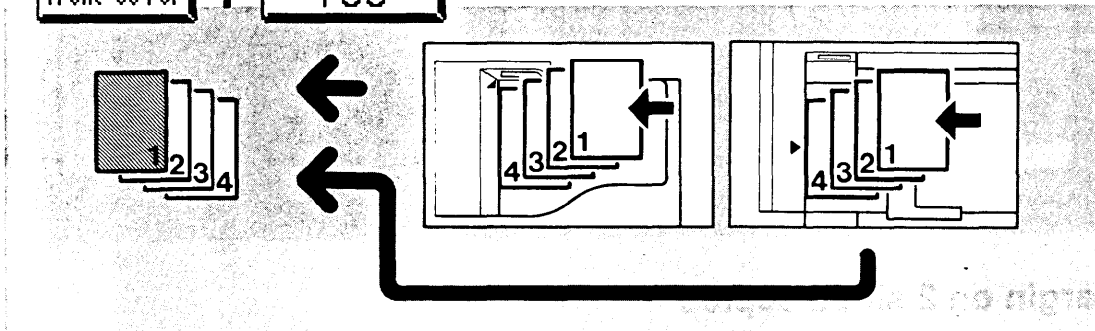

The original on the top of the stack will be copied on the front cover sheet. Front cover sheets will be fed from the tray set by User Tool 2.

Front Cover + No

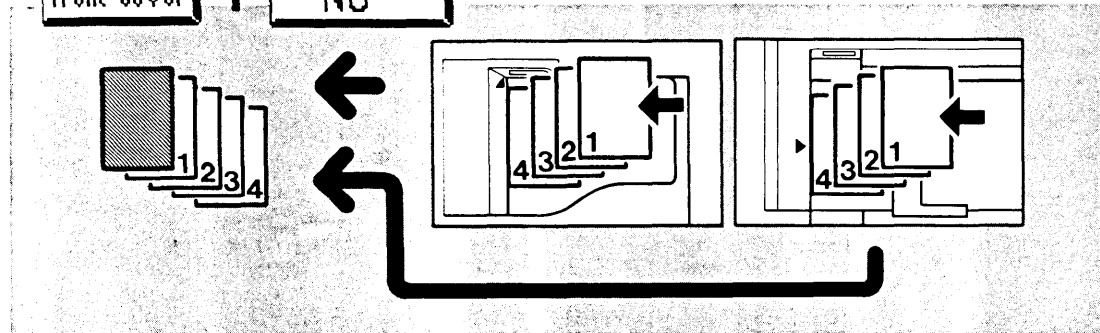

A blank front cover sheet is added as the first page of the copy set. Front cover sheets will be fed from the tray set by User Tool 2.

Front/Back

The Front/Back Covers function can be used only when your machine is equipped with the dual job feeder (system A or B), or the recirculating document handler (system C).

- When using the Front/Back Covers function, you should set the tray for cover sheets using User Tool 2. See page 15.
- You can also select the bypass feed tray for cover sheets. In this case, make sure to set paper for cover sheets that are identical in size and direction with the paper to which you are copying, because the machine cannot detect the length of paper set in the bypass feed tray.
- Two paper trays of identical size and direction are required for this function.

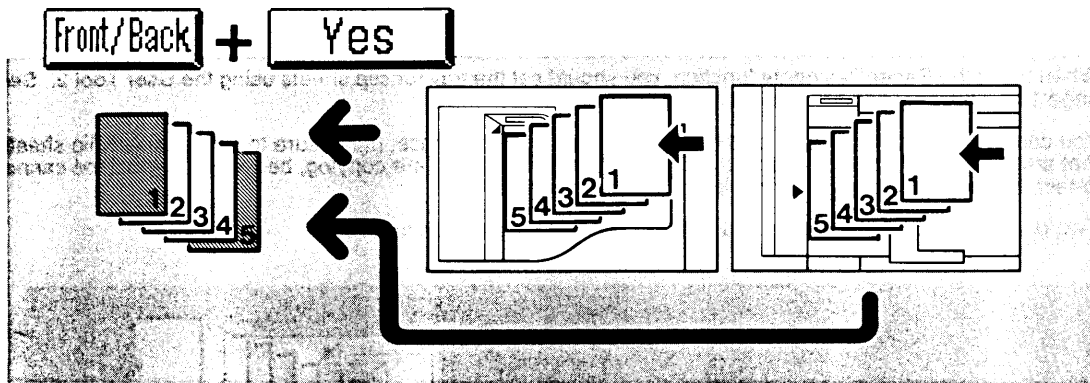

The originals on the top and bottom of the stack will be copied on cover sheets. Cover sheets will be fed from the tray set by User Tool 2.

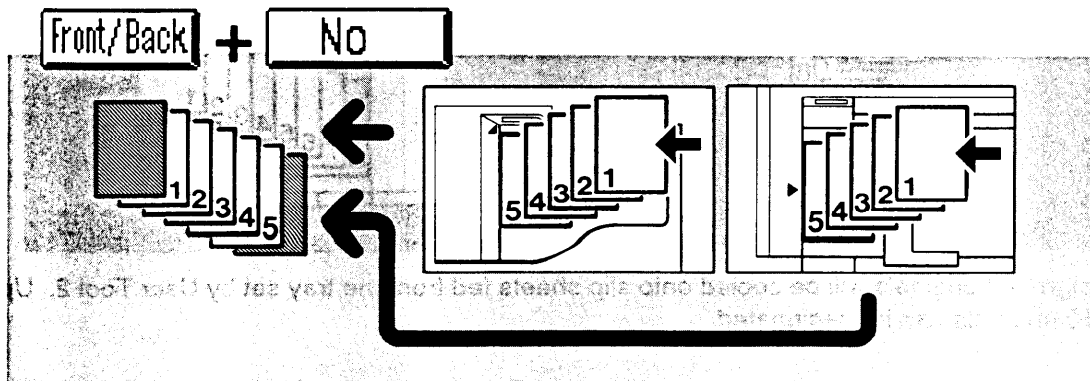

Blank front and back covers are added to the copy set. Cover sheets will be fed from the tray set by User Tool 2.

FUNCTIONS ON OPERATION SCREENS

Paper Designate

The Paper Designate function can be used only when your machine is equipped with the dual job feeder (system A or B), or the recirculating document handler (system C).

Before using this function, please refer to pages 4 and 5 to know which system you have because this function is different depending on the system you have.

System A and B (with dual job feeder)

After selecting this function, you have to select the **Autocount** key or the **Number keys** key to input the number of originals.

System C (with recirculating document handler)

After selecting this function, the machine starts counting the number of originals automatically.

- When using the Paper Designate function, you should set the tray for slip sheets using the User Tool 2. See page 15.
- You can also select the bypass feed tray for slip sheets. In this case, make sure to set paper for slip sheets that are identical in size and direction with the paper to which you are copying, because the machine cannot detect the length of paper set in the bypass feed tray.
- Two paper trays of identical size and direction are required for this function.

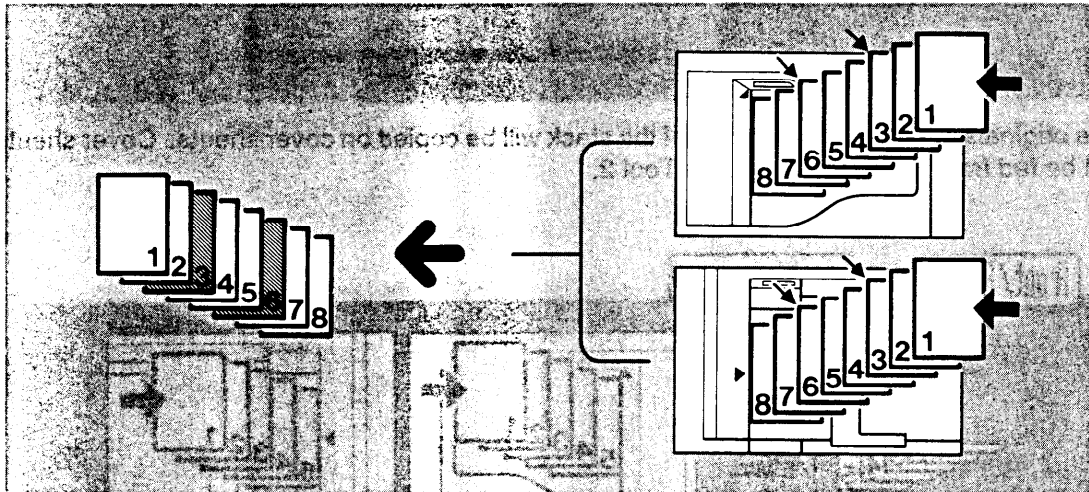

Designated originals will be copied onto slip sheets fed from the tray set by User Tool 2. Up to 10 originals can be designated.

OHP Slip Sheet

- When using the OHP slip sheet function, you should set the tray for slip sheets using User Tool 2. See page 15.
- You can also select the bypass feed tray for slip sheets. In this case, make sure to set paper for slip sheets that are identical in size and direction with the paper to which you are copying, because the machine cannot detect the length of paper set in the bypass feed tray.
- Two paper trays of identical size and direction are required for this function.

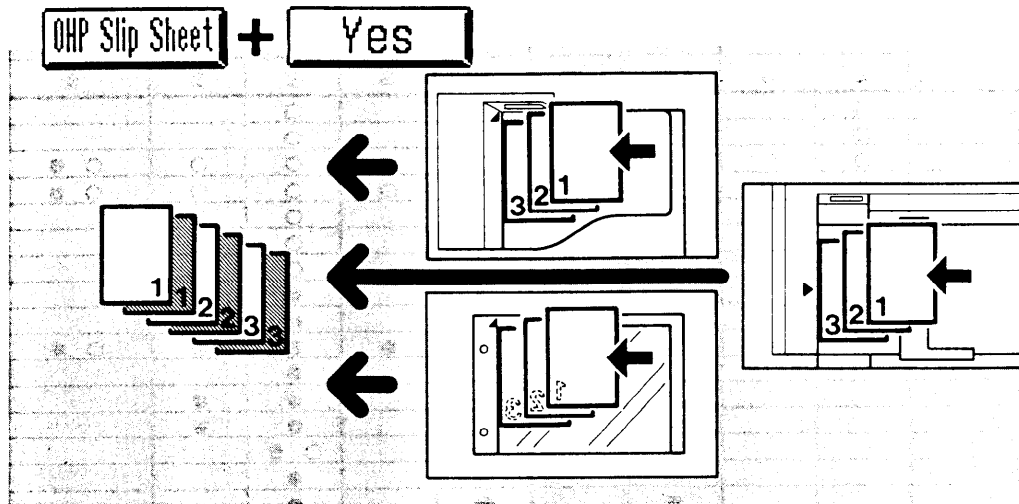

Whenever a different original is copied, a slip sheet will be fed and the same original image is copied onto this slip sheet.

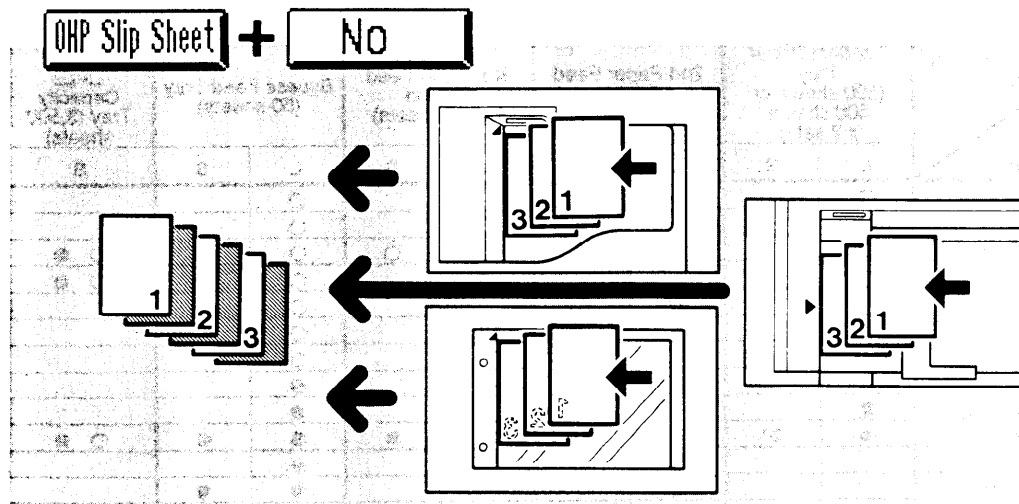

Whenever a different original is copied, a blank slip sheet is placed after each copy.

LOADING PAPER

The following paper sizes can be set.

Copier type 1

Paper Feed Station Paper Size	1st Paper Feed Station (550 sheets)		2nd Paper Feed Station (550 sheets)		3rd Paper Feed Station (550 sheets)		Bypass Feed Tray (50 sheets)		Optional Large Capacity Tray (3,500 sheets)
	L	S	L	S	L	S	L	S	S
A3	○		○		○		○		
B4	○				○		○		
A4	○	○	○	○	○	○	○	○	○ ●
B5	○	○			○	○	○	○	○ ●
A5			☆	○	○		○	○	
B6							○		
A6							○		
11" x 17"	●		●		●		●		
8 1/2" x 14"	●		●		●		●		
8 1/2" x 11"	●	●	●	●	●	●	●	●	○ ●
8 1/2" x 13" (F4)			○		●		●		
8" x 10 1/2"			●		●		●	●	
8" x 10"			●		●		●	●	
8" x 13" (F)			●		●		○ ●		
8 1/4" x 13"			○		●		●		
10" x 14"			●		●		●		
11" x 15"			●		●		●		
5 1/2" x 8 1/2"			☆	●	●		●	●	

Copier type 2

Paper Feed Station Paper Size	Tandem Paper Tray (500 sheets or 500 sheets x 2 sets)		2nd Paper Feed Station (550 sheets)		3rd Paper Feed Station (1,500 sheets)		Bypass Feed Tray (50 sheets)		Optional Large Capacity Tray (3,500 sheets)
	L	S	L	S	L	S	L	S	S
A3	○		○				○		
B4	○				○		○		
A4	○	○*	○	○	○	○	○	○	○ ●
B5	○	○*			○	○	○	○	○ ●
A5			☆	○			○	○	
B6							○		
A6							○		
11" x 17"	●		●				●		
8 1/2" x 14"	●		●		●		●		
8 1/2" x 11"	●	●*	●	●	●	●	●	●	○ ●
8 1/2" x 13" (F4)			○		●		●		
8" x 10 1/2"			●				●	●	
8" x 10"			●				●	●	
8" x 13" (F)			●				○ ●		
8 1/4" x 13"			○				●		
10" x 14"			●				●		
11" x 15"			●				●		
5 1/2" x 8 1/2"			☆	●			●	●	

"L" means lengthwise.

"S" means sideways.

○ can be used for A4/A3 version machines.

● can be used for LT/DLT version machines.

○*: 2 sets of 500 sheets can be set in A4/A3 version machines.

●*: 2 sets of 500 sheets can be set in LT/DLT version machines.

✱ can be set by your service representative for A4/A3 version machines.

✱* can be set by your service representative for LT/DLT version machines.

- You can change the paper size of the 2nd feed station and bypass feed tray. If you want to change the paper size of other trays, or to select A5 lengthwise (✱) or 5 1/2" x 8 1/2" lengthwise (✱*) for the 2nd feed station, please contact your service representative.

Note

- Adhesive labels should be fed from the bypass feed tray one sheet at one time.
- Do not use copy paper that has been already copied on.
- OHP transparencies should be fanned to get air between the sheets before loading.
- OHP transparencies should be fed lengthwise.

Non-recommended Paper

- Folded, curled, creased, or damaged paper
- Torn paper
- Perforated paper
- Paper with any kind of coating
- Thermal paper, art paper, silver coated paper, carbon
- Paper with low electrical resistance (for example, aluminum)
- Thin paper that has low stiffness

550-sheet Paper Tray

- For copier type 1 (1st, 2nd and 3rd feed station)
For copier type 2 (2nd feed station)
- You can change the paper size of the 2nd feed station. See page 73.

1. Pull out the paper tray until it stops.

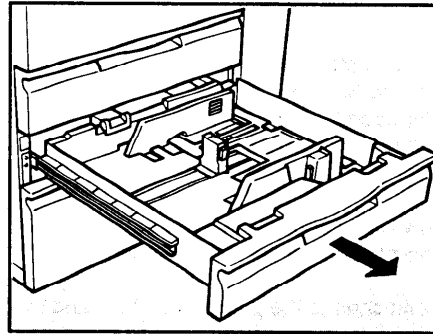

2. Load paper in the paper tray.

- The paper stack must be flush with the right side of the paper tray.
- Make sure to read the notice on the package showing the front side (copy side) of the paper. Load paper with the copy side down.

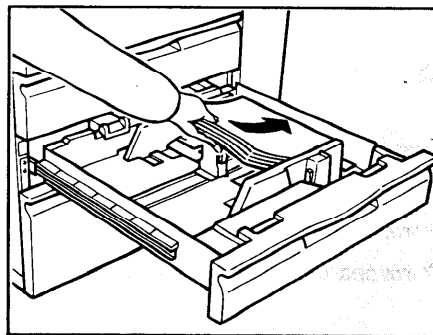

- Do not stack paper over the limit mark.

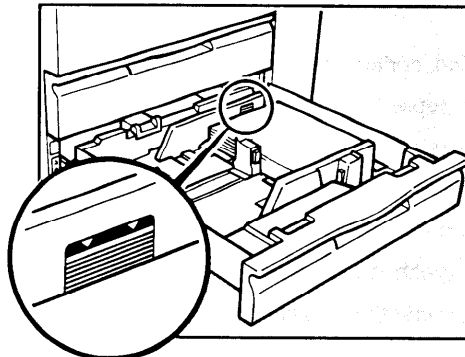

3. Push the tray until it stops.

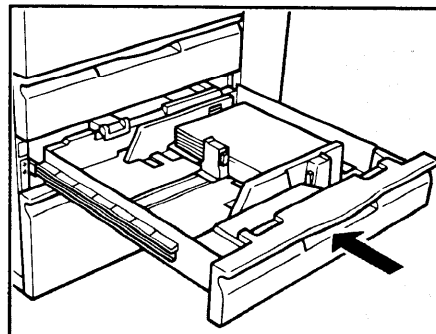

Tandem Paper Tray

- For copier type 2 (1st feed station)
- Before loading paper in the tandem tray, refer to the following flow chart.

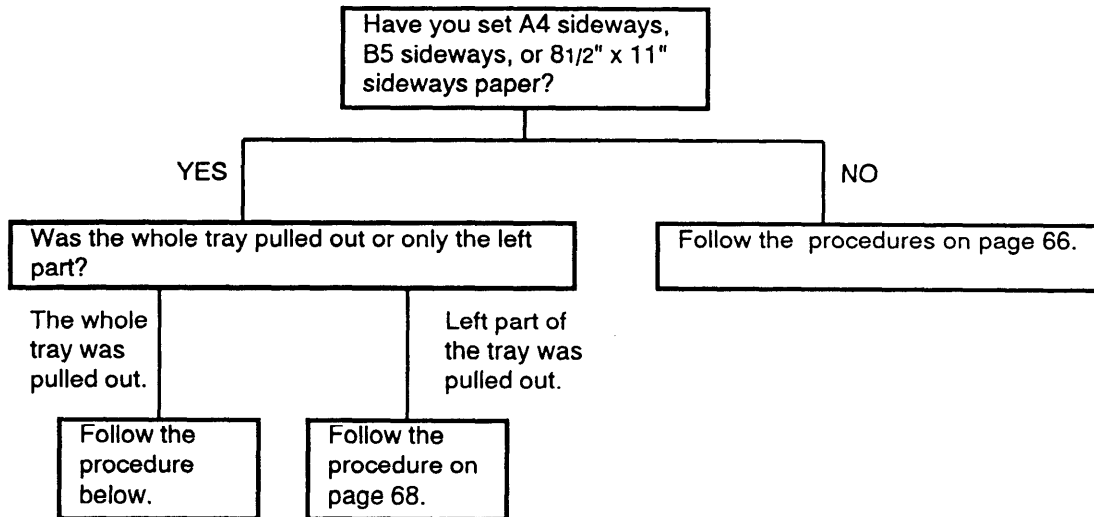

If the whole tray is pulled out:

1. Load paper in the left part of the paper tray.
 - The paper stack must be flush with the left side of the paper tray.
 - Do not stack paper over the limit mark.
 - Make sure to read the notice on the package showing the front side (copy side) of the paper. Load paper with the copy side down.

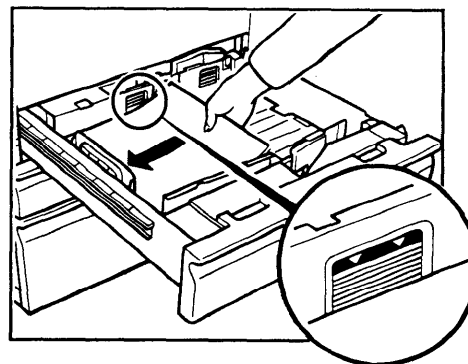

2. Load paper in the right part of the paper tray.

- The paper stack must be flush with the right side of the paper tray.
- Do not stack paper over the limit mark.
- Make sure to read the notice on the package showing the front side (copy side) of the paper. Load paper with the copy side down.

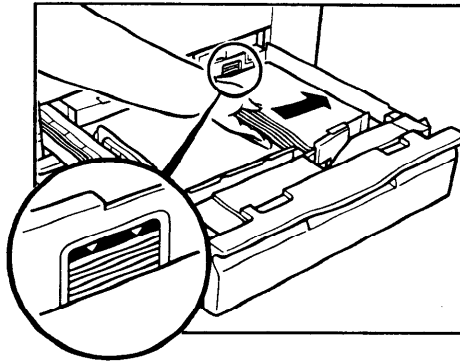

3. Push the tray until it stops.

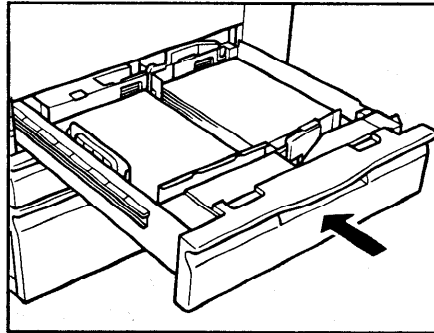

If left part of the tray is pulled out:

1. Load paper in the left part of the paper tray.

- The paper stack must be flush with the left side of the paper tray.
- Do not stack paper over the limit mark.
- Make sure to read the notice on the package showing the front side (copy side) of the paper. Load paper with the copy side down.

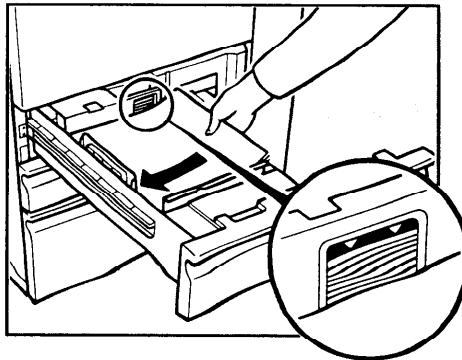

2. Push the tray until it stops.

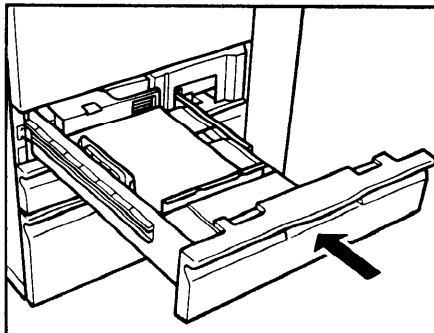

1,500-sheet Large Capacity Tray

□ For copier type 2 (3rd feed station)

1. Press the **Down** key to lower the bottom plate. The **Down** key starts blinking.

□ If paper has run out, the bottom plate lowers automatically and the **Down** key is lit. In this case, you need not press the **Down** key.

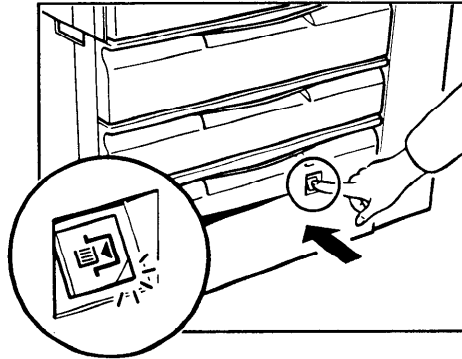

2. After the **Down** key stops blinking and lights, pull out the tray until it stops.

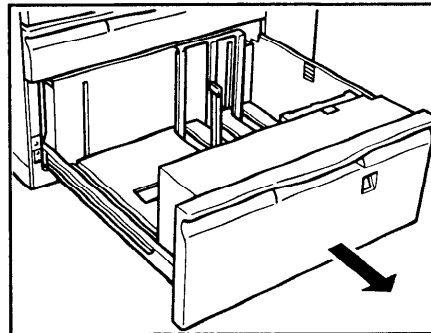

3. Load paper in the paper tray.

□ The paper stack must be flush with the right side of the paper tray.

□ Make sure to read the notice on the package showing the front side (copy side) of the paper. Load paper with the copy side down.

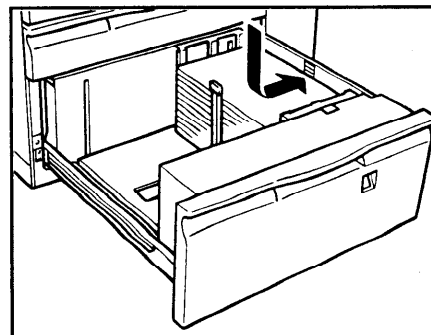

□ Do not stack paper over the limit mark.

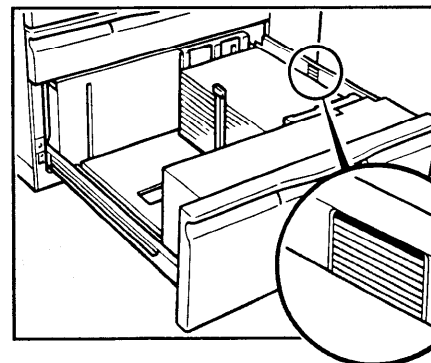

LOADING PAPER

3. Push the tray until it stops.

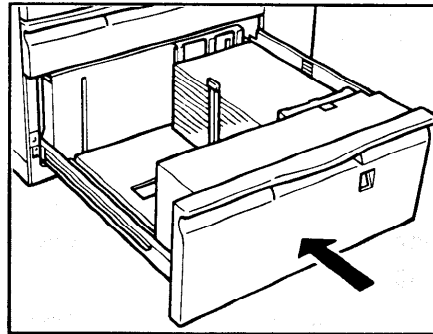

Optional 3,500-sheet Large Capacity Tray

1. Open the cover of the large capacity tray.

- When opening the cover, hold it by the lip.

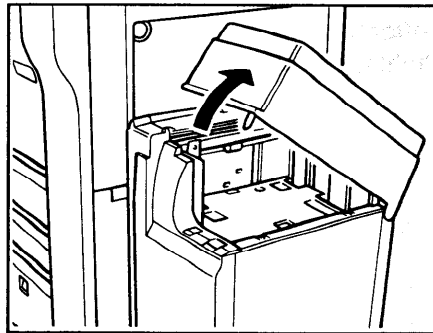

2. Press the **Down** key to lower the bottom plate. The **Down** key starts blinking.

- If paper has run out, the bottom plate lowers automatically and the **Down** key is lit. In this case, you need not press the **Down** key.

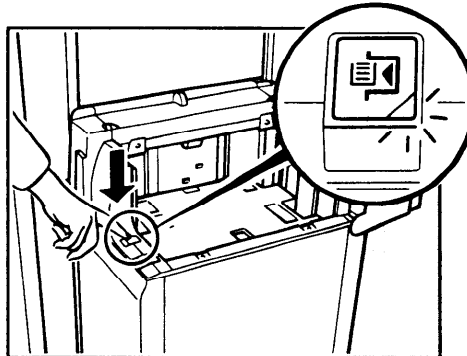

3. After the **Down** key stops blinking and lights, load paper in the large capacity tray.

- 500 sheets of copy paper can be loaded at one time.
- The paper stack must be flush with the left side of the tray.
- Make sure to read the notice on the package showing the front side (copy side) of the paper. Load paper with the copy side up.

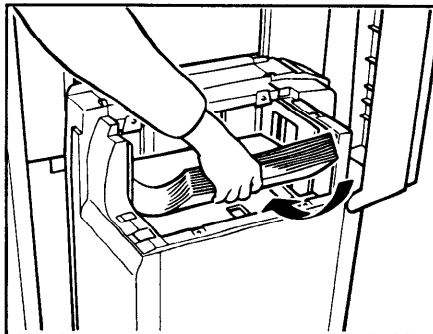

4. Repeat steps 2 and 3.
5. Close the cover.

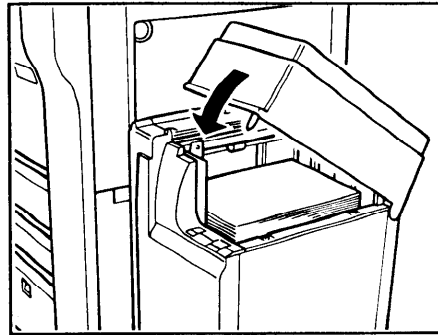

Bypass Feed Tray

1. Open the bypass feed tray.
2. Slide the paper guides to the paper width.
3. If you use copy paper larger than A4 sideways or 8 1/2" x 11" sideways, pull out the paper support guide.

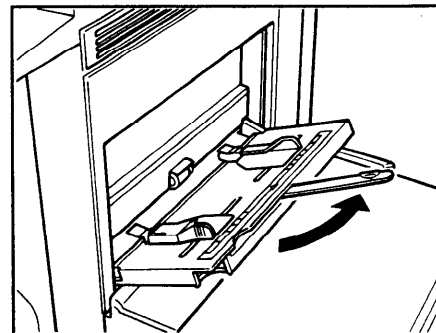
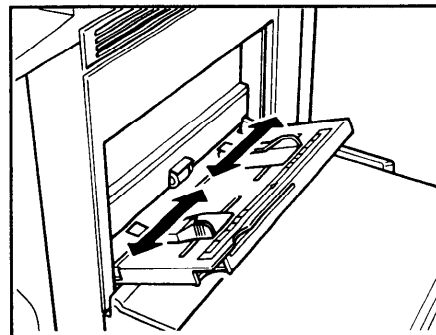
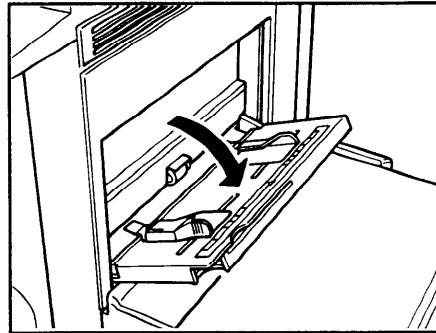

LOADING PAPER

4. Insert the copy paper.

- ❑ Make sure to read the notice on the package showing the front side (copy side) of the paper. Load paper with the copy side up.

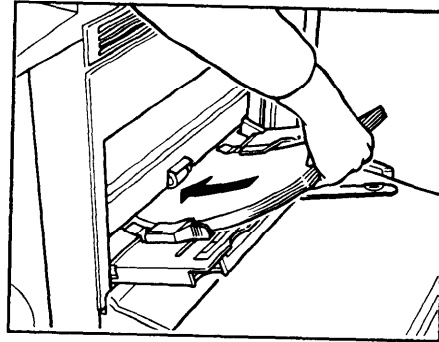

5. After copying is completed, close the bypass feed tray.

CHANGING PAPER SIZE

□ You can change the paper size of the 2nd tray. If you want to change the paper size of other trays, please contact your sales or service representative.

1. Pull out the 2nd paper tray until it stops.

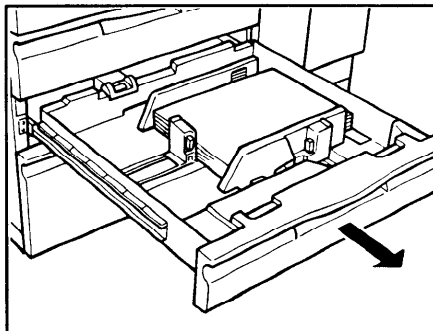

2. Remove copy paper.

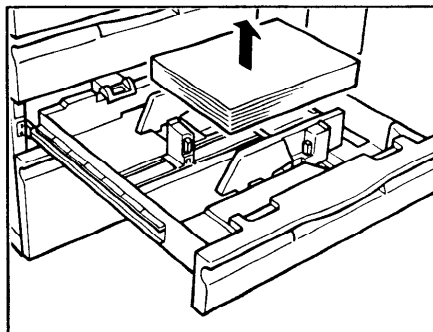

3. While pressing the release lever on the front side guide, slide the front and rear guides to the paper size you want to use.

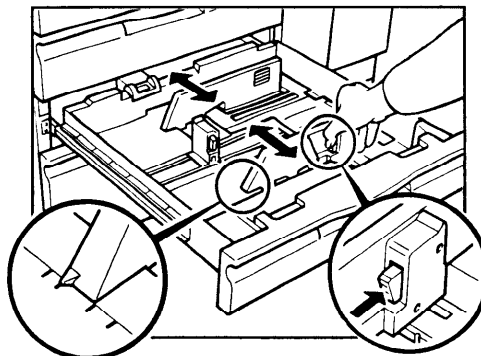

4. While pressing the left guide release lever, slide the left guide to the paper size you want to use.

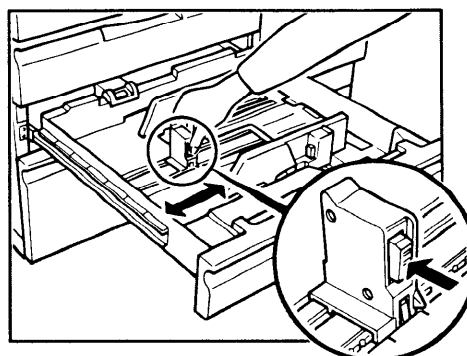

CHANGING PAPER SIZE

5. Select the paper size by adjusting the paper size selector on the back side of the tray.

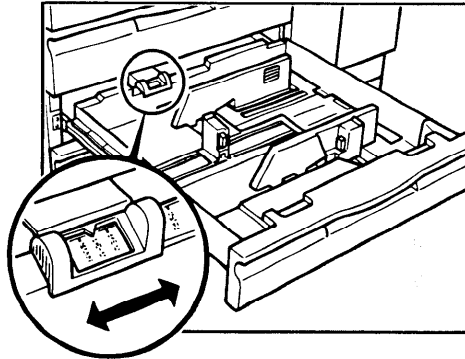

6. Load paper.

- The paper stack must be flush with the right side of the tray.
- Do not stack paper over the limit mark.
- Make sure to read the notice on the package showing the front side (copy side) of the paper. Load paper with the copy side down.

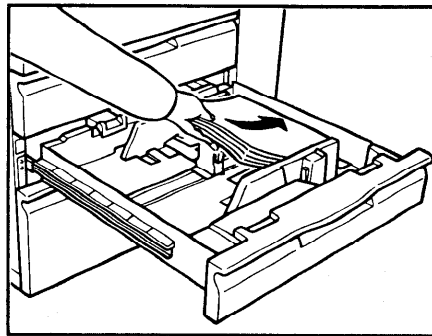

7. Adjust the front, rear and left guides flush with the paper stack.

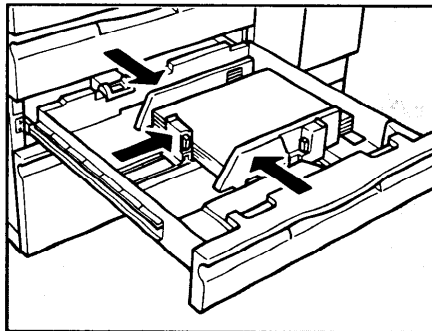

8. Push the tray until it stops.

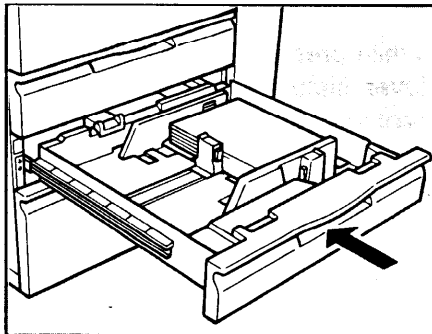

WHAT TO DO WHEN THINGS GO WRONG

Problem	Action
Nothing happens when the main switch is turned on.	Check the power cord. If it is not plugged properly, plug it firmly into the outlet.
The Start key does not change from red to green after the main switch is turned on, or the machine stops during a copy run.	Check the touch panel display, and follow the instructions.

WHAT TO DO WHEN
THINGS GO WRONG

Problem	Cause	Action
Copies appear dirty.	Image density level is too dark.	Lower the image density level. ➤ See page 35.
		Lower the image density level using User Tool No. 5. ➤ See page 16.
The reverse side of an original image is copied.	Image density level is too dark.	Lower the image density level. ➤ See page 35.
		Lower the image density level using User Tool No. 5. ➤ See page 16.
The same copy area is dirty whenever making copies.	The exposure glass, dual job feeder belt, or recirculating document handler belt is dirty.	Clean the required parts. ➤ See pages 78 ~ 80.
Copies are too light.	Image density level is too light.	Select the darker image density level. ➤ See page 35.
		Select the darker image density level using User Tool No. 5. ➤ See page 16.
Parts of the original image are not copied.	Originals are not set correctly.	Set the originals correctly. ➤ See pages 19 ~ 34.
	You've selected an incorrect paper size.	Select copy paper of the proper size.
The original image is not copied.	Originals are not set correctly.	Set the originals correctly. ➤ See pages 19 ~ 34.

□ If you cannot correct the problem by taking the actions above, please contact your service representative.

USER REMARKS

Problem	Cause	Action
Staples do not come out at all.	You loaded the new staple cartridge.	After loading the new staple cartridge, staples may not be ejected the first few times you try to use the stapler.
	There are jammed staples in the stapler.	Compact sorter stapler (system A) > Remove the jammed staples following the instructions inside the sorter stapler cover
		Floor type sorter stapler (system B) > Call your service representative.
	Finisher (system C) > Call your service representative.	

If you cannot correct the problem by taking the actions above, please contact your service representative.

USER REMARKS

Narrow margins at the leading and side edges of original are not copied. See the illustration below.

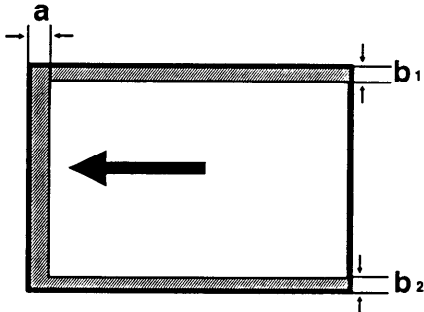

1 sided copy

$a = 3.5 \pm 2.5 \text{ mm}$ $b1 + b2 \leq 3 \text{ mm}$

1 sided copy (A6)

$a = 3.5 \pm 2.5 \text{ mm}$ $b1 + b2 = 5 \text{ mm}$

Back side of 2 sided copy

In Full Size mode

$a = 8.5 \pm 3 \text{ mm}$ $b1 + b2 \leq 3 \text{ mm}$

Not in Full Size mode

$a \leq 4 \text{ mm}$ $b1 + b2 \leq 3 \text{ mm}$

DO'S AND DON'TS

WHEN ADDING TONER

WARNING: Do not incinerate toner or toner containers. Toner dust may ignite when exposed to open flame.

WARNING: Dispose of the used toner cartridge according to your local regulations.

- When adding toner, follow the instructions on the touch panel display.
- Do not turn off the main switch. If you do, your copy settings are cleared.

WHEN REMOVING MISFED PAPER

WARNING: Since some parts of the copier are supplied with high electrical voltage, touch only the parts specified in the instructions inside the machine door.

WARNING: When removing misfed paper from section "D", use caution. The fusing unit may be very hot.

- When removing misfed paper, follow the instructions on the touch panel display.
- Do not turn off the main switch. If you do, your copy settings are cleared.
- Do not leave any torn scraps within the machine.
- After removing misfed paper, make sure that all units and levers are returned to their original positions and that all covers are closed.
- When removing misfed paper from the dual job feeder, open the cover of the feed-in unit.

GENERAL OPERATION

- In the Staple mode, do not use paper that is curled or has low stiffness.
- When you use the bypass feed tray while placing the original directly on the exposure glass, lower the platen cover, dual job feeder, or recirculating document handler before pressing the Start key.

DAILY MAINTENANCE

To maintain high copy quality, clean the following parts and units regularly.

Copier

Touch Panel Display

Clean the touch panel display with a dry soft cloth.

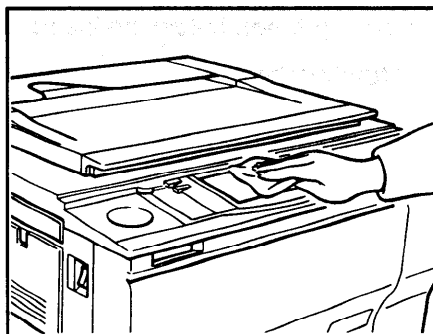

Exposure Glass

1. Lift the platen cover, dual job feeder or recirculating document handler.
2. Clean the exposure glass with a damp cloth and wipe it with a dry cloth.
 - If stains do not come off, use a glass cleaner. After using a glass cleaner, wipe it with a dry cloth.

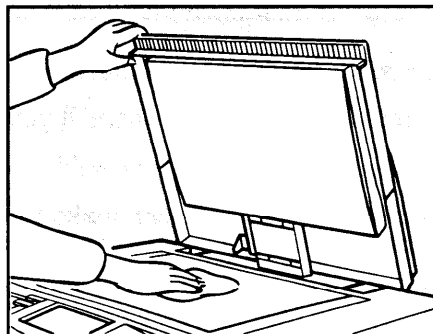

Platen Cover

1. Lift the platen cover.
2. Clean the platen cover with a damp cloth and wipe it with a dry cloth.

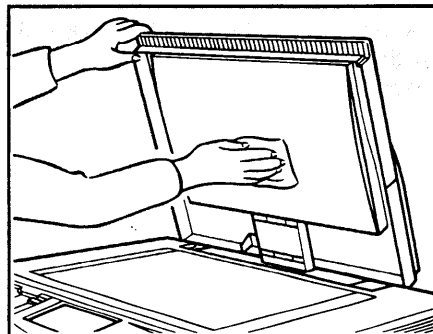

Dual Job Feeder

Belt

1. Lift the dual job feeder.
2. Clean the belt with a damp cloth and wipe it with a dry cloth.
 - If stains do not come off, use belt cleaner.

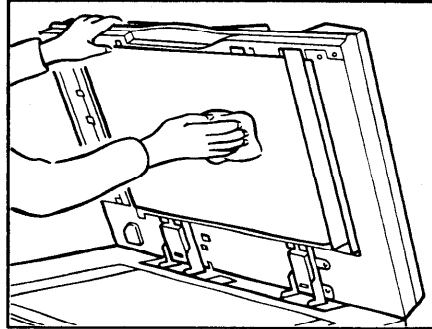

Feed-in Unit

Clean the original table and original guide with a damp cloth and wipe them with a dry cloth.

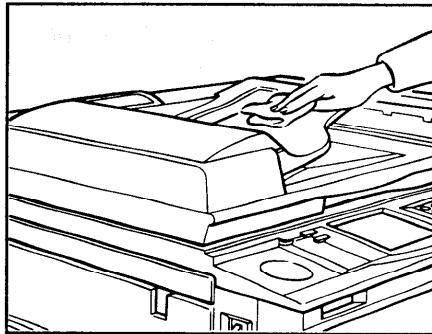

Recirculating Document Handler

Belt

1. Lift the recirculating document handler.
2. Clean the belt with a damp cloth and wipe it with a dry cloth.
 - If stains do not come off, use belt cleaner.

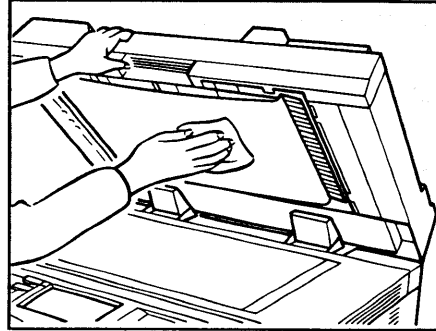

Feed-in Unit

Clean the original stacker and original guides with a damp cloth and wipe them with a dry cloth.

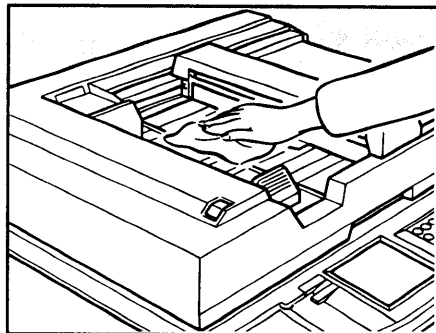

SPECIFICATIONS

Copier

Configuration:	Console
Process:	Dry electrostatic transfer system
Originals:	Sheet, book
Original Size:	Maximum: A3, 11" x 17"
Copy Paper Size:	See pages 64 and 65.
Copy Paper Weight:	Paper tray: 52 ~ 128 g/m ² , 14 ~ 34 lb Bypass feed tray: 52 ~ 157 g/m ² , 14 ~ 42 lb Duplex copying: 64 ~ 104 g/m ² , 17 ~ 24 lb
Copy Paper Capacity:	See pages 64 and 65.
Copying Speed:	Type 1: 45 copies/minute (A4 sideways, 8 1/2" x 11" sideways) 23 copies/minute (A3, 11" x 17") Type 2: 55 copies/minute (A4 sideways, 8 1/2" x 11" sideways) 28 copies/minute (A3, 11" x 17")
First Copy Time:	Type 1: 3.1 seconds (A4 sideways, 8 1/2" x 11" sideways, from 1st feed station) Type 2: 3.1 seconds (A4 sideways, 8 1/2" x 11" sideways, from 1st feed station)
Toner Replenishment:	Bottle exchange (1,100 g)
Power Source:	Please see the back side of the front cover.

Reproduction Ratio:

	A4/A3version	LT/DLT version
Enlargement	50%	50%
	65%	65%
	71%	74%
	75%	77%
	82%	85%
	93%	93%
Full Size	100%	100%
Reduction	115%	121%
	122%	129%
	141%	155%
	200%	200%

Power Consumption:

Type 1 and 2

	Copier only	Full system*
Warm-up	0.9 KVA	0.9 KVA
Stand-by	0.25 KVA	0.25 KVA
Copying	1.2 KVA	1.3 KVA
Maximum	1.45 KVA	1.5 KVA

*Full system:

Copier with dual job feeder, compact sorter stapler, and 3,500-sheet large capacity tray

Copier with dual job feeder, floor type sorter stapler, and 3,500-sheet large capacity tray

Copier with recirculating document handler, finisher, and 3,500-sheet large capacity tray

Noise Emission

Sound pressure level:
The measurements are
made according to
ISO7779.

Type 1 and 2

	Copier only	Full system*
Copying	55 dB(A)	61 dB(A)

***Full system:**

Copier with dual job feeder, compact sorter stapler and 3,500-sheet large capacity tray

Copier with dual job feeder, floor type sorter stapler and 3,500-sheet large capacity tray

Copier with recirculating document handler, finisher and 3,500-sheet large capacity tray

Dimensions (W x D x H):

	Width	Depth	Height
Copier with copy tray, platen cover	1,280 mm (50.4")	690 mm (27.2")	1020 mm (40.2")
Copier with copy tray, platen cover, 3,500-sheet large capacity tray	1,347 mm (53.1")	690 mm (27.2")	1020 mm (40.2")
Copier with dual job feeder, compact sorter stapler, 3,500-sheet large capacity tray	1,422 mm (60.0")	690 mm (27.2")	1096 mm (43.2")
Copier with dual job feeder, floor type sorter stapler, 3,500-sheet large capacity tray	1,568 mm (61.7")	690 mm (27.2")	1,096 mm (43.2")
Copier with recirculating document handler, finisher, 3,500-sheet large capacity tray	1,673 mm (65.9")	690 mm (27.2")	1,122 mm (44.2")

Weight:

Type 1

	Weight
Copier	151 kg (332.9 lb)
Copier with dual job feeder, compact sorter stapler, 3,500-sheet large capacity tray	205.8 kg (453.7 lb)
Copier with dual job feeder, floor type sorter stapler, 3,500-sheet large capacity tray	235.8 kg (519.8 lb)

Type 2

	Weight
Copier	163 kg (359.3 lb)
Copier with dual job feeder, floor type sorter stapler, 3,500-sheet large capacity tray	247.8 kg (546.3 lb)
Copier with recirculating document handler, finisher, 3,500-sheet large capacity tray	235 kg (518.1 lb)

Optional Equipment:

Dual job feeder
 Compact sorter stapler
 Floor type sorter stapler
 Recirculating document handler
 Finisher
 3,500-sheet large capacity tray
 Platen cover
 Copy tray

Dual Job Feeder

Original Size:	See page 19.
Original Weight:	See page 19.
Original Table Capacity:	See page 19.
Original Feed:	Automatic document feed (ADF) mode Automatic reverse document feed (ARDF) mode Semi-automatic document feed (SADF) mode Mixed sized mode Pasted original mode Preset mode
Original Set:	Face up, first sheet on top
Original Transport:	One flat belt
Power Source:	DC 24V, less than 2A (average) (from copier)
Power Consumption:	70 W
Weight:	13 kg (28.7 lb)
Dimensions (W x D x H):	680 x 508 x 116 mm (26.8" x 20.0" x 4.6")

Compact Sorter Stapler

Paper Size for Bins: See pages 37 and 38.

Paper Weight for Bins: See pages 37 and 38.

Bin Capacity: See pages 37 and 38.

Number of Bins: 20 bins + proof tray

Stapler Capacity: See page 40.

Stapling Position:

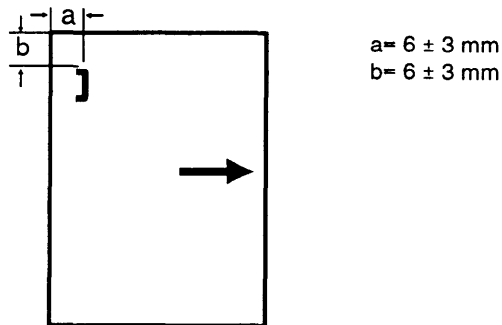

Staple Replenishment: Cartridge exchange (3,000 pieces/cartridge)

Power Source: DC 24V, 5V (from copier)

Power Consumption: 50 W

Dimensions (W x D x H) 420 x 600 x 690 mm (16.5" x 23.6" x 27.1")

Weight: 22 kg (48.4 lb)

Floor Type Sorter Stapler

Paper for Proof Tray: Size: Maximum: A3, 11" x 17"
 Minimum: A6 lengthwise, 5 1/2" x 8 1/2"
 Weight: 52 ~ 157 g/m², 14 ~ 42 lb

Paper for Bins: Sort mode: See page 37.
 Stack mode: See page 38.
 Staple mode: See page 39.

Paper Capacity: Proof tray: 250 sheets (80 g/m², 20 lb)
 Bins: Sort mode: See page 37.
 Stack mode: See page 38.
 Staple mode: See page 39.

Stapler Capacity: See page 40.

Staple Position:

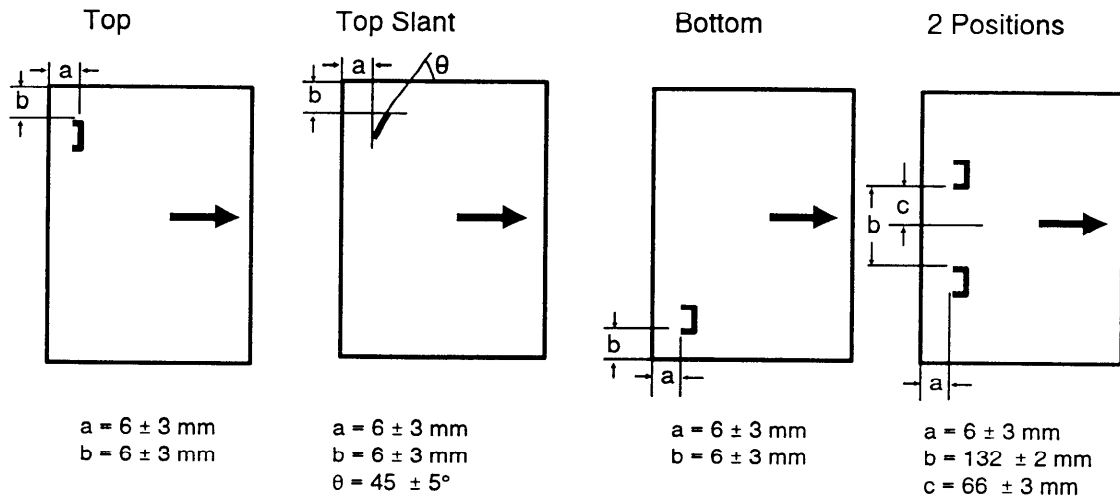

Staple Replenishment: Cartridge exchange (5,000 pieces/cartridge)

Power Source: DC 24V, DC 5V (from copier)

Power Consumption: Average: less than 80 W
 Maximum: in Sort mode: less than 100 W
 in Staple mode: less than 300 W

Weight: 52 kg (114.7 lb)

Dimensions (W x D x H) 566 x 583 x 978 mm (22.3" x 23.0" x 38.5")

Recirculating Document Handler

Original Size:	See page 31.
Original Weight:	See page 31.
Number of Originals to be Set:	See page 31.
Original Feed:	RDH mode (1 sided original mode, 2 sided original mode)
Original Set:	Face up, first sheet on top
Original Transport:	One flat belt
Power Source:	DC 24V (from copier)
Power Consumption:	70 W
Weight:	18 kg (39.7 lb)
Dimensions (W x D x H):	645 x 516 x 132 mm (25.4" x 20.3" x 5.2")

Finisher

Paper Size: Sort (default) mode: See page 37.
 *When the shift tray is not shifted, A6 can be stacked.
 Stack mode: See page 38.
 Staple mode: See page 40.

Paper Weight: Sort (default) mode: See page 37.
 Stack mode: See page 38.
 Staple mode: See page 40.

Paper Capacity: Sort (default) mode: See page 37.
 Stack mode: See page 38.
 Staple mode: See page 40.

Staple Position:

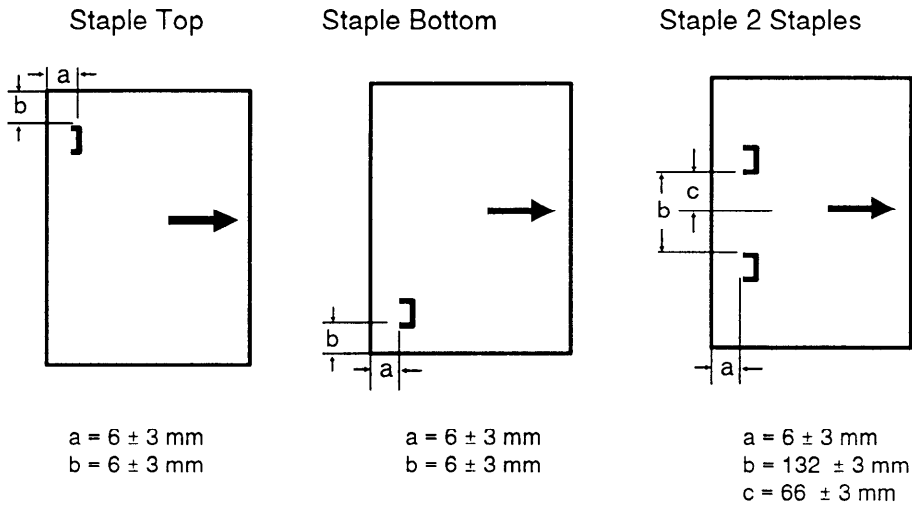

Staple Replenishment: Cartridge exchange (5,000 pieces/cartridge)

Power Source: DC 24V (from copier)

Power Consumption: 44.4 W

Weight: 34.2 kg (75.4 lb)

Dimensions (W x D x H) 671 x 514 x 950 mm (26.4" x 20.3" x 37.4")

SPECIFICATIONS

3,500-sheet Large Capacity Tray

Copy Paper Size:	See pages 64 and 65.
Copy Paper Weight:	64 ~ 105 g/m ² , 16 ~ 24 lb
Power Source:	DC 24V, 5V (from copier)
Power Consumption:	40 W
Dimensions (W x D x H):	403 x 529 x 608 mm (15.9" x 20.8" x 23.9")
Weight:	19.8 kg (43.7 lb)

Specifications are subject to change without notice.



MEMO



COMBINATION CHART

This combination chart shows which modes can be used together.

- means that these modes can be used together.
- means that one of these modes will be selected automatically.
- X means that these modes cannot be used together.

			Edit Image						Reduce/Enlarge				Duplex/Series Copies		
			1	2	3	4	5	6	7	8	9	10	11	12	13
Edit Image	1	Save Area	○	●	●	●	○	●	○	○	○	○	○	○	○
	2	Delete Area	●	○	●	●	○	●	○	○	○	○	○	○	○
	3	Erase Border	●	●	○	●	○	●	○	○	○	○	○	○	○
	4	Cent./Bord.	●	●	●	○	○	●	○	○	○	○	○	○	○
	5	Centering	○	○	○	●	○	●	○	○	○	○	○	○	X
	6	Margin Adj.	●	●	●	●	●	○	○	○	○	○	○	○	○
Reduce/Enlarge	7	Preset R/E	○	○	○	○	○	○	○	○	○	○	○	○	○
	8	Zoom	○	○	○	○	○	○	○	○	○	○	○	○	○
	9	Size Magnification	○	○	○	○	○	○	○	○	○	○	○	○	○
	10	Auto Reduce/Enlarge	○	○	○	○	○	○	○	○	○	○	○	○	○
Duplex/Series Copies	11	1Sided → 2 Sided	○	○	○	○	○	○	○	○	○	○	○	○	○
	12	2 Sided → 2 Sided	○	○	○	○	○	○	○	○	○	○	○	○	○
	13	Series Duplex (Single)	○	○	○	○	X	○	○	○	X	○	○	○	○
	14	Series Duplex (Multi)	○	○	○	○	X	○	○	○	X	○	○	○	○
	15	Book → 1 Sided	○	○	○	○	X	○	○	○	X	○	○	○	○
	16	2 Sided → 1 Sided	○	○	○	○	○	○	○	○	○	○	○	○	○
	17	Combine 2 Origs.	○	○	○	○	X	○	○	○	X	○	○	○	○
	18	Combine 4 Origs.	○	○	○	○	X	○	○	○	X	○	○	○	○
Finishing	19	Sort	○	○	○	○	○	○	○	○	○	○	○	○	○
	20	Stack	○	○	○	○	○	○	○	○	○	○	○	○	○
	21	Staple	○	○	○	○	○	○	○	○	○	○	○	○	○
	22	Not in above 3 modes (system A or B)	○	○	○	○	○	○	○	○	○	○	○	○	○
Cover/Slip Sheet	23	Front Cover	○	○	○	○	○	○	○	○	○	○	○	○	X
	24	Front/Back (Covers)	○	○	○	○	○	○	○	○	○	○	○	○	X
	25	Paper Designate	○	○	○	○	○	○	○	○	○	○	○	○	X
	26	OHP Slip Sheet	○	○	○	○	○	○	○	○	○	X	X	X	X
ETC.	27	Auto Paper Select	○	○	○	○	○	○	○	○	○	○	○	○	○
	28	Bypass Feed	○	○	X	X	X	X	○	○	○	X	X	X	X
	29	Interrupt mode	○	○	○	○	○	○	○	○	○	X	X	X	X
	30	Auto Image Density	○	○	○	○	○	○	○	○	○	○	○	○	○
	31	Preset mode	○	○	○	○	○	○	○	○	○	○	○	○	○
Special Orig.	32	Mixed Sizes	○	○	○	○	○	○	○	○	○	X	○	○	○
	33	Pasted Orig.	○	○	○	○	○	○	○	○	○	○	X	○	○

	Duplex/Series Copies					Finishing				Cover/Slip Sheet				ETC.					Special Orig.	
	14	15	16	17	18	19	20	21	22	23	24	25	26	27	28	29	30	31	32	33
1	○	○	○	○	○	○	○	○	○	○	○	○	○	○	○	●	○	○	○	○
2	○	○	○	○	○	○	○	○	○	○	○	○	○	○	○	●	○	○	○	○
3	○	○	○	○	○	○	○	○	○	○	○	○	○	○	×	●	○	○	○	○
4	○	○	○	○	○	○	○	○	○	○	○	○	○	○	×	●	○	○	○	○
5	×	×	○	×	×	○	○	○	○	○	○	○	○	○	×	●	○	○	○	○
6	○	○	○	○	○	○	○	○	○	○	○	○	○	○	×	●	○	○	○	○
7	○	○	○	○	○	○	○	○	○	○	○	○	○	○	○	●	○	○	○	○
8	○	○	○	○	○	○	○	○	○	○	○	○	○	○	○	●	○	○	○	○
9	○	○	○	○	○	○	○	○	○	○	○	○	○	○	○	●	○	○	○	○
10	●	●	○	●	●	○	○	○	○	○	○	○	○	●	●	●	○	○	○	○
11	●	●	●	●	●	○	○	○	○	○	○	○	×	○	×	●	○	○	×	○
12	●	●	●	●	●	○	○	○	○	○	○	○	×	○	×	●	○	○	○	×
13	●	●	●	●	●	○	○	○	○	×	×	×	×	×	×	●	○	○	○	○
14	●	●	●	●	●	○	○	○	○	×	×	×	×	×	×	●	○	○	○	○
15	●	●	●	●	●	○	○	○	○	×	×	×	○	×	×	●	○	○	○	○
16	●	●	●	●	●	○	○	○	○	×	×	×	×	○	○	●	○	○	○	×
17	●	●	●	●	●	○	○	○	○	×	×	×	○	×	○	●	○	○	×	×
18	●	●	●	●	●	○	○	○	○	×	×	×	×	×	×	●	○	○	×	×
19	○	○	○	○	○	●	○	●	○	○	○	○	●	○	×	●	○	○	○	○
20	○	○	○	○	○	●	●	●	●	●	●	●	○	×	●	○	○	○	○	○
21	○	○	○	○	○	○	●	○	○	○	○	○	○	○	×	●	○	○	○	×
22	○	○	○	○	○	●	●	●	○	○	○	○	○	○	○	●	○	○	○	○
23	×	×	×	×	×	○	×	○	○	○	○	○	○	×	○	●	○	○	×	×
24	×	×	×	×	×	○	×	○	○	○	○	○	○	×	○	●	○	○	×	×
25	×	×	×	×	×	○	×	○	○	○	○	○	○	×	○	●	○	○	×	○
26	×	○	×	○	×	×	×	×	○	○	○	○	○	×	○	●	○	○	×	○
27	●	●	○	●	●	○	○	○	○	○	○	○	○	○	○	○	○	○	○	○
28	×	×	○	○	×	×	×	×	○	○	○	○	○	○	○	○	○	○	○	○
29	×	○	○	○	×	×	×	×	○	×	×	×	×	○	○	○	○	○	○	○
30	○	○	○	○	○	○	○	○	○	○	○	○	○	○	○	○	○	○	○	○
31	○	○	○	○	○	○	○	○	○	○	○	○	○	○	○	×	○	○	○	×
32	○	○	○	×	×	○	○	○	○	×	×	×	×	○	○	●	○	○	○	○
33	○	○	×	×	×	○	○	×	○	×	×	○	○	○	○	○	○	×	○	○

A

Access To Copier, iv
 Accessing user tools, 14
 ADF mode, 21
 ARDF mode, 21
 Auto Image Density key, 35
 Auto off, 15
 Auto Paper Select, 17
 Auto Paper Select key, 35
 Auto Paper Select Priority, 17
 Auto Reduce/Enlarge key, 35
 Auto reset, 15
 Auto reset/Auto off
 Auto off, 15
 Auto reset, 15
 SADF Auto reset, 15
 Screen Saver, 15
 Auto Start mode, 42
 Auto Tray Switching, 17
 Autocount key, 44, 52, 55, 62
 Automatic Document Feed mode, 21
 Automatic Reverse Document Feed mode, 21

B

Back key, 59
 BASIC FUNCTIONS AND KEY TOPS, 35 - 42
 Belt, 79 - 80
 Book → 1 Sided key, 11, 50
 Bottom key, 39
 Bypass feed tray, 3, 71

C

Caution, i
 Cent./Bord. key, 10, 57
 Centering key, 10, 58
 Change fixed R/E, 17
 Change key, 18
 Change Modes key, 36
 CHANGING DEFAULT SETTINGS, 14 - 18
 CHANGING PAPER SIZE, 73 - 74
 Check Modes key, 36
 Check/Reset copy count, 18
 Clear Modes/Timer key, 6
 Clear/Stop key, 6
 Combine 2 Origs. key, 11, 52 - 54
 Combine 4 Origs. key, 11, 55
 Combine key, 11, 52
 Combine 2 Origs. key, 11, 52
 Combine 4 Origs. key, 11, 55
 combining 2 originals, 11
 combining 4 originals, 11
 Compact sorter stapler, 4, 86
 Contrast dial, 6

Copier, 78, 81 - 84
 Copier Environment, iii
 Copier Exterior, 3
 Copier Type, 2
 Copier type 1, 2
 Copier type 2, 2
 Copy tray, 3
 Cover sheet tray, 15
 Cover/Slip Sheet, 9, 60
 Front Cover key, 9, 60
 Front/Back key, 9, 61
 OHP Slip Sheet key, 9, 63
 Paper Designate key, 9, 62

D

DAILY MAINTENANCE, 78 - 80
 Default Setting, 16
 Delete Area key, 10, 57
 Delete key, 18
 DJF (dual job feeder), 19 - 30
 DO'S AND DON'TS, 77
 Dual job feeder, 4, 19 - 30, 79, 85
 Duplex key, 11, 44
 1 Sided → 2 Sided key, 11
 2 Sided → 2 Sided key, 11
 Duplex/Series Copies, 11, 44
 Combine key, 11, 52
 Duplex key, 11, 44
 Series Copies key, 11, 50
 Series Duplex key, 11, 48

E

Edit Image, 10, 56
 Editing/Centering key, 10, 56
 Margin Adj. key, 10, 59
 Editing/Centering key, 10, 56
 Cent./Bord. key, 10, 57
 Centering key, 10, 58
 Delete Area key, 10, 57
 Erase Border key, 10, 57
 Save Area key, 10, 56
 Enter key, 6
 Erase Border key, 10, 57
 Even key, 45, 53
 Exit key, 14
 Exposure glass, 3, 78

F

Feed-in Unit, 79 - 80
 Finisher, 5, 89
 Floor type sorter stapler, 4, 87
 from 1 sided originals to 2 sided copy, 11
 from 2 sided original to 1 sided copies, 11
 from 2 sided original to 2 sided copy, 11
 from book original to 1 sided copies, 11
 Front Cover key, 9, 60
 Front doors, 3
 Front key, 59
 Front/Back key, 9, 61
 Full Size (100%) key, 35
 FUNCTIONS ON OPERATION SCREENS, 43 - 63

G

Guidance display, 12 - 13
 Guidance key, 6, 12 - 13
 GUIDE TO COMPONENTS, 2 - 7

I

Image Density Level, 16
 INSTALLATION REQUIREMENTS, iii - iv
 Interrupt key, 6, 42

J

Job End Call, 16

K

key operator access code, 18
 Key Tops, 6

L

LOADING PAPER, 64 - 72

M

Main switch, 3
 Maintenance, 78 - 80
 Manual Image Density key, 35
 Manual Staple key, 41
 Margin Adj. key, 10, 59
 Maximum copy input number, 16
 Menu, 14
 Menu key, 14
 Misfed paper, 77
 Mixed Sized mode, 25
 Mixed Sizes key, 41
 Multi key, 11, 49

N

Next key, 16
 No key, 60 - 61, 63
 Number keys, 6
 Number keys key, 43, 55, 62

O

Odd key, 45, 54
 OHP Slip Sheet key, 9, 63
 Operation panel, 3, 6
 Key Tops, 6
 Touch Panel Display, 7
 Operation screens, 43 - 63
 Optional 3,500-sheet Large Capacity Tray, 70
 Original Count Display, 17
 Originals for DJF, 19
 Originals for RDH, 31

P

Panel beeper, 16
 Paper, 64 - 72
 Paper Designate key, 9, 62
 Paper for copier type 1, 64
 Paper for copier type 2, 65
 Paper for Sort mode, 37
 Paper for Stack mode, 38
 Paper for Staple mode, 40
 Paper Storage, v
 Paper Tray Display in APS mode, 17
 Paper Tray Priority, 17
 Pasted Orig. key, 41
 Pasted Original mode, 27 - 28
 Platen cover, 3, 78
 Power Connection, iv
 Preset key, 41
 Preset mode, 29 - 30
 Preset R/E key, 10, 43
 Presetting Originals in DJF During Copy Run, 29 - 30
 Prev. key, 16, 36
 Program key, 6, 42

R

RDH (recirculating document handler), 31 - 33
 Recirculating document handler, 5, 31 - 33, 80, 88
 Reduce Enlarge
 Preset R/E key, 43
 Reduce/Enlarge, 10, 43
 Preset R/E key, 10, 43
 Size Mag. key, 10, 43
 Zoom key, 10, 43
 Register key, 18
 Reset data for User Codes, 18
 Reset User Codes/Counters, 18

S

SADF Auto reset, 15
 SADF mode, 23
 SAFETY INFORMATION, i - ii
 Save Area key, 10, 56
 Screen Saver, 15
 Seeking guidance, 12 - 13
 Select ARDF/RDH modes
 Auto Paper Select, 17

INDEX

- Original Count Display, 17
 - Thin Paper mode, 17
 - Select special tray
 - Tray Display for Cover Sheet, 15
 - Tray Display for Slip Sheet, 15
 - Tray for Cover Sheet, 15
 - Tray for Slip Sheet, 15
 - Select Tray key, 35
 - Semi-Automatic Document Feed mode, 23
 - Series Copies key, 11, 50
 - 2 Sided → 1 Sided key, 11, 51
 - Book → 1 Sided key, 11, 50
 - Series Duplex key, 11, 48
 - Multi key, 11
 - Single key, 11
 - Set date/time, 16
 - Set operation modes
 - Default Setting, 16
 - Image Density Level, 16
 - Job End Call, 16
 - Maximum copy input number, 16
 - Panel beeper, 16
 - Touch Panel in Waiting Mode, 16
 - Set standard tray display
 - Auto Paper Select Priority, 17
 - Auto Tray Switching, 17
 - Paper Tray Display in APS mode, 17
 - Paper Tray Priority, 17
 - Set User Code(s), 18
 - Change key, 18
 - Delete key, 18
 - Register key, 18
 - Setting A Pasted Original in DJF, 27 - 28
 - Setting A Stack Of Originals in DJF, 21 - 22
 - Setting Different Sized Originals in DJF, 25 - 26
 - Setting One Original At A Time in DJF, 23 - 24
 - SETTING ORIGINALS IN RDH, 31 - 33
 - SETTING ORIGINALS IN THE DUAL JOB FEEDER, 19 - 30
 - Setting originals in the Staple mode, 39
 - SETTING ORIGINALS ON THE EXPOSURE GLASS, 34
 - Single key, 11, 48
 - Size Mag. key, 10, 43
 - Slip sheet tray, 15
 - Sort key, 37
 - Special Orig. key, 41
 - Specifications, 81 - 90
 - Stack key, 38
 - Staple 2 Staples key, 39
 - Staple Bottom key, 39
 - Staple key, 39
 - Staple Top key, 39
 - Stapling Copies, 39 - 40
 - Stapling position, 39
 - Start key, 6
 - STORAGE OF SUPPLIES, v
 - System A, 4
 - Compact sorter stapler, 4
 - Dual job feeder, 4
 - System B, 4
 - Dual job feeder, 4
 - Floor type sorter stapler, 4
 - System C, 5
 - Finisher, 5
 - Recirculating document handler, 5
 - System Overview, 4 - 5
- ## T
- Tandem paper tray, 3, 67 - 68
 - Thin Paper mode, 17
 - Toner, 77
 - Toner Storage, v
 - Top key, 39
 - Top Slant key, 39
 - Touch Panel Display, 7, 78
 - Touch Panel in Waiting Mode, 16
 - Tray Display for Cover Sheet, 15
 - Tray Display for Slip Sheet, 15
 - Tray for Cover Sheet, 15
 - Tray for Slip Sheet, 15
 - Troubleshooting guide, 75
- ## U
- User Code mode, 18
 - USER REMARKS, 76
 - User Tools, 14 - 18
 - User Tools for User Code Mode, 18
- ## W
- WARNING, i
 - Warning when adding toner, 77
 - Warning when removing misfed paper, 77
 - Weekly Timer, 16
 - WHAT TO DO WHEN THINGS GO WRONG, 75
 - WHAT YOU CAN DO WITH THIS COPIER, 8 - 11
- ## Y
- Yes key, 60 - 61, 63
- ## Z
- Zoom key, 10, 43
- ## etc.
- +– key, 43
 - 1 Sided → 2 Sided key, 11, 44 - 46
 - 1,500-sheet Large Capacity Tray, 69
 - 100% (Full Size) key, 35
 - 2 Sided → 1 Sided key, 11, 51
 - 2 Sided → 2 Sided key, 11, 47
 - 2 Staples key, 39
 - 3,500-sheet Large Capacity Tray, 90
 - 550-sheet paper tray, 3, 66

In accordance with ISO Standard 7001, this machine uses the following symbols for the main switch:

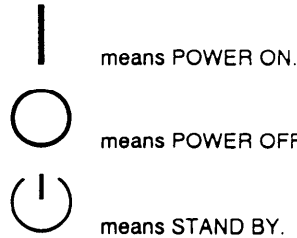

Note to users in the United States of America

Warning: This equipment has been tested and found to comply with the limits for a Class A digital device, pursuant to Part 15 of the FCC Rules. These limits are designed to provide reasonable protection against harmful interference when the equipment is operated in a commercial environment. This equipment generates, uses, and can radiate radio frequency energy and, if not installed and used in accordance with the instruction manual, may cause harmful interference to radio communications. Operation of this equipment in a residential area is likely to cause harmful interference in which case the user will be required to correct the interference at his own expense.

Note to users in Canada

Warning: This digital Apparatus does not exceed the Class A limits for Radio Frequency noise from Digital Apparatus set out in the Radio Interference Regulations of the Canadian Department of Communications.

Remarque concernant les utilisateurs au Canada

Avertissement: Le présent appareil numérique n'émet pas de bruits radioélectriques dépassant les limites applicables aux appareils numériques de la classe A prescrites dans le Règlement sur le brouillage radioélectrique édicté par le ministère des Communications du Canada.

Overseas Affiliates

U.S.A.

RICOH CORPORATION
5 Dedrick Place
West Caldwell, New Jersey 07006
(TEL) 201-882-2000

NORTHEAST REGION
5 Dedrick Place
West Caldwell, New Jersey 07006
(TEL) 201-882-2010

SOUTHEAST REGION
3567 Parkway Lane
Suite 150
Norcross, GA 30092
(TEL) 404-446-3533

MIDWEST REGION
4415 West Harrison Street
Suite 201
Hillside, IL 60162
(TEL) 708-449-1117

SOUTHWEST REGION
125 East John Carpenter Freeway
Suite 700
Irving, TX 75062
(TEL) 214-556-0965

WESTERN REGION
1231 Warner Avenue
Tustin, CA 92680
(TEL) 714-259-1310

NEW YORK BRANCH
1133 Avenue of the Americas
Suite 3100
New York, N.Y. 10036
(TEL) 212-575-0930

**WASHINGTON D.C.
FEDERAL GOVERNMENT BRANCH**
1700 N. Moore Street
Suite 1030
Arlington, VA 22209
(TEL) 703-528-0040

Netherlands
RICOH EUROPE B.V.
Groenelaan 3 P.O. Box 114
1180 AC - Amstelveen Holland
(TEL) 020-547-4111

United Kingdom
RICOH U.K. LTD.
Ricoh House
1 Plane Tree Crescent, Feltham,
Middlesex, TW13 7HG
(TEL) 081-751-6611

Germany

RICOH DEUTSCHLAND GMBH
Mergenthalerallee 38-40,
6236 Eschborn
(TEL) (06196) 906-0

France

RICOH FRANCE S.A.
192 Avenue Charles de Gaulle,
92200 Neuilly-sur-Seine
(TEL) 01-4745-4510

Spain

RICOH ESPAÑA S.A.
Guitard, 45
08014 Barcelona
(TEL) 490-09-60

Italy

RICOH ITALIA S.p.A.
Via della Metallurgia, 12
(zona Basson) - 37139 VERONA
(TEL) 045-851 00 44

Hong Kong

RICOH BUSINESS MACHINES, LTD.
23/F., China Overseas Building,
139, Hennessy Road,
Wan Chai, Hong Kong
(TEL) 862-2888

RICOH COMPANY, LTD.

Address : 15-1, 1 chome, Minami-Aoyama,
Minato-ku, Tokyo

Telephone : Tokyo 3479-3111

Telex : 242-5415, 242-5418

Cable : "RICOHBLDG TOKYO"

Free Manuals Download Website

<http://myh66.com>

<http://usermanuals.us>

<http://www.somanuals.com>

<http://www.4manuals.cc>

<http://www.manual-lib.com>

<http://www.404manual.com>

<http://www.luxmanual.com>

<http://aubethermostatmanual.com>

Golf course search by state

<http://golfingnear.com>

Email search by domain

<http://emailbydomain.com>

Auto manuals search

<http://auto.somanuals.com>

TV manuals search

<http://tv.somanuals.com>