



VR500CS-BT

Owner's Manual

**AM/FM Receiver, with CD, CDR, CD-RW, and MP3 Playback, USB, SD/MMC input with Electronic Anti-Shock (ESP) & Detachable Face, Bluetooth Connection with Dial In-Out Function
Up to 1GB storage size of USB flashdisk and SD/MMC media storage.**

Welcome!

Dear Customer,

CONGRATULATIONS. The VR500CS-BT MP3/CD Player with AM/FM Receiver, USB Port and SD Card Slot, Electronic Anti-Shock (ESP) & Fold-down Detachable Face, when used as described, will give you years of dependable service in your car, truck, RV, or mini-van. We have taken numerous measures in quality control to ensure that your product arrives in top condition and will perform to your satisfaction. In the rare event that your VR500CS-BT MP3/CD Player with AM/FM Receiver, USB Port and SD Card Slot, Electronic Anti-Shock (ESP) & Fold-down Detachable Face, contains a damaged or missing item, does not perform as specified, requires warranty service, or you have an installation problem, **DO NOT RETURN THIS PRODUCT TO THE STORE. PLEASE CALL OUR TOLL FREE NUMBER FROM THE U.S.A. AND CANADA 1-800-445-1797** and ask to speak with a member of our technical service team; or submit your questions by e-mail to customerservice@vr-3.com and a member of our technical service team will respond by e-mail to your questions. Our in-house technical service team will expedite delivery of your part, advise you on installation, or help troubleshoot a problem with you. If your product needs warranty service, our technical service team representative will help you obtain the fastest remedy possible under the warranty.

CONTENTS

Contents	1
Precautions.....	2
Care of Discs	2
Flash Memory	2
Notes on Installation.....	3
Tools & Supplies	3
Before You Install.....	4
Installation (DIN Front Mount).....	5
Installation (Vehicle's Brackets).....	6
Microphone.....	7
Wiring Connections	8
Location of the Controls	9
Remote Control	10
Basic Operation	11
Bluetooth	12-13
Radio Operation.....	14
RDS Operation.....	14-15
CD Operation.....	15-16
MP3/WMA Operation (CD)	16-17
USB/SD Card Operation.....	17-18
Search Modes for MP3 & WMA Files.....	18
AUX IN, RCA, & Subwoofer Control.....	19
Specifications	20
Warranty.....	21

Precautions

- This unit will only play the following discs.
- This unit does not play files that have Digital Rights Management(DRM).
- If you have files that have Digital Rights Management(DRM) you should consult with the vendor that you purchased files from for instructions on proper use.

Type of disc	Label on the disc	Recorded material	Size of disc
CD, MP3, & WMA		Audio only	12 cm

- Do not attempt to modify the unit.
- Modifying the unit will void the warranty.
- Stop the vehicle before carrying out any operation that could interfere with your driving.
- Do not operate in extremely high or low temperatures. The temperature inside the vehicle should be between 32° F (0° C) and 100° F (37° C) before turning on your unit.

CARE OF DISCS

- Handle the disc by its edge to keep the disc clean. Do not touch the disc's surface.
- Do not use CDs with labels or stickers attached. The label may leave a sticky residue when it begins to peel.



- Do not use a CD with paste or ink residue on it.
- Clean the discs with an optional cleaning cloth. Wipe each disc from the center out.



FLASH MEMORY

The VR500CS-BT supports USB Flash Memory, Secure Digital Card (SD) and Multi Media Card (MMC) of up to 1GB of memory. We recommend you format your Flash Drive/SD Card in FAT32 format before saving any files. If you experience any compatibility problems, we recommend that you contact the manufacturer of the Flash Drive/SD Card/Multi Media Card.

Notes On Installation

- **Disconnect negative battery terminal before starting installation. Consult the vehicle's owner's manual for proper instruction.**
- **The unit is designed for a 12Volt DC negative ground operation system only. Before installing the unit, confirm that your vehicle is a 12Volt DC negative ground system.**
- **Be sure to connect the color coded leads according to the diagram. Incorrect connections may cause the unit to malfunction or damage the vehicle's electrical system.**
- **Be sure to connect the negative (-) speaker leads to the negative (-) speaker terminal. Never connect negative (-) speaker leads to chassis ground.**
- **The unit is only designed for use with 4 speakers. Do not combine output for use with 2 speakers. Do not ground negative speaker leads to the chassis ground.**
- **Make sure all the connections are completely correct before turning on your unit.**
- **When replacing the fuse(s), the replacement must be of the same amperage as shown on the fuse holder.**
- **Do not block vents or heater panels. Blocking them will cause heat to build up inside and may result in fire.**
- **After completing the installation and before operating the unit, reconnect the battery. Then press the (RES) button with a pointed object, such as a ball-point pen to set the unit to its initial status.**

Tools For Installation

- The 2 removal keys are supplied for removing the old unit and replacing with the "VR500CS-BT".

The following tools and supplies may also be needed for the installation:

TOOLS

- Phillips Screw-drivers
- Wire Stripper
- Wire Cutter
- Hammer
- Pencil
- Electrical Tape
- Electric Drill

SUPPLIES

- Machine Screws
- Crimp Connectors
- 14 Gauge Wire for Power Connections
- 14-16 Gauge Speaker Wires

The above are NOT INCLUDED with the VR500CS-BT and must be purchased separately.

Before You Install

Automotive audio equipment installations can be challenging at times, even to the most experienced of installation technicians.

If you are not confident working with electrical wiring, removing and re-installing interior panels, carpeting, dashboards or other components of your vehicle, please call your dealer in order to have the unit professionally installed.

IMPORTANT!

BEFORE THE FINAL INSTALLATION OF THE HEAD UNIT, CONNECT THE WIRING TEMPORARILY, MAKING SURE THE UNIT AND THE SYSTEM WORK PROPERLY.

1. Remove the Old Unit from the Dashboard

A. Remove the outer trim frame.

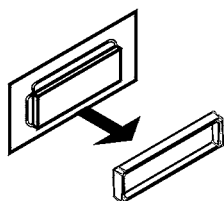

DIN Front Mount Style

B. Insert the keys supplied with the old unit into both sides of the old unit as shown in figure below until they click. Push keys apart and pull to remove the old unit from the dashboard.

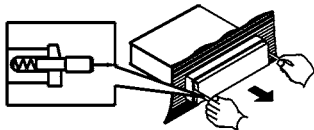

DO NOT DISCONNECT WIRES AT THIS TIME!

2. Mark Polarity of the Speaker Wires

Marking the polarity of the speaker wires will make it easier to connect the existing speakers to the Head Unit.

Consult wiring diagram of existing head unit before disconnecting any wires. If a wiring diagram is not available contact the manufacturer.

- While the old unit is playing, disconnect the wires from one speaker.
- Take a length of masking tape and fold it around the wire so it forms a flag.
- On the masking tape mark the polarity of the speaker wires (+ & -), as well as left or right, and front or rear.
- Double check that you marked the first speaker correctly by checking that the speaker wires are the same at the head unit.
- Repeat this procedure for all of the speakers.
- Mark the power, ground, and any other wires also.

Installation

DIN FRONT-MOUNT (Method A)

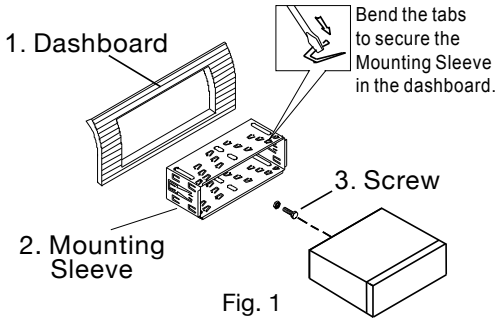

After inserting the Mounting Sleeve into the dashboard, select tabs on top, bottom, and sides, then bend them to secure the mounting sleeve in the dashboard. (Fig. 1)

Follow the diagram in Fig. 2 for installing the rear mounting strap to the head unit. The rear mounting strap will help keep the head unit from moving around inside the dashboard.

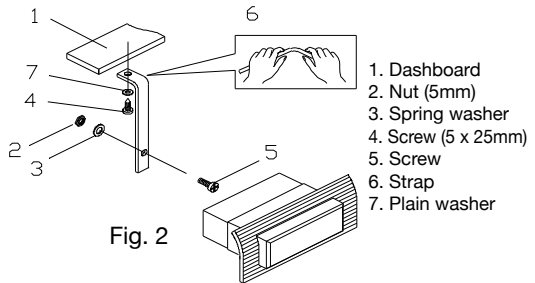

Insert fingers into the groove in the front of frame to remove it.

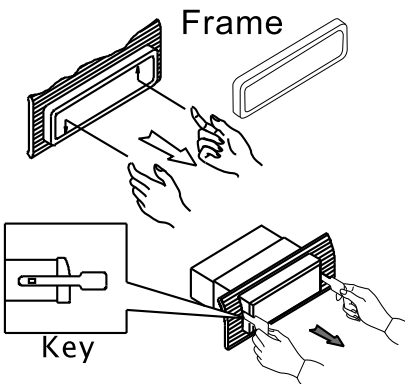

Insert the keys supplied with the unit in the grooves on both sides. The unit can be installed or removed from the dashboard using these keys. (Fig. 3)

IMPORTANT

Remove the transport CD Stopper (2 screws) before use.

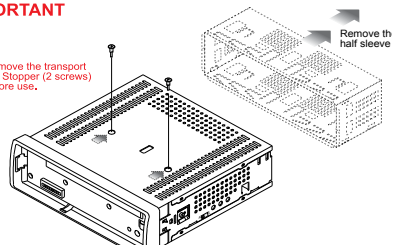

Remove the two transport screws from the top of the unit before installing.

Installation

DIN REAR-MOUNT (Method B)

Installation using the screw holes on both sides of the unit.

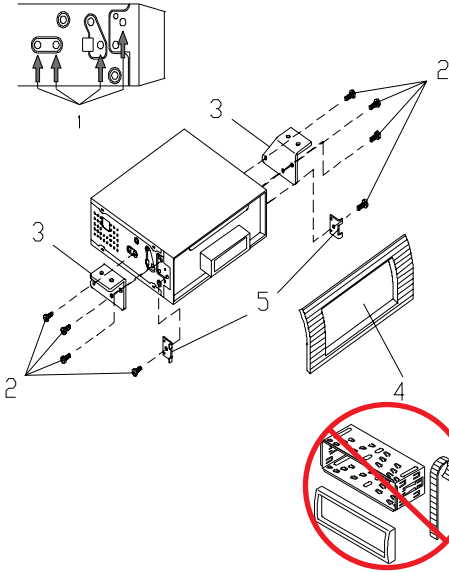

PARTS



- 2 Keys
- 1 Hex Nut
- 1 Mounting Sleeve (not shown)
- 2 Lock Washers
- 1 Sheet Metal Screw
- 1 Metal Support Strap

- 2 Flat Washers
- 1 Mounting Bolt
- 1 Faceplate Case (not shown)
- 1 1/8" Stereo Cable
- 1 Remote Control
- 1 External Microphone

Installation

MICROPHONES

The VR500CS-BT has the ability to use two microphones. One microphone is built-in, the other is a remote microphone.

Built-In Microphone

The built-in microphone is located on the front right side of the unit. There is no setup required for this microphone and it is tuned to pick-up the voices of the front and rear seat passengers.

Built-In Microphone (not visible)



Microphone Jack

Microphone Jack

The supplied microphone shall be used to ensure the sound quality of the driver's voice.

Installation

The microphone jack is located on the front of the unit. Insert the plug of the supplied microphone into the microphone jack. Route the microphone and wire to the driver's side sun visor, rear view mirror, or other area near the driver. Make sure that the microphone and wire do not interfere with the safe operation of the vehicle.

Setting the Microphone Volume

1. Press the "PHONE" button.
2. Press and hold the Volume Knob until you see "OUT NUM" on the LCD
3. Press the Volume Knob to cycle through the menu to "TEL".
4. Rotate the Volume Knob to set the volume of the microphone.



GIVE US A CALL, WE'LL HELP YOU INSTALL.

PLEASE DO NOT RETURN PRODUCT TO STORE.

Visit us on the WEB

www.vr-3.com

For Information and Technical Assistance,
Call Toll-Free in U.S.A. and Canada.

1-800-445-1797

Wiring Connections

Make sure you have good chassis ground. A good ground connection will eliminate most electrical noise problems. A good chassis ground requires a tight connection to the vehicle's metal chassis. The area around the ground connection should be clean, bare metal without rust, paint, plastic, dust, or dirt for a good electrical connection.

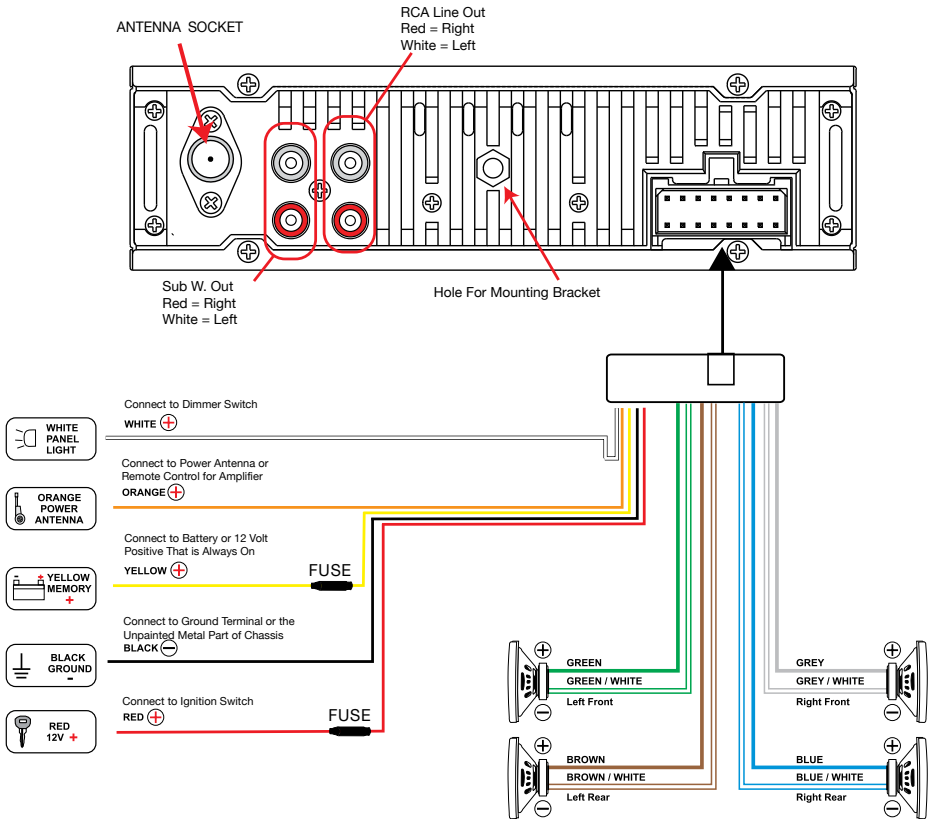

Speaker Wiring Notes

Follow the above wiring diagram to install the head unit with new or existing speakers.

- This unit is designed for use with four (4) speakers with an impedance between 4 Ohms to 8 Ohms.
- An impedance load of less than 4 Ohms could damage the unit.

- Never bridge or combine the speaker wire outputs. When not using four speakers, use electrical tape to tape the ends of the unused speaker outputs to prevent a short circuit.
- Never ground the negative speaker terminals to chassis ground.

Location Of The Controls

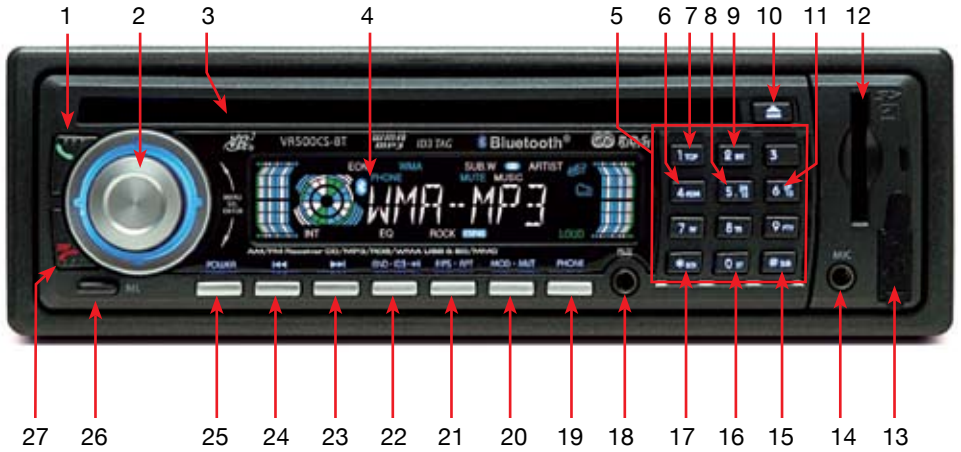

- | | |
|---------------------------------|--|
| 1. Answer/ Green Phone | 17. Scan/Star Sign |
| 2. Volume/SEL/Enter | 18. Auxiliary Input |
| 3. Disc Slot | 19. PHONE |
| 4. Liquid Crystal Display (LCD) | 20. Mode/Mute |
| 5. 0-9, #, & * Key Pad buttons | 21. FPS/Repeat |
| 6. Random / No. 4 | 22. BND•ID3 |
| 7. No.1 / Top | 23. Next Track/Fast Forward |
| 8. No.5 / Down 10 | 24. Previous Track/Fast Reverse |
| 9. Intro/No. 2 | 25. Power |
| 10. Eject | 26. Remove Faceplate |
| 11. No. 6 / UP 10 | 27. Hang up/ Red Phone |
| 12. SD/MMC Card Slot | 28. Americas/Europeon Frequency Switch |
| 13. USB Port with Cover | 29. Reset Switch |
| 14. Microphone Jack | 30. LED Power indicator |
| 15. Subwoofer/Pound Sign | |
| 16. Stereo/No. 0 | |

When the faceplate is removed the LED Power Indicator will flash ON & OFF

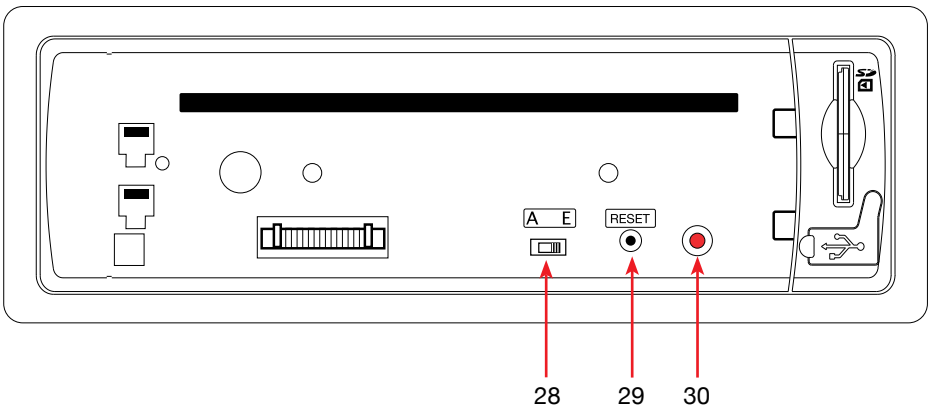

Remote Control

Operating the Remote Control

Aim at the front panel of the CD Receiver.

The maximum operating distance is about 6M.

Make sure that the signal path is not obstructed.

Do not drop or throw the remote control.

Do not expose the remote control to direct sunlight or place next to a heating unit or other heat source.

1. Power On/Off
2. Volume Up
3. Select/Menu/Enter
4. Volume Down
5. Intro/No. 2
6. No. 1/Top
7. No. 5/Down 10
8. No. 4/Random
9. No. 8/TA Control
10. No. 7/AF
11. No. 0/Stereo
12. Star Symbol/Scan
13. PHONE
14. Green Phone Icon
15. No. 3
16. Next Track/Fast Forward
17. No. 6/UP 10
18. Previous/Fast Reverse
19. No. 9/PTY
20. Mode/Mute
21. Pound Symbol/Subwoofer
22. Band/ID3/Play/Pause
23. Display/Red Phone Icon
24. F/PS/Repeat

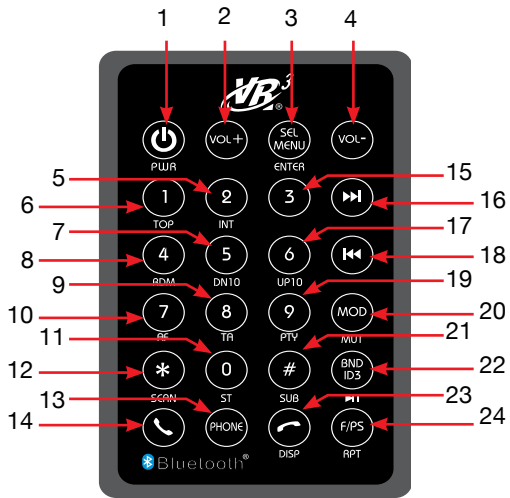

Replacing the Battery

The VR500CS-BT Remote Control comes with a CR-2025 Lithium Battery included.

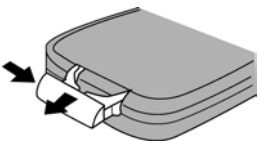

Remove the Battery Holder from the back of the Remote Control.

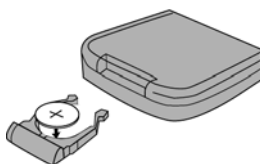

Insert a CR-2025 Lithium battery.

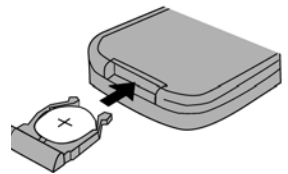

Insert the Battery Holder into the back of the Remote Control.

Basic Operation

1. Tuning the Unit On / Off

Press any Button to turn the unit on, the display will show a message WELCOME to indicate it is ready for use. Press the POWER button for 2 seconds to turn the unit off.

2. Mode Selection

Press the BAND Button to select Radio Mode. Press and hold the MOD/MUT Button to cycle the Play Mode between AUX, RADIO and CD PLAY.

Note: USB mode or memory card mode will only be displayed when a USB flash memory or SD Card is inserted.

3. Loudness Control (head unit only)

Press and hold the Volume Knob for 2 seconds, then press the Volume Knob repeatedly to cycle through to "LOUD OFF". Then rotate the Volume Knob to turn to "LOUD ON" for loudness to take effect.

4. Subwoofer Control

Press SUB/# Button on the front panel, or press the #/SUB Button on the remote control to turn the subwoofer ON or OFF.

The unit must have an external amplifier installed to drive the subwoofer.

5. Mute Control

Press and hold the MOD/MUT Button to mute the radio. Press and hold again to cancel. Note: If you press this button but do not hold it, it will change to another play mode.

6. Volume

Use the Volume Knob to adjust the volume level. The display shows VOL 00 to VOL 47. The larger the number, the higher the volume level.

7. Bass

Press the Volume Knob until the display shows "BAS". Use the Volume Knob to adjust. When DSP is ON, bass control is not

available.

8. Treble

Press Volume Knob until the display shows "TRE". Use the Volume Knob to adjust. When DSP is ON, treble control is not available.

9. Balance

Press Volume Knob four times and the display shows "BAL", then use the Volume Knob to adjust the balance between the left & right speakers.

10. Fader

Press Volume Knob five times and the display shows "FAD", then use the Volume Knob to adjust the balance between the front & rear speakers.

11. Clock

The time clock can be set anytime when the power is on. Press the DISP Button and then press and hold DISP Button for 3 seconds, the time will blink on the display.

1. Press the VOL + Button to adjust the hour.
2. Press the VOL - Button to adjust the minute.
3. Press the DISP Button again or leave the unit idle for new setting to effect. Press the DISP Button anytime to view the time clock display.

12. Preset Beep Sound Off

1. Press the Volume Knob for 2 Seconds. The display will show "DSP OFF", then press the Volume Knob repeatedly until the display shows "BEEP OFF". Use the Volume Knob to select "BEEP OFF" or "BEEP ON", then leave the unit idle for setting to take effect.

13. Preset Equalizer Function

Press and hold the Volume Knob for 2 seconds, the display will show "EQ OFF". Press the Volume Knob to choose the EQ sound effect desired.

Bluetooth Connection

Before Connecting

Turn the VR500CS-BT ON, then turn your cell phone's Bluetooth Function ON.

1. Pairing

1. Press the "PHONE" button.
2. Press and hold the Volume Knob until you see "DISP OFF",
3. Press the Volume Knob repeatedly to cycle through to "PAIRING".
4. Press and hold the Volume Knob until the word "PAIRING" blinks on the display,
5. Run the Bluetooth search and connect function on your cell phone.
6. VR500CS-BT will be shown on your cell phone's list of available connections. Select the VR500CS-BT to connect the cell phone with the VR500CS-BT.

When you are asked for a connection password, please input "0000" in your cellphone to finish the pairing.

The Bluetooth icon and the word "PHONE" will be shown on the VR500CS-BT's LCD indicating that the Bluetooth function is active and ready to use.

2. Ring Volume

1. Press the "PHONE" Button.
2. Press and hold the Volume Knob until you see "FIND NUM".
3. Then press the Volume Knob to cycle through until "RING" appears. You can adjust the incoming call volume from "0"- "47". The radio will ring in the midst of song playing if there is any incoming phone call.

3. Telephone Volume

1. Press the "PHONE" Button.
2. Press and hold the Volume Knob until you see "FIND NUM".
3. Then press the Volume Knob to cycle through until "TEL" appears. You can adjust the telephone volume from "0"- "47". The larger the number, the louder the speaker volume during the call.

4. Incoming Call Display

When there is an incoming call the LCD Display will blink the incoming number for your

quick reference.

5. Answering a Call

When there is an incoming phone call, press the GREEN PHONE Button on the front panel or on the remote control to receive the call through your car radio.

6. Ending a Call

When you have finished or wish to ignore a call, press the Red "PHONE" Button either on the Faceplate or on the remote control to hang up.

7. Dialing with the Faceplate

When you want to dial a call from the front panel of the radio, press the "PHONE" Button on the front panel. Press Buttons 0-9 to dial the telephone number you wish to call. Press the Green PHONE Button to activate the call.

8. Dialing on the Remote Control

To make a call dialing with the remote control, press the "PHONE" Button on the remote. Press Buttons 1-0 on the remote to dial the telephone number you wish to call. Press the Green PHONE Button to activate the call.

9. Recently Dialed Numbers

After connecting with cell phone;

1. Press the "PHONE" button.
2. Press and hold the Volume Knob until you see "OUT NUM".
3. Press and hold the Volume Knob and the display will show the most recently dialed number.
4. Rotate the Volume Knob to choose among the 10 recently dialed numbers.
5. Press the Green "Phone" button to dial the displayed number.

Alternative:

1. Press the "PHONE" button;
2. Press the Green Phone button;
3. The most recent dialed number will be shown. Rotate the volume knob to view the recent 10 dialed numbers. Press Green Phone button to make call.

Bluetooth Connection

10. Recently Received Calls

After connecting with cell phone;

1. Press the "PHONE" button.
2. Press and hold the Volume Knob until you see "OUT NUM", then press the Volume Knob until the display shows "IN NUM".
3. Press and hold the Volume Knob and the display will show the most recent received call.
4. Rotate the Volume Knob to choose among the 10 recent received numbers.
5. Press the Green "Phone" button to dial the displayed number.

11. Speed Dial

You can save up to 10 phone numbers in memory for Speed Dialing.

1. Press the "PHONE" button.
2. Press and hold the Volume Knob until you see "OUT NUM".
3. Next press the Volume Knob to cycle through to "ADD NUM".
4. Press and hold the Volume Knob and the display will show "NAME **".
5. Use the Volume Knob to choose letters to compose name of up to 16 characters. Press and hold Volume Knob to confirm.
6. The display will show "NUMBER **". Use the number buttons on the faceplate or the remote control to enter a telephone number of up to 32 digits.

12. Speed Dialing a Phone Number

1. Press the "PHONE" button.
2. Press and hold the Volume Knob until you see "OUT NUM".
3. Then press the Volume Knob to cycle through to "FIND NUM".
4. Press and hold the Volume Knob and the display will show your saved name.
5. Use the Volume Knob to choose the name and press the Green "PHONE" Button to call someone easily.

13. Disconnecting the Phone

Press and hold the Volume Knob until you see "OUT NUM", then press the Volume Knob to cycle through to "DIS CONN".

Press and hold to disconnect the current phone call so that you can connect with another call.

14. Ringtones

1. Press the "PHONE" button.
2. Press and hold the Volume Knob until you see "OUT NUM".
3. Then press the Volume Knob to cycle through to "MELODY".
4. Press and hold the Volume Knob and the display will show MELODY 1.
5. Rotate the Volume Knob to choose from MELODY 1 to 6 as different incoming music tone in the car radio.
6. Press and hold the Volume Knob to confirm after your desired Ringtone is displayed.

15. Auto Re-Connect

This unit has an "Auto Re-Connect Function". In case the connected cellphone is out of range (e.g. the user leaves the car for lunch), the unit will automatically connect with the cell phone upon returning so that you do not have to re-set the connection.

16. BT-PLAY Stereo Transfer

The BT-PLAY function is for listening to music on the VR500CS-BT via Bluetooth from your cell phone. Play the music in the cellphone, then choose the option of "play via bluetooth" in the cellphone.

Then press the MODE button in the radio until the display shows "BT-PLAY". Note: BT-PLAY mode will only be displayed when you have activated the Bluetooth function on your cellphone. You can now listen to the music from the cellphone through the car speakers.

NOTE: It's highly recommended that BT-PLAY mode should not be used simultaneously with PHONE mode. Please quit BT-PLAY mode before attempting to make a phone call, unexpected results may occur, depending on different cellphone models.

Radio Operation

1. Choose Radio Band

Press the BND•ID3 Button anytime to access the radio function.

The unit comes with five bands - three FM (FM1, FM2, and FM3) and two AM (AM1 and AM2) Band selects. Each of the five bands can store up to six preset stations, for a total of 30 preset memory stations.

NOTE: To change the receiving range from USA to Europe, remove the faceplate and move the switch marked "A-E" to the appropriate region.

2. Radio Tune / Seek Function

In Radio Mode, press and hold the >>| or |<< Button, the word MANUAL will be shown on the LCD. Now you will be able to tune the radio frequency by .10 with each press of |<< or >>| button.

To Scan automatically for the next strongest signal press and hold the */SCN button. The receiver will start searching for the next strongest signal. When the next strongest signal is found the LCD will flash the frequency ON and OFF. To remain tuned to a frequency press the */SCN button again.

3. Mono/Stereo Reception Control

In FM radio mode, press the 0/ST button on the front panel or on the remote control to toggle between mono reception or stereo reception. The display will show "MONO" or "STEREO".

Improvement of reception of distant stations can be done by selecting "MONO" operation which may cut down some reception noise.

4. Save Your Preset Stations

There are six numbered preset buttons which can store and recall stations for each band. While listening to a radio station, press and hold one of the buttons numbered 1-6 until you hear a beep, the BEEP function must be ON. That button is now the pre-set button for that station.

5. Automatic Store/Preset Scan

A. Automatic Scan & Store

While listening to the FM Radio, press and hold the F/PS Button for more than 3 seconds. The receiver will automatically scan and save stations to one of the FM Bands. While listening to the AM Radio, press and hold the F/PS Button for more than 3 seconds. The receiver will automatically scan and save stations to one of the AM Bands.

B. Reset Automatic Scan & Store

Press and hold the F/PS button for 3 seconds and the receiver will scan the radio stations in your area, then save them over the current pre-sets.

C. Scan Saved Stations

Press the F/PS Button once to scan all stations saved. In the FM Mode, all 3 FM Bands will be scanned. In the AM Mode both of the AM Bands will be scanned.

RDS Operation

RDS stands for Radio Data System and is used to send small amounts of digital information via conventional FM radio broadcasts. The RDS system standardizes several types of information transmitted such as time, track, artist information, and station identification.

RDS-EON Control

This unit is equipped with the latest technology of EON control (Enhanced Other Networks), this allows the radio to monitor other radio stations for traffic broadcasts, so when you are listening to Radio or CD, and there is a travel announcement from a nearby local station, the radio will tune to the frequency of that local radio station. Then it will receive the station, turn up the volume, or interrupt the playback of the music for the duration of the announcement. At the end of the announcement the radio will return to its previous state ready for the next announcement.

Radio Operation (Cont)

1. AF - Alternative Frequency

Press the AF button and the unit will choose the strongest FM signal for the selected station, so that you do not have to re-tune the station when driving between different transmitter coverage areas. When AF is on, it means RDS information is received; when AF is flashing, it means RDS information is not yet received.

2. TA - Traffic Announcement

Press the TA button to activate the Traffic Announcement function in order to receive Traffic Announcements from local radio stations.

To choose the TA mode, press the Volume knob button for 2 seconds, the display will show TA SEEK. Rotate the Volume knob to choose between the TA SEEK and TA ALARM, leave the unit idle for a few seconds for the mode to activate. In TA SEEK mode, the unit will seek Traffic Announcements when TA is pressed; in TA ALARM mode, no TA/TP is displayed and the alarm is set off.

3. PTY - Program Type

This radio will allow you to select the type of programming you would like to listen to, such as Pop, Rock, Jazz, Talk, Classical, News, then search for a station broadcasting that type of programming. Press the PTY button once to show the music type. Then press 1-6 button to choose the different music types available.

Press the PTY button twice to show the speech type program. Then press 1-6 button to choose the different speech type program. Each number key will show 3 different types of programs for you to choose from.

4. MASK DPI - MASK ALL

Press the Volume knob for 2 seconds, the display will show TA SEEK. Press the sound select button again so that the unit will show MASK DPI. Rotate the encoder volume to toggle between MASK DPI and

MASK ALL modes. Then leave the unit idle for the mode to take effect. During MASK DPI mode, the unit will mask only the AF which has different PI (Program Identification), this is the default mode; during MASK ALL mode, the unit will mask the AF which has different PI and no RDS signal with high field strength.

5. RETUNE S/L - SHORT/LONG

This function is to set the initial duration of automatic TA Search -- Press and hold the sound select button until "TA SEEK" is shown on the LCD, then press the SEL button to cycle through the menu selections until "RETUNE_S" is shown, use the VOL +/- button to choose "RETUNE_S" or "RETUNE_L". The default is "RETUNE_S".

CD Operation

Electronic Skip Protection - 10 or 40 seconds Electronic Skip Protection is ideal for driving on rough roads. Press the Volume Knob for 2 seconds. The display will show "DSP OFF". Press the Volume Knob again, "ESP10" will be displayed indicating that Electronic Skip Protection will be activated for 10 seconds. With "ESP 10" on the display, use the Volume Knob to change the setting to "ESP 40", indicating that Electronic Skip Protection for 40 seconds is activated. Leave the unit idle for the new setting to take effect.

1. Insert/Eject CD

Insert a disc into the CD slot with label side up. The disc will be automatically loaded even if the radio is off or in the Radio Mode. The word "LOAD" will blink on the display and the CD will play automatically. Press the EJECT Button to eject the disc from the slot. If the disc is not removed from the slot within 5 seconds, it will automatically be loaded into the slot again. When the disc is ejected and removed, the unit will automati-

CD Operation (Cont)

cally switch to Radio Mode.

2. Multi-Session CD Reading

This unit can read multi-session CDs.

The multi-session reading will be activated automatically if the player detects a file that is written in multi-session format. Press and hold the Volume Knob until "DSP OFF" is shown on the LCD, then press the Volume Knob to cycle through the menu selections until "MULT OFF" is shown. Use the Volume Knob to choose "MULT ON" or "MULT OFF". The default is MULT OFF.

3. Selecting Tracks

On the Remote or Head Unit, press the >>| Button to advance CD to the next track. Track numbers will be shown on the display. Press and hold >>| Button to fast forward. Press the |<< Button to go to a previous track. Track numbers will be shown on the display. Press and hold the |<< Button to fast reverse. Disc will play normally when the >>| or |<< Button is released.

4. Play/Pause CD

On the Remote or Head Unit, press the BND•ID3/>|| Button to pause the CD. Press these buttons again to resume playback.

5. Resume All Tracks

On the Remote or Head Unit, press the 1/TOP Button to play the all the tracks again. The first song on the CD will be played.

6. Scanning Tracks

On the Remote or Head Unit, press the INT/2 Button to play the first 10 seconds of each track. Press this button again to resume playback.

7. Repeat

On the Remote or Head Unit, press the FPS/RPT Button to repeat the same track continuously. "RPT ON" will appear on the

display. Press this button again to cancel the repeat function.

8. Random

On the Remote or Head Unit, press the RDM/4 Button to play all the tracks in random order. "RDM ON" will appear on the display. Press this button again to stop random play.

MP3/WMA on CD

1. Insert/Eject CD

Insert a disc with MP3 and/or WMA files into the CD slot with label side up. The disc will be automatically loaded into the unit, even when the unit is off or in Radio Mode. The word "MP3 DISC" will be displayed as the CD is loaded. The first file in the root folder will be played. As the file is playing, "ROOT" will be displayed first, then if there is any ID3 information available, it will be displayed as the file is playing. Press the EJECT Button to eject the disc from the slot. If the disc is not removed from the slot within 5 seconds, it will automatically be loaded into the slot again. When the disc is ejected and removed, the unit will automatically switch to Radio Mode.

2. Multi-Session CD Reading

This unit reads multi-session CDs.

The multi-session reading will be activated automatically if the player detects a file that is written in multi-session format. Press and hold the Volume Knob until "DSP OFF" is shown on the LCD, then press the Volume Knob to cycle through the menu selections until "MULT OFF" is shown. Use the Volume Knob to choose "MULT ON" or "MULT OFF". The default is MULT OFF .

3. Selecting Tracks

Remote or Head Unit, press the >>| Button to advance CD to the next track. Track numbers will be shown on the display. Press and hold >>| to fast forward.

USB/SD/MMC Card Operation

Press the |<< Button to go to a previous track. Track numbers will be shown on the display. Press and hold the |<< Button to fast reverse. Disc will play normally when the >>| or |<< Button is released.

4. Play/ Pause CD

On the Remote or Head Unit, press the “BND•ID3” button to pause the CD. Press this button again to resume playback.

5. Resume All Tracks

On the Remote or Head Unit, press the 1/TOP Button to play the all the tracks again. The first song on the CD will be played.

6. Scanning Tracks

On the Remote or Head Unit, press the 2/INT Button to play the first 10 seconds of each track. Press this button again to resume playback.

7. Repeat

On the Remote or Head Unit, press the F/PS/RPT Button to repeat the same track continuously. “RPT ON” will appear on the display. Press this button again to stop repeating tracks

8. Random

On the Remote or Head Unit, press the 4/RDM Button to play all the tracks in random order. “RDM ON” will appear on the display. Press this button again to stop random play.

9. UP 10

Press the 6/UP10 Button to advance 10 tracks at a time.

10. DN 10

Press the 5/DN10 Button to go back 10 tracks at a time.

USB Flash Memory

To play MP3/WMA files from a USB flash

memory, insert a USB flash memory into the USB port on the left side of the unit. The unit will start playing MP3/WMA files on the USB flash memory automatically. Or press the MODE Button to select USB after pressing POWER Button to turn on the unit.

SD/MMC Card

To play MP3/WMA files from a SD/MMC Card, insert a SD/MMC Card into the SD Card Slot on the left side of the unit. The unit will start playing MP3/WMA files on the SD/MMC Card memory automatically. Or press the MODE Button to select SD/MMC Card after pressing POWER Button to turn on the unit.

1. Play / Pause

When playing MP3/WMA in the USB drive, press the “BND-ID3” Button to pause playback. Press the Button again to restore.

2. Selecting Tracks

If the MP3/WMA files are stored in folders on the USB drive or SD Card, the unit will start by playing the first song in the first folder.

After playing all the files sequentially in the first folder, the unit will play sequentially all of the files in the next folder. The unit will continue playing through all of the folders on the USB drive or SD Card in this manner. If the USB drive or SD Card has loose files and folders containing files, it will play the loose files sequentially, then it will play the files in the folders sequentially.

The 5/DN10 and 6/UP10 Buttons are used to advance ten tracks at a time or go back ten tracks at a time.

3. Resume All Tracks

On the Remote or Head Unit, press the 1/TOP Button to play the all the tracks again. The first song on the CD will be played.

Search Modes For MP3/WMA Files

4. Scanning Tracks

On the Remote or Head Unit, press the 2/INT Button to play the first 10 seconds of each track. Press this button again to resume playback.

5. Repeat

On the Remote or Head Unit, press the F/PS/RPT Button to repeat the same track continuously. "RPT ON" will appear on the display. Press this button again to stop repeating.

6. Random

On the Remote or Head Unit, press the 4/RDM Button to play all the tracks in random order. "RDM ON" will appear on the display. Press this button again to stop random play.

7. UP 10

Press the 6/UP10 Button to advance 10 tracks at a time.

8. DN 10

Press the 5/DN10 Button to go back 10 tracks at a time.

Search Modes

There are 4 search modes to help find your favorite MP3 & WMA tracks. The search modes only work with MP3/WMA CDs, USB flash memory, and SD Cards with MP3/WMA files. The search modes do not work with any other file types on CDs or USB flash memory.

1. Simple Track Search

Press the |<< or >>| Button to go to the next track or previous track. Press the Number 5 button to go back 10 tracks at once or press the Number 6 button to advance 10 tracks at once.

2. Track Search

Press the F/PS Button and the display will show "TRK SCH". Press the Volume Knob so that "TRK" will blink on the display.

Then use the Volume Knob to choose your desired track and press the Volume Knob again to confirm the selection. The selected track will be searched for and then played.

3. File Search

Press the F/PS Button twice and the display will show "FILE SCH". Press the Volume Knob to enter the root folder of the disc. Use the Volume Knob to choose a folder in the root folder, then press the Volume Knob to confirm. The selected folder will be opened.

4. Character Search

Press the F/PS Button three times and the display will show "CHAR SCH". This is for files by file names. Press the Volume Knob and the first character will blink on the display.

Use the Volume Knob to change the character. Press the SEL button once to confirm the character entered and advance to the next character. After you have input the name, press and hold the Volume Knob to confirm. The song nearest alphabetically to the name input will be found and then begin to play.

Electronic Skip Protection - 120 Seconds

Electronic Skip Protection is ideal for driving on rough roads. Electronic Skip Protection for CD (that contains MP3 or WMA files) is a default feature. Please note that this feature support the CD with Songs encoded at 96Kb/s and 32000Hz.

For songs encoded in higher quality, the anti-shock duration will decrease proportionally to the file size.

RCA Out, SUB Out & ID3 Tag

1. RCA Output

The RCA Output Jacks are on the back of the unit. (Refer to Wiring Diagram) This output is for connecting an amplifier, equalizer, or other audio component that requires a pre-amp out connection. (Red = Right, White = Left) Follow the manufacturers instructions for the audio component that you are connecting.

2. Sub Woofer Output

The Sub Woofer Output Jack is on the back of the unit. (Refer to Wiring Diagram) This output is for connecting an amplifier, that requires a pre-amp out connection. (Red = Right, White = Left)

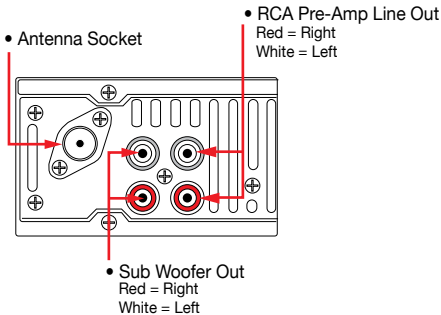

To use the Subwoofer Out Jack press SUB/# Button on the front panel, or press the #/SUB Button on the remote control to turn the Sub Woofer Jack ON or OFF.

The unit must have an external amplifier installed to drive the subwoofer.

Follow the manufacturers instructions for the audio component that you are connecting.

ID3 TAG & SCROLLING MODES

If an MP3 or WMA file has ID3 Tag information, it will be displayed on the LCD in one of 2 scroll modes, SCROLL 1 or SCROLL 2.

ID3 information varies from file to file

If there is no ID3 Tag information, nothing will shown on LCD. Press the BND/ID3 button anytime to view the ID3 information of the song.

SCROLL 1 displays the ID3 information 8 characters at a time.

SCROLL 2 displays the ID3 information by displaying the first 8 characters, then scrolls the information across the LCD from left to right.

To choose a scroll mode, press and hold the Volume knob and DSP Off will be displayed.

Press the volume knob 5 more times and SCROLL 1 will be displayed.

Rotate the Volume knob to change between the 2 modes. Leave the unit idle for a few seconds and the ID3 information will automatically start scrolling.

Both Scroll modes display the same information in the same order.

MAINTENANCE

Cleaning the Unit

Do not use any liquids to clean this unit.

Do not use petroleum distillates to clean this unit.

Use a clean, dry cloth to clean this unit.

Replacing the Fuse

Make sure the amperage matches the specified value when replacing the fuse(s). If the fuse is bad, check the power connection and replace the fuse with a new one. If the same problem occurs, this might indicate a malfunction within the unit.

WARNING

When replacing a fuse, do not use a fuse with a higher amperage rating than the fuse originally supplied with your unit, otherwise damage will result to your unit.

Specifications

GENERAL

Operating Power	12 Volts DC, Negative Ground
Output Wiring	Designed for using four speakers only
Maximum Output Power	4x45 Watts
RMS Output Power	4x16 Watts@4ohms<1% THD+N>60dB Ref. 1 Watt Output@14.4VDC
RCA line out	low-level outputs - 1000MV
Output Impedance	Compatible 4 to 8 Ohm Speakers
Fuses	1 amp and 10 amp
Dimensions	178mm(W) x 178mm(D) x 51mm (H)
Weight	2.3 Kg

CD PLAYER

Signal / Noise Ratio	>80dB
Frequency Response	20 Hz~20KHz
Channel Separation	>50dB
D / A Converter	1 Bit

FM TUNER

Tuning Range	(USA) - 87.5 - 107.9MHz, (Europe) - 87.5 - 108 MHz
FM Sensitivity	12dBu
Stereo Separation @ 1 KHz	35dB

AM TUNER

Tuning Range	(USA) -- 530-1710 KHz, (Europe) -- 522-1620 KHz
Am Sensitivity	30dBu



GIVE US A CALL, WE'LL HELP YOU INSTALL.

PLEASE DO NOT RETURN PRODUCT TO STORE.
Visit us on the WEB

www.vr-3.com

**For Information and Technical Assistance,
Call Toll-Free in U.S.A. and Canada.**

1-800-445-1797

Limited Warranty

VIRTUAL REALITY VIDEO LABS® products are designed and manufactured to provide a high level of trouble-free performance. VIRTUAL REALITY VIDEO LABS® warrants, to the original purchaser, that its products are free from defects in material and workmanship for 30 days from the date of original purchase, as part of our commitment to product excellence. VIRTUAL REALITY VIDEO LABS® and/or its affiliates routinely improve the designs, materials or production methods of its existing products. Because it is impractical to publicize all changes in every product, we reserve the right to make such changes without notice.

CONDITIONS OF WARRANTY:

If during the 30 day warranty period your new product is found to be defective, VIRTUAL REALITY VIDEO LABS® will repair such defect, or replace the product, without charge for parts or labor subject to the following conditions:

1. All repairs must be performed by VIRTUAL REALITY VIDEO LABS® and/or its affiliates in Eatontown, New Jersey.
2. The equipment must not have been altered or been damaged through negligence, accident, or improper operation.
3. The replacement of parts are exempted from this warranty when replacement is necessary due to normal wear and tear.
4. All warranty claims must be accompanied by a copy of the sales receipt or bill of sale.
5. Repair or replacement parts supplied by VIRTUAL REALITY VIDEO LABS® under this warranty are protected only for the unexpired portion of the original warranty.
6. In the case of car stereos, this warranty does not extend to the elimination of car static or motor noise; correction of antenna problems; costs incurred for the removal or reinstallation of the product; damage to tapes, speakers, accessories or car electrical systems.
7. VIRTUAL REALITY VIDEO LABS® will not be responsible for any charge incurred for installation.

OWNER'S RESPONSIBILITIES:

VIRTUAL REALITY VIDEO LABS® will make every effort to provide warranty service within a reasonable period of time.

SHOULD YOU HAVE ANY QUESTIONS ABOUT SERVICE RECEIVED, OR IF YOU WOULD LIKE ASSISTANCE IN OBTAINING SERVICE, PLEASE CALL TOLL FREE 1-800-445-1797, 8:30am - 4:30pm EST.

In order to provide you with the proper warranty service, we request that you adhere to the following procedure:

1. Include a copy of your sales receipt or bill of sale with your unit when it is returned for warranty service.
2. If it is necessary to return your product for service, please return it securely packed, preferably in the original shipping carton, and freight and insurance prepaid to the following address: VIRTUAL REALITY VIDEO LABS, Service Department, 41 James Way, Eatontown, New Jersey 07724.
3. Please include a detailed explanation of the problem you are having.
4. If your product is found by VIRTUAL REALITY VIDEO LABS® to have a defect in material or workmanship, within the warranty period, it will be repaired or replaced at no charge and returned to you prepaid. Where permitted by law VIRTUAL REALITY VIDEO LABS® liability shall be limited to that set forth in this warranty. This warranty shall be the exclusive remedy of the purchaser.

VIRTUAL REALITY VIDEO LABS® makes no other warranty of any kind, expressed or implied; and all implied warranties, are hereby disclaimed by VIRTUAL REALITY VIDEO LABS® and excluded from this warranty, VIRTUAL REALITY VIDEO LABS® and/or its affiliates, the manufacturer, distributor and seller shall not be liable for any injury, loss or damage, incidental or consequential, arising out of the use or intended use of the product.

Free Manuals Download Website

<http://myh66.com>

<http://usermanuals.us>

<http://www.somanuals.com>

<http://www.4manuals.cc>

<http://www.manual-lib.com>

<http://www.404manual.com>

<http://www.luxmanual.com>

<http://aubethermostatmanual.com>

Golf course search by state

<http://golfingnear.com>

Email search by domain

<http://emailbydomain.com>

Auto manuals search

<http://auto.somanuals.com>

TV manuals search

<http://tv.somanuals.com>