

PUNCH  
STATUS  
DISPLAY  
PSD-1

INSTALLATION & OPERATION





*Dear Customer,*

*Congratulations on your purchase of the world's finest brand of car audio accessories. At Rockford Fosgate we are committed to musical reproduction at its best, and we are pleased you chose our product. Through years of engineering expertise, hand craftsmanship and critical testing procedures, we have created a wide range of products that reproduce music with all the clarity and richness you deserve.*

*For maximum performance we recommend you have your new Rockford Fosgate product installed by an Authorized Rockford Fosgate Dealer, as we provide specialized training through Rockford Technical Training Institute (RTTI). Please read your warranty and retain your receipt and original carton for possible future use.*

*To add the finishing touch to your new Rockford Fosgate image, order your Rockford accessories, which include everything from T-shirts and jackets to hats and sunglasses.*

*To get a free brochure on Rockford Fosgate products and Rockford accessories, in the U.S. call 602-967-3565 or FAX 602-967-8132. For all other countries, call +001-602-967-3565 or FAX +001-602-967-8132.*

## **PRACTICE SAFE SOUND™**

CONTINUOUS EXPOSURE TO SOUND PRESSURE LEVELS OVER 100dB MAY CAUSE PERMANENT HEARING LOSS. HIGH POWERED AUTO SOUND SYSTEMS MAY PRODUCE SOUND PRESSURE LEVELS WELL OVER 130dB. USE COMMON SENSE AND PRACTICE SAFE SOUND.

If, after reading your manual, you still have questions regarding this product, we recommend that you see your Rockford Fosgate dealer. If you need further assistance, you can call us direct at 1-800-795-2385. Be sure to have your serial number, model number and date of purchase available when you call.

The serial number can be found on the outside of the box. Please record it in the space provided below as your permanent record. This will serve as verification of your factory warranty and may become useful in recovering your product if it is ever stolen.

Serial Number: \_\_\_\_\_

Model Number: \_\_\_\_\_

# TABLE OF CONTENTS

---

Introduction .....	1
Accessory Pack .....	1
Design Features .....	2
Installation Considerations .....	3
Mounting Locations .....	4
Wiring the System .....	5
Installation .....	6
System Diagrams .....	10
Rockford Fosgate Accessories .....	14
Troubleshooting .....	14
Specifications .....	16
Warranty Information .....	17
International Information .....	18

## GETTING STARTED

---

Welcome to Rockford Fosgate! This manual is designed to provide information for the owner, salesperson and installer. For those of you who want quick information on how to install this product, please turn to the **Installation Section** of this manual or refer to the icons listed below. Other information can be located by using the Table of Contents. We, at Rockford Fosgate, have worked very hard to make sure all the information in this manual is current. But, as we are constantly finding new ways to improve our product, this information is subject to change without notice.



Sections marked **INSTALLATION** include "slam dunk" wiring connections

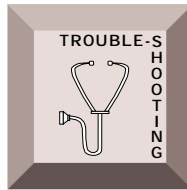

Sections marked **TROUBLESHOOTING** include recommendations for curing installation problems

# **INTRODUCTION**

---

The Punch Status Display is an LED array which monitors amplifier performance. The PSD is a 2-channel monitor which has an indicator for Power, three indicators for Signal Level (sig-max-clip), and an indicator for Thermal condition. The display is designed to be stackable for multiple amplifier monitoring and can be used with compatible Rockford Fosgate stereo and mono amplifiers.

We recommend you have your Authorized Rockford Fosgate Dealer install your new accessory. If you do choose to install the accessory yourself, please be sure to read the entire manual before beginning.

## **ACCESSORY PACK**

---

- (1) 20' Data Interface Cable (8 conductor non-flipped)
- (1) Remote/Dimmer Harness (2-pin)
- (1) Mounting Bezel
- (1) Backstrap
- (1) Backstrap Screw (4-40 x 3/8")
- (1) Backstrap Washer (#4)

# DESIGN FEATURES

---

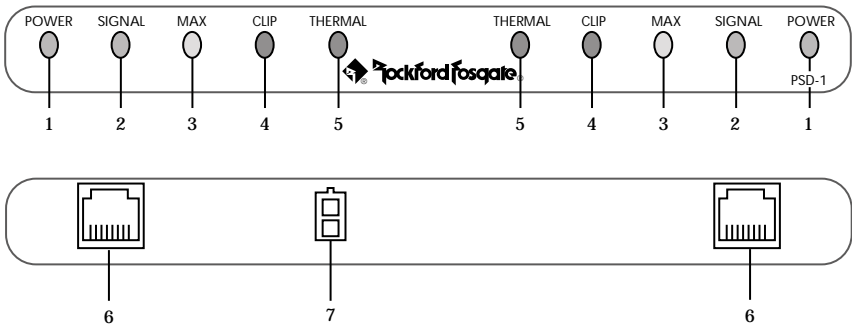

1. **POWER Indicator** – The POWER LED will illuminate when the amplifier turns on.
2. **SIGNAL Indicator** – The SIGNAL LED will illuminate when audio signal is present at the amplifier.
3. **MAX Indicator** – The MAX LED will illuminate when the audio signal has reached its maximum amplified level (approximately  $-2\text{dB}$  from clip).
4. **CLIP Indicator** – The CLIP LED will illuminate when the audio signal has exceeded (clipped) its maximum amplified level.
5. **THERMAL Indicator** – The THERMAL LED will illuminate when a fault is detected by the protection circuitry in the amplifier's power supply. The power supply protection circuitry monitors overvoltage, undervoltage and thermal conditions.
6. **Data Interface Jacks** – The RJ45 interface provides a convenient connection for the data interface cable.
7. **Remote/Dimmer Connector** – The mini 2-pin connector provides a convenient connection for Remote Turn-On and Dimmer input.

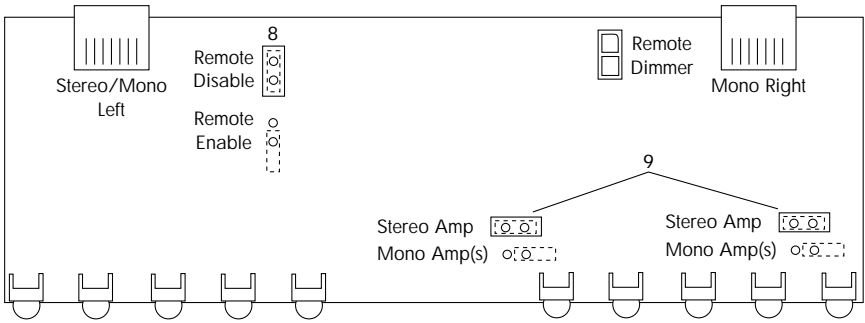

- 8. Remote Disable/Enable Jumper** –The position of this jumper determines whether the PSD is turned on and off by the amplifier or with a separate switch.
- 9. Stereo/Mono Jumpers** – These jumpers are used to configure the PSD for Stereo or Mono amplifier input(s).

## INSTALLATION CONSIDERATIONS

The following is a list of tools you will need for installing the PSD:

- |   |                           |
|---|---------------------------|
| Battery Post Wrench                         | Soldering Iron (optional) |
| #1 Phillips Screwdriver                     | Solder (optional)         |
| Wire Strippers (optional)                   | Heat Gun (optional)       |
| 1/8" diameter heat shrink tubing (optional) |                           |

This section focuses on some of the vehicle considerations for installing your new PSD. Pre-planning your layout and best wiring routes will save installation time.

1. **For safety**, disconnect the negative lead from the battery prior to beginning the installation.
2. For easier assembly, we suggest you run all wires prior to mounting your Punch Status Display.
3. **Think before you drill!** Be careful not to cut or drill into vacuum lines or electrical wiring when working on any vehicle.
4. Never run wires underneath the vehicle. Running the wires inside the vehicle provides the best protection.
5. Avoid running wires over or through sharp edges. Use rubber or plastic grommets to protect any wires routed through metal.
6. **ALWAYS** protect the battery and electrical system from damage with proper fusing. **Be sure the Remote and Dimmer wires are connected to an appropriately fused electrical system.**

# MOUNTING LOCATIONS

---

The Punch Status Display can be installed in a wide range of operating locations. However, care should be taken to ensure optimum monitoring without causing distractions under normal driving conditions. Listed below are the following options for installation.

## Engine Compartment

Mounting the Punch Status Display in the engine compartment will **void your warranty**. We didn't think you would actually install the PSD in the engine compartment. We just wanted to make sure you were paying attention to the installation instructions.

## Instrument Panel

Mounting the Punch Status Display in the **instrument panel provides optimum monitoring**. The PSD should be securely mounted using the "Standard Mount" or "ISO Mount" method.

## Center Console

Mounting the Punch Status Display in the **center console panel provides optimum monitoring**. The PSD should be securely mounted using the "Standard Mount" or "ISO Mount" method.

## Glove Box

Mounting the Punch Status Display **in the glove box is adequate**, but does not provide easy monitoring. Glove Box mounting should only be done if "Instrument Panel" or "Center Console" mounting are not acceptable (i.e., maintaining integrity of older vehicles with metal dashboards).

## Under Dash

Mounting the Punch Status Display **under the dash is adequate**, but does not provide easy monitoring. Under dash mounting should only be done if "Instrument Panel," "Center Console" or "Glove Box" mounting are not possible. Mount the PSD to the side of the driver's area to reduce interference with the parking brake, gear shift or operating pedals.



# WIRING THE SYSTEM

---

*For safety, disconnect the negative lead from the car battery prior to beginning the installation.*

1. **Route the Data Interface Cable** inside the vehicle to provide the best protection. Leave slack at each end of the cable for the connection of the PSD and amplifier.
2. **Configure the Stereo/Mono Jumpers** by removing the two Phillips screws from each side of the PSD that hold the sheet metal top in place. Remove the sheet metal and locate the Stereo/Mono jumpers on the PC board. To accept a Stereo amplifier input, both jumpers should be **INSTALLED** on the jumper pins. To accept a Mono or pair of Mono amplifier inputs, both jumpers should be **REMOVED** from the jumper pins.
3. **Configure the Remote Jumper** located on the PC board. The position of this jumper determines whether the PSD is controlled by the amplifier or separately. When **INSTALLED**, the Remote Turn-On wire is disabled and the amplifier will automatically turn on the PSD. When the jumper is **REMOVED**, the Remote Turn-On wire is enabled and the PSD is controlled by an optional switch. Determine which method is preferable for your particular application. **NOTE: The Remote Jumper must be *enabled* when using a Power 250m<sup>2</sup>, Power 500m or Power 250m.**
4. When connecting the Remote/Dimmer Harness leads to the electrical system, solder and heat shrink all connections for a reliable installation. For each connection, cut a 1" piece of heat shrink tubing and slide over one of the wires. Strip each wire 3/8", then twist together and solder. Slide the tubing over the connection and shrink the tubing with a hot air gun until no bare wire is exposed.

The **Remote Turn-On (Blue)** lead should be connected (when Remote Jumper is enabled) to the remote turn-on or power antenna output from the source unit. An in-line switch may be used if you would like to disable the PSD during operation.

The **Dimmer (Orange)** lead should be connected to the "park light" or to a switched +12 volt source when the headlights are turned on.

5. **Adjust system gains *prior* to installing the Punch Status Display**  
Although the PSD does monitor the output signal from the amplifier it is not designed as a replacement for an oscilloscope or other specialized test equipment.
6. **Plug in the Data Interace Cable and Remote/Dimmer Harness** into the rear of the PSD and check for frayed wires or loose connections.



## Remote Turn-On/Dimmer Wiring

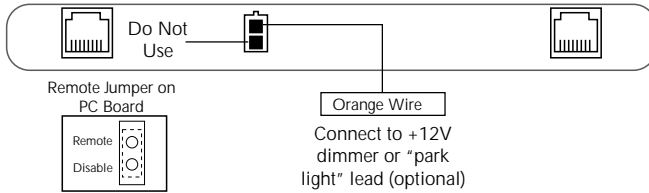

- **Remote Turn-On (Blue Wire)** *not used* when Remote Jumper has been DISABLED (installed)
- **Dimmer (Orange Wire)** will *dim LEDs* when connected to dimmer or "park light" lead (+12V when headlights are turned on)

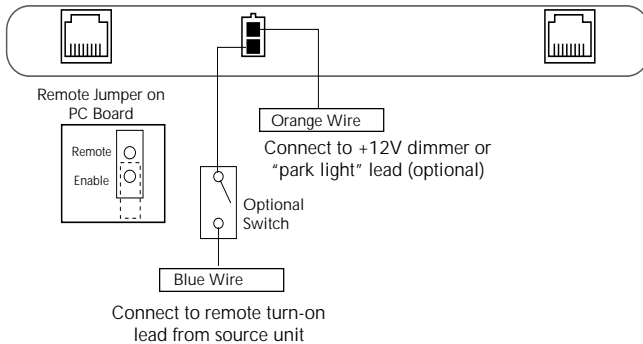

- **Remove Cover** to access Remote Jumper by removing 2 screws on each side of the PSD
- **Remote Turn-On (Blue Wire)** connects to source unit's accessory turn-on lead when Remote Jumper has been ENABLED (removed)
- **An Optional Switch** can be used to turn off the PSD independently from the audio system
- **Dimmer (Orange Wire)** will *dim LEDs* when connected to dimmer or "park light" lead (+12V when headlights are turned on)

**NOTE:** The Power 250m<sup>2</sup>, Power 250m and Power 500m must use the ENABLED Remote turn-On for proper operation.

## Stereo/Mono Jumper Configuration (2-Channel Amp)

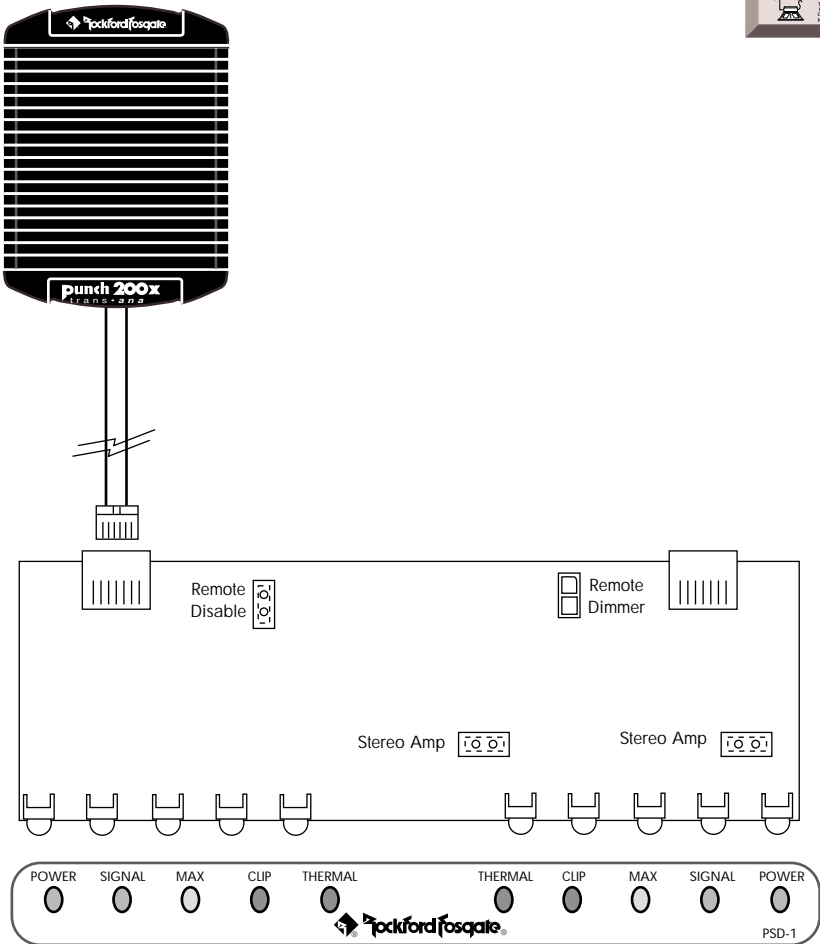

- Stereo/Mono Jumpers are *installed* on jumper pins
- 2-Channel Amp connects to *Stereo/Mono Left* input

## Stereo/Mono Jumper Configuration (Mono Amp/s)

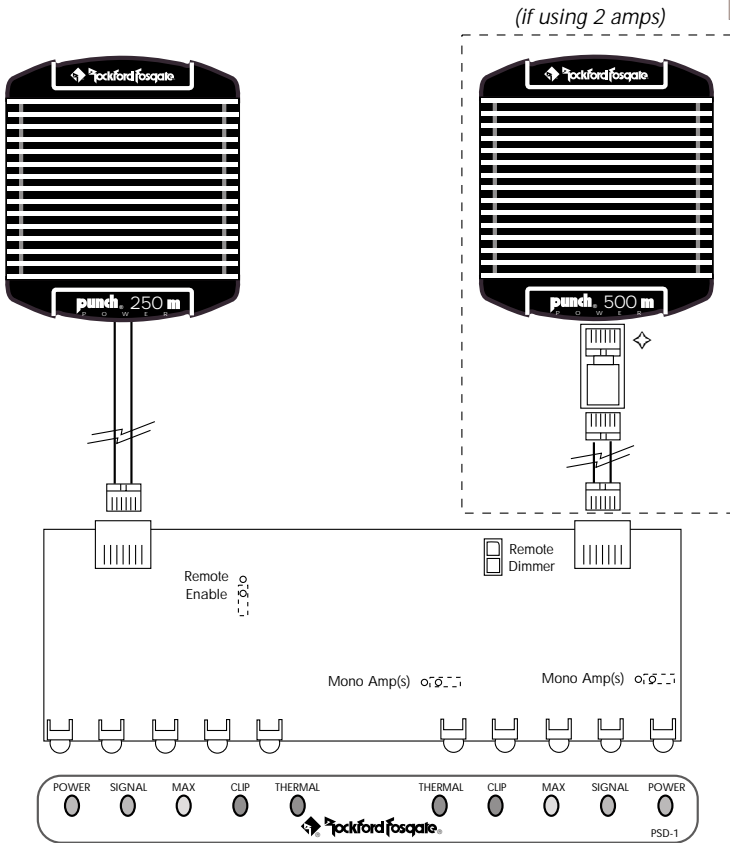

- **Stereo/Mono Jumpers** are *removed* from jumper pins
- **Single Mono Amp** connects to *Stereo/Mono Left* input
- **Left Mono Amp** connects to *Stereo/Mono Left* input
- **Right Mono Amp** connects to *Mono Right* input

**NOTE:** The Power 250m<sup>2</sup>, Power 250m and Power 500m must use the **ENABLED Remote Turn-On** for proper operation.

- ◇ **Adapter** used on Power 500m amplifier only
- **Power 500 Adapter** must connect to the amplifier side of the Data Interface Cable for proper operation

**DO NOT** connect Power 500m amplifiers to the PSD without the appropriate adapter. Please contact Rockford Customer Service (800-669-9899) for information

## Standard Mount

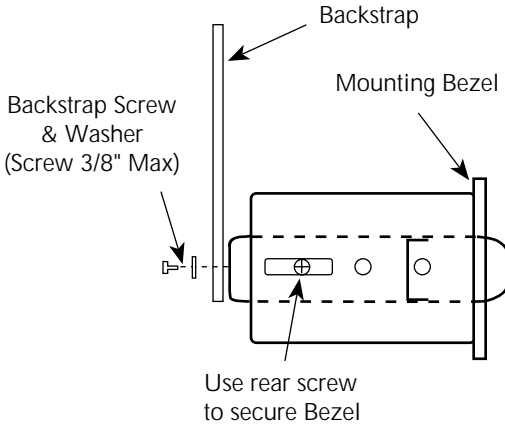

- **Install PSD** into mounting bezel using the rear screw
- **Mount Backstrap** securely to the PSD and the instrument panel
- **Backstrap Screw** should be 3/8" max. (use supplied screw)

---

## ISO Mount

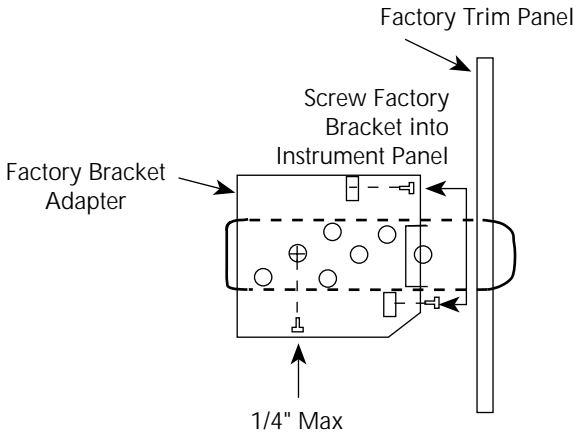

- **Install PSD** securely into instrument panel with the factory bracket adapter
- **Factory Bracket** should align with mounting holes on each side of PSD
- **ISO Screws** should be 1/4" max. (use existing screws)

# SYSTEM DIAGRAMS

## Single Amp System

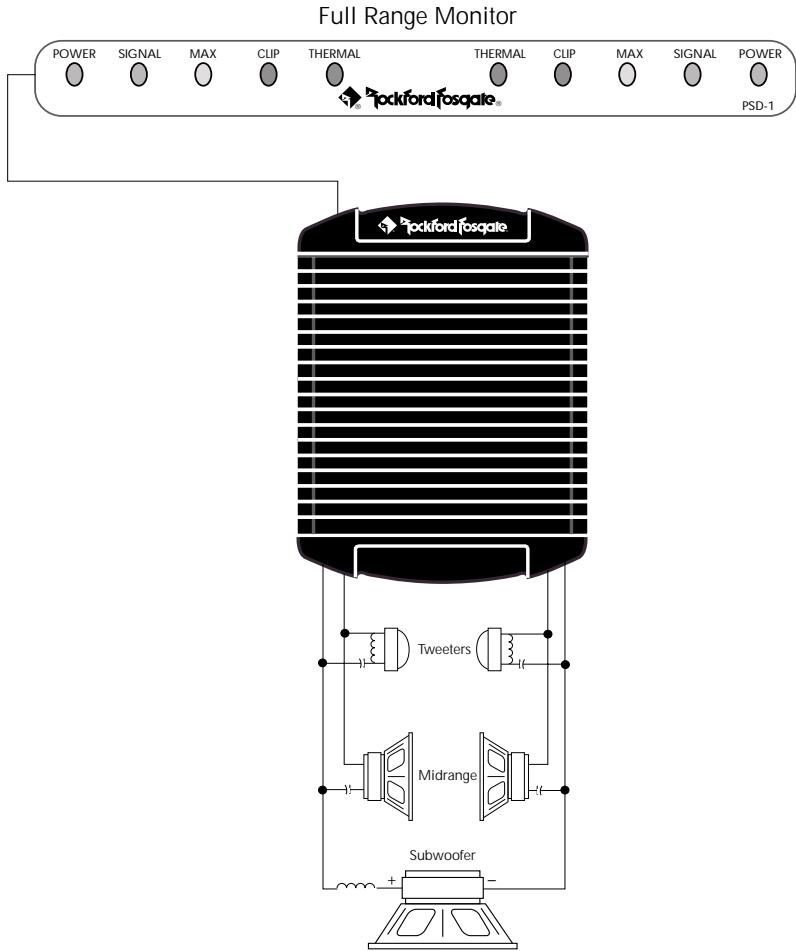

# Bi-Amp System

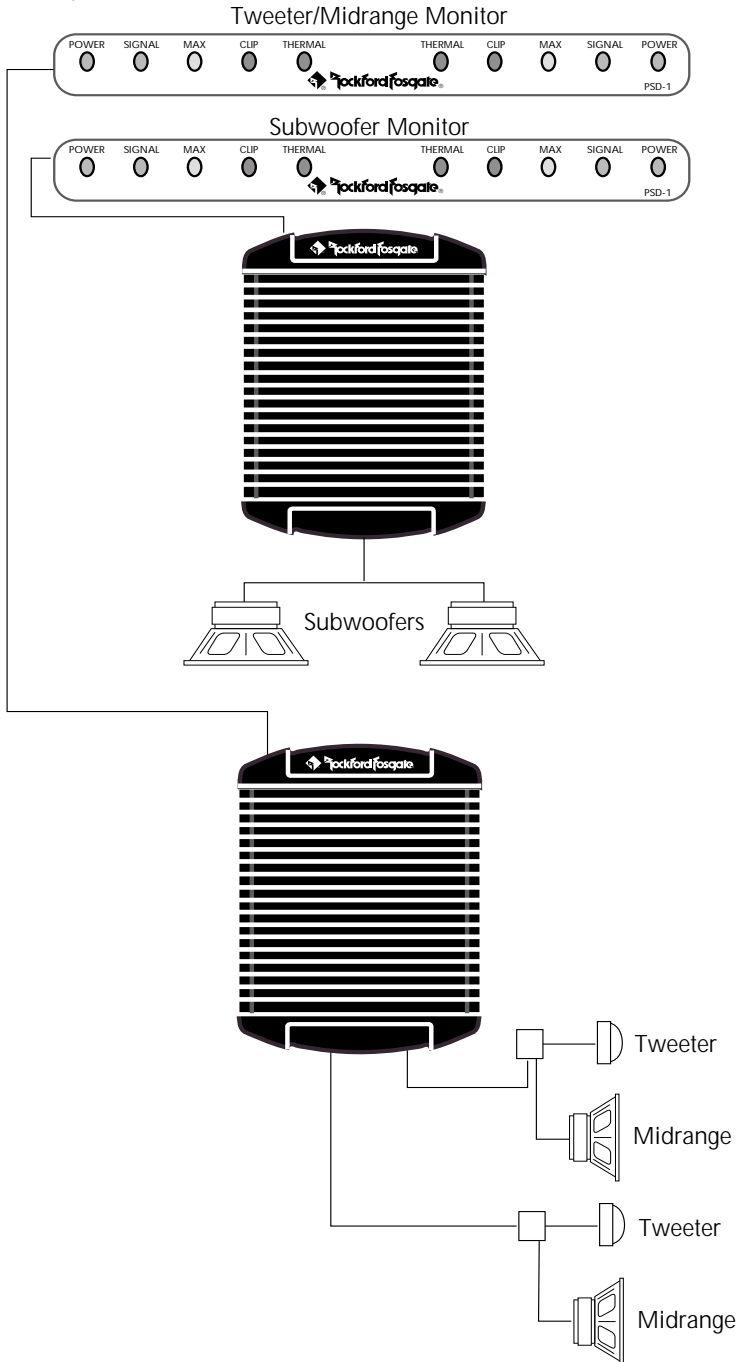

# Tri-Amp System #1

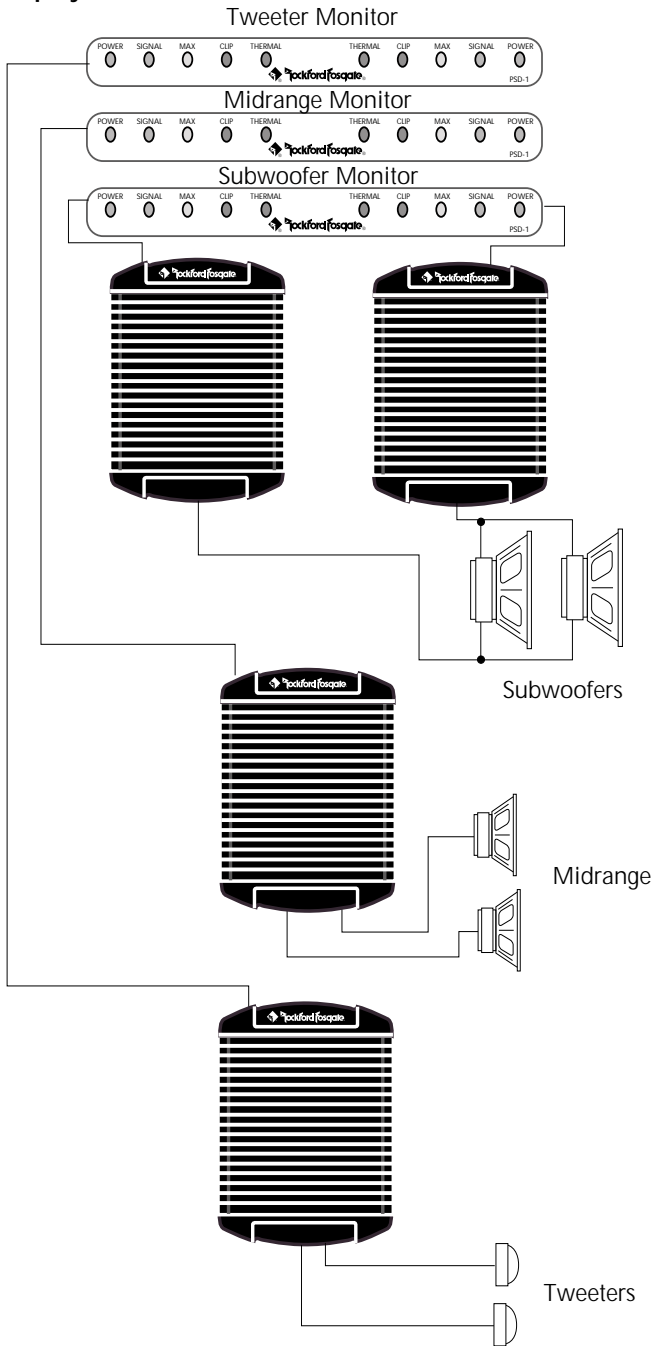



# Tri-Amp System #2

## Front Stage Monitor



## Rear Stage Monitor



## Subwoofer Monitor

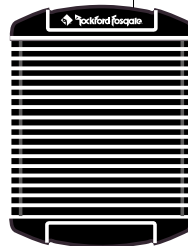
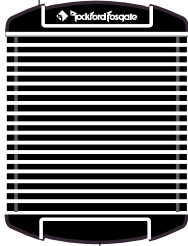

Subwoofers

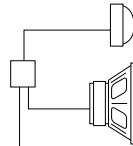
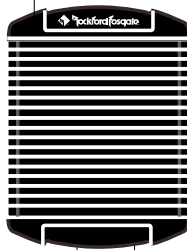
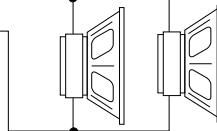

Rear Stage

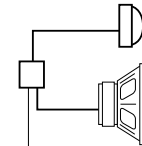
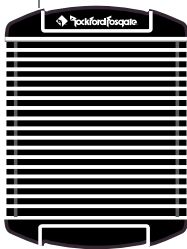

Front Stage

# ROCKFORD FOSGATE ACCESSORIES

## PSD CABLES (CC-1188)

20 foot 8-conductor cables are available separately for the connection of an additional mono amplifier to Punch Status Display. This will allow the PSD to accommodate a pair of Mono amplifiers operating individually or a pair of Mono amplifiers bridged.

## TROUBLESHOOTING



Symptom	Diagnosis	Remedy
PSD does not turn on (Remote Disabled)	Remote Turn-On wire must be used with a 250m <sup>2</sup> , 500m or 250m	Enable Remote jumper and connect Remote Turn-On (blue wire) to a source of switched +12V
	Data Interface Cable between amplifier and PSD is damaged	Check connections, substitute with known working cable and repair or replace as necessary
	Amplifier is not working properly	Check connections, substitute with known working amplifier and repair or replace as necessary
PSD does not turn on (Remote Enabled)	Voltage applied to the PSD Remote Turn-On wire is not between 8 and 15.5 or there is no voltage present	Check wiring and repair if necessary. If voltage is above 15.5 volts, have the electrical system inspected by an authorized car service center
	Optional switch (if used) is damaged or in the "OFF" position	Bypass switch – if PSD turns on, check connections and switch position and repair or replace as necessary
	Data Interface Cable between amplifier and PSD is damaged	Check connections, substitute with known working cable and repair or replace as necessary
	Amplifier is not working properly	Check connections, substitute with known working amplifier and repair or replace as necessary



Symptom	Diagnosis	Remedy
PSD does not turn on (Thermal LED on)	Amplifier has overheated and activated its thermal protection	Turn the system off and wait approximately 15 minutes for the amplifier to cool down.
	Voltage applied to the amplifier Remote Turn-On is not between 8 and 15.5 volts	Check wiring and repair if necessary. If voltage is above 15.5 volts, have the electrical system inspected by an authorized car service center
Random LEDs Illuminate	Stereo amplifier is not connected to proper input	Connect stereo amplifier to Stereo/Mono Left input only
	Single Mono amplifier is not connected to proper input	Connect single Mono amplifier to Stereo/Mono Left input only
Both POWER and/or THERMAL LEDs do not illuminate (Stereo Amp Connected)	Stereo/Mono jumpers are removed from jumper pins	Check jumper configurations and repair as necessary
Both POWER and/or THERMAL LEDs illuminate (Mono Amp Connected)	Stereo/Mono jumpers are installed on jumper pins	Check jumper configurations and repair as necessary
LEDs do not dim (Headlights turned on)	Voltage applied to the Dim (orange) wire is not between 10.5 and 15.5 volts	Connect voltmeter to source of switched +12 volts and verify voltage. Repair wiring as necessary or find an alternate +12 volt source
	Dim (orange) wire is not connected to a source that switches to +12 volts when the headlights are turned on	Repair wiring as necessary or find an alternate +12 volt switched source
PSD shuts off when amp thermals (Remote Enabled)	Voltage applied to the Remote Turn-On (blue) wire is not between 8 and 15.5 volts or there is no voltage present	Check wiring and repair if necessary. If voltage is above 15.5 volts, have the electrical system inspected by an authorized car service center

# SPECIFICATIONS

Number of Channels	2
Number of Inputs	2 (Stereo/Mono Left & Mono Right)
Dimmer Level	Approximately Half Illumination
Remote Turn-On	+8 V to activate
Dimmer	+10.5 V to activate

LED Indicator	Threshold of Illumination
POWER	Amplifier Remote Turn-On
SIGNAL	Equivalent to 1 Watt of amplifier power @ 4 ohms
MAX	-2dB from clipping (may vary upon unit)
CLIP	Signal Clipping
THERMAL	≥ +90° C (+194° F) amplifier temperature or protection of power supply due to under/over voltage

PSD Dimensions:

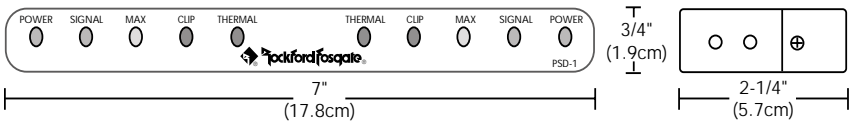

Mounting Bezel Dimensions:

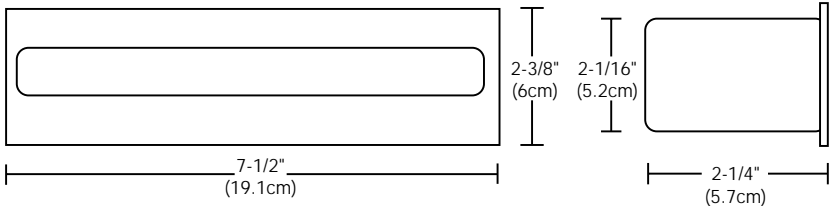

# WARRANTY INFORMATION

---

Rockford Fosgate warrants all electronics to the original consumer/purchaser to be free from defects in materials or workmanship for a period of three (3) years. We will cover parts and labor provided the product was purchased from an Authorized Rockford Fosgate Dealer. This warranty does not apply to any product on which the seals and/or serial number have been broken, removed, tampered with, defaced or altered in any manner. This warranty only applies to the original consumer/purchaser and is not transferable.

Electronics found to be defective during the warranty period will be repaired or replaced at Rockford Fosgate's discretion. Repaired or replaced electronics will be covered by the balance of the original warranty period only. Rockford Fosgate shall not be responsible for any incidental or consequential damages resulting from a defect in electronics. Some states do not allow the exclusion or limitation of incidental or consequential damages, so the previous limitation may not be applicable.

The warranty does not cover any appearance item, any cost or expense related to the removal or reinstallation of the product, any accessory used in conjunction with the product, damage to the product resulting from alteration, accident, misuse or abuse, or improper installation. This warranty does not apply if the parts or labor, which would otherwise be provided without charge under this warranty, are obtained from any source other than Rockford Fosgate or an Authorized Rockford Fosgate Service Center.

This warranty is the only express warranty and does not create any implied warranties. Rockford Fosgate limits its obligations under any implied warranties under state laws to a period not to exceed the written warranty period. Some states do not allow limitation on how long an implied warranty lasts, so the above limitation may not apply. This warranty applies only to products sold in the United States of America or its possessions. For warranty outside the U.S.A., please contact the nearest Authorized Rockford Fosgate Dealer. This warranty gives the consumer specific legal rights, and the consumer may have other rights which vary from state to state.

A defective product must be shipped prepaid to the Authorized Rockford Fosgate Dealer from which the consumer purchased the product or to the Rockford Fosgate factory in Tempe, Arizona in the original factory carton or equivalent. Any shipping loss or damage will be borne by the consumer or the consumer's shipper. A consumer returning a product to the factory must call (800) 669-9899 for a Return Authorization Number. All shipments shall be clearly marked with the Return Authorization Number on the outside of the shipping carton.

Ship to:  
Rockford Corporation  
Warranty Repair Department  
2055 E. 5th Street  
Tempe, AZ 85281 U.S.A.  
Return Authorization Number: \_\_\_\_\_



# CONECTANDO EL SISTEMA

*Por seguridad, desconecte el borne negativo de la batería de su coche antes de comenzar la instalación.*

1. **Coloque el cable de Interficie de Datos** en el interior de su vehículo de manera que éste quede protegido. Deje un trozo libre y suelto en cada extremo del cable para poder conectar el PSD y el Amplificador.
2. **Configure el Remote Jumper** situado en la placa PC. La posición de éste jumper determina si el PSD está controlado por el amplificador o independientemente. Si está colocado, el cable de encendido remoto es activado y el PSD es controlado por un interruptor separado. Determine que método prefiere particularmente. **NOTA: El jumper de Remote debe estar colocado cuando use usted un Power 250m<sup>2</sup>, un Power 500m o un Power 250m.**
3. El **cable del encendido remoto (Azul)** debe estar conectado (cuando el jumper de remoto también está conectado) al encendido remoto o a la salida de alimentación de la antena de su unidad fuente. Debe utilizar un interruptor en la propia línea o cable si quiere desactivar el PSD.
4. El **cable de Dimmer (Naranja)** debe estar conectado a las "luces de posición" o a una fuente que entregue +12 voltios cuando los faros sean encendidos.
5. **Ajuste las ganancias del sistema antes de instalar el visualizador del estado de Punch.**  
Aunque el PSD permita monitorizar la señal del amplificador, no está diseñado para reemplazar un osciloscopio u otro aparato de test especializado.



## Conexión del encendido remoto y del Dimmer

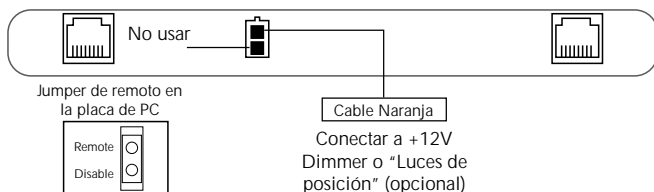

- **Encendido Remoto (cable Azul)** *no usado* cuando el jumper del remoto ha sido desactivado
- **Dimmer (cable Naranja)** *oscurecerá los LEDs* cuando sea conectado al cable de dimmer o de "luces de posición" (+12 V cuando los faros sean encendidos)

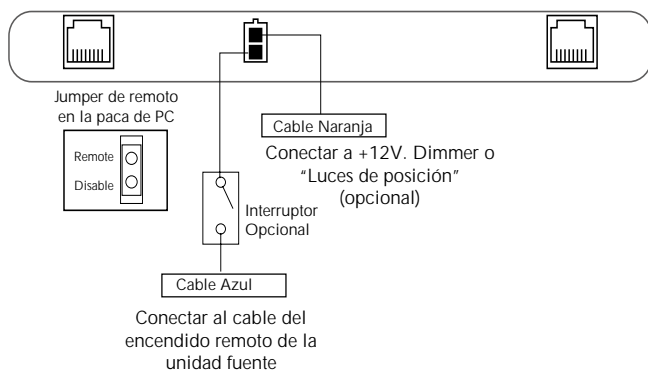

- **Levante la cubierta** para acceder al jumper de remoto sacando los dos tornillos
- **Conecte el cable del encendido remoto (Azul)** al encendido remoto si el jumper ha sido activado
- **Un interruptor opcional** puede ser usado para desconectar el PSD independientemente del sistema de sonido
- **Dimmer (cable Naranja)** *oscurecerá los LEDs* cuando sea conectado al cable de dimmer o de "luces de posición" (+12 V cuando los faros sean encendidos)

**NOTA: El Power 250m<sup>2</sup>, Power 500m y Power 250m deben usar el encendido remoto en modo activado para un mejor funcionamiento**



## Configuración de los Jumpers (Amplificador de 2 canales)

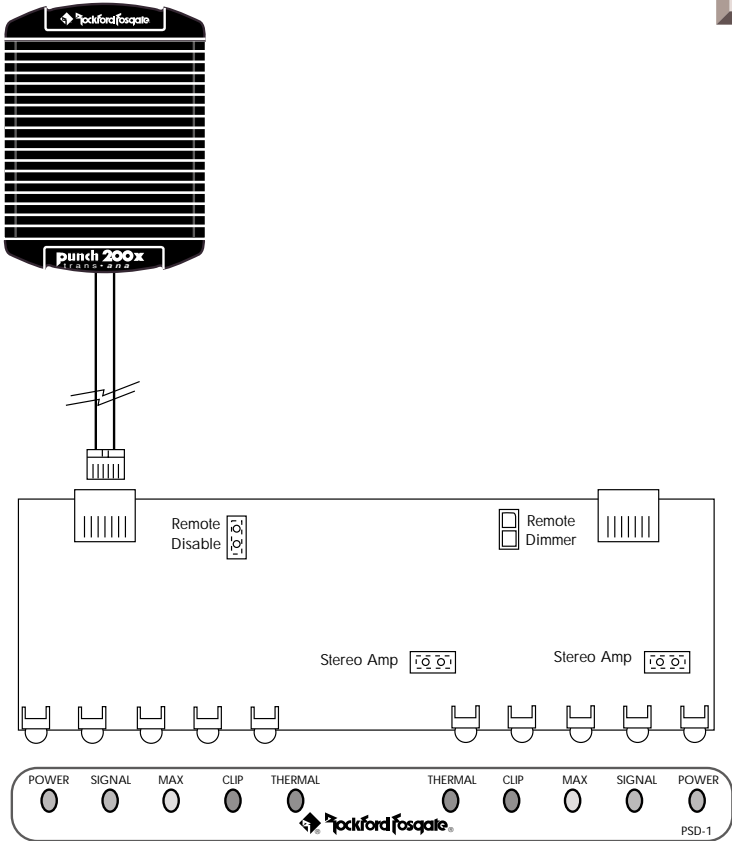

- Los jumpers Stereo/Mono están colocados en los pines para jumpers
- 2-Channel Amp se conecta a la entrada Stereo/Mono Left

## Configuración de los Jumpers (Amplificador/es Mono)

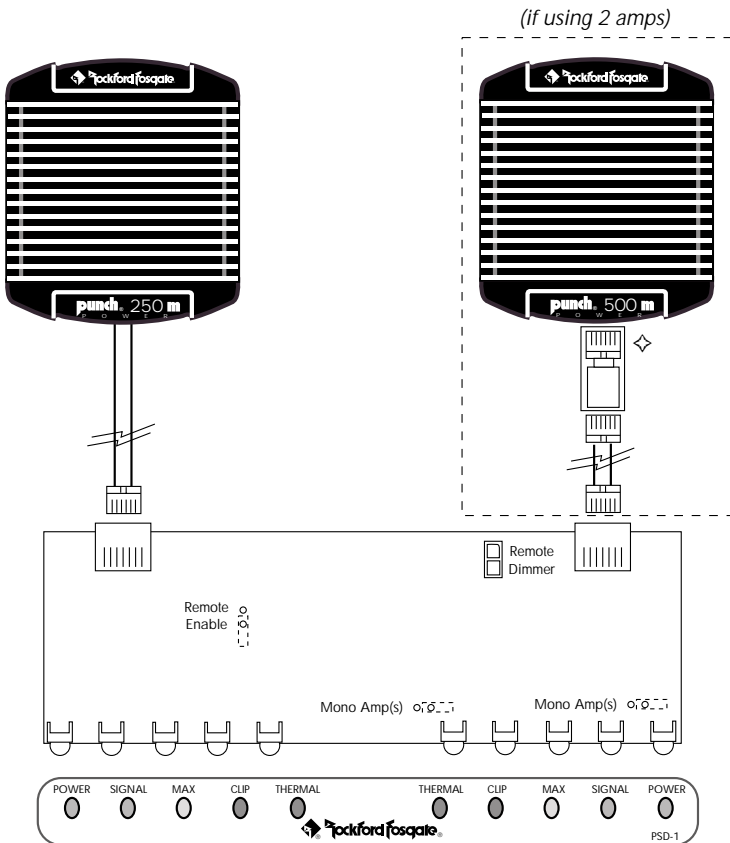

- Los Jumpers Stereo/Mono son *sacados* de los pines para jumpers
- Single Mono Amp se conecta a la entrada Stereo/Mono Left
- Mono Amp Left se conecta a la entrada Stereo/Mono Left
- Mono Amp Right se conecta a la entrada Mono Right

*NOTA: El Power 250m<sup>2</sup>, Power 500m y Power 250m deben usar el encendido remoto en modo activado para un mejor funcionamiento*

- ◇ Adaptador utilizado sólo en los amplificadores Power 500m
- El Adaptador del Power 500m debe conectar la banda del amplificador del cable de Interficie de Datos para un funcionamiento correcto

***No Conecte los amplificadores Power 500m al PSD sin el adaptador apropiado. Por favor, contacte con el service al cliente de Rockford para más información (800-669-9899)***

# BRANCHEMENT DU SYSTÈME

---

*Pour votre sécurité, déconnectez la borne négative de la batterie avant de commencer l'installation.*

1. **Faire passer le câble d'interface** dans le véhicule de manière à le protéger au maximum. Laisser du mou à chaque extrémité du câble afin de connecter le PSD et l'amplificateur.
2. **Configurer le pontage (Remote Jumper)** situé sur le circuit imprimé. La position de ce jumper détermine si le PSD est contrôlé par l'amplificateur ou séparément. Lorsque le jumper est **installé**, le fil de commande est désactivé et l'amplificateur allume automatiquement le PSD. Lorsque le jumper est **enlevé**, le fil de commande d'allumage est activé et le PSD est contrôlé par un interrupteur séparé. C'est à vous de déterminer quelle méthode d'allumage du PSD convient le mieux à votre application. **NOTE: Le jumper d'allumage doit être enlevé lorsque le PSD est raccordé à un Power 250m<sup>2</sup>, Power 500m ou Power 250m.**
3. Lorsque le **jumper de commande** est enlevé, le fil (**bleu**) de commande d'allumage doit être connecté au fil de commande de l'antenne électrique de l'autoradio. Il est possible d'installer un interrupteur sur ce fil si vous désirez éteindre le PSD.
4. Le **fil (orange)** du dimmer peut être connecté aux feux de position ou à un fil fournissant un 12 volts positif lorsque les phares sont allumés.
5. **Ajustez les gains AVANT d'installer le Punch Status Display (PSD).** Bien que le PSD contrôle le signal de sortie de l'amplificateur il n'est pas conçu pour remplacer un oscilloscope ou tout autre appareil de test spécialisé.



## Commande d'allumage / Dimmer

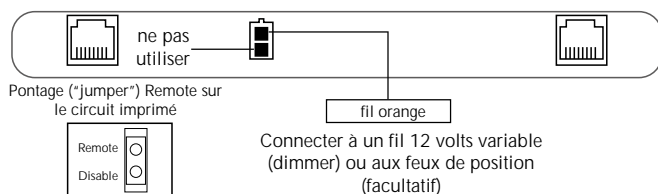

- **La commande d'allumage (fil bleu) n'est pas utilisé** lorsque le jumper est branché.
- **Le dimmer (fil orange) va assombrir les LEDs** lorsqu'il est connecté à un fil variable (dimmer) ou aux feux de position (+12 volts lorsque les phares sont allumés).

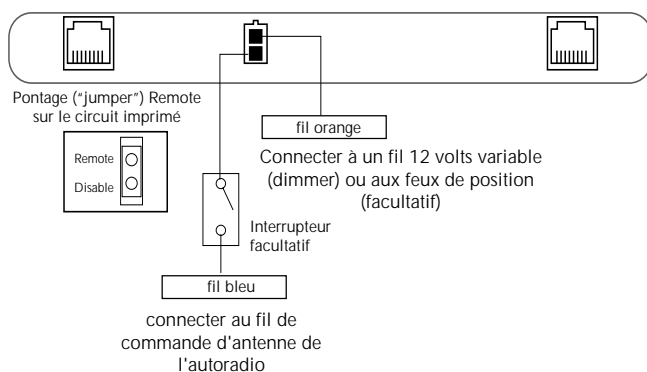

- **Enlever le couvercle** du boîtier pour accéder au jumper de commande en retirant les deux vis.
- **La commande d'allumage (fil bleu) se branche** sur la sortie antenne de l'autoradio lorsque le jumper remote est enlevé.
- **Un interrupteur supplémentaire** peut être branché indépendamment du système audio
- **Le dimmer (fil orange) va assombrir les LEDs** lorsqu'il est connecté à un fil variable (dimmer) ou aux feux de position (+12 volts lorsque les phares sont allumés).

**NOTE: Il faut activer la fonction "remote" et utiliser le fil bleu pour les modèles d'amplis suivants: Power 250m<sup>2</sup>, Power 500m et Power 250m.**

## Configuration du Pontage Mono/Stéréo (Amplis deux)

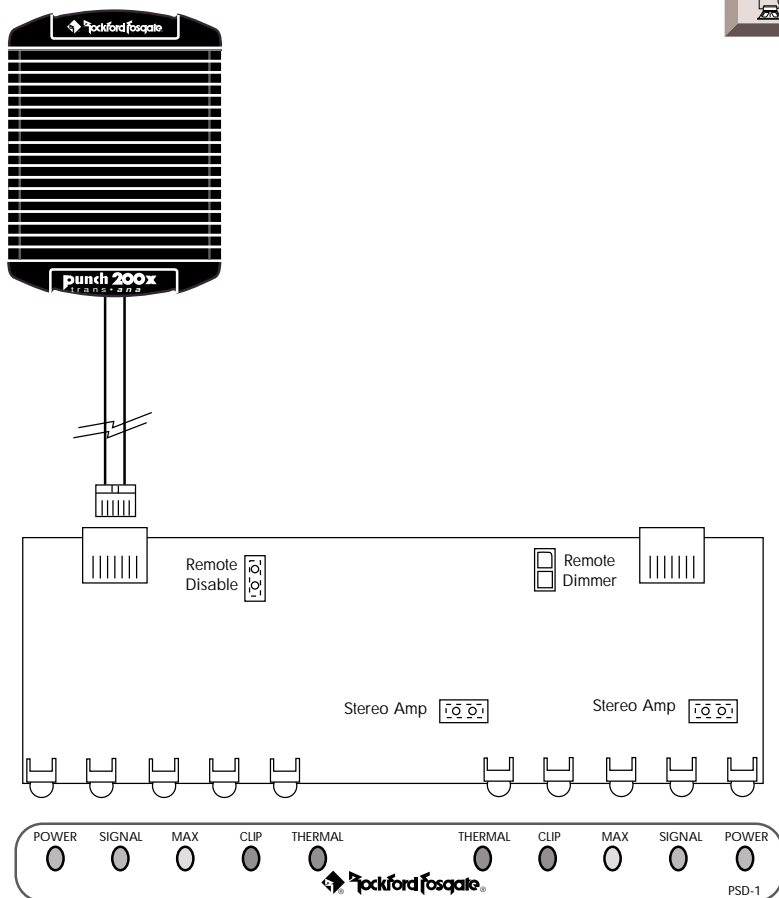

- Les pontages Stéréo/Mono sont *placés*
- L'ampli stéréo se branche sur l'entrée de gauche (*stereo/mono left*)

## Configuration du Pontage Mono/Stéréo (Amplis mono)

(si deux amplis sont utilisés)

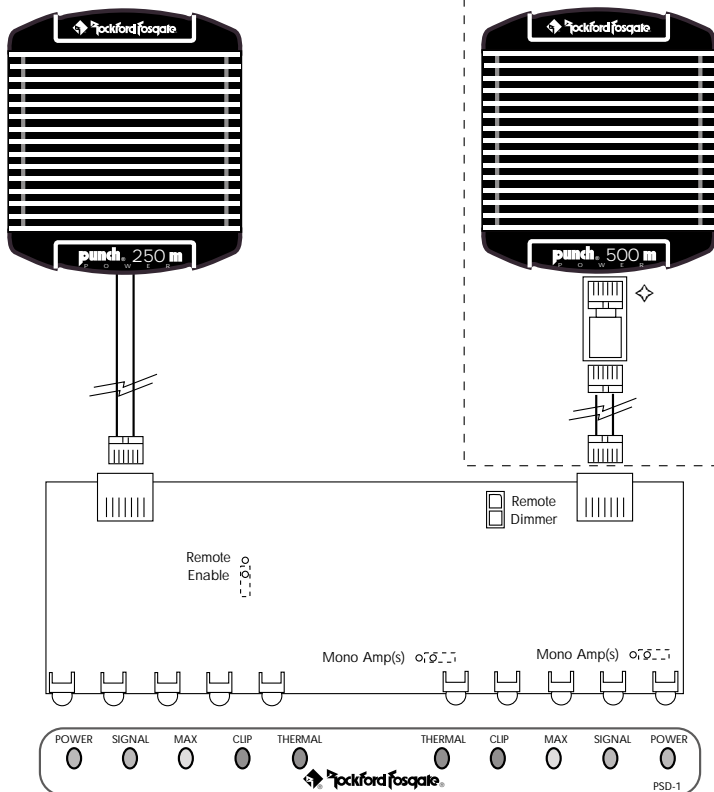

- Les pontages Stéréo/Mono sont *enlevés*
- Un seul ampli mono se branche sur l'entrée de gauche (Stereo/Mono Left)
- L'ampli mono de gauche se branche sur l'entrée de gauche (Stereo/Mono Left)
- L'ampli mono de droite se branche sur l'entrée de droit (Mono Right)

**ATTENTION:** Avec les amplis 250m<sup>2</sup>, Power 250m et Power 500m il faut activer l'entrée remote du PSD

- ◇ Adaptateur utilisé pour le Power 500m seulement
- L'adaptateur pour le Power 500 doit être branche sur le câble de l'interface de données du coté de l'ampli

**NE PAS CONNECTER LE POWER 500 SUR LE PSD SANS L'ADAPTEUR PRECONISE!**

# VERKABELUNG DES SYSTEMS

---

*Zu Ihrer eigenen Sicherheit klemmen Sie bitte das Negativ-Kabel an Ihrer Batterie ab, bevor Sie mit dem Anschließen beginnen*

1. **Ziehen Sie das Daten-Interface Kabel** so durch Ihr Fahrzeug, daß es den bestmöglichen Schutz hat. Achten Sie darauf das es nicht beschädigt werden kann. Lassen Sie an beiden Enden genug Kabel übrig, daß Sie problemlos Endstufe und Display anschließen können.
2. **Einstellen der Remote Jumper** auf der Platinenoberfläche. Die Position der Jumper entscheidet ob das Display über die Endstufen oder separat geschaltet wird. Mit eingestecktem Jumper ist die Remote Leitung ohne Funktion das Display wird mit dem Verstärker geschaltet. Wird der Jumper herausgenommen, ist das Remote Kabel in Funktion das PSD wird dann über einen separaten Schalter aktiviert. Verwenden Sie, die für Sie günstigere Methode.  
**Achtung: Der Remote Jumper muß herausgenommen werden bei einer Power 250m<sup>2</sup>, Power 500m oder Power 250m.**
3. Das **Remote Einschalt-Kabel (blau)** muß angeschlossen werden, wenn der Jumper herausgenommen wurde. Es wird verbunden mit der Schaltleitung des Radios "power Antenne" Sie können einen getrennten Schalter einsetzen um das PSD ein-oder auszuschalten.
4. Das **Dimmer Kabel (orange)** sollte mit der Instrumentenbeleuchtung Ihres Fahrzeuges geschaltet werden, das gibt Ihnen die Möglichkeit die LEDs in der Helligkeit zu regulieren. Oder Sie verwenden +12 Volt Kabel des Abblendlichtes.
5. **Stellen Sie erst die Gains Ihrer Anlage ein bevor Sie das Status Display installieren.** Das Status Display kann das Ausgangs-Signal der Endstufe anzeigen, es dient aber nicht als Ersatz für ein Oszilloscope oder anderes Testequipment.



## Remote Einschalt-Kabel/Dimmer-Kabel

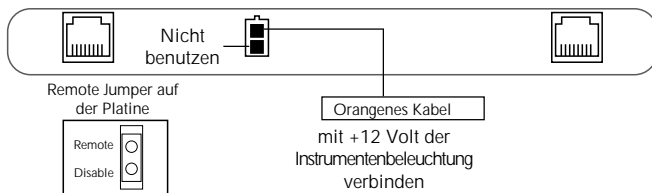

- **Remote Einschalt Kabel** *nicht verwenden (blaues Kabel)* wenn der Remote Jumper auf Disabled steht
- **Dimmer Kabel (Orange)** reguliert die LEDs, wenn das Kabel mit der Instrumentenbeleuchtung Ihres Fahrzeuges verbunden wird (Oder Sie verwenden +12 Volt Kabel des Abblendlichtes.)

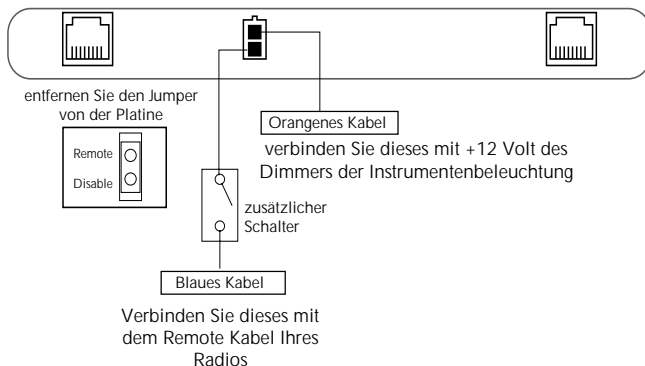

- **Öffnen Sie den Deckel**, um an die Remote Jumper zu gelangen, durch Lösen der beiden Schrauben auf jeder Seite
- **Remote Einschalt-Kabel (blau)** zum Anschluß an das Remote Kabel Ihres Radios, dabei sollte der Jumper auf Enabled stehen
- **Ein zusätzlicher Schalter** kann verwendet werden um das PSD getrennt vom Audio System zu schalten
- **Das Dimmer Kabel (Orange)** bestimmt die Helligkeit der LEDs, wenn es mit dem Dimmer oder der Instrumentenbeleuchtung des Fahrzeuges verbunden wird (oder Sie verwenden +12 Volt Kabel des Abblendlichtes.).

**Achtung:** Bei der Power 250m<sup>2</sup>, Power 250m und Power 500m muß die Stellung Enabled gewählt werden, um ein einwandfreies Funktionieren zu gewähren.



## Jumper Einstellungen (bei 2 Kanal Endstufen)

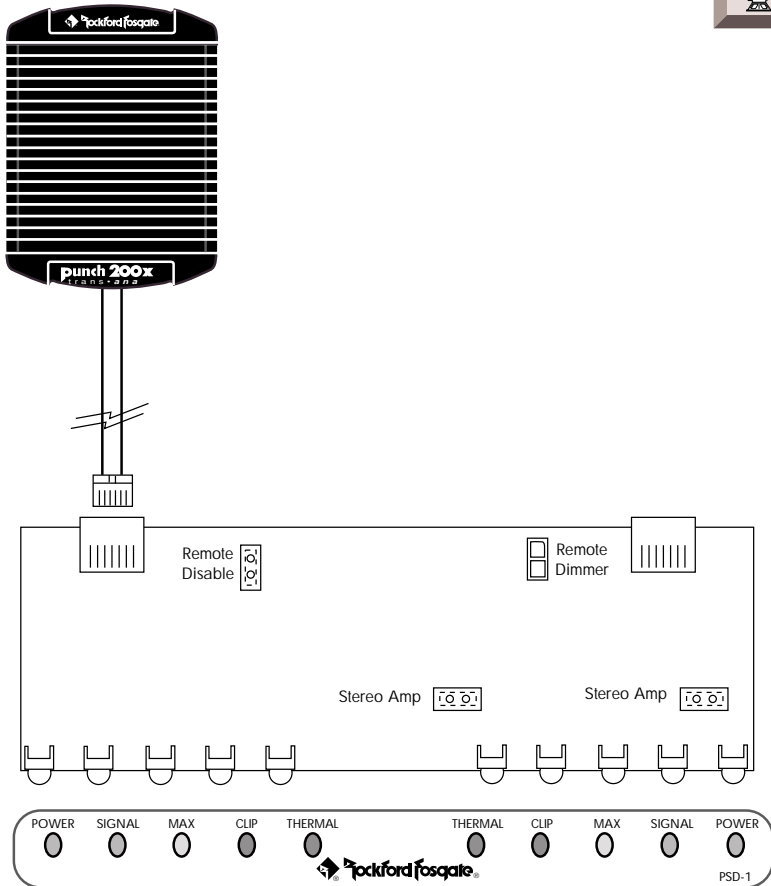

- Bei Stereo- oder Mono- Betrieb müssen die Jumper eingesetzt sein
- Bei 2 Kanal Endstufen im Stereo/Mono Betrieb bitte den linken Eingang verwenden

## Jumper Einstellung (Betrieb von Mono Endstufen)

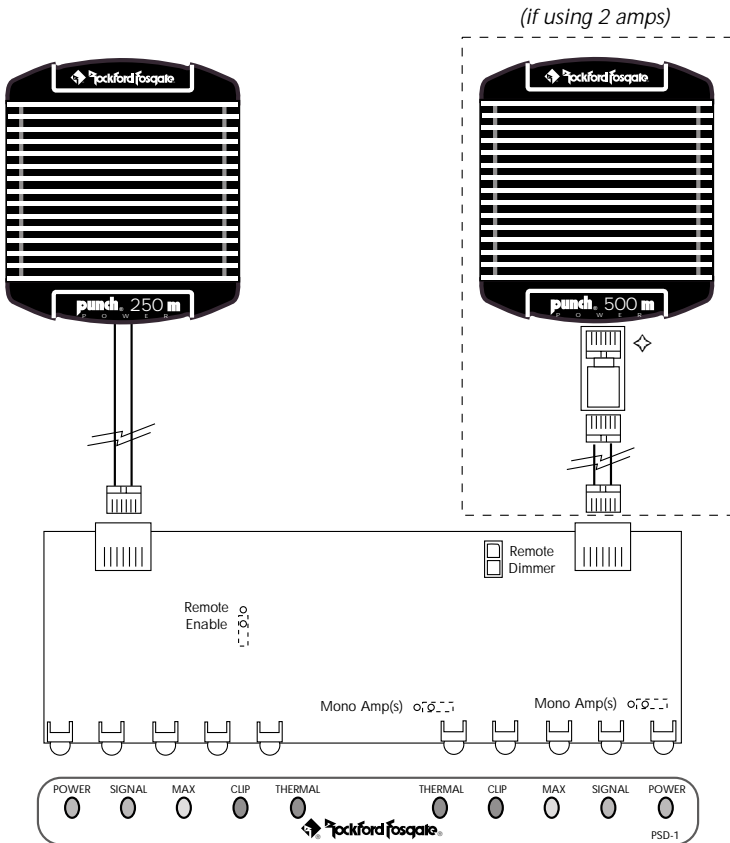

- **Im Stereo/Mono Betrieb** sind die Jumper nicht eingesteckt
  - **Bei einer Mono-Endstufe** im Stereo/Mono Betrieb verwenden Sie den linken Eingang
  - **Beim Betrieb Mono Endstufe links**, den linken Eingang verwenden
  - **Beim Betrieb Mono Endstufe rechts**, den rechten Eingang verwenden
- Achtung: Bei der Power 250m<sup>2</sup>, Power 250m und Power 500m muß die Stellung Enabled gewählt werden, um ein einwandfreies Funktionieren zu gewähren.*
- ❖ **Zum Anschluß der Power 500m benötigen Sie einen Adapter**
  - **Den Power 500m Adapter** müssen Sie verwenden, um einen einwandfreien Betrieb zu garantieren

*Verbinden Sie niemals eine Power 500m and ein PSD ohne den richtigen Adapter. Für Fragen rufen Sie unseren Service an: 04207-5046 Germany, 071-424647 Swiss und 0663-839121 Austria.*

# CABLARE IL SISTEMA

---

*Per motivi di sicurezza, disconnettere il cavo negativo dalla batteria prima di iniziare l'installazione.*

1. **Passare il cavo di interfaccia dati** all'interno dell'auto con il percorso che permette la massima protezione. Lasciare un po' di cavo in eccesso ad ogni estremità del cavo per permettere la connessione all'amplificatore e al PSD.
2. **Configurare i ponticelli del consenso** che sono positionati sul circuito stampato. La posizione di questi ponticelli determina se il PSD sarà controllato dagli amplificatori o meno. Quando il ponticello é installato, il cavo di consenso é disabilitato e gli amplificatori accendono automaticamente il PSD. Quando il ponticello é rimosso, il cavo di consenso é abilitato e il PSD é controllato da un interruttore esterno. Decidete quale configurazione é preferibile per la vostra configurazione. **NOTA: Il ponticello non deve essere installato quando si impiegano il Power 250m<sup>2</sup>, il Power 500m ed il Power 250m.**
3. **Il cavo di consenso dell'accensione** (blu) deve essere collegato (quando il ponticello del consenso é stato rimosso) al cavo id accensione degli amplificatori o dell'antenna elettrica proveniente dall'autoradio É possibile inserire un interruttore supplementare per disabilitare il PSD.
4. **Il cavo dell'illuminazione** (anarnzione) deve essere collegato alle luci di posizione o ad una alimentazione +12 volt presente con le luci accese.
5. **Regolate i livelli del sistema prima di installare il PSD**, che, anche se monitorizza il segnale di uscita dell'amplificatore, non é stato progettato per sostituire oscilloscopi o altri strumenti di misura.



## Cablaggio del consenso ed illuminazione

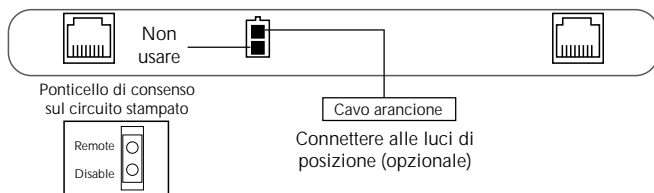

- **Cavo di consenso di accensione (blu)** non impiegato quando il ponticello é inserito
- **Il cavo dell'illuminazione (arancione)** abbassa la luminosità dei LED quando le luci dell'auto sono accese

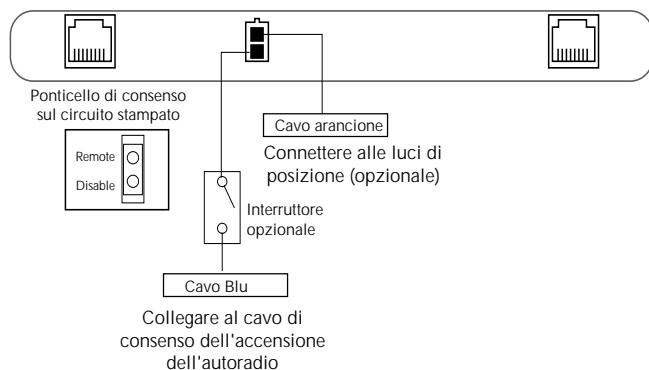

- **Rimuovere il coperchio del PSD** togliendo le due viti per parte per accedere al ponticello di configurazione del consenso di accensione
- **Il cavo di consenso di accensione (blu)** deve essere collegato all'accensione degli amplificatori quando il ponticello é disinserito
- **Un interruttore opzionale** può essere impiegato per spegnere il PSD in modo indipendente dal sistema audio
- **Il cavo dell'illuminazione (arancione)** abbassa la luminosità dei LED quando le luci dell'auto sono accese

**NOTA: Il ponticello non deve essere installato quando si impiegano il Power 250m<sup>2</sup>, Power 250m and Power.**

## Configurazione dei ponticelli (amplificatori 2 canali)

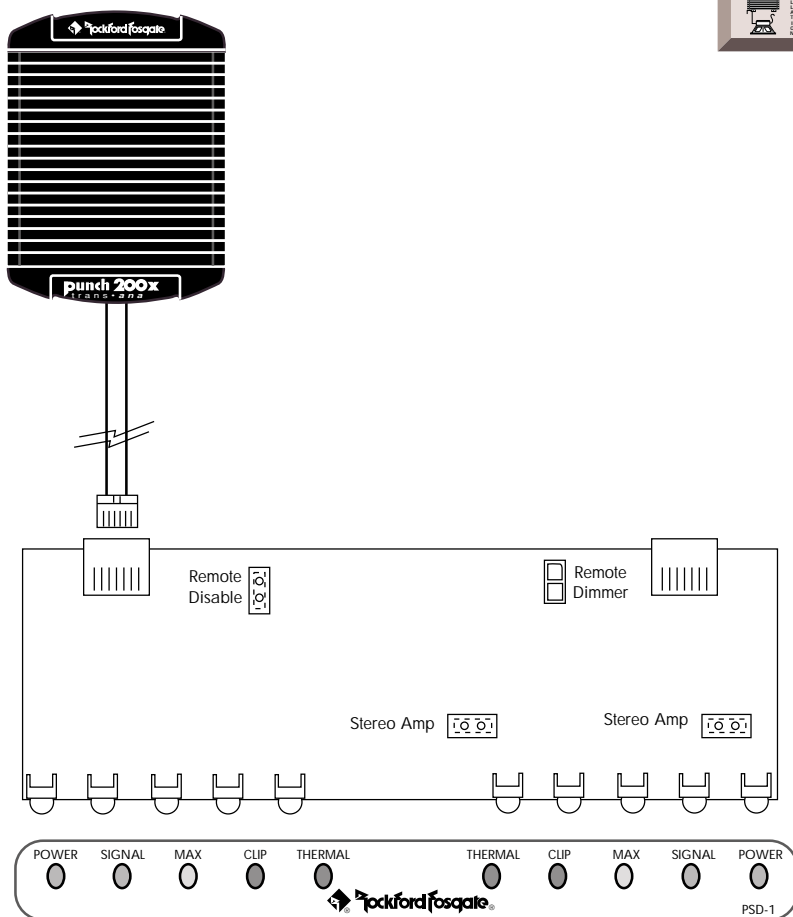

- I ponticelli Stereo/Mono sono *installati* sui pin
- L'amplificatori 2 canali é connesso all'ingresso sinistro stereo/mono

## Configurazione dei ponticelli (amplificatori mono)

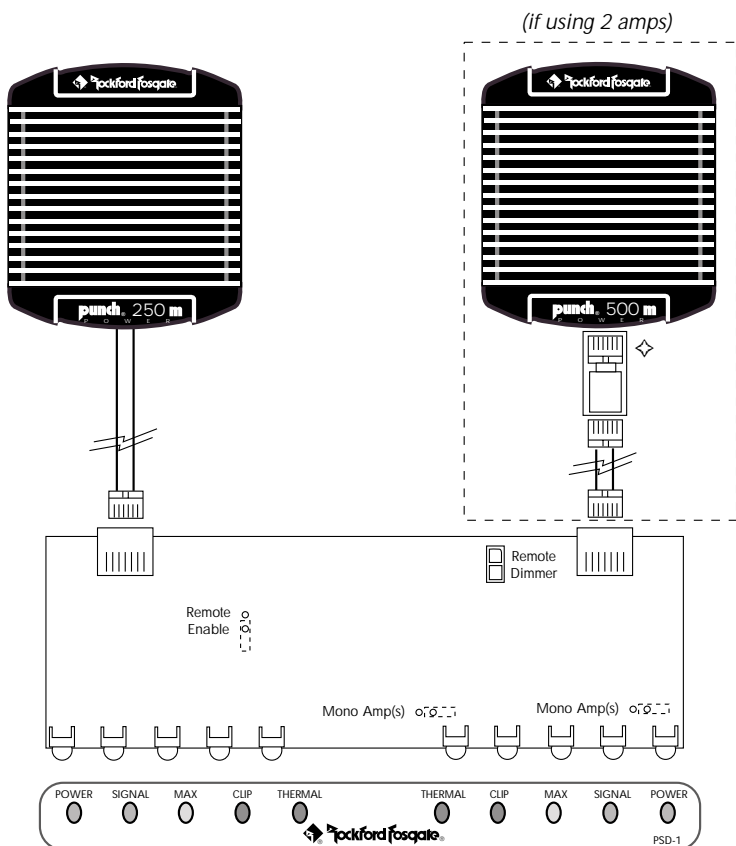

- I ponticelli Stereo/Mono sono *rimossi* dai pin
- L'**amplificatore mono singolo** è collegato all'ingresso sinistro stereo/mono
- L'**amplificatore mono sinistro** è collegato all'ingresso stereo/mono sinistro
- L'**amplificatore mono destro** è collegato all'ingresso destro mono

**NOTA:** Il ponticello non deve essere installato quando si impiegano il Power 250m<sup>2</sup>, Power 250m and Power.

- ◇ L'**adattatore** è impiegato solo con il Power 500m
- L'**adattatore** per il Power 500m deve essere collegato vicino all'amplificatore per il corretto funzionamento

**Non collegate l'amplificatore Power 500m al PSD senza l'apposito adattatore. Contattate il distributore Rockford Fosgate per ulteriori informazioni.**

**Rockford Fosgate**  
Rockford Corporation  
546 South Rockford Drive  
Tempe, Arizona 85281 U.S.A.  
In U.S.A., (602) 967-3565  
In Europe, Fax (49) 4207-801250  
In Japan, Fax (81) 559-79-1265

## Free Manuals Download Website

<http://myh66.com>

<http://usermanuals.us>

<http://www.somanuals.com>

<http://www.4manuals.cc>

<http://www.manual-lib.com>

<http://www.404manual.com>

<http://www.luxmanual.com>

<http://aubethermostatmanual.com>

Golf course search by state

<http://golfingnear.com>

Email search by domain

<http://emailbydomain.com>

Auto manuals search

<http://auto.somanuals.com>

TV manuals search

<http://tv.somanuals.com>