

HP101 Roland Digital Piano

Owner's Manual

Thank you, and congratulations on your choice of the Roland Digital Piano HP101.

Main Features

Piano Sounds with Rich Resonance and Wide-ranging Expressiveness

The stereo sampling piano sound generator realistically reproduces even the sound of the hammers striking the strings, producing the tones of a high-quality concert grand piano. Maximum polyphony of 64 notes ensures that you can use the pedal freely without running out of notes.

Keyboard and Three Pedals Faithfully Reproduce That True Grand Piano Feel

This instrument features a compact progressive hammer action keyboard, which duplicates the touch of a grand piano, with a heavier touch in the lower register, and a lighter touch in the upper register.

The three pedals are designed for good-feeling response, and allows subtle performance nuances to be expressed.

Luxurious Wood-Grain Design

Featuring an elegant, wood-grain cabinet, the compact design of this fine instrument ensures it uses a minimum of space.



In addition to a sliding keyboard lid, the HP101 also features a convenient headphone hook where you can hang your headphones when they are not in use.

Before using this unit, carefully read the sections entitled: "IMPORTANT SAFETY INSTRUCTIONS" (p. 2), "USING THE UNIT SAFELY" (p. 3, 4), and "IMPORTANT NOTES" (p. 5). These sections provide important information concerning the proper operation of the unit. Additionally, in order to feel assured that you have gained a good grasp of every feature provided by your new unit, Owner's manual should be read in its entirety. The manual should be saved and kept on hand as a convenient reference.

Copyright © 2004 ROLAND CORPORATION

All rights reserved. No part of this publication may be reproduced in any form without the written permission of ROLAND CORPORATION.

WARNING: To reduce the risk of fire or electric shock, do not expose this apparatus to rain or moisture.

	CAUTION RISK OF ELECTRIC SHOCK DO NOT OPEN	
ATTENTION: RISQUE DE CHOC ELECTRIQUE NE PAS OUVRIR		
CAUTION: TO REDUCE THE RISK OF ELECTRIC SHOCK, DO NOT REMOVE COVER (OR BACK). NO USER-SERVICEABLE PARTS INSIDE. REFER SERVICING TO QUALIFIED SERVICE PERSONNEL.		



The lightning flash with arrowhead symbol, within an equilateral triangle, is intended to alert the user to the presence of uninsulated "dangerous voltage" within the product's enclosure that may be of sufficient magnitude to constitute a risk of electric shock to persons.



The exclamation point within an equilateral triangle is intended to alert the user to the presence of important operating and maintenance (servicing) instructions in the literature accompanying the product.

INSTRUCTIONS PERTAINING TO A RISK OF FIRE, ELECTRIC SHOCK, OR INJURY TO PERSONS.

IMPORTANT SAFETY INSTRUCTIONS SAVE THESE INSTRUCTIONS

WARNING - When using electric products, basic precautions should always be followed, including the following:

1. Read these instructions.
2. Keep these instructions.
3. Heed all warnings.
4. Follow all instructions.
5. Do not use this apparatus near water.
6. Clean only with a dry cloth.
7. Do not block any of the ventilation openings. Install in accordance with the manufacturers instructions.
8. Do not install near any heat sources such as radiators, heat registers, stoves, or other apparatus (including amplifiers) that produce heat.
9. Do not defeat the safety purpose of the polarized or grounding-type plug. A polarized plug has two blades with one wider than the other. A grounding type plug has two blades and a third grounding prong. The wide blade or the third prong are provided for your safety. If the provided plug does not fit into your outlet, consult an electrician for replacement of the obsolete outlet.
10. Protect the power cord from being walked on or pinched particularly at plugs, convenience receptacles, and the point where they exit from the apparatus.
11. Only use attachments/accessories specified by the manufacturer.
12. Use only with the cart, stand, tripod, bracket, or table specified by the manufacturer, or sold with the apparatus. When a cart is used, use caution when moving the cart/apparatus combination to avoid injury from tip-over.
13. Unplug this apparatus during lightning storms or when unused for long periods of time.
14. Refer all servicing to qualified service personnel. Servicing is required when the apparatus has been damaged in any way, such as power-supply cord or plug is damaged, liquid has been spilled or objects have fallen into the apparatus, the apparatus has been exposed to rain or moisture, does not operate normally, or has been dropped.



For the U.K.

IMPORTANT: THE WIRES IN THIS MAINS LEAD ARE COLOURED IN ACCORDANCE WITH THE FOLLOWING CODE.

BLUE: NEUTRAL
BROWN: LIVE

As the colours of the wires in the mains lead of this apparatus may not correspond with the coloured markings identifying the terminals in your plug, proceed as follows:
The wire which is coloured BLUE must be connected to the terminal which is marked with the letter N or coloured BLACK.
The wire which is coloured BROWN must be connected to the terminal which is marked with the letter L or coloured RED.
Under no circumstances must either of the above wires be connected to the earth terminal of a three pin plug.

USING THE UNIT SAFELY

INSTRUCTIONS FOR THE PREVENTION OF FIRE, ELECTRIC SHOCK, OR INJURY TO PERSONS

About ⚠ WARNING and ⚠ CAUTION Notices

⚠ WARNING	Used for instructions intended to alert the user to the risk of death or severe injury should the unit be used improperly.
⚠ CAUTION	Used for instructions intended to alert the user to the risk of injury or material damage should the unit be used improperly. * Material damage refers to damage or other adverse effects caused with respect to the home and all its furnishings, as well to domestic animals or pets.

About the Symbols

	The ⚠ symbol alerts the user to important instructions or warnings. The specific meaning of the symbol is determined by the design contained within the triangle. In the case of the symbol at left, it is used for general cautions, warnings, or alerts to danger.
	The ⓧ symbol alerts the user to items that must never be carried out (are forbidden). The specific thing that must not be done is indicated by the design contained within the circle. In the case of the symbol at left, it means that the unit must never be disassembled.
	The Ⓢ symbol alerts the user to things that must be carried out. The specific thing that must be done is indicated by the design contained within the circle. In the case of the symbol at left, it means that the power-cord plug must be unplugged from the outlet.

ALWAYS OBSERVE THE FOLLOWING





⚠ WARNING

- Before using this unit, make sure to read the instructions below, and the Owner's Manual.
- Do not open or perform any internal modifications on the unit.
- Do not attempt to repair the unit, or replace parts within it (except when this manual provides specific instructions directing you to do so). Refer all servicing to your retailer, the nearest Roland Service Center, or an authorized Roland distributor, as listed on the "Information" page.
- Never use or store the unit in places that are:
 - Subject to temperature extremes (e.g., direct sunlight in an enclosed vehicle, near a heating duct, on top of heat-generating equipment); or are
 - Damp (e.g., baths, washrooms, on wet floors); or are
 - Humid; or are
 - Exposed to rain; or are
 - Dusty; or are
 - Subject to high levels of vibration.
- Make sure you always have the unit placed so it is level and sure to remain stable. Never place it on stands that could wobble, or on inclined surfaces.
- The unit should be connected to a power supply only of the type described in the operating instructions, or as marked on the rear of unit.
- Use only the attached power-supply cord. Also, the supplied power cord must not be used with any other device.





⚠ WARNING

- Do not excessively twist or bend the power cord, nor place heavy objects on it. Doing so can damage the cord, producing severed elements and short circuits. Damaged cords are fire and shock hazards!
- This unit, either alone or in combination with an amplifier and headphones or speakers, may be capable of producing sound levels that could cause permanent hearing loss. Do not operate for a long period of time at a high volume level, or at a level that is uncomfortable. If you experience any hearing loss or ringing in the ears, you should immediately stop using the unit, and consult an audiologist.
- Do not allow any objects (e.g., flammable material, coins, pins); or liquids of any kind (water, soft drinks, etc.) to penetrate the unit.
- Immediately turn the power off, remove the power cord from the outlet, and request servicing by your retailer, the nearest Roland Service Center, or an authorized Roland distributor, as listed on the "Information" page when:
 - The power-supply cord, or the plug has been damaged; or
 - If smoke or unusual odor occurs
 - Objects have fallen into, or liquid has been spilled onto the unit; or
 - The unit has been exposed to rain (or otherwise has become wet); or
 - The unit does not appear to operate normally or exhibits a marked change in performance.







⚠ WARNING

- In households with small children, an adult should provide supervision until the child is capable of following all the rules essential for the safe operation of the unit. 
- Protect the unit from strong impact. (Do not drop it!) 
- Do not force the unit's power-supply cord to share an outlet with an unreasonable number of other devices. Be especially careful when using extension cords—the total power used by all devices you have connected to the extension cord's outlet must never exceed the power rating (watts/amperes) for the extension cord. Excessive loads can cause the insulation on the cord to heat up and eventually melt through. 
- Before using the unit in a foreign country, consult with your retailer, the nearest Roland Service Center, or an authorized Roland distributor, as listed on the "Information" page. 
- Do not put anything that contains water (e.g., flower vases) on this unit. Also, avoid the use of insecticides, perfumes, alcohol, nail polish, spray cans, etc., near the unit. Swiftly wipe away any liquid that spills on the unit using a dry, soft cloth. 

⚠ CAUTION

- The unit should be located so that its location or position does not interfere with its proper ventilation. 
- Always grasp only the plug on the power-supply cord when plugging into, or unplugging from, an outlet or this unit. 
- At regular intervals, you should unplug the power plug and clean it by using a dry cloth to wipe all dust and other accumulations away from its prongs. Also, disconnect the power plug from the power outlet whenever the unit is to remain unused for an extended period of time. Any accumulation of dust between the power plug and the power outlet can result in poor insulation and lead to fire. 
- Try to prevent cords and cables from becoming entangled. Also, all cords and cables should be placed so they are out of the reach of children. 
- Never climb on top of, nor place heavy objects on the unit. 

⚠ CAUTION

- Never handle the power cord or its plugs with wet hands when plugging into, or unplugging from, an outlet or this unit. 
- If you need to move the instrument, take note of the precautions listed below. At least two persons are required to safely lift and move the unit. It should be handled carefully, all the while keeping it level. Make sure to have a firm grip, to protect yourself from injury and the instrument from damage. 
- Check to make sure the screws securing the unit to the stand have not become loose. Fasten them again securely whenever you notice any loosening.
- Disconnect the power cord.
- Disconnect all cords coming from external devices.
- Raise the adjusters on the stand (p. 10).
- Close the lid.
- Remove the music stand.
- Before cleaning the unit, turn off the power and unplug the power cord from the outlet (p. 8). 
- Whenever you suspect the possibility of lightning in your area, pull the plug on the power cord out of the outlet. 
- Be careful when opening/closing the lid so you do not get your fingers pinched (p. 8). Adult supervision is recommended whenever small children use the unit. 
- Keep any included the music rest's attachment screws, screws of stand, and wing nut in a safe place out of children's reach, so there is no chance of them being swallowed accidentally. 

IMPORTANT NOTES

In addition to the items listed under “IMPORTANT SAFETY INSTRUCTIONS” and “USING THE UNIT SAFELY” on pages 2, 3 and 4, please read and observe the following:

Power Supply

- Do not connect this unit to same electrical outlet that is being used by an electrical appliance that is controlled by an inverter (such as a refrigerator, washing machine, microwave oven, or air conditioner), or that contains a motor. Depending on the way in which the electrical appliance is used, power supply noise may cause this unit to malfunction or may produce audible noise. If it is not practical to use a separate electrical outlet, connect a power supply noise filter between this unit and the electrical outlet.
- Before connecting this unit to other devices, turn off the power to all units. This will help prevent malfunctions and/or damage to speakers or other devices.
- Although the LCD and LEDs are switched off when the POWER switch is switched off, this does not mean that the unit has been completely disconnected from the source of power. If you need to turn off the power completely, first turn off the POWER switch, then unplug the power cord from the power outlet. For this reason, the outlet into which you choose to connect the power cord's plug should be one that is within easy reach.

Placement

- Using the unit near power amplifiers (or other equipment containing large power transformers) may induce hum. To alleviate the problem, change the orientation of this unit; or move it farther away from the source of interference.
- This device may interfere with radio and television reception. Do not use this device in the vicinity of such receivers.
- Noise may be produced if wireless communications devices, such as cell phones, are operated in the vicinity of this unit. Such noise could occur when receiving or initiating a call, or while conversing. Should you experience such problems, you should relocate such wireless devices so they are at a greater distance from this unit, or switch them off.
- Do not expose the unit to direct sunlight, place it near devices that radiate heat, leave it inside an enclosed vehicle, or otherwise subject it to temperature extremes. Excessive heat can deform or discolor the unit.
- When moved from one location to another where the temperature and/or humidity is very different, water droplets (condensation) may form inside the unit. Damage or malfunction may result if you attempt to use the unit in this condition. Therefore, before using the unit, you must allow it to stand for several hours, until the condensation has completely evaporated.
- Do not allow rubber, vinyl, or similar materials to remain on the unit for long periods of time. Such objects can discolor or otherwise harmfully affect the finish.
- Do not allow objects to remain on top of the keyboard. This can be the cause of malfunction, such as keys ceasing to produce sound.
- Do not paste stickers, decals, or the like to this instrument. Peeling such matter off the instrument may damage the exterior finish.

Maintenance

- To clean the unit, use a dry, soft cloth; or one that is slightly dampened. Try to wipe the entire surface using an equal amount of strength, moving the cloth along with the grain of the wood. Rubbing too hard in the same area can damage the finish.
- Never use benzine, thinners, alcohol or solvents of any kind, to avoid the possibility of discoloration and/or deformation.
- The pedals of this unit are made of brass. Brass eventually darkens as the result of the natural oxidization process. If the brass becomes tarnished, polish it using commercially available metal polisher.

Additional Precautions

- Unfortunately, it may be impossible to restore the contents of data that was stored in the unit's memory once it has been lost. Roland Corporation assumes no liability concerning such loss of data.
- Use a reasonable amount of care when using the unit's buttons, sliders, or other controls; and when using its jacks and connectors. Rough handling can lead to malfunctions.
- When connecting / disconnecting all cables, grasp the connector itself—never pull on the cable. This way you will avoid causing shorts, or damage to the cable's internal elements.
- A small amount of heat will radiate from the unit during normal operation.
- To avoid disturbing your neighbors, try to keep the unit's volume at reasonable levels. You may prefer to use headphones, so you do not need to be concerned about those around you (especially when it is late at night).
- When you need to transport the unit, package it in the box (including padding) that it came in, if possible. Otherwise, you will need to use equivalent packaging materials.
- Do not apply undue force to the music stand while it is in use.
- Use a cable from Roland to make the connection. If using some other make of connection cable, please note the following precautions.
- Before opening or closing the keyboard lid, always make sure that no pets or other small animals are located on top of the instrument (in particular, they should be kept away from the keyboard and its lid). Otherwise, due to the structural design of this instrument, small pets or other animals could end up getting trapped inside it. If such a situation is encountered, you must immediately switch off the power and disconnect the power cord from the outlet. You should then consult with the retailer from whom the instrument was purchased, or contact the nearest Roland Service Center.
- Some connection cables contain resistors. Do not use cables that incorporate resistors for connecting to this unit. The use of such cables can cause the sound level to be extremely low, or impossible to hear. For information on cable specifications, contact the manufacturer of the cable.

Contents

USING THE UNIT SAFELY	3	Chapter 4. Connecting External Devices	25
IMPORTANT NOTES	5	Connecting to Audio Equipment.....	25
Panel Descriptions.....	7	Connecting to a Computer.....	25
Control Panel	7	Connecting MIDI Devices.....	26
Rear Panel.....	7	What's MIDI?	26
Before You Start Playing	8	MIDI Send Channel Settings	26
Connecting the Pedal Cable.....	8	Switching Local Control On and Off.....	27
Connecting the Power Cord	8	Appendices	
Opening/Closing the Lid	8	Tone List	28
Setting Up the Music Rest.....	8	Easy Operation List.....	29
Connecting Headphones.....	9	Internal Song List	30
Using the Headphone Hook.....	9	Troubleshooting	32
Turning the Power On and Off	9	MIDI Implementation Chart.....	33
Adjusting the Sound's Volume	9	Main Specifications	34
About the Pedals	10	Index	35
About the Adjuster	10		
Chapter 1. Enjoying the Internal Songs	11		
Listening to Internal Songs	11		
Selecting the Song to Play Back.....	11		
Chapter 2. Performance.....	12		
Performing with a Variety of Sounds	12		
Applying Effects to the Sound	13		
Adding Reverberation to the Sound (Reverb)	13		
Changing the Depth of the Reverb Effect.....	13		
Adjusting the Keyboard Touch (Key Touch).....	14		
Transposing the Key of the Keyboard (Transpose).....	15		
Playing Two Sounds Together (Dual Play).....	16		
Adjusting the Volume Balance in Dual Play (Dual Balance).....	16		
Using Metronome	17		
Sounding the Metronome	17		
Changing the Beat of Metronome.....	18		
Changing the Metronome Tempo	18		
Changing the Metronome Volume.....	19		
Splitting the Keyboard Into Two Sections for Four-Hand Performances (Twin Piano Mode).....	20		
Chapter 3. Changing Various Settings.....	21		
Tuning to Other Instruments' Pitches (Master Tuning).....	21		
Lowering/ Raising the Standard Pitch	21		
Setting the Standard Pitch to 440.0 Hz.....	21		
Setting the Standard Pitch to 442.0 Hz.....	21		
Changing the Temperament.....	22		
Setting the Tonic.....	22		
Changing the Damper Pedal's Resonance.....	23		
Setting the Tuning Curve (Stretch Tuning).....	23		
Disabling Everything Except Piano Play (Panel Lock).....	24		
Using the V-LINK function	24		

Panel Descriptions

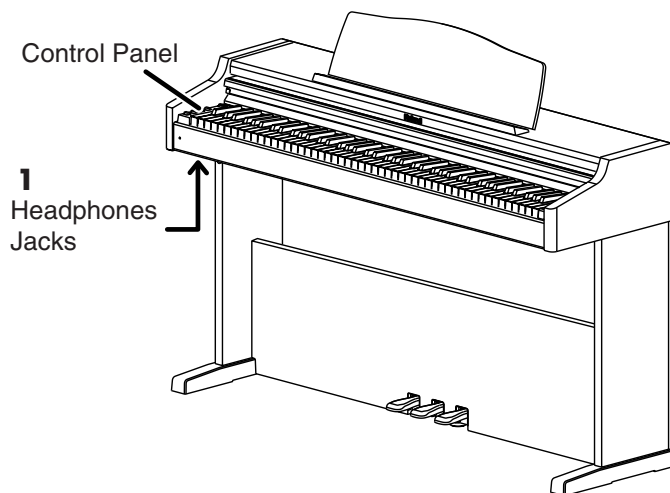

1 Headphones jacks

A set of headphones can be connected here (p. 9).

2 Pedal jack

Connect the pedal cable to this jack (p. 8).

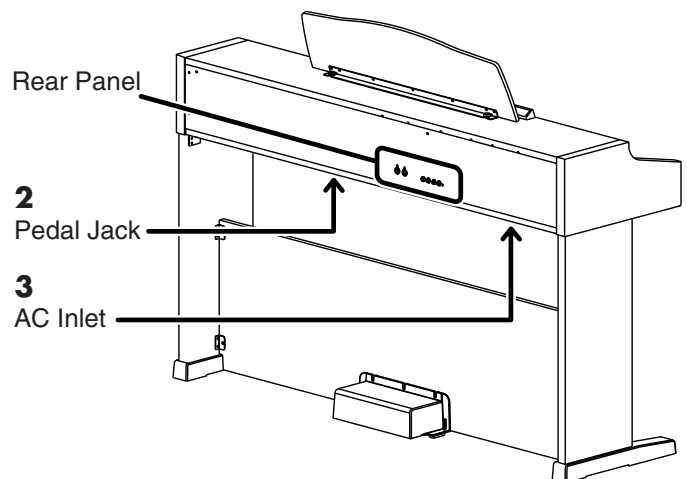

3 AC inlet

Connect the supplied power cord here (p. 8).

Control Panel

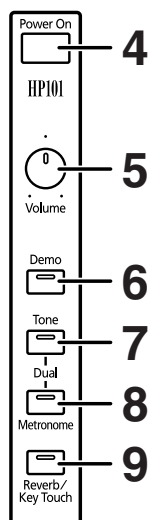

4 [Power On] switch

Turns the power on/off (p. 9).

5 [Volume] knob

Adjusts the overall volume level (p. 9).

6 [Demo] button

Plays the internal songs (p. 11).

7 [Tone] button

Used to choose the tone played by the keyboard (p. 12).

8 [Metronome] button

Turns the metronome on/off (p. 17).

9 [Reverb/Key Touch] button

Adds reverberation to the sound (p. 13).

Modifies the playing feel of the keyboard (p. 14).

Rear Panel

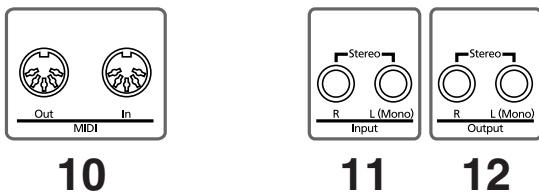

10 MIDI Out/In connectors

Connect to external MIDI devices to exchange performance data (p. 26).

11 Input jacks

These jacks can be connected to another sound generating device or an audio device, so that the sound of that device will be output from the HP101's speakers (p. 25).

12 Output jacks

Allows you to output the piano's sound to sound reinforcement equipment to obtain a more powerful sound. These can also be connected to a tape recorder or other recording device to record a performance (p. 25).

Before You Start Playing

Connecting the Pedal Cable

Connect the pedal cable to the Pedal jack on the bottom panel of the instrument, at the rear.

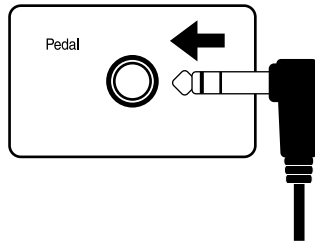

Connecting the Power Cord

1. Insert the included power cord into the AC inlet on the bottom panel of the instrument, at the rear.
2. Plug the power cord into a power outlet.

NOTE

Be sure to use the supplied power cord.

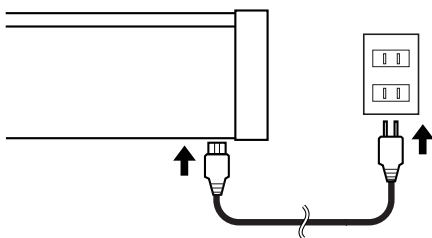

Opening/Closing the Lid

To open the lid, use both hands to lift it lightly, and slide it away from yourself.

To close the lid, pull it gently toward yourself, and lower it softly after it has been fully extended.

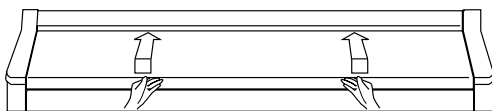

NOTE

When opening and closing the lid, be careful not to let your fingers get caught. If small children will be using the HP101, adult supervision should be provided.

NOTE

If you need to move the piano, make sure the lid is closed first to prevent accidents.

Setting Up the Music Rest

1. Insert the included music rest attachment screws into the screw holes on top of the HP101, and tighten the screws slightly.

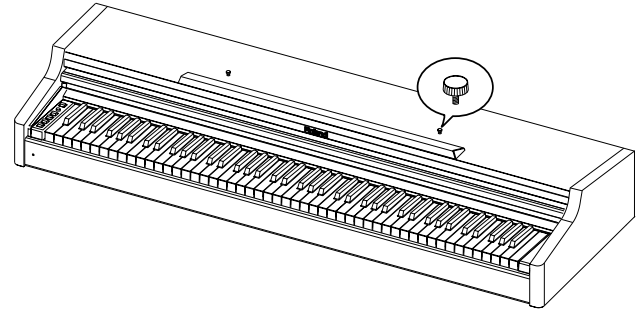

2. Put the music rest between the screws and the HP101's body.

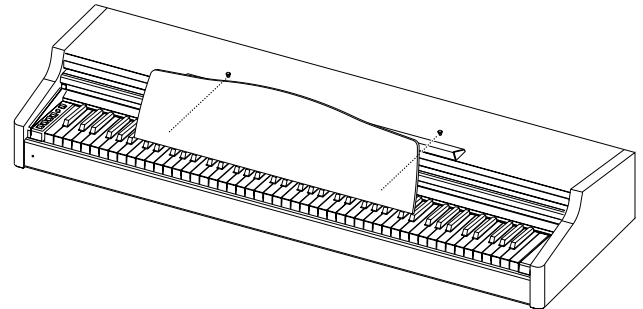

3. While supporting the music rest with one hand, secure it in place by turning the screws.

When attaching the music rest, support it firmly with one hand to make sure that you don't drop it. Be careful, so you don't get your fingers pinched.

4. To remove the music rest, support it with one hand while loosening the screws.

After removing the music rest, don't forget to retighten the screws.

NOTE

Do not apply excessive force to the installed music rest.

NOTE

Be sure to use the supplied screws for attaching the music rest.

NOTE

Before moving the piano, be sure to remove the music rest to prevent accidents.

Connecting Headphones

The HP101 has two jacks for plugging in headphones. This allows two people to listen through headphones simultaneously, making it very useful for lessons and when performing piano pieces for four hands. Additionally, this allows you to play without having to worry about bothering others around you, even at night.

Plug the headphones into the Phones jack located at the bottom left of the piano.

Connecting headphones will automatically mute the sound from the internal speakers.

The headphone volume is adjusted by the [Volume] knob (p. 9) of the HP101.

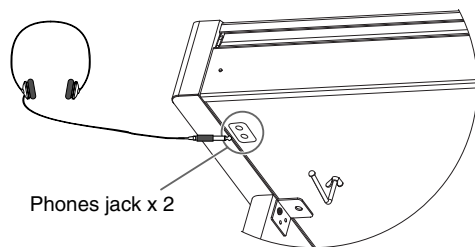

NOTE

Use Stereo headphones.

Some notes on using headphones

- To prevent damage to the cord, handle the headphones only by the headset or the plug.
- Connecting the headphones when the volume of connected equipment is turned up may result in damage to the headphones. Lower the volume on the HP101 before plugging in the headphones.
- Listening at excessively high volume levels will not only damage the headphones, but may also cause hearing loss. Use the headphones at a moderate volume level.

■ Using the Headphone Hook

Whenever you are not using the headphones, you can hang them on the headphone hook at the lower left of the HP101.

Attaching the Headphone Hook

Press and twist the headphone hook included with the HP101 into the hole in the bottom of the HP101 (refer to the figure below). Turn the wing nut of headphone hook to secure the headphone hook.

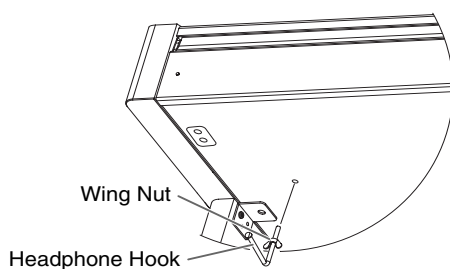

Turning the Power On and Off

NOTE

Once the connections have been completed, turn on power to your various devices in the order specified. By turning on devices in the wrong order, you risk causing malfunction and/or damage to speakers and other devices.

To turn the power on, turn the [Volume] knob all the way down, and then press the [Power On] switch.

The power will turn on, and the Power indicator at the left front of the HP101 will light.

After a few seconds, you will be able to play the keyboard to produce sound.

Use the [Volume] knob to adjust the volume.

NOTE

This unit is equipped with a protection circuit. A brief interval (a few seconds) after power up is required before the unit will operate normally.

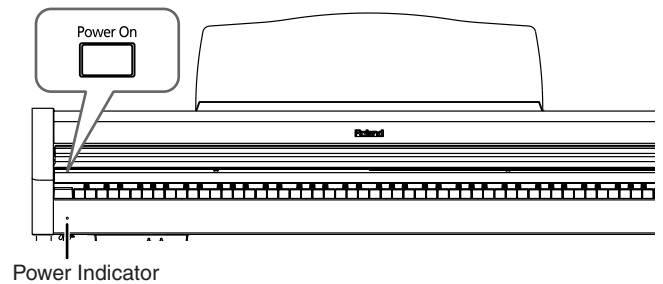

To turn the power off, turn the [Volume] knob all the way to the left, and press the [Power On] switch.

The Power indicator at the left front of the HP101 will go dark, and the power will be turned off.

Adjusting the Sound's Volume

Turn the [Volume] knob to adjust the overall volume.

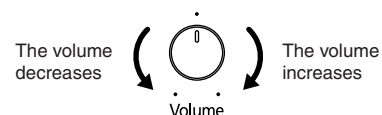

Before You Start Playing

About the Pedals

The pedals have the following functions, and are used mainly for piano performance.

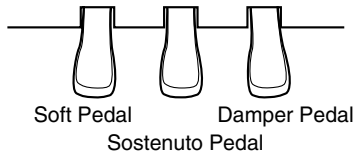

Damper pedal (right pedal)

While this pedal is pressed, notes will be sustained even after you take your fingers off the keys.

On an acoustic piano, holding down the damper pedal will allow the remaining strings to resonate in sympathy with the sounds that you played from the keyboard, adding a rich resonance.

The HP101 simulates this “damper resonance.”



You can change the amount of resonance applied with the damper pedal. Please refer to “Changing the Damper Pedal’s Resonance” (p. 23).

Sostenuto pedal (center pedal)

This pedal sustains only the sounds of the keys that were already played when you pressed the pedal.

Soft pedal (left pedal)

When you hold down this pedal and play the keyboard, the sound will have a softer tone.

About the Adjuster

When you move the HP101 or if you feel that the pedals are unstable, adjust the adjuster located below the pedals as follows.

- Rotate the adjuster to lower it so that it is in firm contact with the floor. If there is a gap between the pedals and the floor, the pedals may be damaged. In particular when placing the instrument on carpet, adjust this so that the pedals firmly contact the floor.

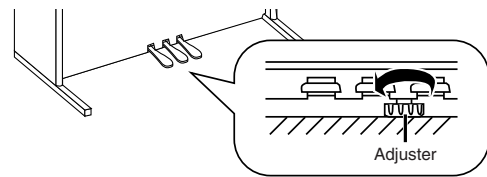

If the adjuster is difficult to turn, have one person lift either the left or right side of the stand to make it easier for another person to turn the adjuster and make the adjustment.



After adjusting the adjuster, press the pedals, and if the front board moves, turn the adjuster further so that it makes firm contact with the floor.



Always readjust the adjuster after moving the piano.

Chapter 1. Enjoying the Internal Songs

Listening to Internal Songs

The HP101 comes with 65 piano songs onboard.
The songs are played back continuously in sequence.



1 Press the [Demo] button, getting its indicator to light.

The demo songs will play back in succession. When the last song has been played, playback will return to the first song and begin again.

Stopping the playback

2 Press the [Demo] button, getting the button to go dark.

Playback will stop.

■ Selecting the Song to Play Back

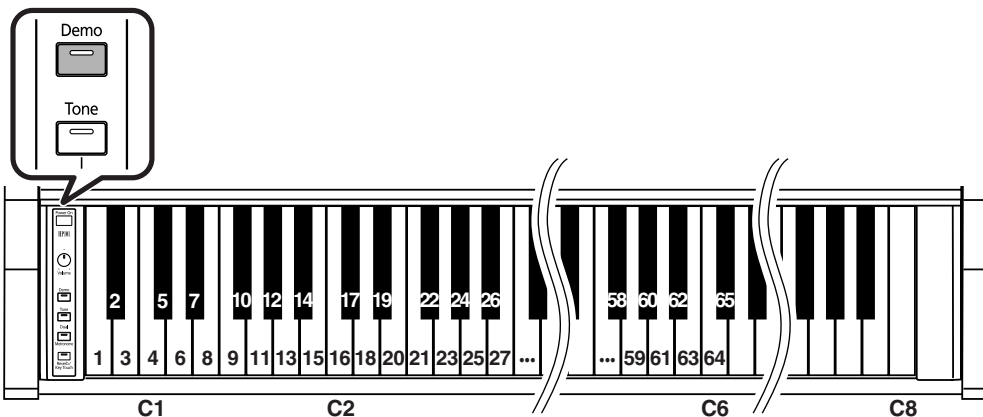

1 While holding down the [Demo] button, press the key that corresponds to the demo song you wish to hear.

The demo songs are assigned to the keys in sequential order, starting with the leftmost key.

The selected song is played back. When the selected song is finished playing, the next song in the sequence starts. The songs are played back until the last one is finished, after which playback continues from the first song.

Stopping the playback

2 Press the [Demo] button, getting the button to go dark.

Playback will stop.

The next time you press the [Demo] button, the stopped song is played back from the beginning.

MEMO

For more details, refer to “Internal Song List” (p. 30).

NOTE

You cannot use the metronome function after you press the [Demo] button and the internal demo songs are playing.

MEMO

When you play back an internal song, the reverb effect will automatically be turned on (the button’s indicator lights).

Chapter 2. Performance

Performing with a Variety of Sounds

The HP101 contains 14 different internal tones.

You can select a tone by holding down the [Tone] button and pressing the key to which the tone is assigned.

The “Grand Piano” tone is selected when the instrument is turned on.

1 While holding down the [Tone] button, press the corresponding key.

Keys with tone assignments: white keys A0–G2

The tone you’ve selected is heard when you finger the keyboard.

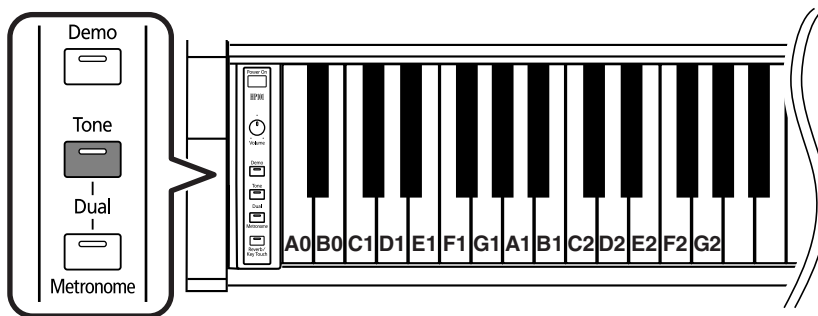

Key Pressed	Tone Number	Tone
A0	1	Grand Piano
B0	2	Mellow Piano
C1	3	Electric Piano1
D1	4	Electric Piano2
E1	5	Vibraphone
F1	6	Harpsichord
G1	7	Coupled Harpsichord
A1	8	Church Organ 1
B1	9	Organ Flute
C2	10	Rotary Organ
D2	11	Church Organ 2
E2	12	Slow Strings
F2	13	Strings
G2	14	Choir

MEMO

For more details, refer to “Tone List” (p. 28).

MEMO

You can switch tones by holding down the [Tone] button and pressing the “C#” or “D#” key. Press the “C#” key to switch to the immediately preceding tone; pressing the “D#” key switches to the immediately following tone.

NOTE

While the [Tone] button is pressed, pressing white keys A0 through G2, “C#” and “D#” won’t result in the production of sound.

Applying Effects to the Sound

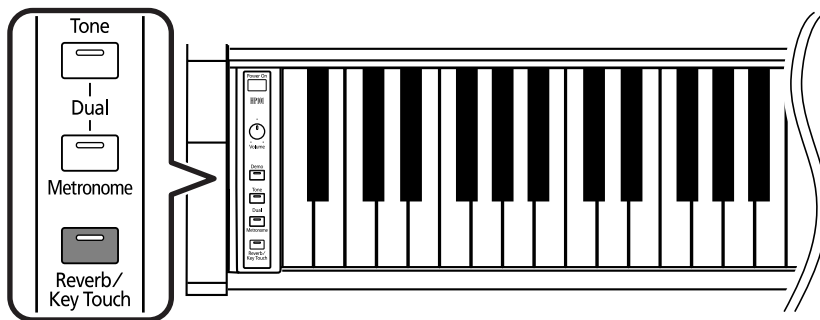

■ Adding Reverberation to the Sound (Reverb)

By applying the reverb effect you can produce a pleasant reverberation, making it sound as though you were performing in a concert hall.

1 Press the [Reverb/Key Touch] button.

The button's indicator will light, and a reverb effect will be applied to the sound.

To cancel the reverb effect, press the [Reverb/Key Touch] button, getting its indicator to go dark.

■ Changing the Depth of the Reverb Effect

The amount (depth) of the reverb effect can be set to any of eight levels.

1 Hold down the [Reverb/Key Touch] button and press the "C#" or "D#" key.

Pressing the "C#" key as you hold down the [Reverb/Key Touch] button reduces the amount of reverb effect applied. Holding down the [Reverb/Key Touch] button and pressing the "D#" key increases the reverb effect.

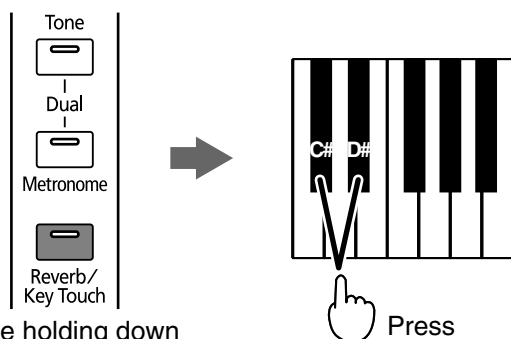

While holding down the [Reverb/Key Touch] buttons...

To restore the depth of the reverb effect at the time the power is turned on, hold down the [Reverb/Key Touch] button and press the "C#" and "D#" keys simultaneously.

MEMO

When you play back an internal song, the reverb effect will automatically be turned on (the button's indicator lights).

MEMO

You can change the Depth of the Reverb Effect by pressing any "C#" or "D#" key.

Adjusting the Keyboard Touch (Key Touch)

You can adjust the touch (playing feel) of the keyboard.

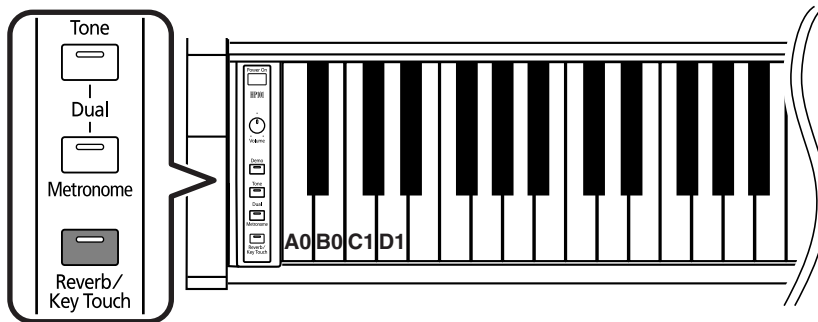

- 1 Hold down the [Reverb/Key Touch] button and press either the "A0," "B0," "C1," or "D1" key.

The feel of the keyboard will change.

The key touch is set to "Medium" when the instrument is turned on.

Key Pressed	Settings	
A0	Light	Fortissimo (ff) can be produced by playing less strongly than usual, making the keyboard feel lighter. This setting makes it easy to play, even for children.
B0	Medium	This allows you to play using the most natural touch. This is the closest to the touch of an acoustic piano.
C1	Heavy	Fortissimo (ff) cannot be produced unless you play more strongly than usual, making the keyboard feel heavier. Dynamic fingering adds even more feeling to what you play.
D1	Fixed	Sounds at a fixed volume, regardless of your keyboard playing strength.

Transposing the Key of the Keyboard (Transpose)

By using the “Transpose function,” you can transpose your performance without changing the notes you play. For example, even if the song is in a difficult key with numerous sharps (#) or flats (b), you can transpose it to a key that is easier for you to play.

When accompanying a vocalist, you can easily transpose the pitch to a range that is comfortable for the singer, while still playing the notes as written (i.e., with the same fingering positions).

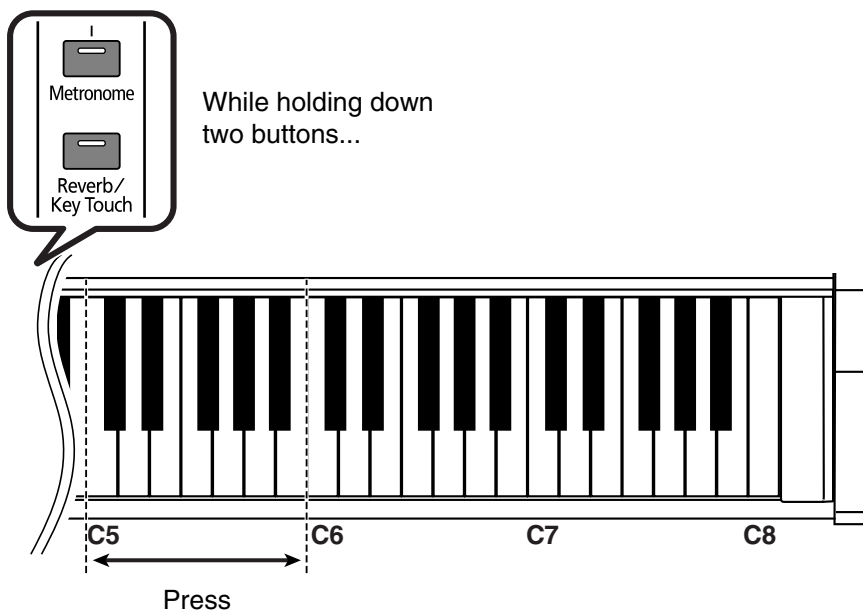

- 1 Hold down the [Metronome] and [Reverb/Key Touch] buttons, and press the key for the note you want to set as the tonic.

Keys for Setting the Transposition: C5–B5

The keyboard will be transposed.

For example, if you want the E pitch to sound when you play the C key, hold down the [Metronome] and [Reverb/Key Touch] buttons and press the E5 key.

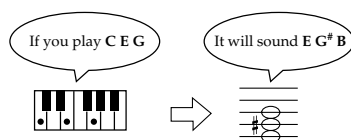

To cancel the transposition, hold down the [Metronome] and [Reverb/Key Touch] buttons and press the “C5” key (transposition 0).



This setting returns to the original value (0) when you turn off the power.

Playing Two Sounds Together (Dual Play)

Simultaneously playing two tones when one key is pressed is called "Dual play."

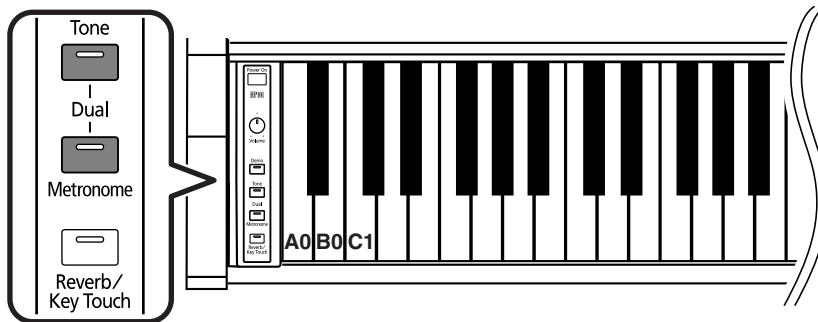

- 1** Hold down the [Tone] button and press a key to which a tone is assigned to select the fundamental tone (p. 12).
- 2** Hold down the [Tone] button and press the [Metronome] button.
Another tone (the Dual Tone) is played together with the tone selected in Step 1.
- 3** To cancel Dual play, press the [Tone] button.

Changing the Dual Tones

- 1** Hold down the [Tone] and [Metronome] buttons, and press either the "A0," "B0," or "C1" key.

Key Pressed	Dual Tone
A0	Slow Strings
B0	Strings
C1	Choir

The Dual Tone is changed.

■ Adjusting the Volume Balance in Dual Play (Dual Balance)

You can change the volume balance between the two layered sounds in Dual play.

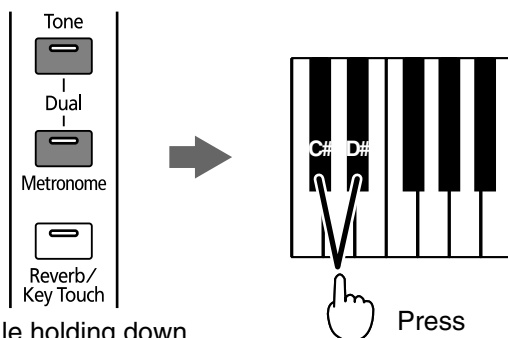

While holding down two buttons...

- 1 Hold down the [Tone] and [Metronome] buttons and press the “C #” or “D #” key.

The volume balance changes.

Hold down the [Tone] and [Metronome] buttons and press the “C #” key to lower the volume of the Dual Tone.

Holding down the [Tone] and [Metronome] buttons and pressing the “D #” key raises the Dual Tone volume.

To return to the original volume balance, hold down the [Tone] and [Metronome] buttons and press both the “C #” and “D #” keys simultaneously.



You can change the Dual Balance by pressing any “C #” or “D #” key.

Using Metronome

■ Sounding the Metronome

The HP101 features a built-in metronome.

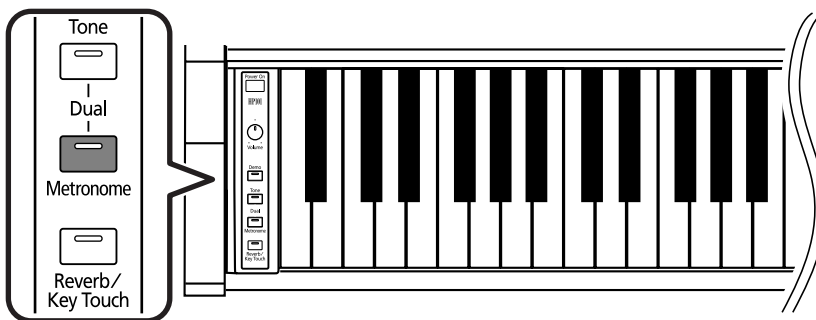

- 1 Press the [Metronome] button, getting its indicator to light.

The metronome will sound.

The button flashes in red and green in time with the beat selected at that time. The button lights in red on the downbeats, and in green on weak beats.

Stopping the metronome

- 2 Once again press the [Metronome] button, getting the button to go dark.

The metronome will stop.



The beat is set to “weak beats only” when the power is turned on. When the beat is set to “weak beats only,” the [Metronome] button only flashes in green.

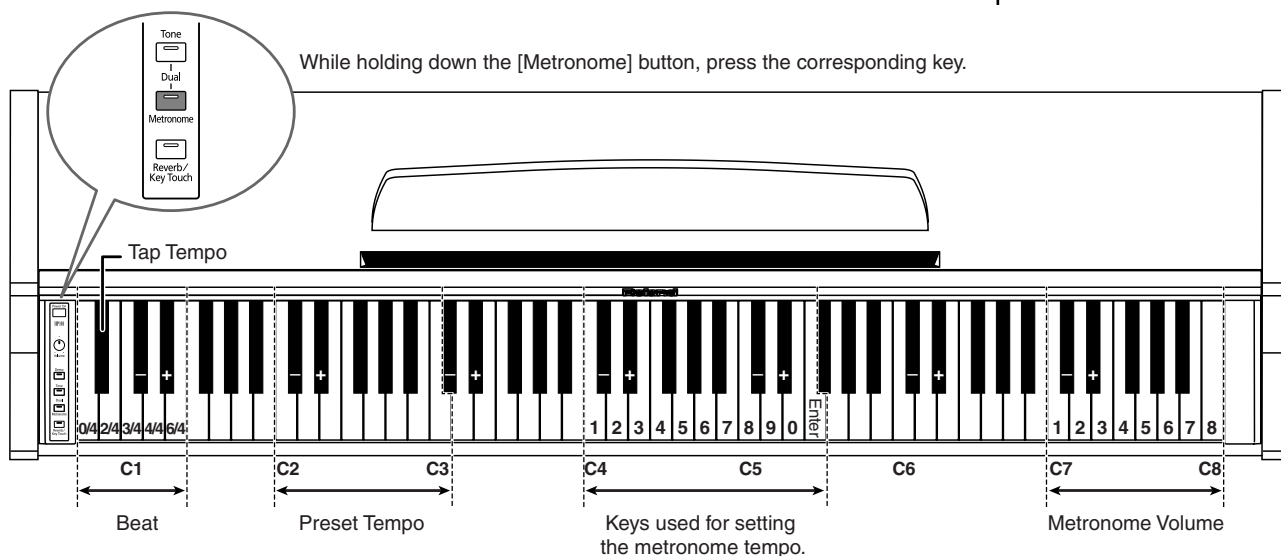

■ Changing the Beat of Metronome

- 1 Hold down the [Metronome] button and press either the "A0," "B0," "C1," "D1," or "E1" key.

Key Pressed	Beat
A0	Only weak beats (0/4)
B0	2/4
C1	3/4
D1	4/4
E1	4/6

■ Changing the Metronome Tempo

Changing the Tempo in Single Beat Increments

- 1 Hold down the [Metronome] button and press the "C#" or "D#" key.

The metronome tempo changes.

Holding down the [Metronome] button and pressing the "C#" key once increases the metronome speed by one increment; continue pressing for consecutive increases.

Holding down the [Metronome] button and pressing the "D#" key once decreases the metronome speed by one increment; continue pressing for consecutive decreases.

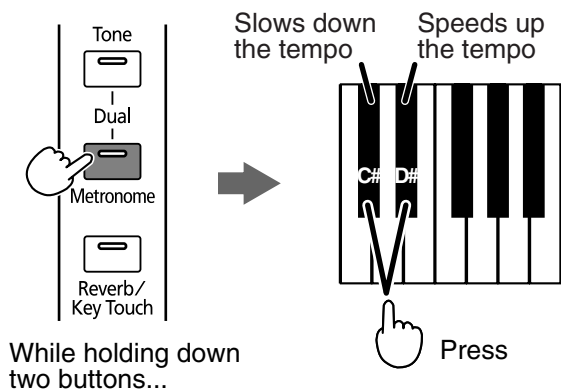

You can change the tempo by pressing any "C#" or "D#" key.

Selecting the Preset Tempo

- 1 Hold down the [Metronome] button and press the white keys in the “C2” to “C3” range.

The metronome tempo changes.

Key Pressed	C2	D2	E2	F2	G2	A2	B4	C3
Tempo	60	72	84	96	108	120	138	160

Setting the Tempo Value

- 1 Hold down the [Metronome] button and press the white keys in the “C4” to “E5” range.

The tempo can be adjusted in a range of ♩=20–250.

Key Pressed	C4	D4	E4	F4	G4	A4	B4	C5	D5	E5	F5
Tempo	1	2	3	4	5	6	7	8	9	0	Enter

- 2 Hold down the [Metronome] button and press the “F5” key to set that tempo.

Example: Setting the Tempo to ♩ = 130

While holding down the [Metronome] button, press the “C4 (1)” key, the “E4 (3)” key, and the “E5 (0)” key, in that sequence, then press the “F5” key to set the tempo.

Setting the Tempo According to the Interval a Key is Pressed as you Hold Down the [Metronome] Button (Tap Tempo)

You can set the tempo according to the interval a key is pressed as you hold down the [Metronome] button. This function is called “Tap Tempo.” This feature allows you to set the tempo you have in mind quickly and easily, without indicating the tempo numerically.

- 1 Hold down the [Metronome] button and press the “B ♭ 0” key at least twice.

The tempo is set to the interval between presses of the key.

■ Changing the Metronome Volume

The volume of the metronome can be adjusted, with eight volume levels available.

- 1 Hold down the [Metronome] button and press a white key in the “C7” to “C8” range.

Key Pressed	C7	D7	E7	F7	G7	A7	B7	C8
Volume	1	2	3	4	5	6	7	8



This is set to “4” when the instrument is turned on.

Splitting the Keyboard Into Two Sections for Four-Hand Performances (Twin Piano Mode)

You can divide the keyboard into two separate sections, allowing two people to perform in the same registers.

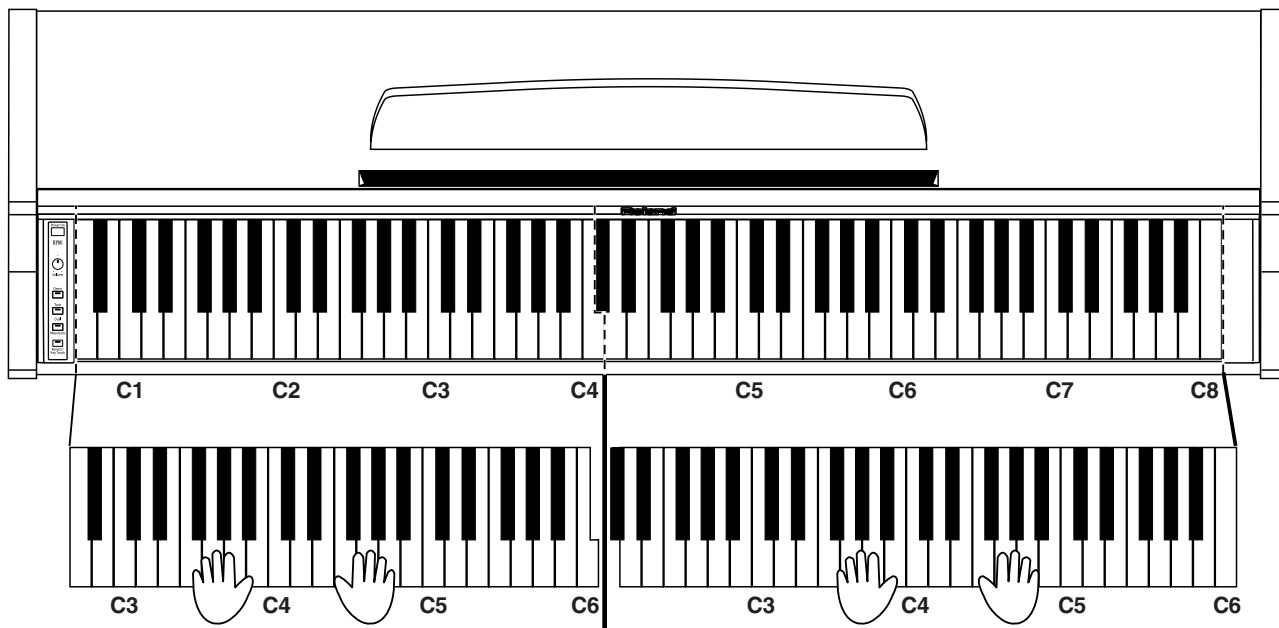

- 1 While holding down the [Tone] button and press the "C8" key.

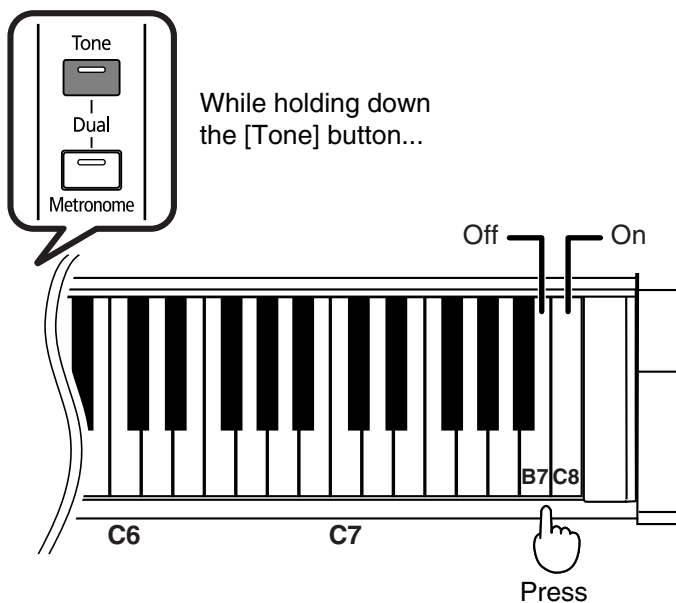

The keyboard is divided into two separate sections, and the pitch changes.

The right pedal now functions as the damper pedal for the right keyboard section, and the left pedal functions as the damper pedal for the left keyboard section.

- 2 To exit the function, hold down the [Tone] button and press the "B7" key.

NOTE

The damper resonance function is not operational in Twin Piano Mode.

Chapter 3. Changing Various Settings

Tuning to Other Instruments' Pitches (Master Tuning)

In situations such as when playing ensemble with other instruments, you can tune the HP101's standard pitch to the pitch of another instrument. The standard pitch generally refers to the pitch of the note that's played when you finger the middle A key. This tuning of all the instruments to a standard pitch is called "tuning."

You can set the standard pitch anywhere in a range of 415.3 Hz to 466.2 Hz.

When the instrument is turned on, the standard pitch is set to "440.0 Hz."

Lowering/ Raising the Standard Pitch

1. While holding down the [Metronome] and [Reverb/Key Touch] buttons, press the "C # 1" note to lower the standard pitch, or the "D # 1" note to raise it.

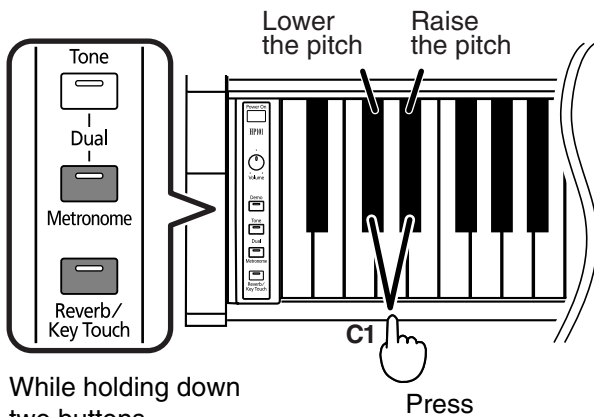

While holding down two buttons...

Press

Each time you press the "C # 1" key, the pitch will fall by 0.1 Hz. If you continue holding the key, the pitch will continue falling.

Each time you press the "D # 1" key, the pitch will rise by 0.1 Hz. If you continue holding the key, the pitch will continue rising.

Setting the Standard Pitch to 440.0 Hz

1. While holding down the [Metronome] and [Reverb/Key Touch] buttons, press the "C1" key on the keyboard.

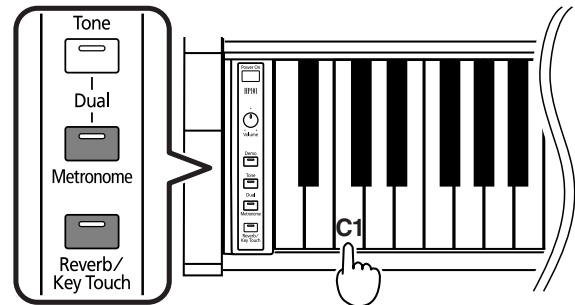

While holding down two buttons...

Press

The standard pitch will be set to 440.0 Hz. This is the most commonly used setting. The A4 (Middle A) key will sound at 440.0 Hz.

Setting the Standard Pitch to 442.0 Hz

1. While holding down the [Metronome] and [Reverb/Key Touch] buttons, press the "D1" key on the keyboard.

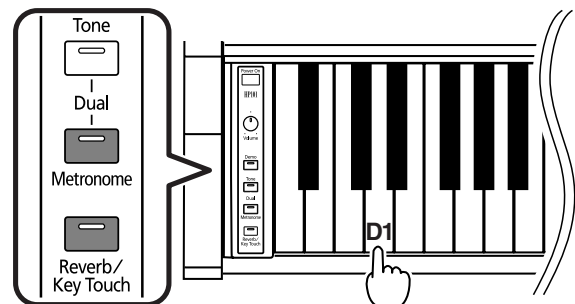

While holding down two buttons...

Press

The standard pitch will be set to 442.0 Hz. This setting is often used for concert pianos. The A4 (Middle A) key will sound at 442.0 Hz.

You can confirm the pitch of A4 by holding down the [Metronome] and [Reverb/Key Touch] buttons and pressing either the A0, B ♭ 0, or B0 key.

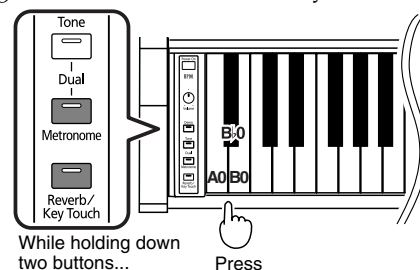

While holding down two buttons...

Press

Chapter 3. Changing Various Settings

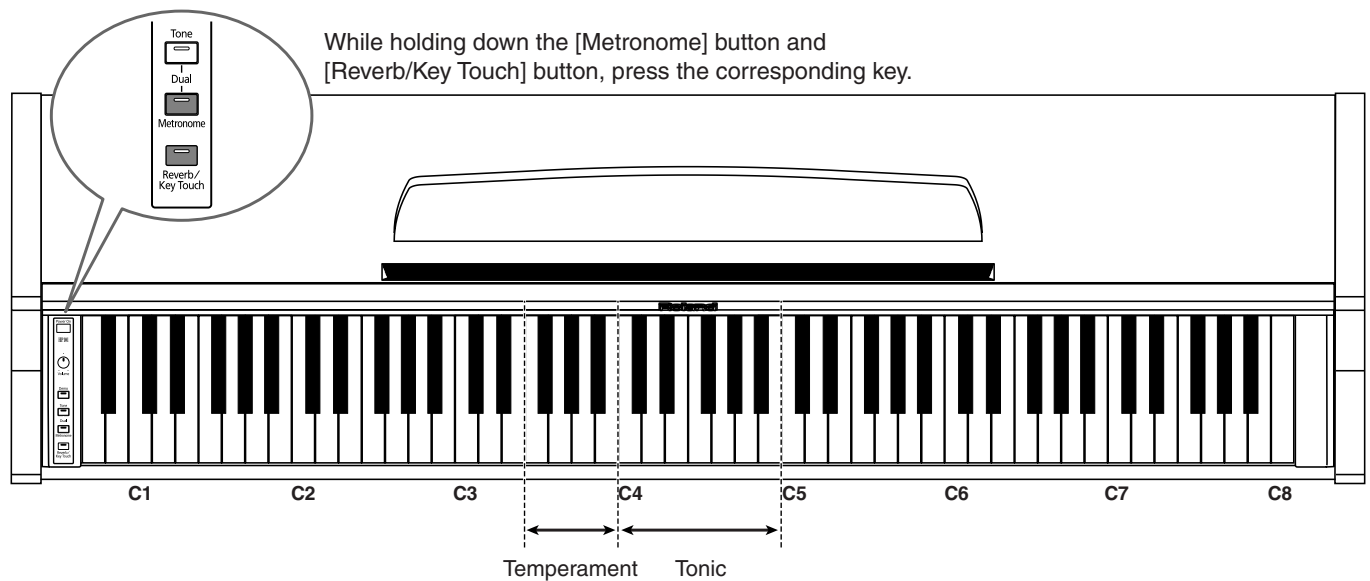

Changing the Temperament

You can play classical styles such as Baroque using historic temperaments (tuning methods).

Today, compositions are generally created with equal temperament in mind and are played using equal temperament. However in past ages of classical music, a variety of temperaments were used. Playing a composition with its original tuning lets you enjoy the sonorities of the chords that the composer originally intended.

This is set to "Equal" when the instrument is turned on.

1. While holding down the [Metronome] and [Reverb/Key Touch] buttons, press the appropriate key (F3–B3) on the keyboard.

You can choose from among the seven temperaments described below.

Key	Temperament	Qualities
F3	Equal	In this tuning, each octave is divided into twelve equal steps. Every interval produces about the same amount of slight dissonance.
F # 3	Pythagorean	This tuning, devised by the philosopher Pythagoras, eliminates dissonance in fourths and fifths. Dissonance is produced by third-interval chords, but melodies are euphonious.
G3	Just Major	This tuning eliminates ambiguities in the fifths and thirds. It is unsuited to playing melodies and cannot be transposed, but is capable of beautiful sonorities.

Key	Temperament	Qualities
G # 3	Just Minor	The Just tunings differ from major and minor keys. You can get the same effect with the minor scale as with the major scale.
A3	Mean Tone	This scale makes some compromises in just intonation, enabling transposition to other keys.
B ♭ 3	Werckmeister	This temperament combines the Mean Tone and Pythagorean tunings. Performances are possible in all keys (first technique, III).
B3	Kirnbeger	This is an improvement of the Mean Tone and Just tunings that provides a high degree of freedom of modulation. Performances are possible in all keys (III).

Setting the Tonic

When playing with tuning other than equal temperament, you need to specify the tonic note for tuning the song to be performed (that is, the note that corresponds to C for a major key or to A for a minor key).

If you choose an equal temperament, there's no need to select a tonic note.

1. While holding down the [Metronome] and [Reverb/Key Touch] buttons, press the tonic (root) of the key (C4–B4).

* When performing in ensemble with other instruments, be aware that depending on the key, there may be some shifting of the pitch. Tune the HP101 to the standard pitch of the other instruments.

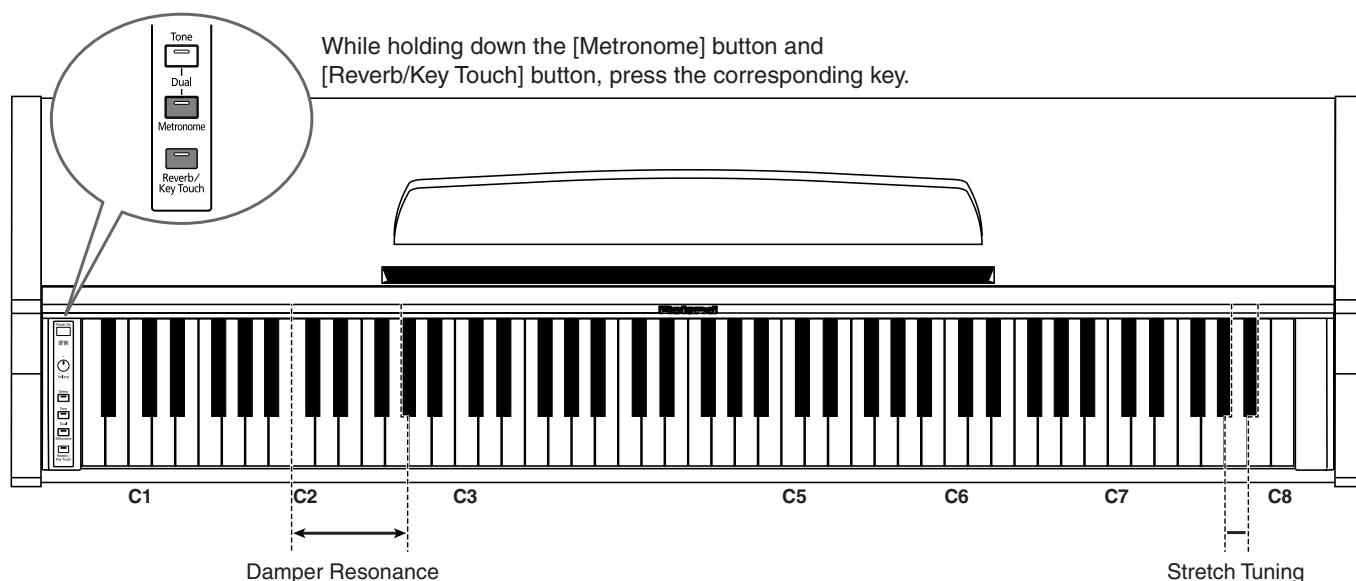

Changing the Damper Pedal's Resonance

On an acoustic piano, depressing the damper pedal makes the notes you play resonate with other strings, adding rich reverberations and fatness to the sound. The damper pedal on the HP101 recreates this resonance (damper resonance) when depressed.

You can select from eight levels of depth for the resonant sound (resonance level).

This is set to "5" when the instrument is turned on.

* This setting is enabled only with the piano tones. You cannot set this for other tones.

1. While holding down the [Metronome] and [Reverb/Key Touch] buttons, press the appropriate key (C2–G2) on the keyboard.

Larger values will produce a deeper effect.

Key	C2	C # 2	D2	E ♭ 2	E2	F2	F # 2	G2
Depth of Effect	1	2	3	4	5	6	7	8

Setting the Tuning Curve (Stretch Tuning)

A piano is generally tuned to a pitch with a lower bass range and a higher treble range than equal temperament. This special tuning method for pianos is called "Stretch Tuning."

→ This effect works only with the piano tones.

Stretch Tuning is set to ON when the instrument is turned on.

1. While holding down the [Metronome] and [Reverb/Key Touch] buttons, the "B ♭ 7" note to turn the setting On, or press the "A7" note to turn the setting Off.

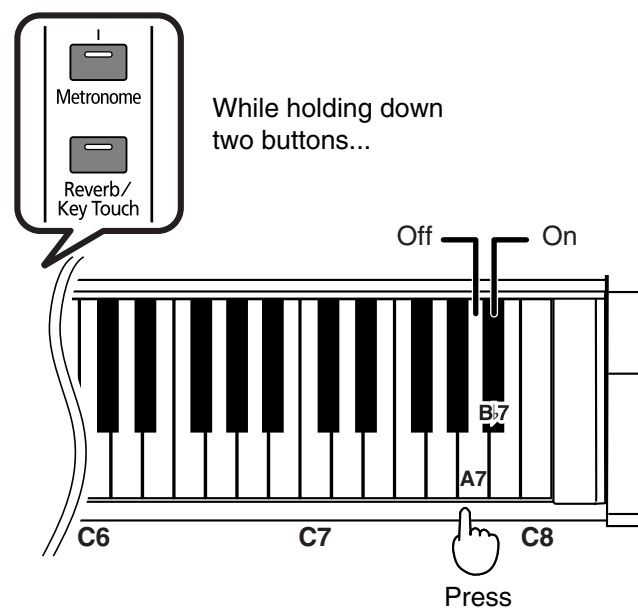

Key	Values	Descriptions
A7	Off	This is the standard tuning curve. This is the right choice when using Dual play (p. 16), or when playing in ensemble with other instruments.
B ♭ 7	On	This tuning curve expands the bass and treble ends somewhat. It is suitable for performances such as piano solos. This setting is in effect when you turn on the power.

Disabling Everything Except Piano Play (Panel Lock)

The "Panel Lock" function locks the HP101 in a state where only piano performance can be used, and all buttons will be disabled. This prevents the settings from being inadvertently modified even if children press the buttons accidentally. In the Panel Lock state, only the grand piano sound can be played.

1. Turn the volume to the minimum, and press the [Power On] switch to turn off the power.
2. Hold down the [Tone] button and press the [Power On] switch to turn on the power.

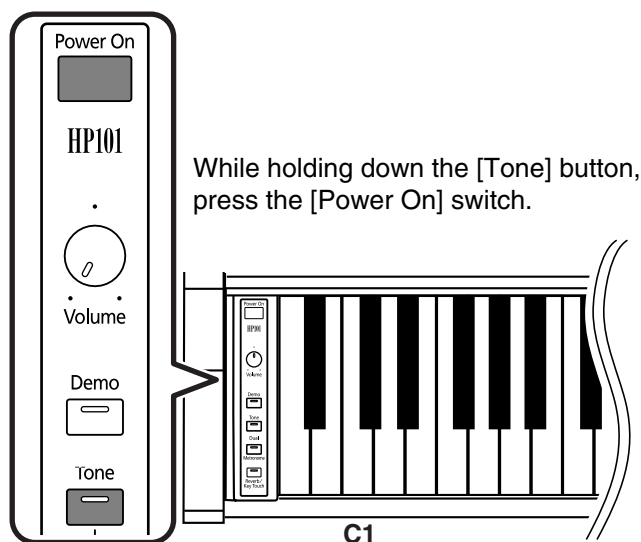

All buttons are disabled.

Adjust the volume.

When you play the keyboard, the grand piano sound will be heard.

To defeat the Panel Lock function, turn the volume down to the minimum, and turn on the power once again.

Using the V-LINK function

Connecting the HP101 to a V-LINK compatible image device allows you to control the images with the HP101.

V-LINK

V-LINK (**V-LINK**™) is a function that allows music and images to be performed together. By using MIDI to connect two or more V-LINK compatible devices, you can easily enjoy a wide range of visual effects that are linked to the expressive elements of a music performance.

* V-LINK (**V-LINK**™) is a trademark of Roland Corporation.

How to Use the V-LINK

V-LINK is set to OFF when the instrument is turned on.

1. While holding down the [Metronome] and [Reverb/Key Touch] buttons, the "G # 7" note to turn the setting On, or press the "G7" note to turn the setting Off.

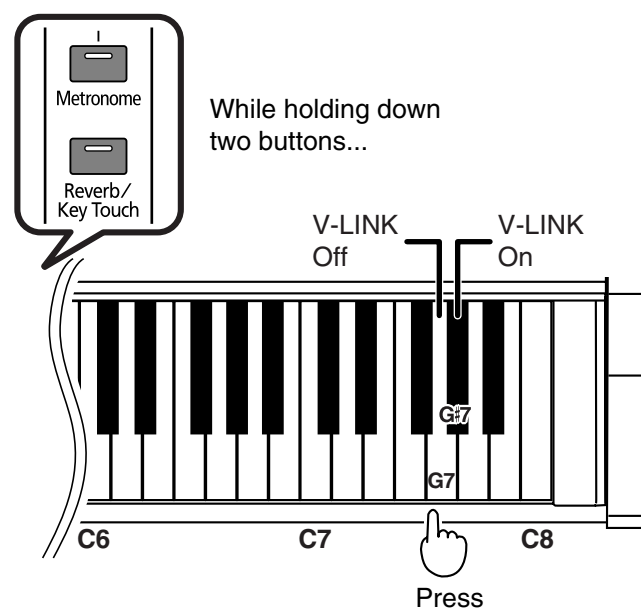

Key	Values	Descriptions
G7	Off	The V-LINK function is switched off.
G # 7	On	The V-LINK function is switched on. You can control images using the twelve keys at the left end of the keyboard.

* While V-LINK is switched on, no sound is produced when you press any of the twelve keys at the left end of the keyboard.

All button indicators light up when the V-LINK function is on.

Chapter 4. Connecting External Devices

Connecting to Audio Equipment

You can connect audio devices to play the sound of the HP101 through the speakers of your audio system, or to record your performance on a tape recorder or other recording device.

When connecting, please use an audio cable with a standard phone plug (sold separately).

Connection Examples

- * To prevent malfunction and/or damage to speakers or other devices, always turn down the volume, and turn off the power on all devices before making any connections.

Playing the sound of the HP101 through the speakers of an audio system/Recording the performance of the HP101 on a recording device

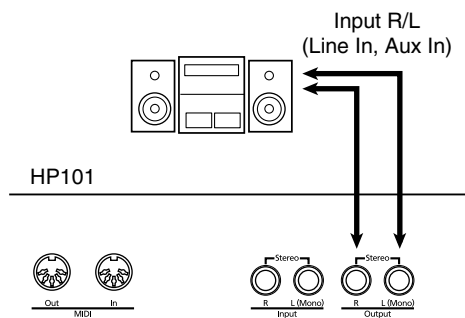

○ Use the following procedure when turning on the power.

1. Turn on the power of the HP101.
2. Turn on the power of the connected device.
3. Adjust the volume of each device.

→ You can adjust the volume of a connected sound module with the HP101.

When Recording HP101 Performances on a Recording Device

4. Start recording with the connected device.
5. Perform on the HP101.
6. When the performance ends, stop recording on the connected equipment.

Playing the sound of an audio device through the speakers of the HP101

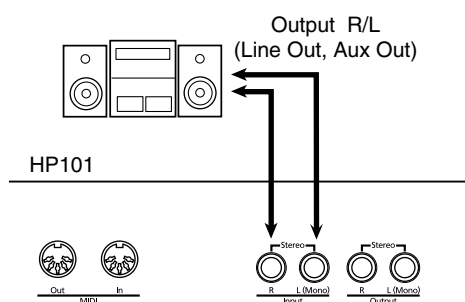

○ Use the following procedure when turning on the power.

1. Turn on the power of the connected device.
2. Turn on the power of the HP101.
3. Adjust the volume of each device.

* You cannot use the HP101 to adjust the volume of the connected sound generating device.

Turning off the power

1. Set the volume of the HP101 and of the connected devices to the minimum position.
2. Turn off the power to the HP101.
3. Turn off the connected equipment.

Connecting to a Computer

You can use a USB MIDI interface cable (sold separately) to connect the HP101 to your computer.

You can connect the HP101 to a computer that has Roland's Visual MT or other sequencer software installed, and then play performances from the software through the HP101.

Connection Examples

* To prevent malfunction and/or damage to speakers or other devices, always turn down the volume, and turn off the power on all devices before making any connections.

* In order to make connections to your computer, you must install "MIDI driver" software on your computer. For details, refer to the owner's manual for your MIDI interface.

Use a USB MIDI interface cable to connect the USB connector of your computer to the MIDI connectors of the HP101.

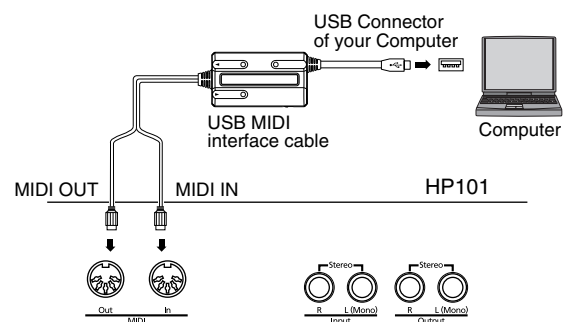

Connecting MIDI Devices

By connecting an external MIDI device and exchanging performance data, you can control the performances on one device from the other. For instance, you can output sound from the other instrument or switch tones on the other instrument.

■ What's MIDI?

MIDI stands for Musical Instrument Digital Interface, an international standard which allows performance information to be communicated among electronic musical instruments and computers.

The HP101 provides MIDI connectors, which allow performance data to be exchanged with external devices. When these connectors are used to connect the HP101 to external devices, an even wider range of possibilities becomes available.

- * A separate publication titled "MIDI Implementation" is also available. It provides complete details concerning the way MIDI has been implemented on this unit. If you should require this publication (such as when you intend to carry out byte-level programming), please contact the nearest Roland Service Center or authorized Roland distributor.

Connection Examples

- * To prevent malfunction and/or damage to speakers or other devices, always turn down the volume, and turn off the power on all devices before making any connections.

Playing the HP101 from a MIDI sequencer/ Recording an HP101 performance on a MIDI sequencer

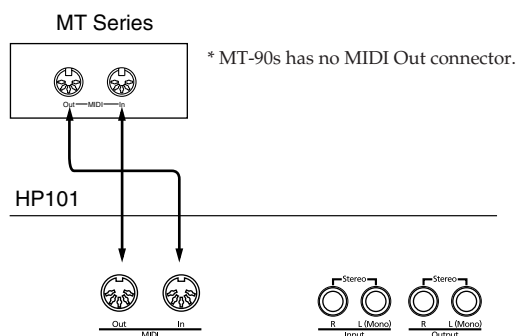

- * Set Local Off if you have connected the HP101 to a MIDI sequencer. Refer to "Switching Local Control On and Off" (p. 27). Also set your MIDI sequencer to MIDI Thru mode (so that messages received at MIDI IN will be re-transmitted without change from MIDI OUT). For details, refer to the owner's manual of your MIDI sequencer.

Perform on the HP101 to play a MIDI sound generator

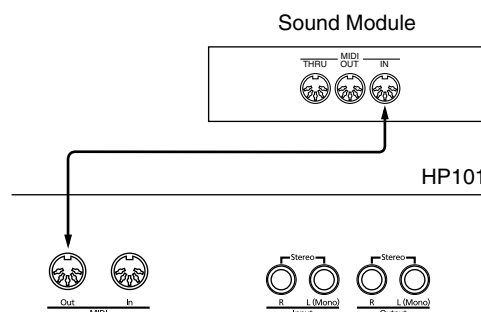

■ MIDI Send Channel Settings

MIDI features sixteen MIDI channels, numbered 1–16. Simply connecting a cable is not enough for communication to take place. The connected devices must be set to use the same MIDI channels. Otherwise, no sound will be produced, and no sounds can be selected.

- * The HP101 receives all channels 1–16.

When the HP101 is turned on, Channel "1" is selected.

1. While holding down the [Metronome] and [Reverb/Key Touch] buttons, press the appropriate key (C6–E ♭ 7) on the keyboard.

The MIDI transmit channel will switch to the number that corresponds to the note you pressed.

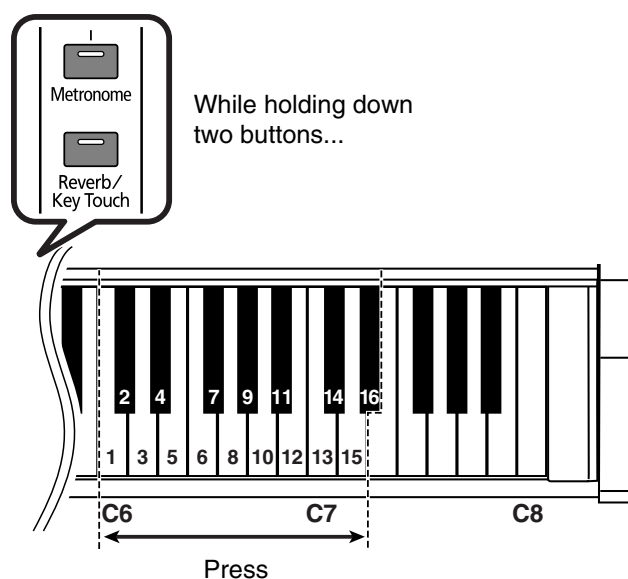

Switching Local Control On and Off

When connecting a MIDI sequencer, set Local Control to "OFF."

As illustrated, information describing what has been played on the keyboard is passed to the internal sound generator over two different routes, (1) and (2). As a result, you hear overlapping or intermittent sounds. To prevent this from happening, route (1) must be severed, by setting the unit to what is known as "Local Off."

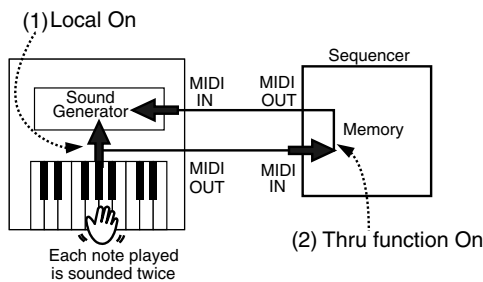

Local Control ON: The keyboard and the internal sound generator are in a linked state.

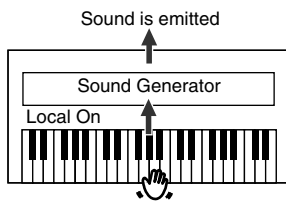

Local Control OFF: The keyboard and the internal sound generator are in an unlinked state. No sound will be produced by the keyboard when it is played.

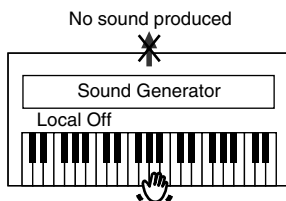

→ When a Roland MT series instrument is connected, it is not necessary to make the Local Off setting. MT units transmit Local Off messages when their power is switched on. If you turn on the power in the order of the HP101 → MT series, Local Off will be set automatically.

Local On is set when the power is switched on.

1. While holding down the [Metronome] and [Reverb/Key Touch] buttons, the "C8" note to turn the setting On, or press the "B7" note to turn the setting Off.

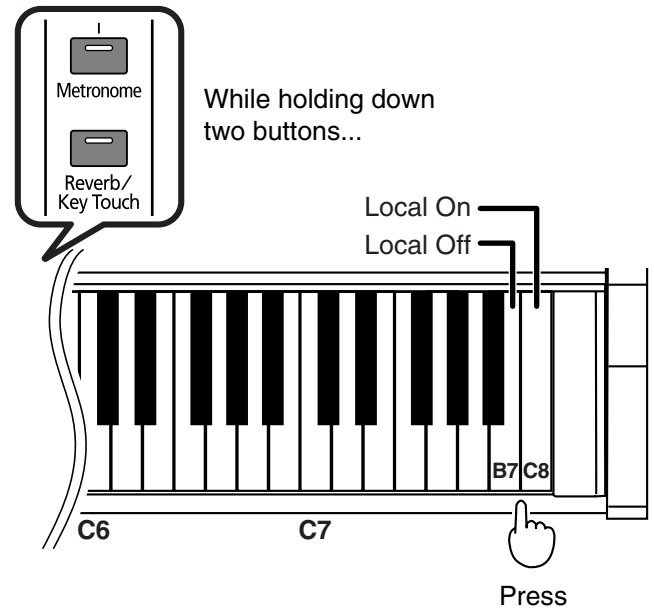

Tone List

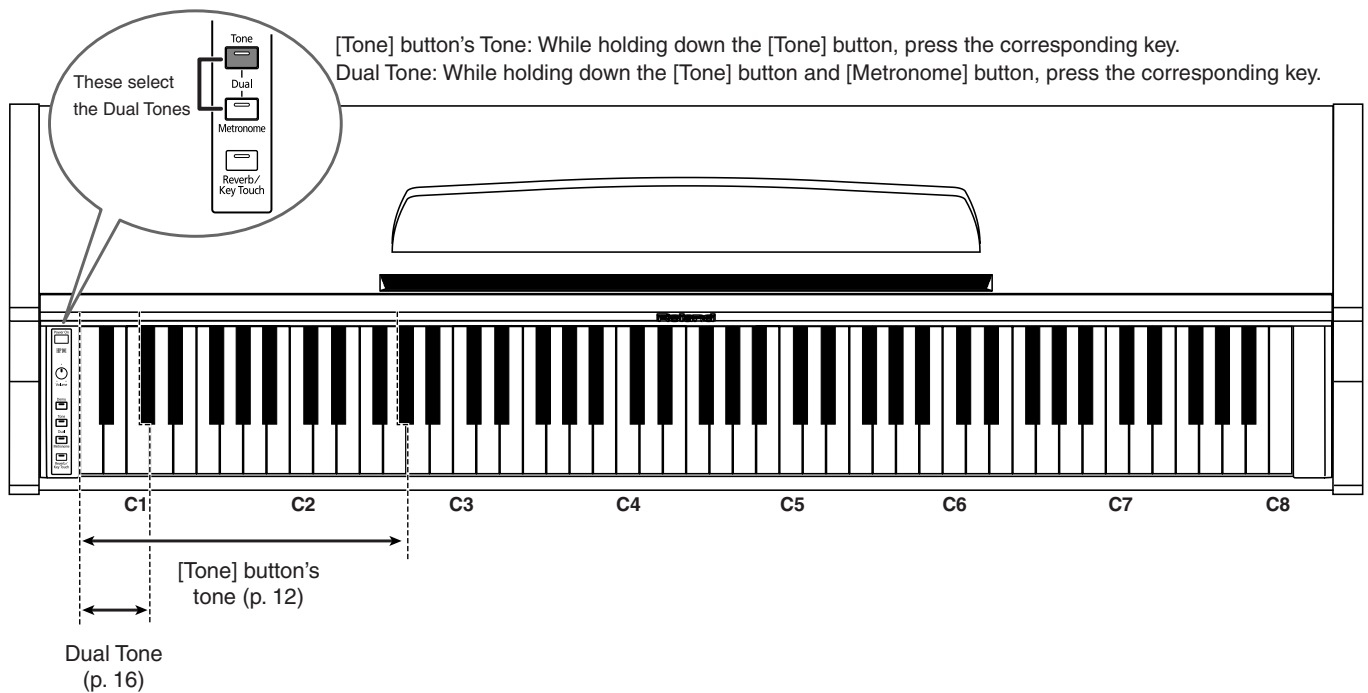

While holding down the [Tone] button, press the corresponding key.

Key Pressed	Tone Number	Tone
A0	1	Grand Piano
B0	2	Mellow Piano
C1	3	Electric Piano1
D1	4	Electric Piano2
E1	5	Vibraphone
F1	6	Harpsichord
G1	7	Coupled Harpsichord
A1	8	Church Organ 1
B1	9	Organ Flute
C2	10	Rotary Organ
D2	11	Church Organ 2
E2	12	Slow Strings
F2	13	Strings
G2	14	Choir

Dual Tone

While holding down the [Tone] button and [Metronome] button, press the corresponding key.

Key Pressed	Tone
A0	Slow Strings
B0	Strings
C1	Choir

Easy Operation List

Metronome Settings

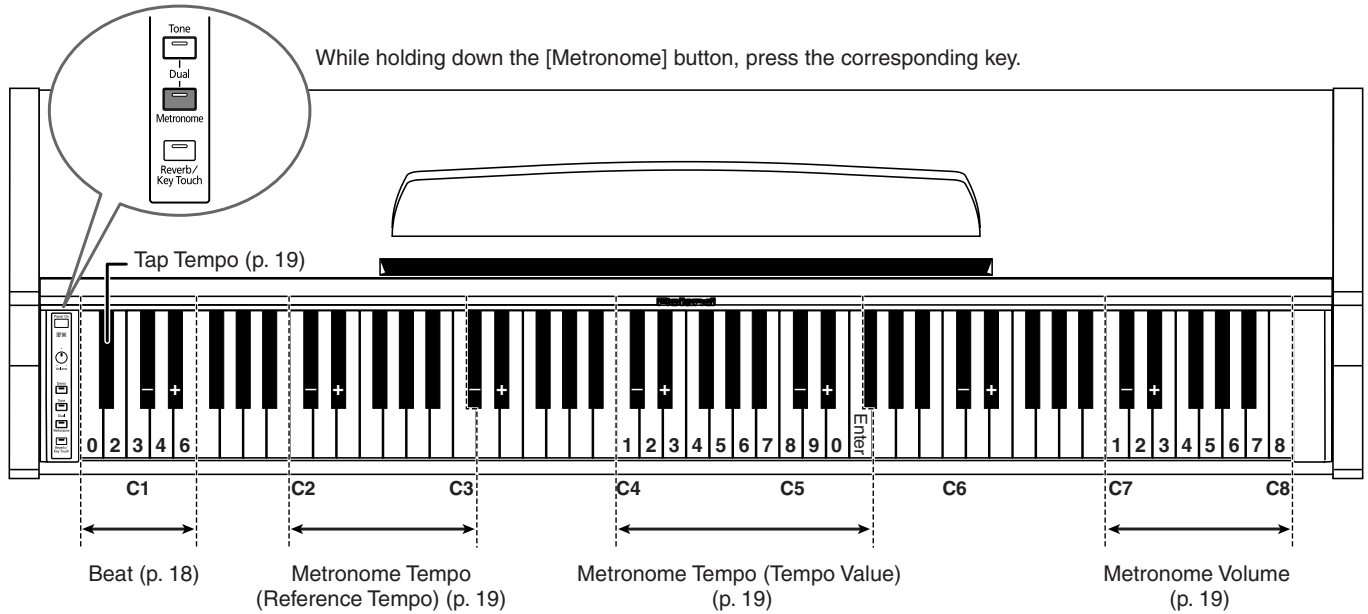

Other Settings

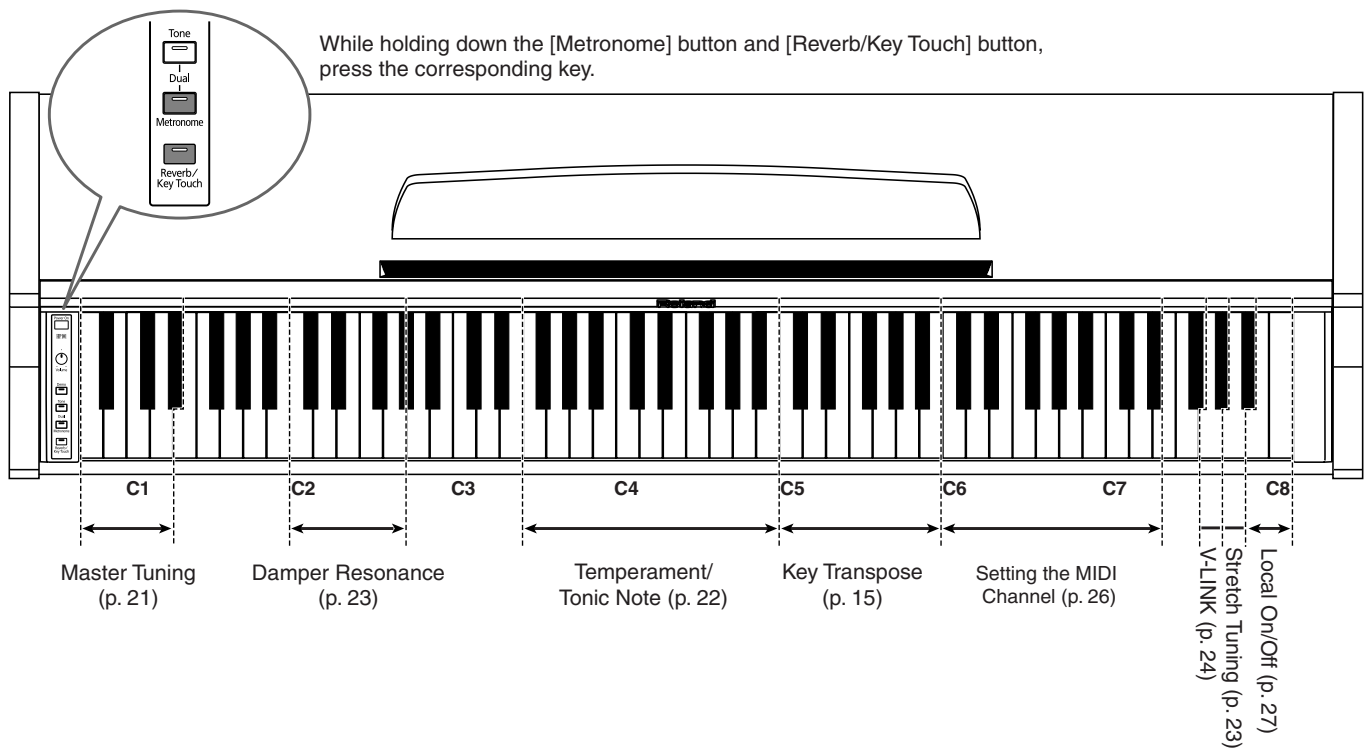

Internal Song List

Song No.	Key	Song Name	Composer	Copyright
1	A0	1ère Arabesque	C. Debussy	© 1995 Roland Corporation
2	B♭0	Late Night Chopin	F. Chopin/ Arranged by John Maul	© 2002 Roland Corporation
3	B0	Sonate für Klavier No. 15	W. A. Mozart	© 1996 Roland Corporation
4	C1	Fly Free	John Maul	© 1998 Roland Corporation
5	C#1	Liebesträume III	F. Liszt	© 2001 Roland Corporation
6	D1	Étude, op.10-3	F. Chopin	© 2001 Roland Corporation
7	D#1	Je te veux	E. Satie	© 1997 Roland Corporation
8	E1	Valse, op.64-1	F. Chopin	© 2001 Roland Corporation
9	F1	Golliwog's Cake walk	C. Debussy	© 1995 Roland Corporation
10	F#1	Fantaisie-Impromptu	F. Chopin	© 2001 Roland Corporation
11	G1	An der schönen, blauen Donau	J. Strauss (II)	© 1996 Roland Corporation
12	G#1	Auf Flügeln des Gesanges	F. Mendelsshon	© 1996 Roland Corporation
13	A1	Mazurka No.5	F. Chopin	© 1995 Roland Corporation
14	B♭1	1ère Gymnopédie	E. Satie	© 1997 Roland Corporation
15	B1	Étude, op.25-1	F. Chopin	© 1995 Roland Corporation
16	C2	Clair de Lune	C. Debussy	© 1998 Roland Corporation
17	C#2	Étude, op.10-5	F. Chopin	© 2001 Roland Corporation
18	D2	Doctor Gradus ad Parnassum	C. Debussy	© 1995 Roland Corporation
19	D#2	Grande Valse Brillante	F. Chopin	© 1995 Roland Corporation
20	E2	La prière d'une Vierge	T. Badarzewska	© 1996 Roland Corporation
21	F2	Course en Troïka	P. Tchaikovsky	© 1996 Roland Corporation
22	F#2	To The Spring	E. Grieg	© 1996 Roland Corporation
23	G2	Valse, op.64-2	F. Chopin	© 1996 Roland Corporation
24	G#2	Radetzky Marsch	J. Strauss (I)	© 1996 Roland Corporation
25	A2	Träumerei	R. Schumann	© 1996 Roland Corporation
26	B♭2	Moments Musicaux III	F. Schubert	© 1996 Roland Corporation
27	B2	Prélude, op.28-15	F. Chopin	© 1996 Roland Corporation
28	C3	The harmonious blacksmith	G. Handel	© 1996 Roland Corporation
29	C#3	Ungarische Tänze V	J. Brähms	© 1996 Roland Corporation
30	D3	Türkischer Marsch (Beethoven)	L. v. Beethoven	© 1996 Roland Corporation
31	D#3	Nocturne No.2	F. Chopin	© 1996 Roland Corporation
32	E3	Frühlingslied	F. Mendelsshon	© 1996 Roland Corporation
33	F3	Präludium	J. S. Bach	© 1996 Roland Corporation
34	F#3	Jägerlied	F. Mendelsshon	© 1996 Roland Corporation
35	G3	Menuet Antique	M. Ravel	© 1996 Roland Corporation
36	G#3	Für Elise	L. v. Beethoven	© 1996 Roland Corporation
37	A3	Türkischer Marsch (Mozart)	W. A. Mozart	© 1996 Roland Corporation
38	B♭3	Ständchen	F. Schubert	© 1996 Roland Corporation
39	B3	Humoreske	A. Dvořák	© 1996 Roland Corporation

Song No.	Key	Song Name	Composer	Copyright
40	C4	Blumenlied	G. Lange	© 1996 Roland Corporation
41	C#4	Alpenglöckchen	T. Oesten	© 1996 Roland Corporation
42	D4	Menuett G dur (Beethoven)	L. v. Beethoven	© 1996 Roland Corporation
43	D#4	Venezianisches Gondellied	F. Mendelsshon	© 1996 Roland Corporation
44	E4	Alpenabendröte	T. Oesten	© 1996 Roland Corporation
45	F4	Farewell to the Piano	L. v. Beethoven	© 1996 Roland Corporation
46	F#4	Brautchor	R. Wagner	© 1996 Roland Corporation
47	G4	Battle of Waterloo	W. Anderson	© 1996 Roland Corporation
48	G#4	Wiener Marsch	C. Czerny	© 1996 Roland Corporation
49	A4	Le Coucou	L. C. Daquin	© 1996 Roland Corporation
50	B♭4	Menuett G dur (Bach)	J. S. Bach	© 1992 Roland Corporation
51	B4	Spinnerlied	A. Ellmenreich	© 1996 Roland Corporation
52	C5	Gavotte	F. Gossec	© 1996 Roland Corporation
53	C#5	Heidenröslein	G. Lange	© 1996 Roland Corporation
54	D5	Zigeuner Tanz	H. Lichner	© 1996 Roland Corporation
55	D#5	La Cinquantaine	G. Marie	© 1996 Roland Corporation
56	E5	Csikos Post	H. Necke	© 1996 Roland Corporation
57	F5	Dolly's Dreaming Awakening	T. Oesten	© 1996 Roland Corporation
58	F#5	La Violette	L. Streabbog	© 1996 Roland Corporation
59	G5	Fröhlicher Landmann	R. Schumann	© 1996 Roland Corporation
60	G#5	Sonatine op.36-1 (Clementi)	M. Clementi	© 1996 Roland Corporation
61	A5	Sonatine op.20-1 (Kuhlau)	F. Kuhlau	© 1996 Roland Corporation
62	B♭5	Sonatine No.5 (Beethoven)	L. v. Beethoven	© 1996 Roland Corporation
63	B5	Hungarian Rag: Hungarian Dance No. 5 Ragtime Arrangement For Solo Piano	J. Brahms/ Arranged by John Maul	© 1996 Roland Corporation
64	C6	Paganooogie Variation: Jazz Variation Based on "Caprice No. 24 in A Minor"	N. Paganini/ Arranged by John Maul	© 1998 Roland Corporation
65	C#6	L'éveil del l'amour	Masashi & Kazuko Hirashita	© 2000 Roland Corporation

* All rights reserved. Unauthorized use of this material for purposes other than private, personal enjoyment is a violation of applicable laws.

Profile

John Maul

John Maul is a musician, composer and arranger having graduated from the Royal Academy of Music in London. John's work encompasses studio recordings and live performances including work with top UK Jazz artists.

His writing credits include commercial music for BBC radio and television, as well as scoring jazz and classical works.

Having been a product specialist for Roland U.K., John is now actively involved in music software composing/programming for both Roland Japan and various music publishers. Quite recently his "Musical Picture Book," a volume of original piano music encompassing all standards of musical ability, which included the piano and orchestral accompaniment data in SMF format, was published and printed.

Troubleshooting

If you think there's a problem, read this first.

Case	Cause/Remedy
The power doesn't come on	Is the power cord connected and plugged in correctly? (p. 8)
The button doesn't work	Is the panel locked? (p. 24) Turn the power off, then back on.
No sound is heard	Is the volume level of the HP101 turned all the way down? (p. 9)
	Are headphones plugged in? (p. 9) Has a plug remained connected to the Phones jack? Plugging headphones or other plugs into the headphone jack stops sounds from playing through the speakers.
	Is Local Off selected? When Local Control is set to OFF, no sound is produced by playing the keyboard. Set Local Control to "On" (p. 27).
	Is V-LINK switched on? While V-LINK is switched on, no sound is produced when you press any of the twelve keys at the left end of the keyboard (p. 24).
No sound is heard (when a MIDI instrument is connected)	Have all devices been switched on?
	Are the MIDI cables connected correctly?
	Does the MIDI channel match the connected instrument? (p. 26)
Sounds are heard twice (doubled) when the keyboard is played	Is the HP101 in Dual play? (p. 16)
	When the HP101 is connected to an external sequencer, set it to the Local OFF mode (p. 27). Alternatively, the sequencer could be set so its MIDI Thru feature is OFF.
Tone doesn't change	Is the panel locked? (p. 24) Turn the power off, then back on.
Not all played notes are sounded	The maximum number of notes that the HP101 can play simultaneously is 64. Frequent use of the damper pedal when playing along with a song may result in performance data with too many notes, causing some notes to drop out.
The tuning or pitch of the keyboard or song is off	Have you set Transpose? (p. 15)
	Are the settings for the "Temperament" and "Stretch Tuning" correct? (p. 22)
	Is the setting for the "Master Tuning" correct? (p. 21)
Depressing a pedal has no effect, or the pedal effect doesn't stop	Is the pedal connected correctly? Make sure the pedal cord is securely connected to the pedal jack on the bottom of the unit, at the rear (p. 8).
The pedal rattles	Adjust the adjuster underneath the pedal so that the adjuster presses firmly against the floor surface (p. 10).

Case	Cause/Remedy
In the upper range, the sound changes abruptly beyond a certain key	On an acoustic piano, notes in the upper one and a half octaves of the keyboard continue to sound until they decay naturally, regardless of the damper pedal. There is a difference in the timbre as well. Roland pianos faithfully simulate such characteristics of the acoustic piano. On the HP101, the range that is unaffected by the damper pedal will change depending on the Key Transpose setting.
A High-pitched whine is produced	When listening through headphones: Some of the more flamboyant and effervescent piano tones feature an ample high-end component, which may make the sound appear to have metallic reverberation added. Since this reverberation becomes particularly audible when supplemented by heavy reverb, you may be able to diminish the problem by reducing the amount of reverb applied to the sound.
	When listening through speakers: Here, a different cause (such as resonance produced by the HP101) would be suspect. Consult your Roland dealer or nearest Roland Service Center.
The bass range sounds odd, or there is a vibrating resonance	When listening through speakers: Playing at loud volumes may cause instruments near the HP101 to resonate. Resonation can also occur with fluorescent light tubes, glass doors, and other objects. In particular, this problem occurs more easily when the bass component is increased, and when the sound is played at higher volumes. Use the following measures to suppress such resonance.
	<ul style="list-style-type: none"> • Place speakers so they are 10–15 cm from walls and other surfaces. • Reduce the volume. • Move the speakers away from any resonating objects.
	When listening through headphones: Here, a different cause would be suspect. Consult your Roland dealer or nearest Roland Service Center.
The volume level of the instrument connected to Input jacks is too low	Could you be using a connection cable that contains a resistor? Use a connection cable that does not contain a resistor.

MIDI Implementation Chart

Function...	Transmitted	Recognized	Remarks
Basic Channel Default Changed	1 1-16	1 1-16	
Mode Default Messages Altered	Mode 3 x *****	Mode 3 x	
Note Number : True Voice	15-113 *****	0-127 15-113	
Velocity Note ON Note OFF	O x 8n v=64	O x	
After Touch Key's Ch's	x x	x x	
Pitch Bend	x	x	
Control Change 6, 38 7 11 64 66 67 91 100, 101	O x x O O O O O O	O O O O O O O O	Data entry Volume Expression Hold 1 Sostenuto Soft Effect 1 (Reverb) RPN LSB, MSB
Prog Change : True Number	O (0...57) *****	O (0-127) 0...57	
System Exclusive	O	O	
System Common : Song Pos : Song Sel : Tune	x x x	x x x	
System Real Time : Clock : Commands	x x	x x	
Aux Message : All sound off : Reset all controllers : Local Control : All Notes OFF : Active Sense : Reset	x x x x O x	x O O O (123-127) O x	
Notes			

Mode 1 : OMNI ON, POLY Mode 2 : OMNI ON, MONO
Mode 3 : OMNI OFF, POLY Mode 4 : OMNI OFF, MONO

O : Yes
X : No

Main Specifications

Keyboard	
Keyboard	88 keys (Compact Progressive Hammer Action Keyboard)
Touch Sensitivity	Touch: Light, Medium, Heavy, Fixed
Keyboard Modes	Whole, Dual (volume balance adjustable)
Sound Generator	
Max. Polyphony	64 voices
Tones	14 tones
Temperament	7 types, selectable tonic
Stretched Tuning	2 types
Master Tuning	415.3 Hz–466.2 Hz (adjustable in increments of 0.1 Hz)
Transpose	Key Transpose (-6–+5 in semitones)
Effects	Reverb (8 levels), Chorus (for E. Piano only), Damper Resonance (8 levels)
Metronome	
Beat	0/4, 2/4, 3/4, 4/4, 6/4
Volume	8 levels
Tempo	Quarter note = 20–250
Preset Songs	65 songs
Others	
Rated Power Output	20 W x 2
Speakers	12 cm x 2
Display	Beat LED
Control	Volume
Pedals	Damper, Soft, Sostenuto
Other Functions	Panel Lock, Twin Piano Mode
Connectors	Output jacks (L/Mono, R), Input jacks (L/Mono, R), Headphones jack x 2 (Stereo), MIDI connectors (In, Out)
Power Supply	AC 117 V / AC 230 V / AC 240 V
Power Consumption	48 W
Dimensions (including piano stand)	1,388 (W) x 397 (D) x 810 (H) mm 54-11/16 (W) x 15-11/16 (D) x 31-15/16 (H) inches
	1,388 (W) x 397 (D) x 1,000 (H) mm (including music rest) 54-11/16 (W) x 15-11/16 (D) x 39-3/8 (H) inches (including music rest)
Weights (including piano stand)	42 kg / 93 lbs
Accessories	Owner's manual, Power Cord, Headphones Hook, Music Rest, Music Rest's attachment screws

* In the interest of product improvement, the specifications and/or appearance of this unit are subject to change without prior notice.

Index

Numerics

440.0 Hz	21
442.0 Hz	21

A

AC Inlet	8
Adjuster	10
Audio Equipment	25

B

Beat	18
------------	----

C

Computer	25
----------------	----

D

Damper Pedal	10
Resonance	23
Damper Resonance	10, 23
Dual Balance	16
Dual Play	16

E

Effects (Reverb)	13
------------------------	----

H

Headphone Hook	9
Headphones	9

I

Internal Song	11
---------------------	----

K

Key Touch	14
-----------------	----

L

Lid	8
Local Control	27

M

Master Tuning	21
Metronome	17
Volume	19
MIDI	26
MIDI Channel	26
MIDI Devices	26
Music Rest	8

P

Panel Lock	24
Pedal	10
Pedal Cable	8
Pedal Jack	8
Phones Jack	9
Play	
Selecting a Song	11
Power	9
Power Cord	8
Power Indicator	9
[Power On] Switch	9

R

Reverb	13
Depth	13

S

Soft Pedal	10
Sostenuto Pedal	10
Standard Pitch	21
Stretch Tuning	23

T

Tap Tempo	19
Temperament	22
Tempo	18
Tone	12
[Tone] Button	12
Transpose	15
Tuning Curve	23
Twin Piano Mode	20

V

V-LINK	24
Volume	9
Metronome	19
[Volume] Knob	9

MEMO

MEMO

Information

When you need repair service, call your nearest Roland Service Center or authorized Roland distributor in your country as shown below.

AFRICA

EGYPT

Al Fanny Trading Office
9, EBN Hagar A1 Askalany Street,
ARD El Golf, Heliopolis,
Cairo 11341, EGYPT
TEL: 20-2-417-1828

REUNION

Maison FO - YAM Marcel
25 Rue Jules Hermann,
Chaudron - BP79 97 491
Ste Clotilde Cedex,
REUNION ISLAND
TEL: (0262) 218-429

SOUTH AFRICA

**That Other Music Shop
(PTY) Ltd.**
11 Melle St., Braamfontein,
Johannesburg, SOUTH AFRICA

P.O.Box 32918, Braamfontein 2017
Johannesburg, SOUTH AFRICA
TEL: (011) 403 4105

Paul Bothner (PTY) Ltd.
17 Werdmuller Centre,
Main Road, Claremont 7708
SOUTH AFRICA

P.O.Box 23032, Claremont 7735,
SOUTH AFRICA
TEL: (021) 674 4030

ASIA

CHINA

**Roland Shanghai Electronics
Co.,Ltd.**
5F, No.150 Pingliang Road
Shanghai 200090, CHINA
TEL: (021) 5580-0800

**Roland Shanghai Electronics
Co.,Ltd.
(BEIJING OFFICE)**
10F, No.18 Anhuaxili
Chaoyang District, Beijing 100011
CHINA
TEL: (010) 6426-5050

**Roland Shanghai Electronics
Co.,Ltd.
(GUANGZHOU OFFICE)**
2/F., No.30 Si You Nan Er Jie Yi
Xiang, Wu Yang Xin Cheng,
Guangzhou 510600, CHINA
Tel: (020) 8736-0428

HONG KONG

**Tom Lee Music Co., Ltd.
Service Division**
22-32 Pun Shan Street, Tsuen
Wan, New Territories,
HONG KONG
TEL: 2415 0911

Parsons Music Ltd.
8th Floor, Railway Plaza, 39
Chatham Road South, T.S.T.,
Kowloon, HONG KONG
TEL: 2333 1863

INDIA

Rivera Digitec (India) Pvt. Ltd.
409, Nirman Kendra Mahalaxmi
Flats Compound Off. Dr. Edwin
Moses Road, Mumbai-400011,
INDIA
TEL: (022) 2493 9051

INDONESIA

PT Citra IntiRama
Jl. Cideng Timur No. 15J-150
Jakarta Pusat
INDONESIA
TEL: (021) 6324170

KOREA

Cosmos Corporation
1461-9, Seocho-Dong,
Seocho Ku, Seoul, KOREA
TEL: (02) 3486-8855

MALAYSIA

BENTLEY MUSIC SDN BHD
140 & 142, Jalan Bukit Bintang
55100 Kuala Lumpur, MALAYSIA
TEL: (03) 2144-3333

PHILIPPINES

G.A. Yupangco & Co. Inc.
339 Gil J. Puyat Avenue
Makati, Metro Manila 1200,
PHILIPPINES
TEL: (02) 899 9801

SINGAPORE

Swee Lee Company
150 Sims Drive,
SINGAPORE 387381
TEL: 6846-3676

CRISTOFORI MUSIC PTE LTD

Blok 3014, Bedok Industrial Park E,
#02-2148, SINGAPORE 489980
TEL: 6243-9555

TAIWAN

**ROLAND TAIWAN
ENTERPRISE CO., LTD.**
Room 5, 9fl. No. 112 Chung Shan
N.Road Sec.2, Taipei, TAIWAN,
R.O.C.
TEL: (02) 2561 3339

THAILAND

Theera Music Co., Ltd.
330 Verg NakornKasem, Soi 2,
Bangkok 10100, THAILAND
TEL: (02) 2248821

VIETNAM

Saigon Music
Suite DP-8
40 Ba Huyen Thanh Quan Street
Hochiminh City, VIETNAM
Tel: (08) 930-1969

AUSTRALIA/ NEW ZEALAND

AUSTRALIA

**Roland Corporation
Australia Pty., Ltd.**
38 Campbell Avenue
Dee Why West, NSW 2099
AUSTRALIA
TEL: (02) 9982 8266

NEW ZEALAND

Roland Corporation Ltd.
32 Shaddock Street, Mount Eden,
Auckland, NEW ZEALAND
TEL: (09) 3098 715

CENTRAL/LATIN AMERICA

ARGENTINA

Instrumentos Musicales S.A.
Av.Santa Fe 2055
(1123) Buenos Aires
ARGENTINA
TEL: (011) 4508-2700

BRAZIL

Roland Brasil Ltda
Rua San Jose, 780 Sala B
Parque Industrial San Jose
Cotia - Sao Paulo - SP, BRAZIL
TEL: (011) 4615 5666

COSTA RICA

**JUAN BANSBACH
Instrumentos Musicales**
Ave.1. Calle 11, Apartado 10237,
San Jose, COSTA RICA
TEL: 258-0211

CHILE

Comercial Fancy II S.A.
Rut.: 96.919.420-1
Nataníel Cox #739, 4th Floor
Santiago - Centro, CHILE
TEL: (02) 688-9540

EL SALVADOR

OMNI MUSIC
75 Avenida Norte y Final
Alameda Juan Pablo II,
Edificio No.4010 San Salvador,
EL SALVADOR
TEL: 262-0788

MEXICO

Casa Veerkamp, s.a. de c.v.
Av. Toluca No. 323, Col. Olivar
de los Padres 01780 Mexico D.F.
MEXICO
TEL: (55) 5668-6699

PANAMA

SUPRO MUNDIAL, S.A.
Boulevard Andrews, Albrook,
Panama City, REP. DE PANAMA
TEL: 315-0101

PARAGUAY

**Distribuidora De
Instrumentos Musicales**
J.E. Olear y ESQ. Manduvira
Asuncion PARAGUAY
TEL: (021) 492-124

URUGUAY

Todo Musica S.A.
Francisco Acuna de Figueroa 1771
C.P.: 11.800
Montevideo, URUGUAY
TEL: (02) 924-2335

VENEZUELA

Musicaland Digital C.A.
Av. Francisco de Miranda,
Centro Parque de Cristal, Nivel
C2 Local 20 Caracas
VENEZUELA
TEL: (212) 285-8586

EUROPE

AUSTRIA

**Roland Elektronische
Musikinstrumente HmbH.
Austrian Office**
Eduard-Bodem-Gasse 8,
A-6020 Innsbruck, AUSTRIA
TEL: (0512) 26 44 260

BELGIUM/HOLLAND/ LUXEMBOURG

Roland Benelux N. V.
Houtstraat 3, B-2260, Oevel
(Westerlo) BELGIUM
TEL: (014) 575811

CZECH REP.

K-AUDIO
Kardasovska 626.
CZ-198 00 Praha 9,
CZECH REP.
TEL: (2) 666 10529

DENMARK

Roland Scandinavia A/S
Nordhavnsvej 7, Postbox 880,
DK-2100 Copenhagen
DENMARK
TEL: 3916 6200

FRANCE

Roland France SA
4, Rue Paul Henri SPAAK,
Parc de l'Esplanade, F 77 462 St.
Thibault, Lagny Cedex FRANCE
TEL: 01 600 73 500

FINLAND

**Roland Scandinavia As,
Filial Finland**
Elannontie 5
FIN-01510 Vantaa, FINLAND
TEL: (09) 68 24 020

GERMANY

**Roland Elektronische
Musikinstrumente HmbH.**
Oststrasse 96, 22844 Norderstedt,
GERMANY
TEL: (040) 52 60090

GREECE

**STOLLAS S.A.
Music Sound Light**
155, New National Road
Patras 26442, GREECE
TEL: 2610 435400

HUNGARY

Roland East Europe Ltd.
Warehouse Area 'DEPO' Pf.83
H-2046 Torokbalint, HUNGARY
TEL: (23) 511011

IRELAND

Roland Ireland
G2 Calmount Park, Calmount
Avenue, Dublin 12
Republic of IRELAND
TEL: (01) 4294444

ITALY

Roland Italy S. p. A.
Viale delle Industrie 8,
20020 Arese, Milano, ITALY
TEL: (02) 937-78300

NORWAY

**Roland Scandinavia Avd.
Kontor Norge**
Lilleakerveien 2 Postboks 95
Lilleaker N-0216 Oslo
NORWAY
TEL: 2273 0074

POLAND

MX MUSIC SP.Z.O.O.
UL. Gibraltarska 4.
PL-03664 Warszawa POLAND
TEL: (022) 679 44 19

PORTUGAL

**Tecnologias Musica e Audio,
Roland Portugal, S.A.**
Cais Das Pedras, 8/9-1 Dto
4050-465 PORTO
PORTUGAL
TEL: (022) 608 00 60

ROMANIA

FBS LINES
Piata Libertatii 1,
535500 Gheorgheni, ROMANIA
TEL: (266) 364 609

RUSSIA

MuTek
3-Bogatyrskaya Str. 1.k.1
107 564 Moscow, RUSSIA
TEL: (095) 169 5043

SPAIN

**Roland Electronics
de España, S. A.**
Calle Bolivia 239, 08020
Barcelona, SPAIN
TEL: (93) 308 1000

SWEDEN

**Roland Scandinavia A/S
SWEDISH SALES OFFICE**
Danvik Center 28, 2 tr.
S-131 30 Nacka SWEDEN
TEL: (0)8 702 00 20

SWITZERLAND

Roland (Switzerland) AG
Landstrasse 5, Postfach,
CH-4452 Itingen,
SWITZERLAND
TEL: (061) 927-8383

UKRAINE

TIC-TAC
Mira Str. 19/108
P.O. Box 180
295400 Munkachevo, UKRAINE
TEL: (03131) 414-40

UNITED KINGDOM

Roland (U.K.) Ltd.
Atlantic Close, Swansea
Enterprise Park, SWANSEA
SA7 9FJ,
UNITED KINGDOM
TEL: (01792) 702701

MIDDLE EAST

BAHRAIN

Moon Stores
No.16, Bab Al Bahrain Avenue,
P.O.Box 247, Manama 304,
State of BAHRAIN
TEL: 211 005

CYPRUS

Radex Sound Equipment Ltd.
17, Diagorou Street, Nicosia,
CYPRUS
TEL: (022) 66-9426

IRAN

MOCO, INC.
No.41 Nike St., Dr.Shariyati Ave.,
Roberoye Cerah Mirdamad
Tehran, IRAN
TEL: (021) 285-4169

ISRAEL

**Halilit P. Greenspoon &
Sons Ltd.**
8 Retzif Ha aliya Hashnya St.
Tel-Aviv-Yafo ISRAEL
TEL: (03) 6823666

JORDAN

AMMAN Trading Agency
245 Prince Mohammad St.,
Amman 1118, JORDAN
TEL: (06) 464-1200

KUWAIT

Easa Husain Al Yousefi Est.
Abdullah Salem Street,
Safat, KUWAIT
TEL: 243-6399

LEBANON

Chahine S.A.L.
Gerge Zeidan St., Chahine Bldg.,
Achrafieh, P.O.Box: 16-5857
Beirut, LEBANON
TEL: (01) 20-1441

QATAR

**Al Emadi Co. (Badie Studio
& Stores)**
P.O. Box 62, Doha, QATAR
TEL: 4423-554

SAUDI ARABIA

**aDawlah Universal
Electronics APL**
Corniche Road, Aldossary Bldg.,
1st Floor, Alkhobar,
SAUDI ARABIA

P.O.Box 2154, Alkhobar 31952
SAUDI ARABIA
TEL: (03) 898 2081

SYRIA

**Technical Light & Sound
Center**
Rawda, Abdul Qader Jazairi St.
Bldg. No. 21, P.O.Box 13520,
Damascus, SYRIA
TEL: (011) 223-5384

TURKEY

**Ant Muzik Aletleri Ithalat
Ve Ihracat Ltd Sti**
Siraselviler Caddesi Siraselviler
Pasaji No:74/20
Taksim - Istanbul, TURKEY
TEL: (0212) 2449624

U.A.E.

**Zak Electronics & Musical
Instruments Co. L.L.C.**
Zabeel Road, Al Sherooq Bldg.,
No. 14, Grand Floor, Dubai, U.A.E.
TEL: (04) 3360715

NORTH AMERICA

CANADA

**Roland Canada Music Ltd.
(Head Office)**
5480 Parkwood Way Richmond
B. C., V6V 2M4 CANADA
TEL: (604) 270 6626

**Roland Canada Music Ltd.
(Toronto Office)**
170 Admiral Boulevard
Mississauga On L5T 2N6
CANADA
TEL: (905) 362 9707

U. S. A.

Roland Corporation U.S.
5100 S. Eastern Avenue
Los Angeles, CA 90040-2938,
U. S. A.
TEL: (323) 890 3700

As of May 1, 2004 (Roland)

For EU Countries



This product complies with the requirements of European Directives EMC 89/336/EEC and LVD 73/23/EEC.

For the USA

FEDERAL COMMUNICATIONS COMMISSION RADIO FREQUENCY INTERFERENCE STATEMENT

This equipment has been tested and found to comply with the limits for a Class B digital device, pursuant to Part 15 of the FCC Rules. These limits are designed to provide reasonable protection against harmful interference in a residential installation. This equipment generates, uses, and can radiate radio frequency energy and, if not installed and used in accordance with the instructions, may cause harmful interference to radio communications. However, there is no guarantee that interference will not occur in a particular installation. If this equipment does cause harmful interference to radio or television reception, which can be determined by turning the equipment off and on, the user is encouraged to try to correct the interference by one or more of the following measures:

- Reorient or relocate the receiving antenna.
- Increase the separation between the equipment and receiver.
- Connect the equipment into an outlet on a circuit different from that to which the receiver is connected.
- Consult the dealer or an experienced radio/TV technician for help.

This device complies with Part 15 of the FCC Rules. Operation is subject to the following two conditions:

- (1) This device may not cause harmful interference, and
- (2) This device must accept any interference received, including interference that may cause undesired operation.

Unauthorized changes or modification to this system can void the users authority to operate this equipment.
This equipment requires shielded interface cables in order to meet FCC class B Limit.

For Canada

NOTICE

This Class B digital apparatus meets all requirements of the Canadian Interference-Causing Equipment Regulations.

AVIS

Cet appareil numérique de la classe B respecte toutes les exigences du Règlement sur le matériel brouilleur du Canada.

This owner's manual is printed on recycled paper.

Free Manuals Download Website

<http://myh66.com>

<http://usermanuals.us>

<http://www.somanuals.com>

<http://www.4manuals.cc>

<http://www.manual-lib.com>

<http://www.404manual.com>

<http://www.luxmanual.com>

<http://aubethermostatmanual.com>

Golf course search by state

<http://golfingnear.com>

Email search by domain

<http://emailbydomain.com>

Auto manuals search

<http://auto.somanuals.com>

TV manuals search

<http://tv.somanuals.com>